



KALIP ve İŞ PARÇASI BAĞLAMA SİSTEMLERİ  
*Mold and Workpiece Clamping Systems*

## HIZLI KALIP DEĞİŞTİRME SİSTEMİ QUICK MOLD CHANGE SYSTEM

Zamanı  
Üretime Dönüştürün..!



Use Time Wisely  
for Production..!

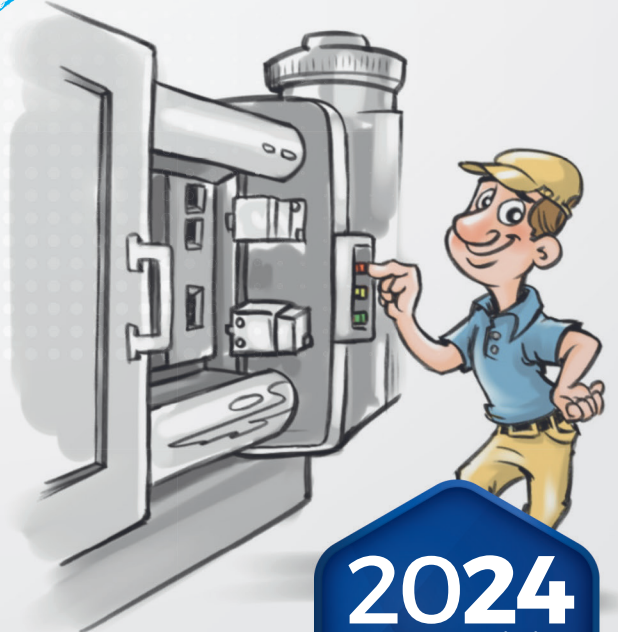
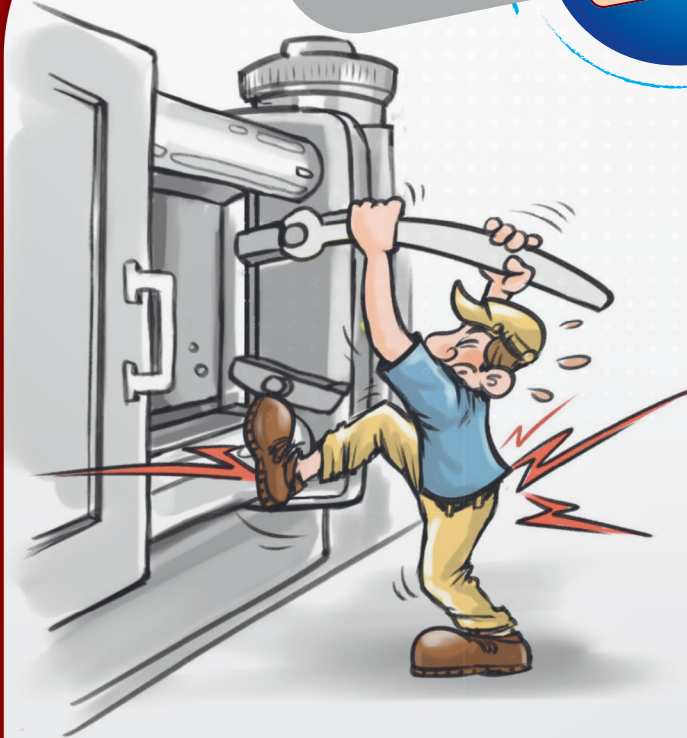

[www.er-el.com.tr](http://www.er-el.com.tr)





## DEĞERLİ MÜŞTERİMİZ;

ER-EL MAKİNA YEDEK PARÇA İMALATI SAN. VE TİC. LTD ŞTİ. olarak 1989 'dan beri kalıp bağlama ve işleme ekipmanlarında bizi güven ve kalitenin simgesi haline getiren ürünler üretmekteyiz. Geçen yıllar içinde mevcut kapasite ve toplam istihdam alanında sürekli artan bir çizgiyle her geçen gün daha sağlam ve emin adımlarla ilerleyen ER-EL; bugün başta Avrupa ülkeleri olmak üzere 45'i aşkın ülkeye ihracat yapmaktadır.

Her biri ayrı değer ve öneme sahip olan müşterilerimizin ihtiyaç ve taleplerine uygun çözümler sunmak amacıyla faaliyet gösteren ARGE bölümümüz ürün çeşitliliğini arttırmaya yönelik çalışmalarını büyük bir özveriyle sürdürmektedir. Katma değerli, kaliteli ve güvenli ürünler üretmek adına yatırımlarını arttırarak verimli, sürdürülebilir bir yol izleyen firmamız; 2004 yılında ISO 9001:2015 Kalite Yönetim Sistemini kurarak var olan kalitesini belgelendirmiştir. Akabinde ISO14001:2015 Çevre Yönetim Sistemi, ISO 45001:2018 İş Sağlığı ve Güvenliği Yönetim Sistemi ve CE sertifikalarına sahip olarak buna uygun üretim yapmaktadır.

Bugün itibari ile Kalıp & İş parçası Bağlama Ekipmanları, İşleme Sistemlerinde 4500'ü aşan hemen teslim stok ürünü çeşitleriyle konusunda lider ve üretici firma olmanın gururunu yaşamaktayız.

Standart üretimlerimiz dışında proje bazlı fişktür imalatımız da mevcuttur. Başta Savunma & Havaçılık Sanayi olmak üzere, Otomotiv, Beyaz Eşya, Ağır Makine ve Silah Sanayi sektörleri gibi Sanayinin güzide firmalarında; iş parçasına özel tasarım yapıp ürettiğimiz mekanik, pnömatrik ve hidrolik fişktür ürünleri kullanılmaktadır. Sistem verimini optimize eden ürün grubumuzla; dünyaca kabul görmüş, alanında geçerliliğe sahip standartlarda üretmeye devam etmekteyiz.

Firmamız 2017 yılında taşındığı yeni fabrikasında; üretim tesisi ve yönetim binası alanında dinamik ve uzman kadrosu ile gerek standart, gerek proje bazlı fişktür çözümleri ile müşteri memnuniyeti için üstün performans ile çalışmaktadır.

Uzun yıllardır ülkemizde ve Yurtdışında kalıp bağlama elemanları üreticisi olarak sektöre hizmet veren MİKSAN Hızlı Bağlama Sistemleri firması satın alınarak ER-EL Kalıp Bağlama ve İşleme Sistemleri firmamız bünyesine katılmıştır. Bir ER-EL markası olan MİKSAN ürünleri; firmamız kalite ve güvencesiyle hizmet vermeye devam edecektir.

Siz değerli müşterilerimize ER-EL'e olan güveninizden dolayı teşekkür eder, aynı istikrar ve güvenle uzun yıllar çalışmayı temenni ederiz.

Saygılarımızla;  
ER-EL Yönetimi

## OUR ESTEEMED CUSTOMER;

*ER-EL MACHINE SPARE PARTS MANUFACTURING INDUSTRY CO.LTD. Since 1989, we have been producing products that make us a symbol of trust and quality in mold clamping and processing equipment. Over the years, ER-EL has progressed more and more confidently with its increasing capacity and total employment. Today, it export to more than 45 countries, mainly European countries.*

*Our R & D department, which operates to provide solutions that meet the needs and demands of our customers, each of which has a distinct value and importance, continues its efforts to increase the product variety with great devotion. Our company follows an efficient, sustainable way by increasing its investments in order to produce value added, quality and safe products; In 2004, it established ISO 9001:2015 Quality Management System and documented its existing quality. The company has ISO14001:2015 Environmental Management System, ISO 45001:2018 Occupational Health and Safety Management System.*

*As of today, we are proud to be the leader and manufacturer company in the field of mold & workpiece clamping equipment and processing systems, over 4500 fast immediate delivery stock products.*

*In addition to our standard production, we also produce project-based special fixture apparatus. Especially in Defense & Aviation Industry, Automotive, White Goods, Heavy Machinery and Weapon Industry sectors such as industry-renowned companies; mechanical, pneumatic and hydraulic fixture products that we design and produce for the workpiece are used. With our product group optimizing system efficiency; we continue to produce world-accepted standards that are valid in the field.*

*Our company moved to the new factory in 2017; with its dynamic and expert staff in the field of production facility and management building, it works with superior performance for customer satisfaction with both standard and project based fixture solutions.*

*MIKSAN Fast Coupling Systems company which has been serving to the sector as a manufacturer of mold fasteners in our country and abroad for many years has been purchased as of and ER-EL Mold Clamping and Processing Systems has joined our company. MIKSAN products which are an ER-EL brand; Our company will continue to serve with quality and assurance.*

*We would like to thank you, our esteemed customers for your trust in ER-EL and hope to work for many years with the same stability and confidence.*

Kind regards;  
ER-EL Directors



# index

<p>Nr. 1010 S. 10</p> 	<p>Nr. 1010 S. 11</p> 	<p>Nr. 1010 S. 12</p> 	<p>Nr. 1015 S. 13</p> 
<p>Nr. 1015 S. 14</p> <p><b>NEW</b></p> 	<p>Nr. 1015 S. 15</p> 	<p>Nr. 1015 S. 15</p> 	<p>Nr. 1015 S. 16</p> 
<p>Nr. 1015 S. 17</p> 	<p>Nr. 1020 S. 18</p> 	<p>Nr. 1020 S. 19 S. 21 S. 23 S. 25 S. 27 S. 28</p> 	<p>Nr. 1022 S. 20 S. 22 S. 24 S. 26</p> 
<p>Nr. 1023 S. 29 S. 30</p> <p><b>NEW</b></p> 	<p>Nr. 1022 S. 31</p> 	<p>Nr. 1022 S. 31</p> 	<p>Nr. 1024 S. 33</p> 
<p>Nr. 1024 S. 34</p> 	<p>Nr. 1025 S. 36</p> 	<p>Nr. 1030 S. 37</p> 	<p>Nr. 1033 S. 38</p> 
<p>Nr. 1037 S. 39</p> 	<p>Nr. 1038 S. 40</p> 	<p>Nr. 1040 S. 41</p> 	<p>Nr. 1041 S. 41</p> 
<p>Nr. 1041 S. 42</p> 	<p>Nr. 1040 S. 42</p> 	<p>Nr. 1040 S. 42</p> 	

# HIZLI KALIP DEĞİŞTİRME SİSTEMİ

QUICK MOLD CHANGE SYSTEM

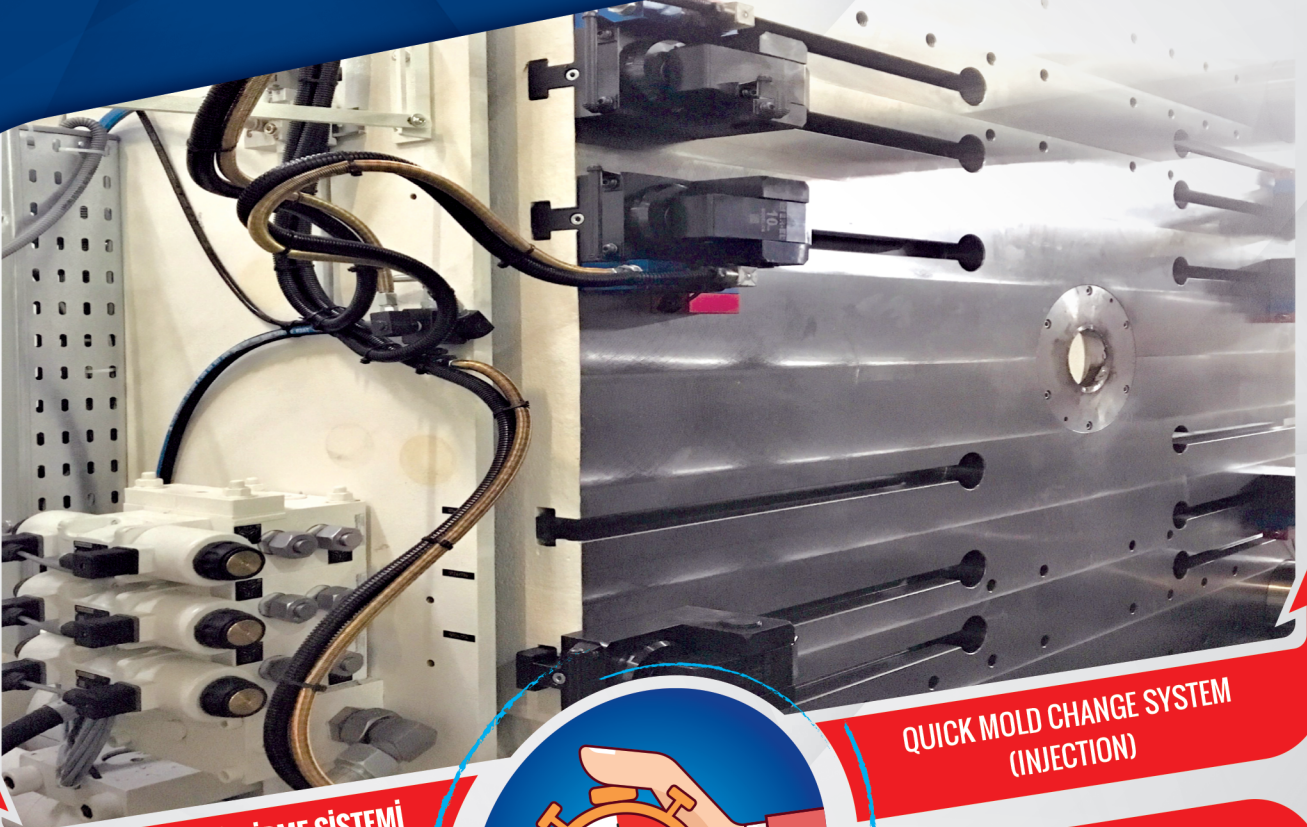

HIZLI KALIP DEĞİŞTİRME SİSTEMİ  
(ENJEKSİYON)

QUICK MOLD CHANGE SYSTEM  
(INJECTION)

HIZLI KALIP DEĞİŞTİRME SİSTEMİ  
(PRES)

QUICK DIE CHANGE SYSTEM  
(PRESS)





### Hızlı Kalıp Değişirme Sistemi

Kalıpların hızlı değiştiği, modellerin çeşitli ve üretim adetlerinin (talep miktarlarının) az olduğu zamanlarda kalıp değişirme süresini azaltıp iş güvenliğini sağlamaktır. Bu durumda **hızlı kalıp değişirme sistemine geçmenin tam vaktidir.**

#### Uygulama

- Pres - hidrolik pres - enjeksiyon
- Değişik otomatik makina bağlama sistemi

#### Application

- Press - hydraulic press - injection
- Different automatic machine clamp system

### Quick Die Change System

It's an era for making high frequency of die changing with multiple patterns and small quantity. In order to save die changing time and ensure operational safety, it is just in time to apply Quick Die Change System.

#### Elektronik Operasyon Kontrol Paneli Electronic Control Operation Panel

- Makineye bağlanmak için interlock kontrol switch donanımlıdır.
- It is equipped with interlock control switch for connecting to the machine.
- Oluşabilecek herhangi bir operasyon hatasını engellemek için güvenlik kontrol aygıtı ile birlikte tasarlanmıştır.
- It is designed with safety control device which prevents any operation error.
- PLC Uygulama mevcuttur.
- PLC Application available.

#### Kalıp Kaldırma / Die Lifter

**Model: DL - DB - DLS - DBS - DLP - DBP**

- Hidrolik tipi, yaylı tipi, pnömomatik tipi.
- Hydraulic type, spring type, pneumatic type.
- T veya U kanala kurulur.
- Install in the T-slot or U-slot.



#### Kalıp Kaydırma Kolu / Die Arm

**Model: RC - RD - RE/RF - RS - RSM**

- Tezgah pleyti üzerine kalıp kolayca itilebilir veya çekilebilir.
- Can pull out and push in the die from the plate easily.
- Kaydırma kolunun 4 ayrı modeli vardır.
- There are 4 different models of die arm.

#### Hava Tahrikli Hidrolik Pompa Ünitesi Air Driven Hydraulic Pump Unit

- Makinelerde basınç denetleme ve interlock özelliği.
- Capable of pressure inspection and interlocking with machines.
- Aygıtlar arası eşit seviyede hareket operasyon güvenliğini sağlar.
- The movements between each devices will be pinned down mutually in order to ensure operational safety.

#### Kalıp Pabucu / Die Clamp

**Model : CA - CAS - CV - CC - CB - CBS - CD**

- Kalıbı bağlamak için civata kullanılan geleneksel metodların yerini alır.
- Replacing the traditional method which uses screws to fix dies.
- Ürün T-Kanal pleytli tezgahlarda kullanılır.
- Using T-Slots to lock or fix directly on the plate.







**Kalıbı yükleyin.**

Bir vinç veya forklift kullanarak kalıbı yükleyin.  
Kalıp kaydırma kolu ile kolay yükleme imkanı sağlar.

**Load the die**

Load the die using a crane or forklift.  
The pre-rollers enable easy loading.

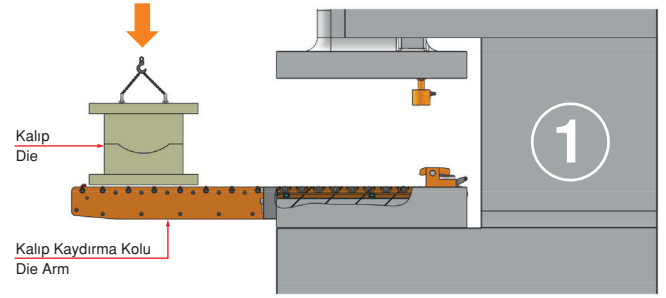
**Kalıbı pleyte aktarın.**

Kalıp kaydırma kolu kalıp kaldırımlarla kalıbı hareket ettirmek için çok az kuvvet gerekir. Kalıp kaldırımları T - / U - kanallarına yerleştirilmiştir.  
Kalıp kaldırma: Hidrolik basınç **ON**

**Transfer the die to the bolster.**

With the pre-rollers and die lifters, minimal force is required to move the die.  
Die lifters are set in the T - / U - slots.  
Die Lifter : Hydraulic pressure **ON**

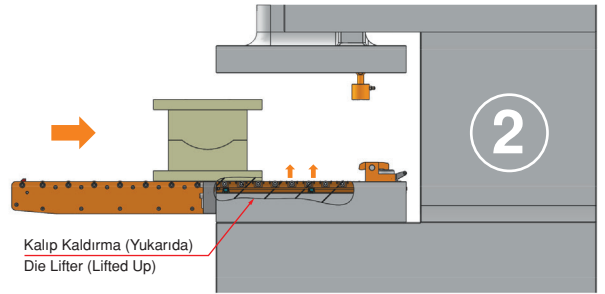
**Pleytin üzerinde kalıbı ayarlayın.**

Kontrol panelinden butona basarak kalıp kaldırmacı indirilir ve kalıp pleyte temas eder.  
Kalıp Kaldırma : Hidrolik Basınç **OFF**

**Set the die on the bolster.**

With push-button operation, the die lifter releases and the die makes contact with the bolster.  
Die Lifter : Hydraulic Pressure **OFF**

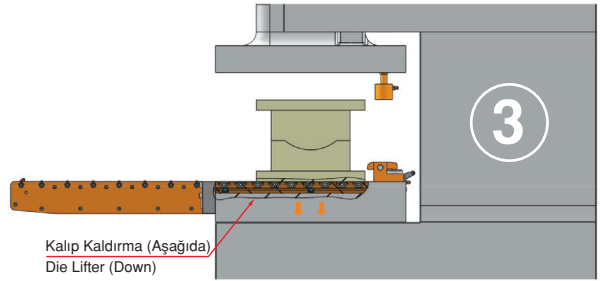
**Hidrolik pabuçları ayarlayın.**

Hidrolik pabuçları kalıba göre ayarlayın.  
Hidrolik pabuçları T kanalları üzerine kaydırarak kalıba yaklaştırın.  
Hidrolik Pabuç : Hidrolik Basınç **OFF**

**Set the automatic clamps.**

Set the slide to the bottom dead center .  
Slide automatic clamps on the T -slot and bring them near the die.  
Hydraulic Clamp : Hydraulic Pressure **OFF**

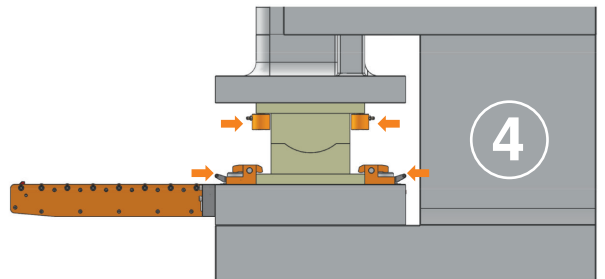
**Kalıbı kilitle.**

Kontrol panelinden butona basarak hidrolik pabuçlarla kalıbı kilitleyin.  
Güvenlik onayından sonra kalıp kaydırma kolu çıkarılabilir.  
Hidrolik Pabuç: Hidrolik Basıncı **ON**

**Lock the die.**

With push-button operation, automatic clamps lock the die.  
After safety confirmation, the pre-roller can be removed.  
Hydraulic Clamp : Hydraulic Pressure **ON**

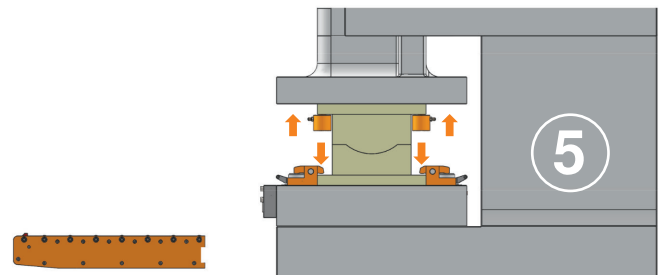



# HIZLI KALIP DEĞİŞTİRME SİSTEMİ

QUICK MOLD CHANGE SYSTEM

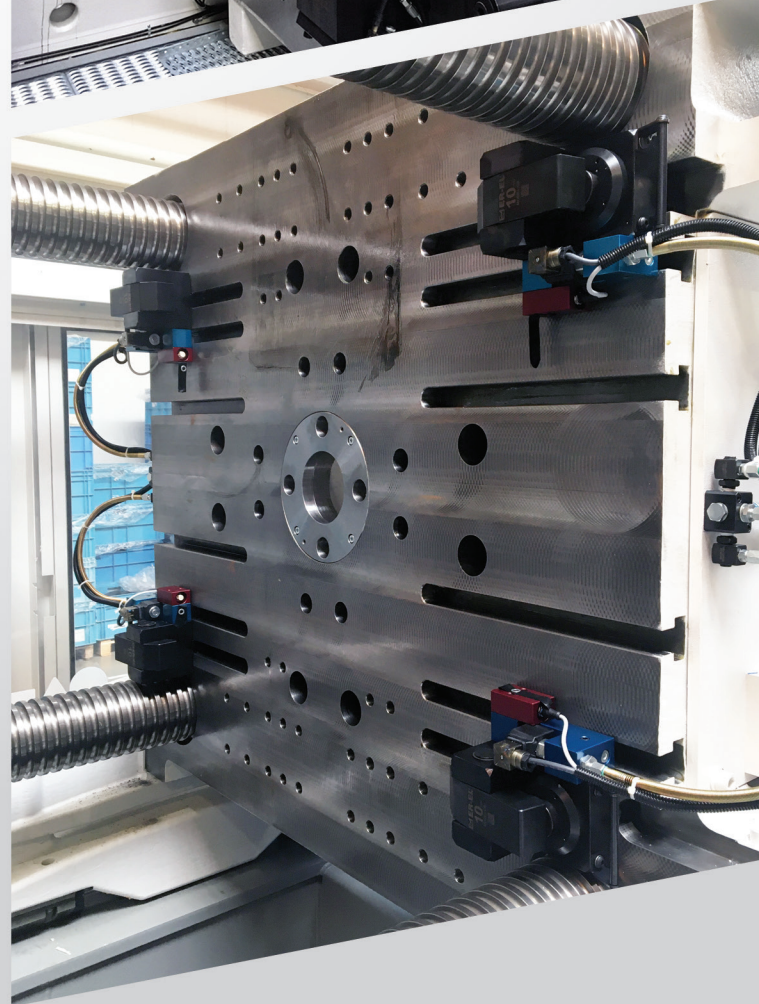
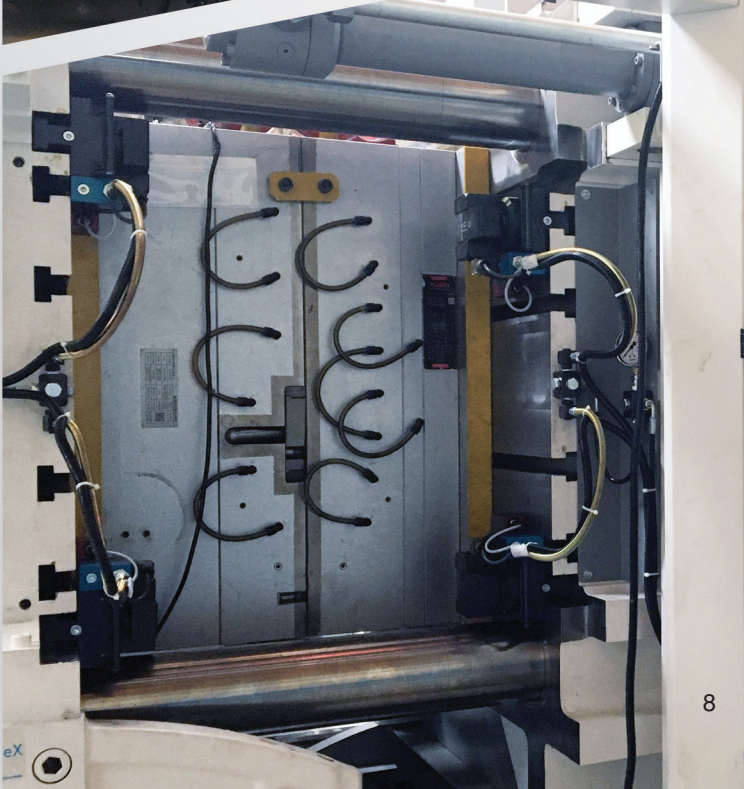



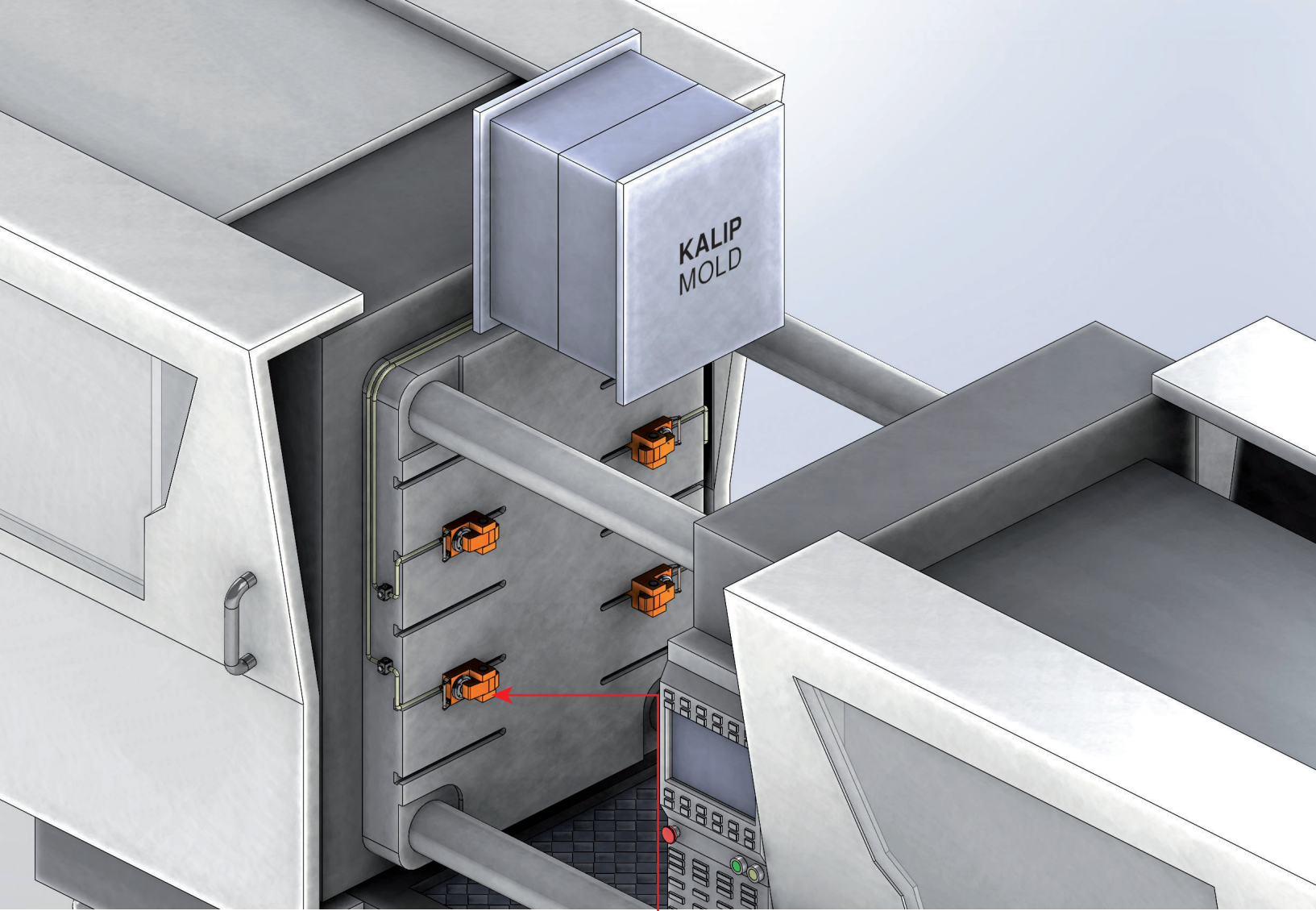

**Hidrolik Pabuç Modelleri / Hydraulic Clamp Models**



**Model CA**



**Model CV**



**Model CB**



**Model CBS**



**Model CC**



**Model CD**



**Model CG**

Model		CA-1	CA-2	CA-4	CA-6	CA-10	CA-16	CA-25
Bağlama kapasitesi Capacity of clamp	Ton	1	2	4	6	10	16	25
Toplam strok (X) Total stroke (X)	mm	6	8	8	8	8	8	8
Pabuç strok (Y) Stroke of clamp (Y)	mm	3	4	4	4	4	4	4
Muhafaza edilen strok (Z) Preserved stroke (Z)	mm	3	4	4	4	4	4	4
Silindirin toplam hacmi Total volumn of cylinder	cc	3	7	13	21	32	54	76
Kalıp taban kalınlığı toleransı (H) The tolerance of the template thickness (H)	mm	±1.5	±2	±2	±2	±2	±2	±2

Hidrolik basınç / Hydraulic pressure : 250kgf/cm<sup>2</sup>

Referans Nr.	ØF	E	ØG	ØJ	H+d max.	L max.	a min.	K	P
1010-CA01	44	48	12	30	60	12	8	9.5	PT1/8
1010-CA02	53	52	16	48	80	17	12	12	PT1/8
1010-CA04	65	58	23	58	90	20	16	15	PT1/4
1010-CA06	82	65	30	64	100	25	18	15	PT1/4
1010-CA10	99	71	38	78	110	30	22	15	PT1/4
1010-CA16	126	82	45	88	120	38	28	17	PT1/4
1010-CA25	150	100	55	98	140	45	36	23	PT1/4

#### Ürün Nr. 1010 Hidrolik Pabuç Model CA

- Pabuç ölçüleri (A), (B) ve (C) T-Kanala bağlı olarak belirlenir.
- Eğer pabuç ölçüsü (H+d) yukarıdaki maksimum değerlerden fazla ise, özel tasarım olarak kabul edilir.
- Standart Sıcaklık : 60°

#### Product Nr. 1010 Hydraulic Clamp Model CA

- The sizes of clamps (A),(B) and (C) are made based on the size of T slot.
- If the thickness of clamp (H+d) is more than the max. value listed on the left, it will be regarded as special pattern.
- Standard Temperature : 60°



- Satın almadan önce T-Kanal (a,b,c,d) ölçüsü ve kalıp tabanı kalınlığını (H) bildiriniz.
- Please indicate the size of T-slot (a,b,c,d) and the thickness (H) of the template for the die when purchasing.

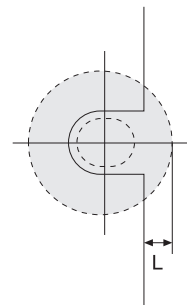
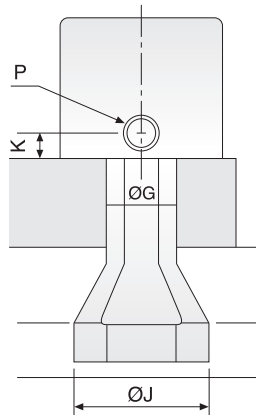
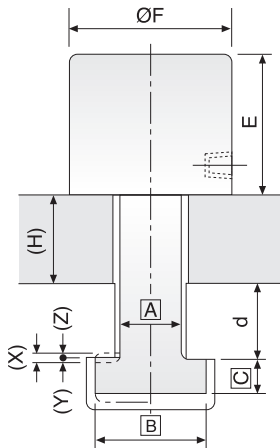
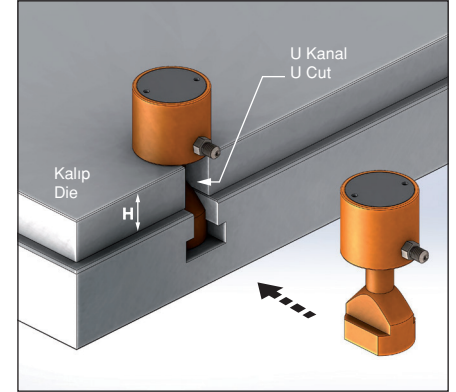

L: Pabuç için şablonun uzunluğu  
L: Template's length for clamp

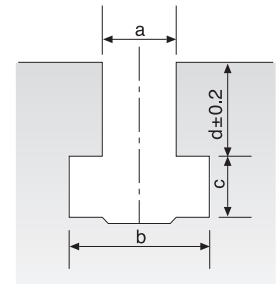



Referans Nr.	 min - max	Bağlanma Kapasitesi Capacity of Clamp	Strok Mesafesi Traveling Stroke (S)	Sürme Hızı Traveling Speed m/sec.	X	Z	ØF	E
1010-CAS04	28 - 32	27	-	1	8	4	65	62
1010-CAS06	28 - 32	36	-	1	8	4	82	69
1010-CAS10	28 - 32	42	-	1	8	4	99	75
1010-CAS16	28 - 32	51	-	1	8	4	126	86



## Ürün Nr. 1010 Pnömatik Slayt Konsol Model CAS

- Satın almadan önce strok mesafesini bildiriniz.
- Hidrolik Pabuç Basınç 250kgf/cm<sup>2</sup>
- Pnömatik Slayt Konsol Hava Barı Max. 10 bar

## Product Nr. 1010 Pneumatic Slide Console Model CAS

- Please inform the stroke distance before purchase
- Hydraulic clamp pressure 250kgf/cm
- Pneumatic Slide Console Air Bar Max.

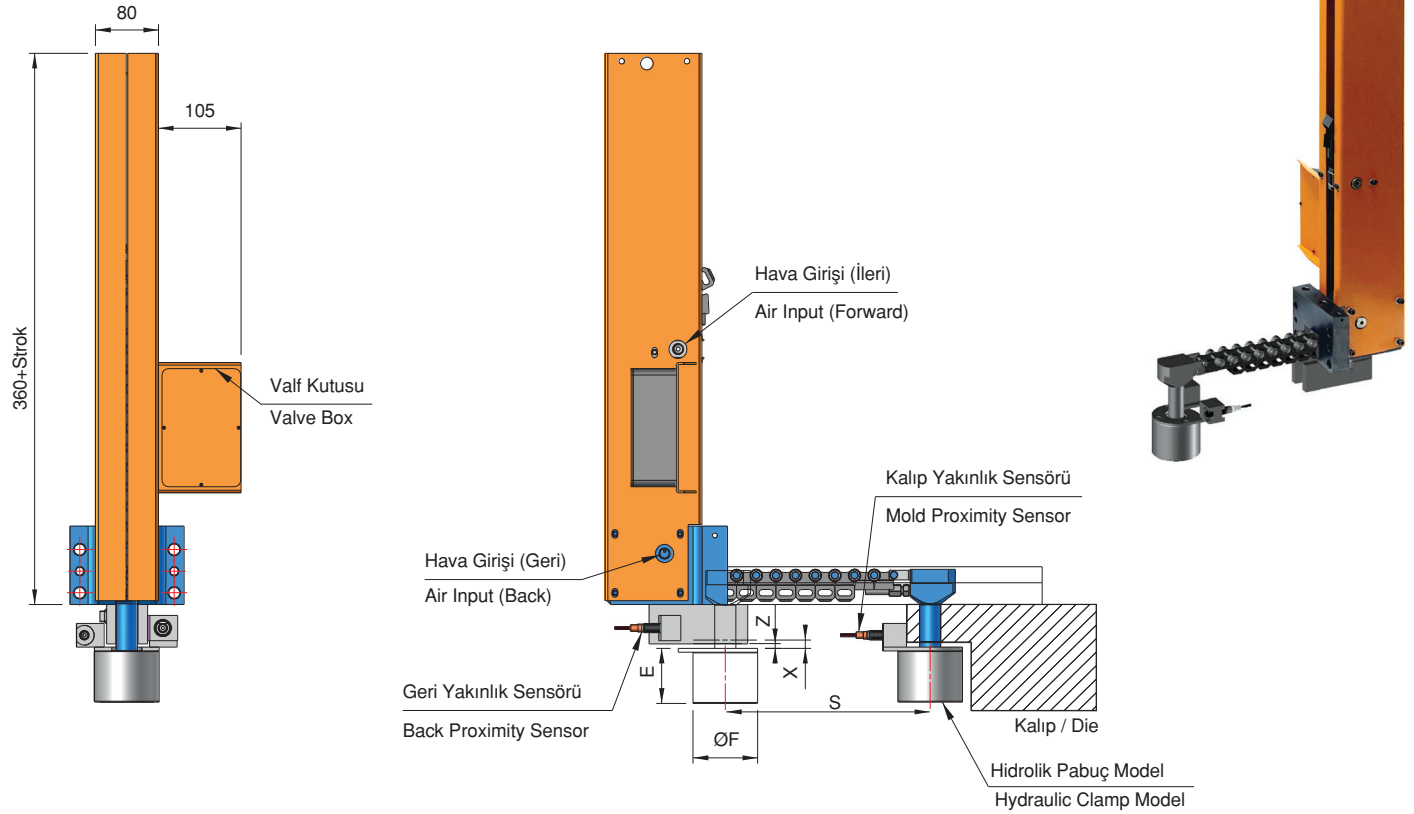

## Delik Delme Şablonu Hole Pattern for Installation

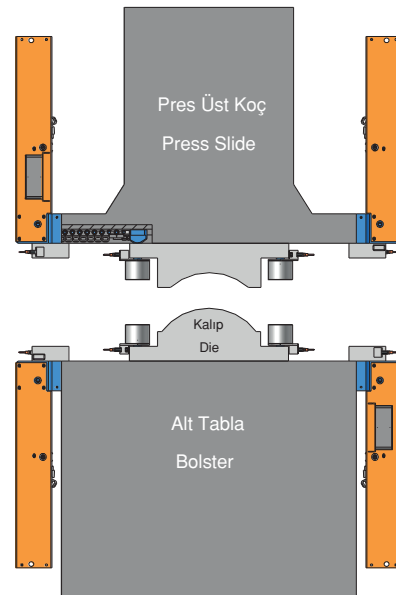
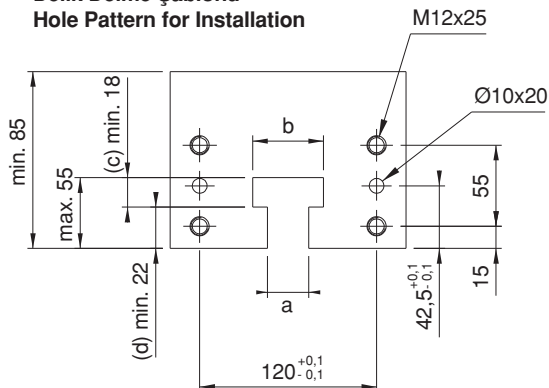

Model		CV-4	CV-6	CV-10
Bağlama kapasitesi Capacity of clamp	Ton	4	6	10
Toplam strok (X) Total stroke (X)	mm	8	8	8
Pabuç strok (Y) Stroke of clamp (Y)	mm	4	4	4
Muhafaza edilen strok (Z) Preserved stroke (Z)	mm	4	4	4
Silindirin toplam hacmi Total volumn of cylinder	cc	13	21	32
Kalıp taban kalınlığı toleransı (H) The tolerance of the template thickness (H)	mm	±2	±2	±2

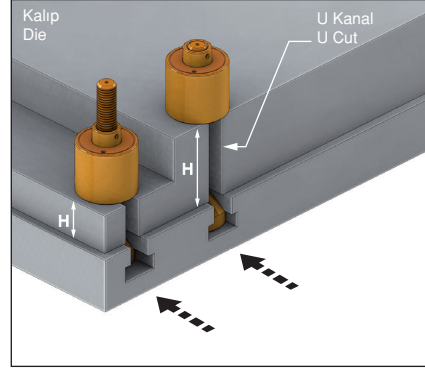

Hidrolik basınç / Hydraulic pressure : 250kgf/cm2

Referans Nr.		A	B	C	D	E + K1	Ayar Mesafesi	F	Max. L	M	ØG	ØJ	K	P
1010-CV042020125	20	19.6	32	12	85	70	15	65	125	M20	20	58	15	PT 1/4
1010-CV042020160	20	19.6	32	12	110	70	40	65	160	M20	20	58	15	PT 1/4
1010-CV042022125	22	21.6	35	14	85	70	15	65	125	M20	20	58	15	PT 1/4
1010-CV042022160	22	21.6	35	14	110	70	40	65	160	M20	20	58	15	PT 1/4
1010-CV062424125	24	23.6	40	16	85	77	8	82	125	M24	24	64	15	PT 1/4
1010-CV062424160	24	23.6	40	16	110	77	33	82	160	M24	24	64	15	PT 1/4
1010-CV062428125	28	27.6	44	18	85	77	8	82	125	M24	24	64	15	PT 1/4
1010-CV062428160	28	27.6	44	18	110	77	33	82	160	M24	24	64	15	PT 1/4
1010-CV102727160	27	26.6	46	18	110	83	27	99	160	M27	27	78	15	PT 1/4
1010-CV102727200	27	26.6	46	18	125	83	42	99	200	M27	27	78	15	PT 1/4
1010-CV102732160	32	31.6	50	20	110	83	27	99	160	M27	27	78	15	PT 1/4
1010-CV102732200	32	31.6	50	20	125	83	42	99	200	M27	27	78	15	PT 1/4
1010-CV103036160	36	35.6	56	23	110	83	27	99	160	M30	30	88	15	PT 1/4
1010-CV103036200	36	35.6	56	23	135	83	52	99	200	M30	30	88	15	PT 1/4
1010-CV103036250	36	35.6	56	23	150	83	67	99	250	M30	30	88	15	PT 1/4

### Ürün Nr. 1010 Hidrolik Pabuç Model CV

- Vidalanarak mesafe ayarı yapılabilir.
- Standart Sıcaklık : 60°

### Product Nr. 1010 Hydraulic Clamp Model CV

- Screw-distance adjustment can be made.
- Standard Temperature : 60°

### Önemli Not

- (Z) Muhafaza edilen strok ayar değişiminde kontrol edilmeli

### Notes

- The set stroke (Z) must be checked when changing the settings.

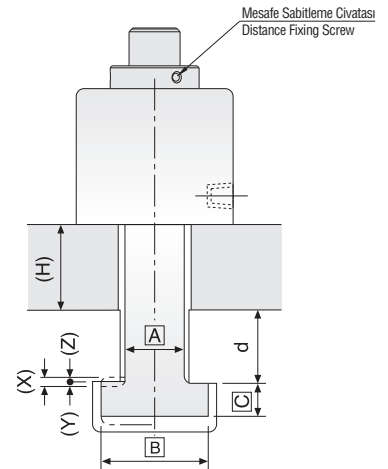
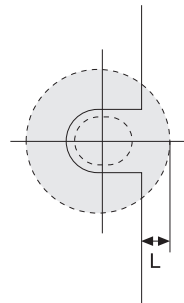
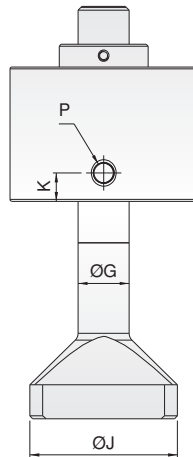
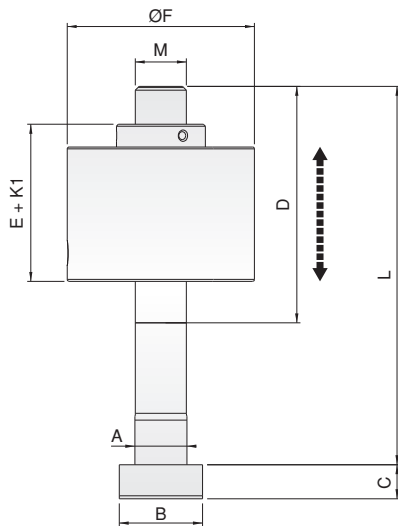

Model		CC-1	CC-2	CC-4	CC-6	CC-10
Bağlama kapasitesi Capacity of clamp	Ton	1	2	4	6	10
Toplam strok (X) Total stroke (X)	mm	9	9	9	12	12
Pabuç strok (Y) Stroke of clamp (Y)	mm	4	4	4	4	4
Muhafaza edilen strok (Z) Preserved stroke (Z)	mm	5	5	5	8	8
Silindirin toplam hacmi Total volumn of cylinder	cc	3	7.5	13	21	38
Kalıp taban kalınlığı toleransı (H) The tolerance of the template thickness (H)	mm	±1.5	±2	±2	±2	±2



- Satın almadan önce T-Kanal (a,b,c,d) ölçüsü ve kalıp tabanı kalınlığını (H) bildiriniz.
- Please indicate the size of T-slot (a,b,c,d) and the thickness (H) of the template for the die when purchasing.

Hidrolik basınç / Hydraulic pressure : 250kgf/cm<sup>2</sup>

Referans Nr.	H min. - max	A min.	C min.	E	F	G	I	J	K	L min.	M	T	U
1015-CC01	20-35	10	6.5	43	G+43	H+9	Ø16	75	33	27	21.5	1/8	M5
1015-CC02	25-40	14	10	50	G+50	H+9	Ø18	91	43	30	25	1/8	M5
1015-CC04	25-40	18	12	65	G+60	H+9	Ø30	115	55	40	32.5	1/8	M8
1015-CC06	35-55	22	14	80	G+65	H+12	Ø37.5	130	65	48	40	1/4	M10
1015-CC10	40-60	24	16	100	G+82	H+12	Ø50	160	85	60	49	1/4	M12

### Ürün Nr. 1015 Hidrolik Pabuç Model CC

- Pabuç ölçüleri (A),(B),(C) ve (D) T-Kanala bağlı olarak belirlenir.
- Standart Sıcaklık : 60°

### Product Nr. 1015 Hydraulic Clamp Model CC

- The sizes of clamps(A),(B),(C) and (D) are made based on the size of T-slot.
- Standard Temperature : 60°

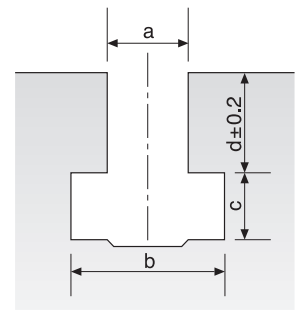
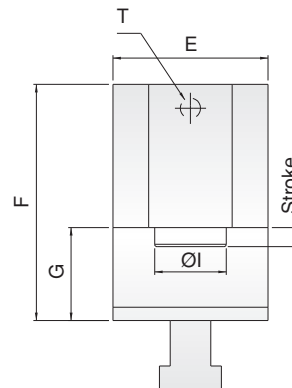
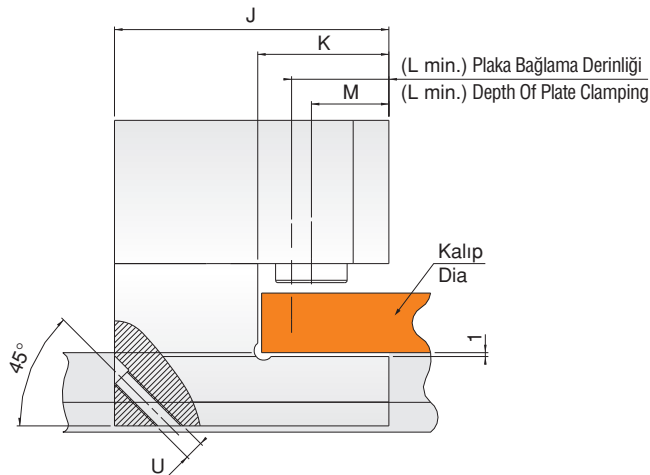
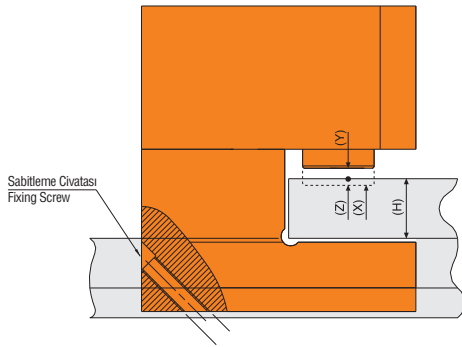
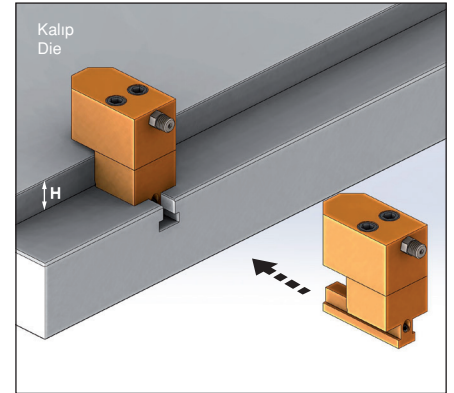





Model		CCM-1	CCM-2	CCM-4	CCM-6	CCM-10
Bağlama kapasitesi Capacity of clamp	Ton	1	2	4	6	10
Toplam strok (X) Total stroke (X)	mm	9	9	9	12	12
Pabuç strok (Y) Stroke of clamp (Y)	mm	4	4	4	4	4
Muhafaza edilen strok (Z) Preserved stroke (Z)	mm	5	5	5	8	8
Silindirin toplam hacmi Total volumn of cylinder	cc	3	7.5	13	21	38
Kalıp taban kalınlığı toleransı (H) The tolerance of the template thickness (H)	mm	±1.5	±2	±2	±2	±2

Hidrolik basınç / Hydraulic pressure : 250kgf/cm<sup>2</sup>

- Satın almadan önce T-Kanal (a,b,c,d) ölçüsü ve kalıp tabanı kalınlığını (H) bildiriniz.
- Please indicate the size of T-slot (a,b,c,d) and the thickness (H) of the template for the die when purchasing.

Referans Nr.	H min. - max Mesafe Ayarlı Distance Adjustable	A min.	C min.	E	G	I	J	K	L min.	M	T	U
1015-CCM01	20-35	10	6.5	43	H+9	Ø16	75	33	27	21.5	1/8	M5
1015-CCM02	25-40	14	10	50	H+9	Ø18	91	43	30	25	1/8	M5
1015-CCM04	25-40	18	12	65	H+9	Ø30	115	55	40	32.5	1/8	M8
1015-CCM06	35-55	22	14	80	H+12	Ø37.5	130	65	48	40	1/4	M10
1015-CCM10	40-60	24	16	100	H+12	Ø50	160	85	60	49	1/4	M12

### Ürün Nr. 1015 Hidrolik Pabuç Model CCM

- Pabuç ölçüleri (A),(B),(C) ve (D) T-Kanala bağlı olarak belirlenir.
- Standart Sıcaklık : 60°

### Product Nr. 1015 Hydraulic Clamp Model CCM

- The sizes of clamps(A),(B),(C) and (D) are made based on the size of T-slot.
- Standard Temperature : 60°

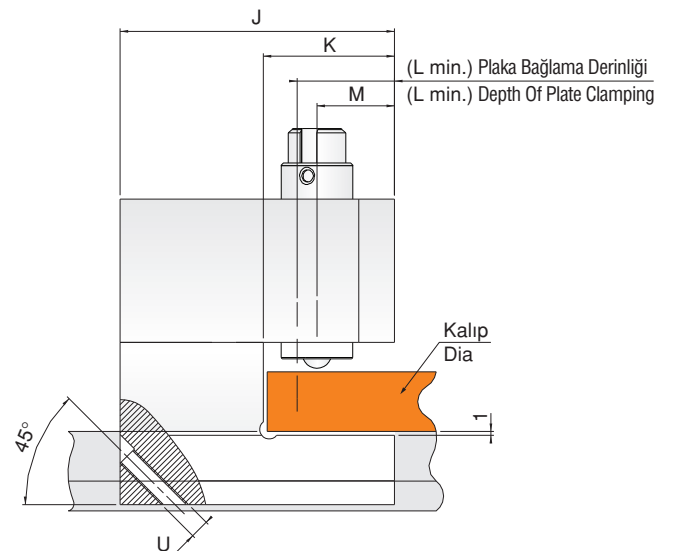
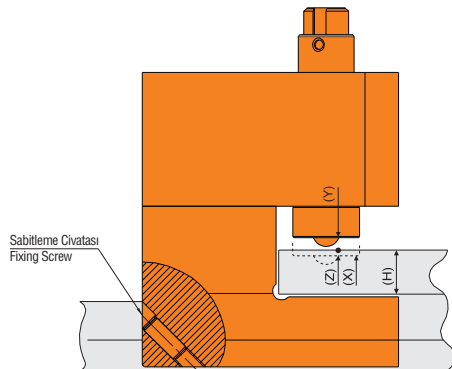
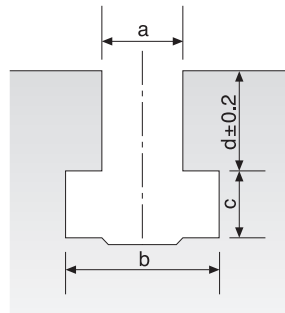
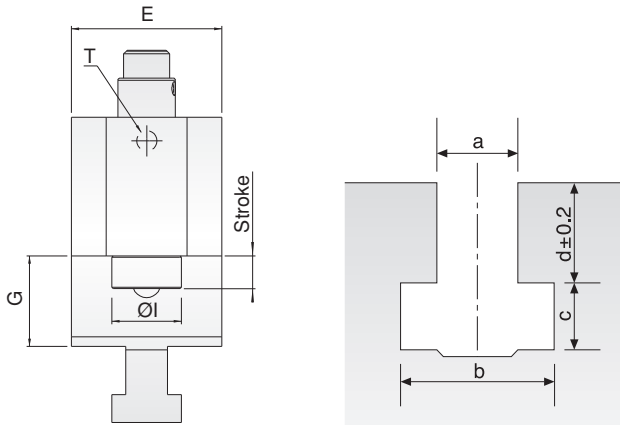
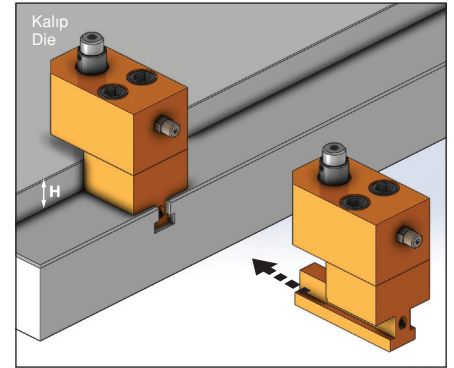

Referans Nr.	L	K	J	H min.	H+d min. max	E min.	F	G	a min.	C min.	P
1015-CB01	74.5	60	14.5	25	100	42	44	20	10	6.5	PT1/8
1015-CB02	110	90	20	25	100	73	68	32	14	10	PT1/4
1015-CB04	134	110	24	25	130	77	79	40	18	12	PT1/4
1015-CB06	159	130	29	30	150	92	96	46	22	14	PT1/4
1015-CB10	189	159	30	40	140	114	117	54	24	16	PT1/4
1015-CB16	230	200	30	40	130	126	129	58	28	20	PT1/4
1015-CB25	265	235	30	45	120	148	156	70	36	23	PT1/4



Model	CB-1	CB-2	CB-4	CB-6	CB-10	CB-16	CB-25
	CBL-1	CBL-2	CBL-4	CBL-6	CBL-10	CBL-16	CBL-25
Bağlama kapasitesi Capacity of clamp	1	2	4	6	10	16	25
Toplam strok (X) Total stroke (X)	6	8	8	8	8	8	8
Pabuç strok (Y) Stroke of clamp (Y)	2.5	3	3	3	3	3	3
Muhafaza edilen strok (Z) Preserved stroke (Z)	3.5	5	5	5	5	5	5
Silindirin toplam hacmi Total volumn of cylinder	3	7.5	13	21	38	55	98
Kalıp taban kalınlığı toleransı (H) The tolerance of the template thickness (H)	±1.5	±2	±2	±2	±2	±2	±2

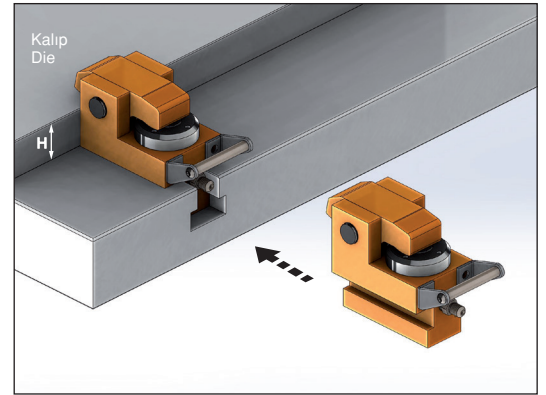

#### Ürün Nr. 1015 Hidrolik Pabuç Model CB

- Pabuç ölçüleri (A),(B),(C) ve (D) T-Kanala bağlı olarak belirlenir.
- Standart Sıcaklık : 60°
- Hidrolik basınç 250kgf/cm2

#### Product Nr. 1015 Hydraulic Clamp Model CB

- The sizes of clamps(A),(B),(C) and (D) are made based on the size of T-slot.
- Standard Temperature : 60°
- Hydraulic pressure : 250kgf/cm2

- Satın almadan önce T-Kanal (a,b,c,d) ölçüsü ve kalıp tabanı kalınlığını (H) bildiriniz.
- Please indicate the size of T-slot (a,b,c,d) and the thickness (H) of the template for the die when purchasing.

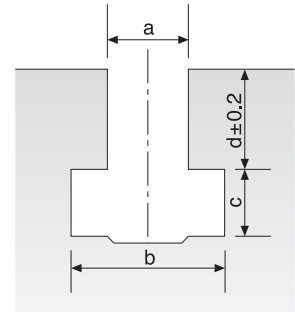
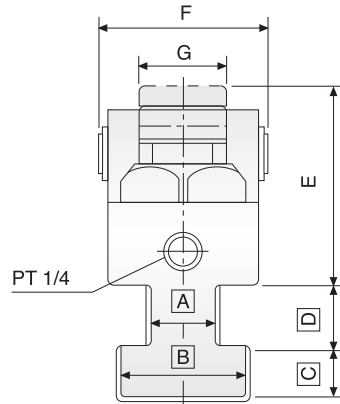
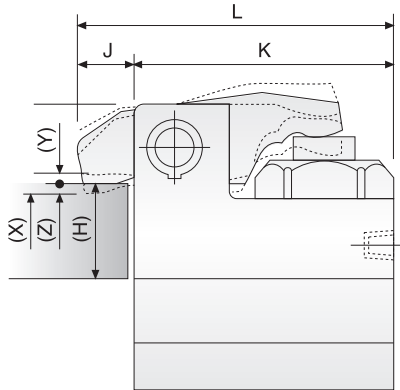

Referans Nr.	L	K	J	H min.	H+d min. max	E min.	F	G	a min.	C min.	P
1015-CBL01	74.5	60	14.5	25	100	42	44	20	10	6.5	PT1/8
1015-CBL02	110	90	20	25	100	73	68	32	14	10	PT1/4
1015-CBL04	134	110	24	25	130	77	79	40	18	12	PT1/4
1015-CBL06	159	130	29	30	150	92	96	46	22	14	PT1/4
1015-CBL10	189	159	30	40	140	114	117	54	24	16	PT1/4
1015-CBL16	230	200	30	40	130	126	129	58	28	20	PT1/4
1015-CBL25	265	235	30	45	120	148	156	70	36	23	PT1/4

## Hidrolik Pabuç Model CBL

### Hydraulic Clamp Model CBL

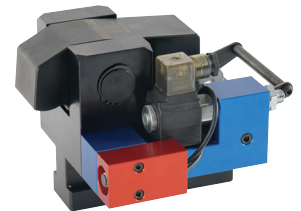

#### Ürün Nr. 1015 Hidrolik Pabuç Model CBL

- Pabuç ölçüleri (A),(B),(C) ve (D) T-Kanala bağlı olarak belirlenir.
- Standart Sıcaklık : 60°
- Hidrolik basınç 250kgf/cm2

#### Product Nr. 1015 Hydraulic Clamp Model CBL

- The sizes of clamps(A),(B),(C) and (D) are made based on the size of T-slot.
- Standard Temperature : 60°
- Hydraulic pressure : 250kgf/cm2

☑ Not  
Kilitleme seçeneği

☑ Note  
With locking option



Model		CBS-1	CBS-2	CBS-4	CBS-6	CBS-10	CBS-16	CBS-25
Bağlama kapasitesi Capacity of clamp	Ton	1	2	4	6	10	16	25
Toplam strok (X) Total stroke (X)	mm	6	8	8	8	8	8	8
Pabuç strok (Y) Stroke of clamp (Y)	mm	2.5	3	3	3	3	3	3
Muhafaza edilen strok (Z) Preserved stroke (Z)	mm	3.5	5	5	5	5	5	5
Silindirin toplam hacmi Total volumn of cylinder	cc	3	7.5	13	21	38	55	98
Kalıp taban kalınlığı toleransı (H) The tolerance of the template thickness (H)	mm	±1.5	±2	±2	±2	±2	±2	±2
Strok Mesafesi (S) Traveling Stroke (S)								

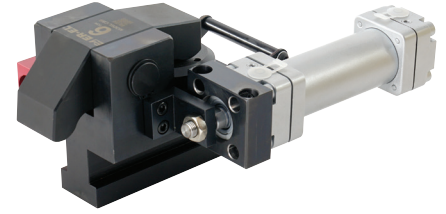

- Satın almadan önce T-Kanal (a,b,c,d) ölçüsü ve kalıp tabanı kalınlığını (H) bildiriniz.
- Please indicate the size of T-slot (a,b,c,d) and the thickness (H) of the template for the die when purchasing.

Satın almadan önce strok mesafesini bildiriniz.  
Hidrolik Basınç : 250kgf/cm<sup>2</sup>

Please inform the stroke distance before purchase.  
Hydraulic pressure : 250kgf/cm<sup>2</sup>

Referans Nr.	L	K	J	H min.	H+d min. max	E min.	F	G	a min.	C min.	P
1015-CBS01	74.5	60	14.5	25	100	42	44	20	10	6.5	PT1/8
1015-CBS02	110	90	20	25	100	73	68	32	14	10	PT1/4
1015-CBS04	134	110	24	25	130	77	79	40	18	12	PT1/4
1015-CBS06	159	130	29	30	150	92	96	46	22	14	PT1/4
1015-CBS10	189	159	30	40	140	114	117	54	24	16	PT1/4
1015-CBS16	230	200	30	40	130	126	129	58	28	20	PT1/4
1015-CBS25	265	235	30	45	120	148	156	70	36	23	PT1/4

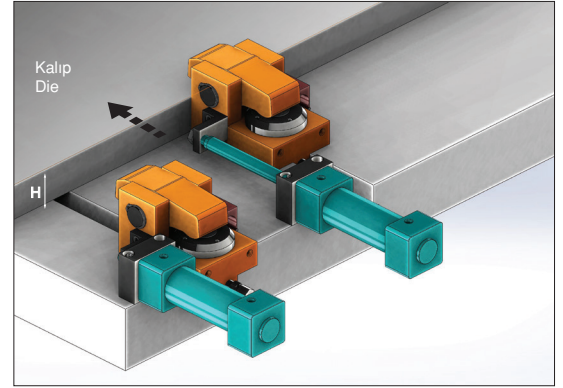

### Ürün Nr. 1015 Hidrolik Pabuç Model CBS

- Pabuç ölçüleri (A),(B),(C) ve (D)
- T-Kanala bağlı olarak belirlenir.
- Standart Sıcaklık : 60°

### Product Nr. 1015 Hydraulic Clamp Model CBS

- The sizes of clamps(A),(B),(C) and (D)
- are made based on the size of T-slot.
- Standard Temperature : 60°

**Not**  
Otomatik komut ile ilerler.

**Note**  
Proceeds with automatic command.

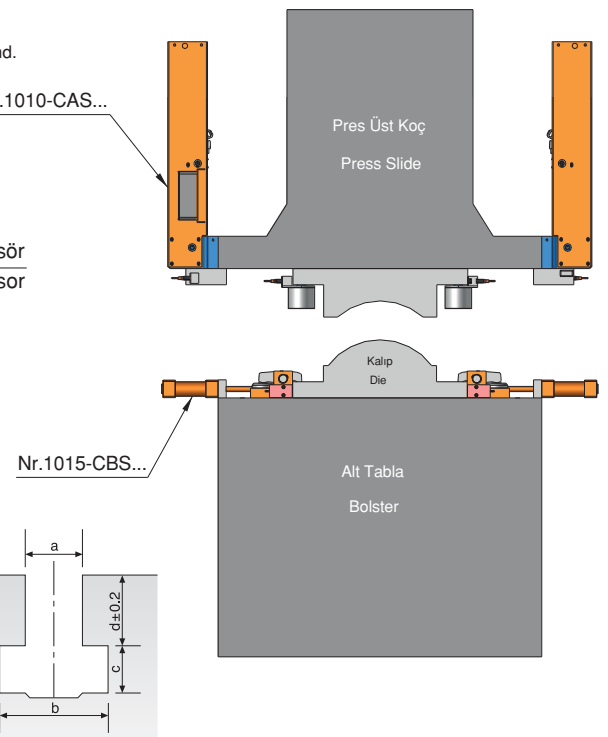
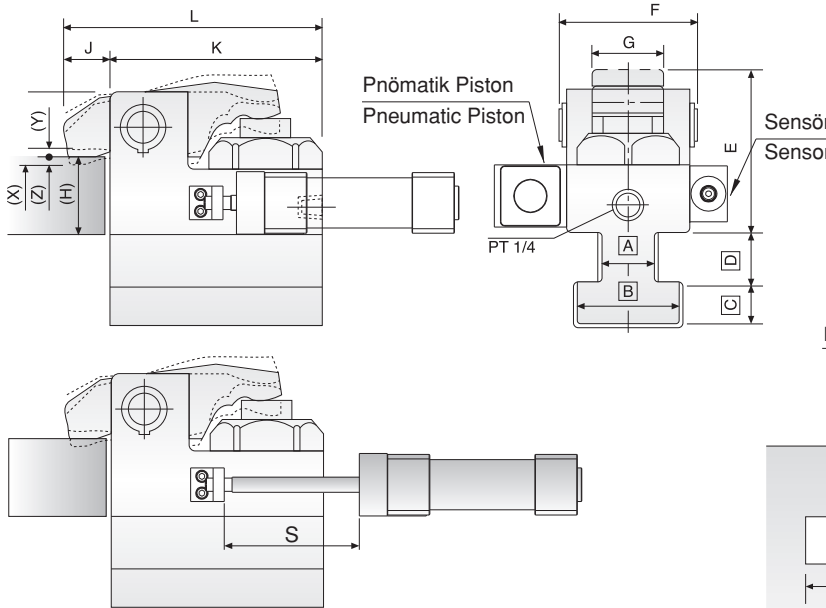



Model		CD-2	CD-4	CD-6	CD-10	CD-16	CD-25
Bağlama kapasitesi Capacity of clamp	Ton	2	4	6	10	16	25
Toplam strok (X) Total stroke (X)	mm	8	8	8	8	8	8
Pabuç strok (Y) Stroke of clamp (Y)	mm	3	3	3	3	3	3
Muhafaza edilen strok (Z) Preserved stroke (Z)	mm	5	5	5	5	5	5
Silindirin toplam hacmi Total volumn of cylinder	cc	7.5	13	21	38	55	98
Kalıp taban kalınlığı toleransı (H) The tolerance of the template thickness (H)	mm	±2	±2	±2	±2	±2	±2

Hidrolik basınç / Hydraulic pressure : 250kgf/cm<sup>2</sup>

Referans Nr.	A	B	C	D	E min.	F	G	W	N max.	T
1015-CD02	12	20	80	98	90	76	30	124	25	M10x20D
1015-CD04	12	25	100	109	93	87	30	135	30	M12x24D
1015-CD06	15	30	120	126	109	104	30	152	35	M12x24D
1015-CD10	15	35	150	148	131	124	36	174	40	M14x28D
1015-CD16	20	40	200	166	142	138	44	200	50	M18x36D
1015-CD25	20	45	235	200	163	168	48	240	60	M22x45D

### Ürün Nr. 1015 Hidrolik Pabuç Model CD

• Standart Sıcaklık : 60°

### Product Nr. 1015 Hydraulic Clamp Model CD

• Standard Temperature : 60°

#### Not

Pleyti dişli tezgahlarda kullanım olanağı sağlar.

#### Note

It can be used in machines with holes on the plate.

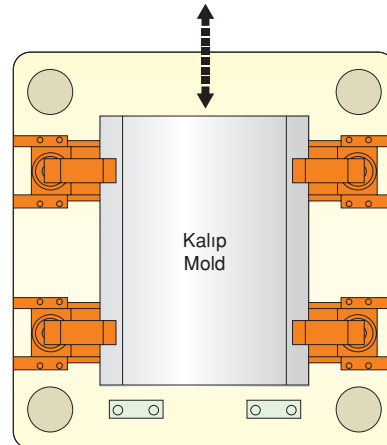
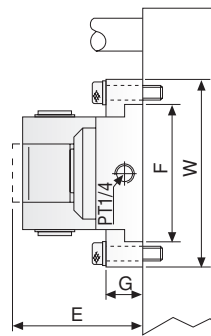
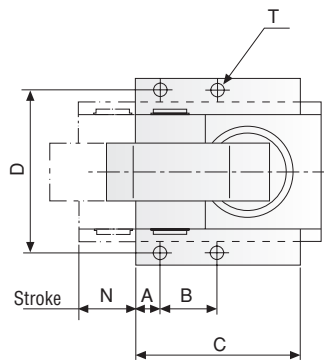





Model		CG-4	CG-6	CG-10	CG-16	CG-25	CG-50
Bağlama kapasitesi Capacity of clamp	Ton	4	6	10	16	25	50
Yay kuvveti Retaining force	Ton	0.80	1.2	2	3.2	5	10
Muhafaza edilen strok (Z) Preserved stroke (Z)	mm	1.5	1.5	2	2	2	2

Hidrolik basınç / Hydraulic pressure : 250kgf/cm<sup>2</sup>

- Satın almadan önce kalıp tabanı kalınlığını (H) bildiriniz.
- Please thickness (H) of the template for the die when purchasing.

Referans Nr.	I	J	K	L	M	N	O	P	Q	Rc	H	T
1015-CG04	17	2	27	90	62	35	14	-	115	1/4	25	M16
1015-CG06	19	3	33	110	76	45	17	-	124	1/4	30	M20
1015-CG10	23	3	36	135	95	50	20	-	131	1/4	30	M24
1015-CG16	28	5	33	138	104	60	17	40	156	1/4	30	M20
1015-CG25	33	5	40	170	130	75	20	50	188	1/4	40	M24
1015-CG50	35	5	50	215	162	100	27	60	227	3/8	50	M33

#### Ürün Nr. 1015 Hidrolik Pabuç Model CG

- Standart Sıcaklık : 60°

#### Product Nr. 1015 Hydraulic Clamp Model CG

- Standard Temperature : 60°

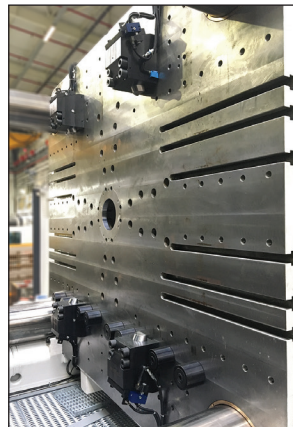
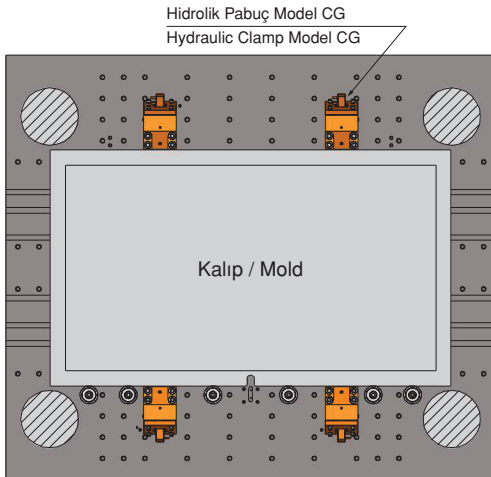
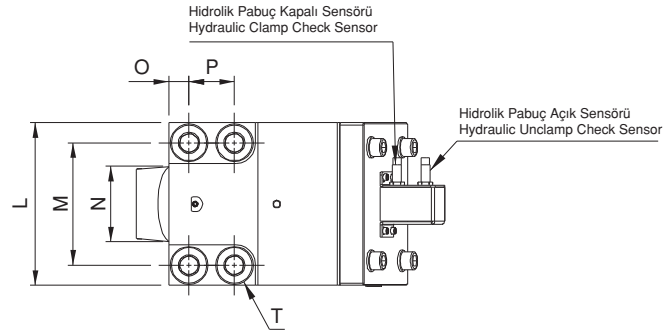
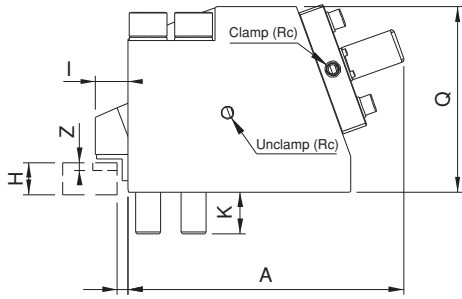

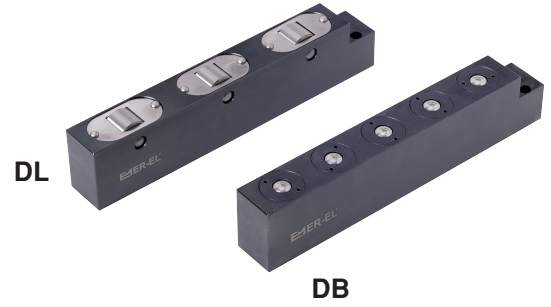
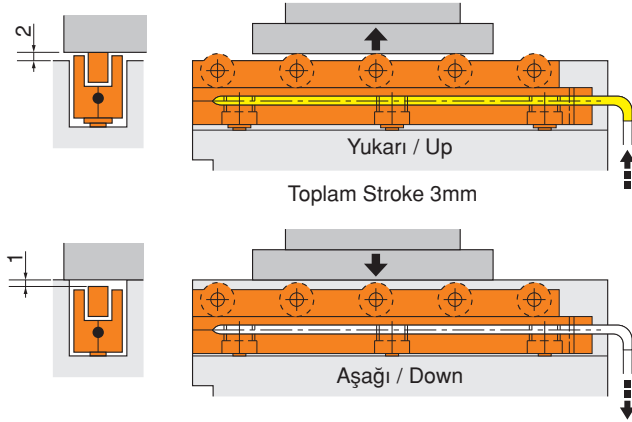

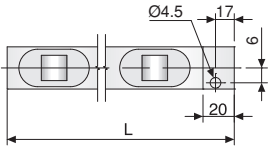
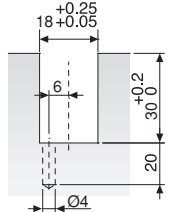
Dış Ölçüler Outline Dimensions	D□18 Serisi / Serial
	
Pleyt için işlem ölçüsü (U-Kanal) Processing Size for Plate (U-slot)	

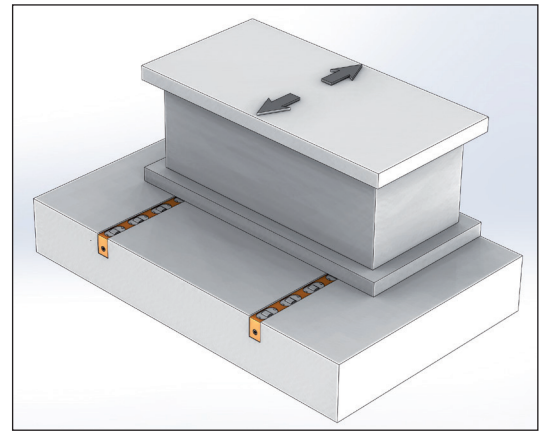

Model DL Hareket Yönü  
Model DL Movement Direction

Referans Nr.	L	D□18				Hid. Silindir Hyd. cylinder	
		DL18		DB18		Piston	Kapasite Capacity kg
		Rulo Roller (DL)	Kapasite Capacity kg	Misket Ball (DB)	Kapasite Capacity kg		
1020-0200	200	3	300	5	250	2	560
1020-0300	300	5	500	7	350		
1020-0400	400	6	560	10	500		
1020-0500	500	8	800	12	600	3	840
1020-0600	600	9	840	15	750		
1020-0700	700	11	840	17	840		
1020-0800	800	12	1120	20	1000	4	1120
1020-0900	900	14	1120	22	1100		
1020-1000	1000	15	1250	25	1250		

**Ürün Nr. 1020 Hidrolik Kalıp Kaldırma Model DL-DB**

- Standart Sıcaklık : 60°
- Hidrolik Basınç : 250kgf/cm<sup>2</sup>

**Product Nr. 1020 Die Lifter Hydraulic Model DL-DB**

- Standard Temperature : 60°
- Hydraulic Pressure : 250kgf/cm<sup>2</sup>

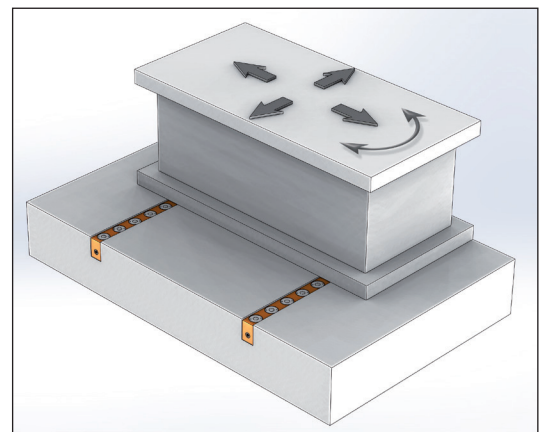

Model DB Hareket Yönü  
Model DB Movement Direction



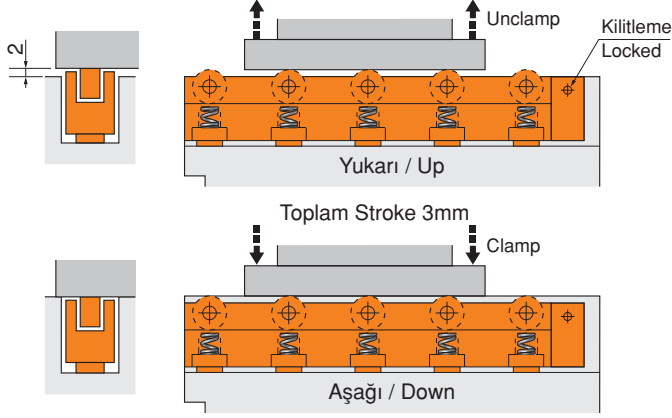

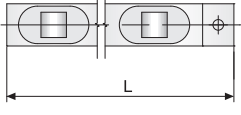
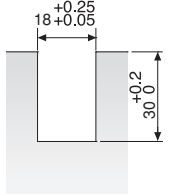

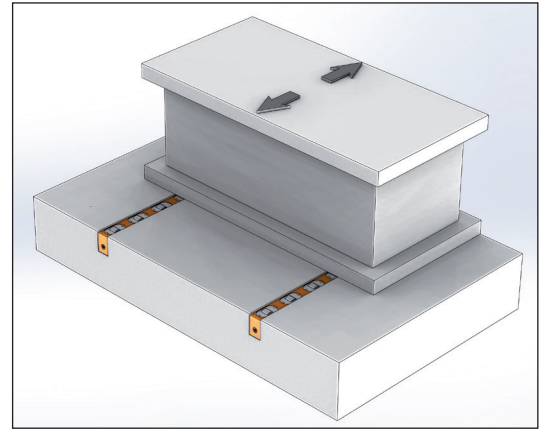
Dış Ölçüler Outline Dimensions	D□18 Serisi / Serial
	
Pleyt için işlem ölçüsü (U-Kanal) Processing Size for Plate (U-slot)	



Model DLS Hareket Yönü  
Model DLS Movement Direction

Referans Nr.	L	D□18					
		DLS18			DBS18		
		Rulo Roller (DLS)		Kapasite Capacity kg	Misket Ball (DBS)		Kapasite Capacity kg
1022-0200	200	3	4	200	5	6	150
1022-0300	300	5	6	300	7	8	200
1022-0400	400	6	7	350	10	11	275
1022-0500	500	8	9	450	12	13	325
1022-0600	600	9	10	500	15	16	400
1022-0700	700	11	12	600	17	18	450
1022-0800	800	12	13	650	20	21	525
1022-0900	900	14	15	750	22	23	575
1022-1000	1000	15	16	800	25	26	650

Ürün Nr. 1022 Yaylı Kalıp Kaldırma Model DLS-DBS  
• Standart Sıcaklık : 60°

Product Nr. 1022 Die Lifter Spring Model DLS-DBS  
• Standard Temperature : 60°

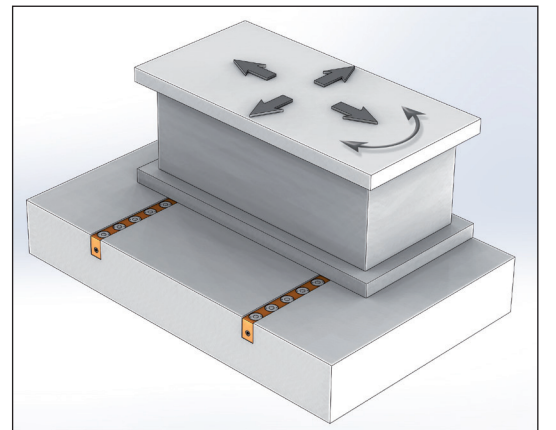

Model DBS Hareket Yönü  
Model DBS Movement Direction

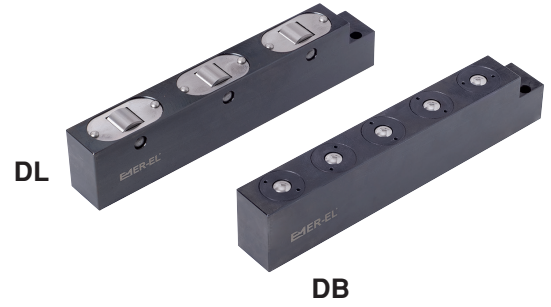
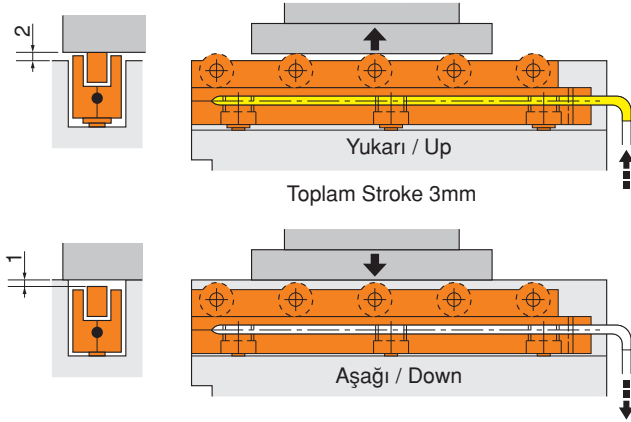

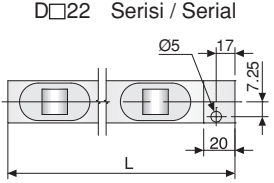
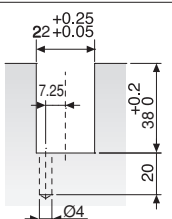
Dış Ölçüler Outline Dimensions	 <p>D□22 Serisi / Serial</p>
Pleyt için işlem ölçüsü (U-Kanal) Processing Size for Plate (U-slot)	

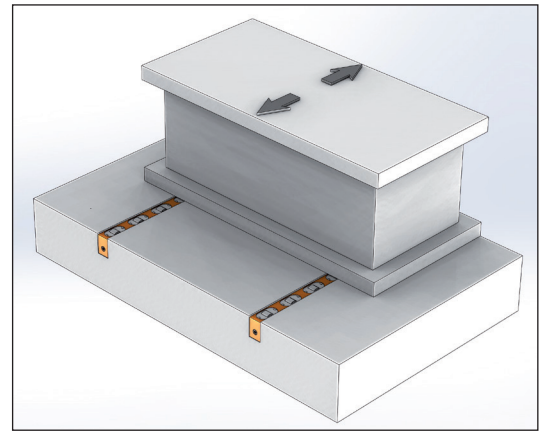

Model DL Hareket Yönü  
Model DL Movement Direction

Referans Nr.	L	D□22				Hid. Silindir Hyd. cylinder	
		DL22		DB22		Piston	Kapasite Capacity kg
		Rulo Roller (DL)	Kapasite Capacity kg	Misket Ball (DB)	Kapasite Capacity kg		
1020-0200	200	3	480	5	370	2	1000
1020-0300	300	5	800	7	518		
1020-0400	400	6	960	10	740		
1020-0500	500	8	1280	12	888	3	1500
1020-0600	600	9	1400	15	1110		
1020-0700	700	11	1500	17	1250		
1020-0800	800	12	1920	20	1480		
1020-0900	900	14	2000	22	1628	4	2000
1020-1000	1000	15	2000	25	1850		

**Ürün Nr. 1020 Hidrolik Kalıp Kaldırma Model DL-DB**

- Standart Sıcaklık : 60°
- Hidrolik Basınç : 250kgf/cm<sup>2</sup>

**Product Nr. 1020 Die Lifter Hydraulic Model DL-DB**

- Standard Temperature : 60°
- Hydraulic Pressure : 250kgf/cm<sup>2</sup>

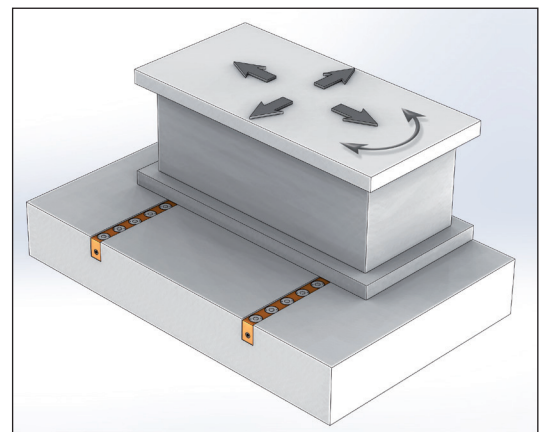

Model DB Hareket Yönü  
Model DB Movement Direction



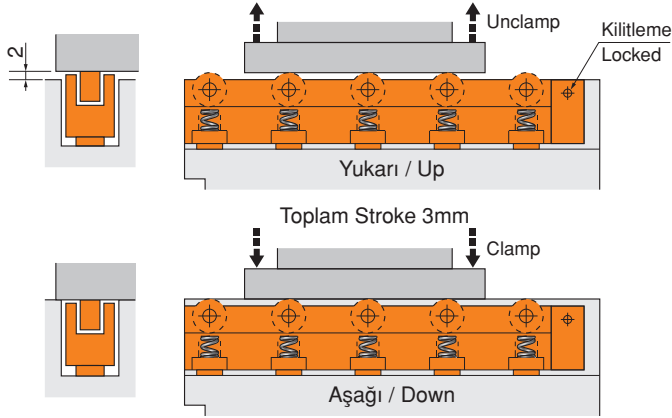

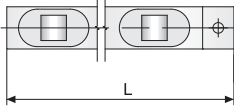
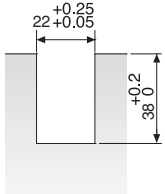

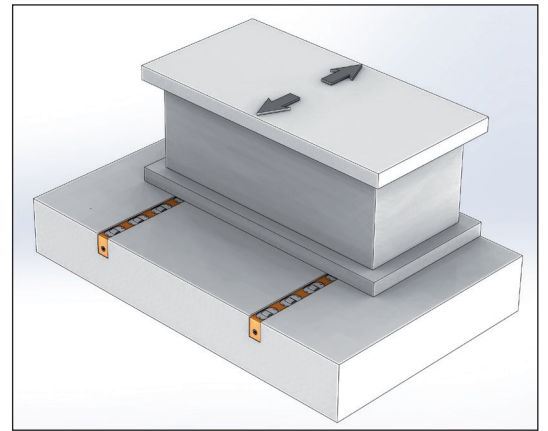
Dış Ölçüler Outline Dimensions	D□22 Serisi / Serial
	
Pleyt için işlem ölçüsü (U-Kanal) Processing Size for Plate (U-slot)	



Model DLS Hareket Yönü  
Model DLS Movement Direction

Referans Nr.	L	D□22					
		DLS22			DBS22		
		Rulo Roller (DLS)		Kapasite Capacity kg	Misket Ball (DBS)		Kapasite Capacity kg
1022-0200	200	3	4	320	5	6	240
1022-0300	300	5	6	480	7	8	320
1022-0400	400	6	7	560	10	11	440
1022-0500	500	8	9	720	12	13	520
1022-0600	600	9	10	800	15	16	640
1022-0700	700	11	12	960	17	18	720
1022-0800	800	12	13	1040	20	21	840
1022-0900	900	14	15	1200	22	23	920
1022-1000	1000	15	16	1280	25	26	1040

Ürün Nr. 1022 Yaylı Kalıp Kaldırma Model DLS-DBS  
• Standart Sıcaklık : 60°

Product Nr. 1022 Die Lifter Spring Model DLS-DBS  
• Standard Temperature : 60°

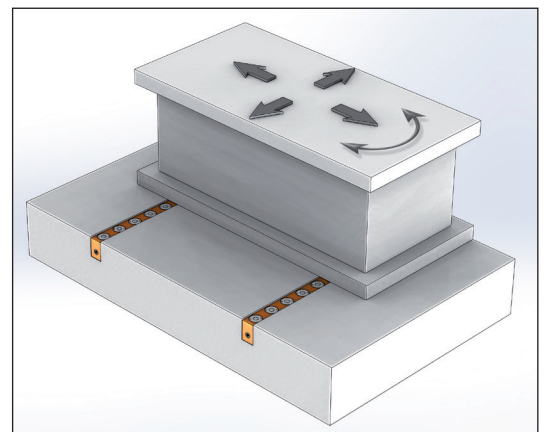

Model DBS Hareket Yönü  
Model DBS Movement Direction

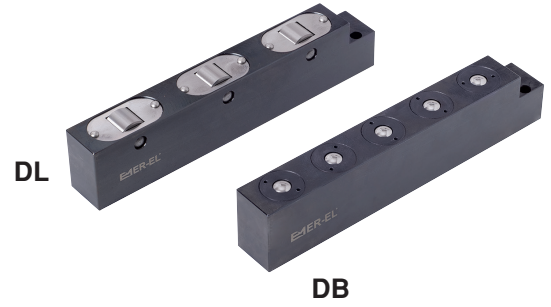
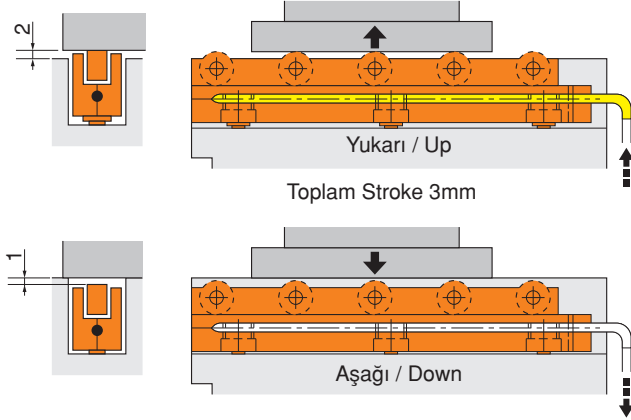

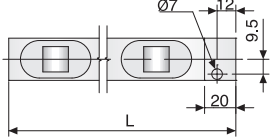
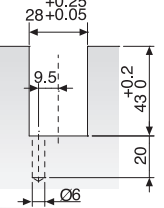
Dış Ölçüler Outline Dimensions	□28 Serisi / Serial
	
Pleyt için işlem ölçüsü (U-Kanal) Processing Size for Plate (U-slot)	

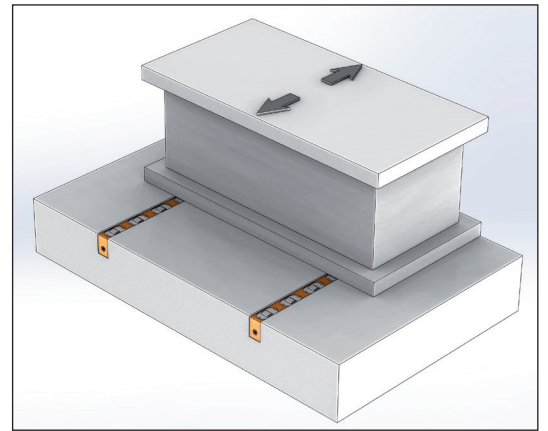

Model DL Hareket Yönü  
Model DL Movement Direction

Referans Nr.	L	□28				Hid. Silindir Hyd. cylinder	
		DL28		DB28		Piston	Kapasite Capacity kg
		Rulo Roller (DL)	Kapasite Capacity kg	Misket Ball (DB)	Kapasite Capacity kg		
1020-0200	200	3	750	5	475	2	1260
1020-0300	300	5	1250	7	665		
1020-0400	400	6	1260	10	950	3	1890
1020-0500	500	8	1890	12	1140		
1020-0600	600	9	1890	15	1425		
1020-0700	700	11	1890	17	1615	4	2520
1020-0800	800	12	2520	20	1900		
1020-0900	900	14	2520	22	2090	5	3150
1020-1000	1000	15	3150	25	2375		
1020-1100	1100	16	3150	27	2565		
1020-1200	1200	17	3150	30	2850	6	3780
1020-1300	1300	18	3780	32	3040		
1020-1400	1400	19	3780	35	3325	7	4410
1020-1500	1500	20	3780	37	3515		
1020-1600	1600	22	4410	40	3800		
1020-1700	1700	24	4410	42	3990	8	5040
1020-1800	1800	25	4410	45	4275		
1020-1900	1900	27	5040	47	4465		

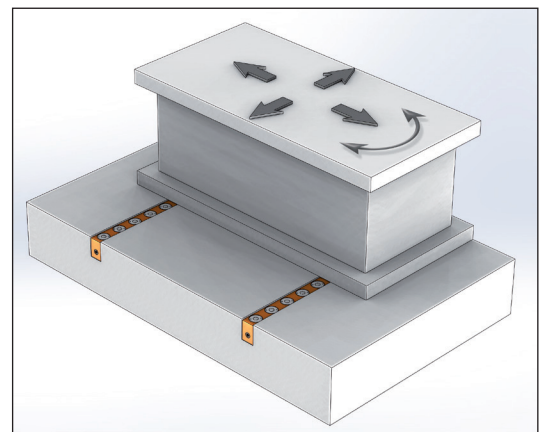

Model DB Hareket Yönü  
Model DB Movement Direction

**Ürün Nr. 1020 Hidrolik Kalıp Kaldırma Model DL-DB**

- Standart Sıcaklık : 60°
- Hidrolik Basınç : 250kgf/cm<sup>2</sup>

**Product Nr. 1020 Die Lifter Hydraulic Model DL-DB**

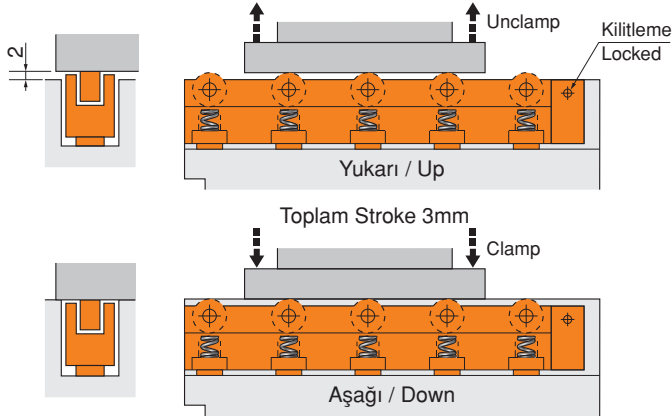

- Standard Temperature : 60°
- Hydraulic Pressure : 250kgf/cm<sup>2</sup>

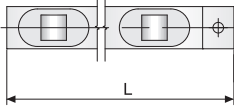
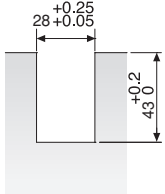

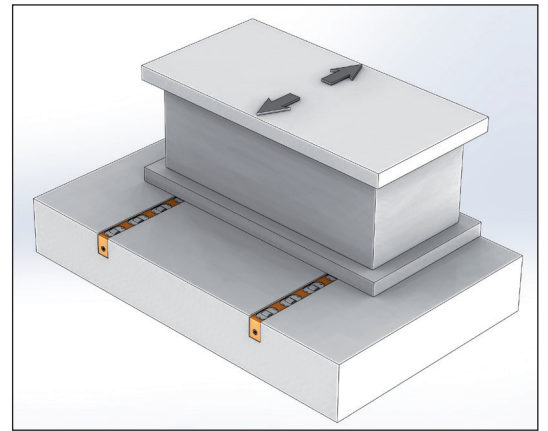
Dış Ölçüler Outline Dimensions	D□28 Serisi / Serial
	
Pleyt için işlem ölçüsü (U-Kanal) Processing Size for Plate (U-slot)	



Model DLS Hareket Yönü  
Model DLS Movement Direction

Referans Nr.	L	D□28					
		DLS28			DBS28		
		Rulo Roller (DLS)		Kapasite Capacity kg	Misket Ball (DBS)		Kapasite Capacity kg
1022-0200	200	3	4	500	5	5	315
1022-0300	300	5	6	750	7	7	441
1022-0400	400	6	7	875	10	10	630
1022-0500	500	8	9	1125	12	12	756
1022-0600	600	9	10	1250	15	15	945
1022-0700	700	11	12	1500	17	17	1071
1022-0800	800	12	13	1625	20	20	1260
1022-0900	900	14	15	1875	22	22	1386
1022-1000	1000	15	16	2000	25	25	1575
1022-1100	1100	16	17	2125	27	27	1701
1022-1200	1200	17	18	2250	30	30	1890
1022-1300	1300	18	19	2375	32	32	2016
1022-1400	1400	19	20	2500	35	35	2205
1022-1500	1500	20	21	2625	37	37	2331
1022-1600	1600	22	23	2875	40	40	2520
1022-1700	1700	24	25	3125	42	42	2646
1022-1800	1800	25	26	3250	45	45	2835
1022-1900	1900	27	28	3500	47	47	2961

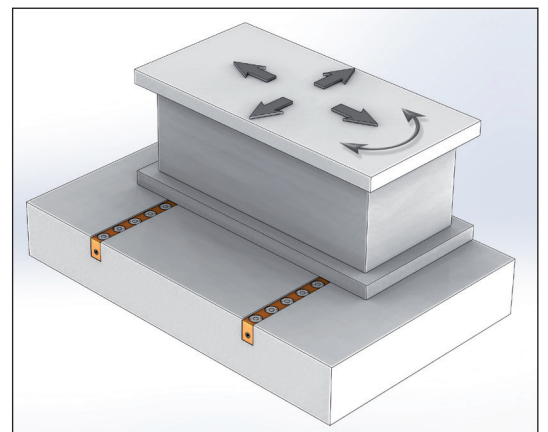

Model DBS Hareket Yönü  
Model DBS Movement Direction

Ürün Nr. 1022 Yaylı Kalıp Kaldırma Model DLS-DBS  
• Standart Sıcaklık : 60°

Product Nr. 1022 Die Lifter Spring Model DLS-DBS  
• Standard Temperature : 60°



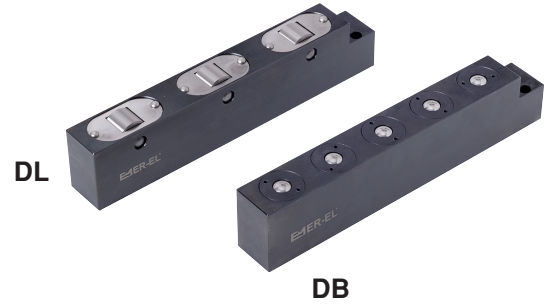
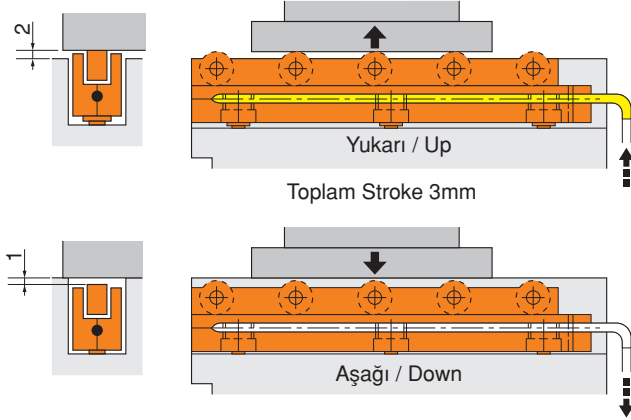

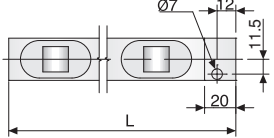
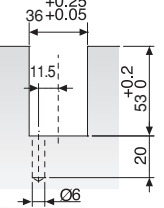
Dış Ölçüler Outline Dimensions	<p>□36 Serisi / Serial</p> 
	<p>Pleyt için işlem ölçüsü (U-Kanal) Processing Size for Plate (U-slot)</p> 

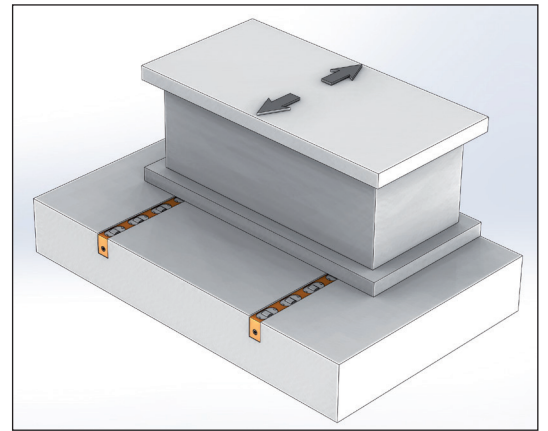

**Model DL Hareket Yönü**  
**Model DL Movement Direction**

Referans Nr.	L	□36				Hid. Silindir Hyd. cylinder	
		DL36		DB36		Piston	Kapasite Capacity kg
		Rulo Roller (DL)	Kapasite Capacity kg	Misket Ball (DB)	Kapasite Capacity kg		
1020-0200	200	3	1050	5	600	2	1700
1020-0300	300	5	1750	7	840		
1020-0400	400	6	1700	10	1200		
1020-0500	500	8	2600	12	1440	3	2600
1020-0600	600	9	2600	15	1800		
1020-0700	700	11	2600	17	2040		
1020-0800	800	12	2600	20	2400		
1020-0900	900	14	3500	22	2640	4	3500
1020-1000	1000	15	3500	25	3000		
1020-1100	1100	16	3500	27	3240		
1020-1200	1200	17	4400	30	3600	5	4400
1020-1300	1300	18	4400	32	3840		
1020-1400	1400	19	4400	35	4200		
1020-1500	1500	20	4400	37	4400		
1020-1600	1600	22	5300	40	4800	6	5300
1020-1700	1700	24	5300	42	5040		
1020-1800	1800	25	5300	45	5300		
1020-1900	1900	27	5300	47	5300		

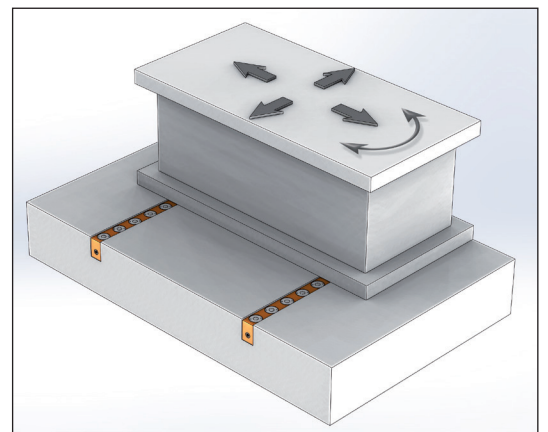

**Model DB Hareket Yönü**  
**Model DB Movement Direction**

**Ürün Nr. 1020 Hidrolik Kalıp Kaldırma Model DL-DB**

- Standart Sıcaklık : 60°
- Hidrolik Basınç : 250kgf/cm<sup>2</sup>

**Product Nr. 1020 Die Lifter Hydraulic Model DL-DB**

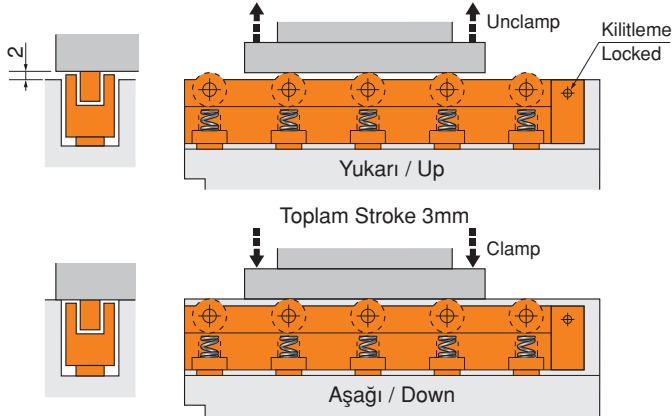

- Standard Temperature : 60°
- Hydraulic Pressure : 250kgf/cm<sup>2</sup>

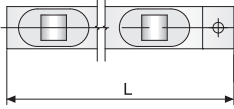
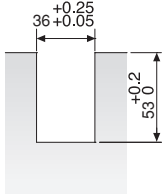

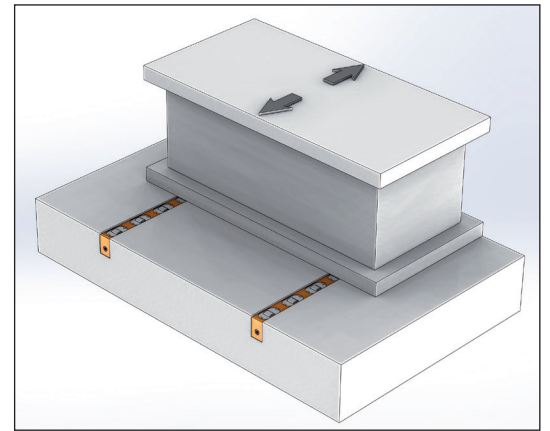
Dış Ölçüler Outline Dimensions	D□36 Serisi / Serial
	
Pleyt için işlem ölçüsü (U-Kanal) Processing Size for Plate (U-slot)	



Model DLS Hareket Yönü  
Model DLS Movement Direction

Referans Nr.	L	D□36					
		DLS36			DBS36		
		Rulo Roller (DLS)		Kapasite Capacity kg	Misket Ball (DBS)		Kapasite Capacity kg
1022-0200	200	3	3	600	5	5	500
1022-0300	300	5	5	1000	7	7	700
1022-0400	400	6	6	1200	10	10	1000
1022-0500	500	8	8	1600	12	12	1200
1022-0600	600	9	9	1800	15	15	1500
1022-0700	700	11	11	2200	17	17	1700
1022-0800	800	12	12	2400	20	20	2000
1022-0900	900	14	14	2800	22	22	2200
1022-1000	1000	15	15	3000	25	25	2500
1022-1100	1100	16	16	3200	27	27	2700
1022-1200	1200	17	17	3400	30	30	3000
1022-1300	1300	18	18	3600	32	32	3200
1022-1400	1400	19	19	3800	35	35	3500
1022-1500	1500	20	20	4000	37	37	3700
1022-1600	1600	22	22	4400	40	40	4000
1022-1700	1700	24	24	4800	42	42	4200
1022-1800	1800	25	25	5000	45	45	4500
1022-1900	1900	27	27	5400	47	47	4700

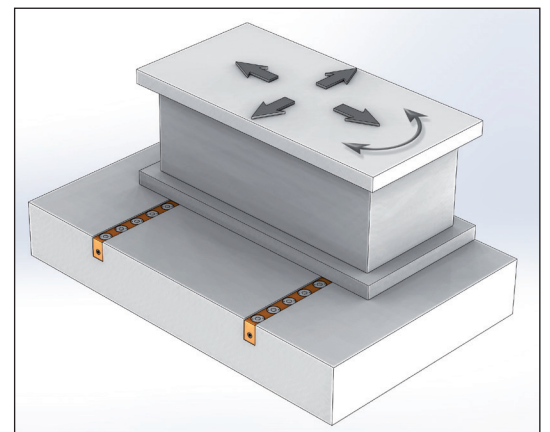

Model DBS Hareket Yönü  
Model DBS Movement Direction

Ürün Nr. 1022 Yaylı Kalıp Kaldırma Model DLS-DBS  
• Standart Sıcaklık : 60°

Product Nr. 1022 Die Lifter Spring Model DLS-DBS  
• Standard Temperature : 60°

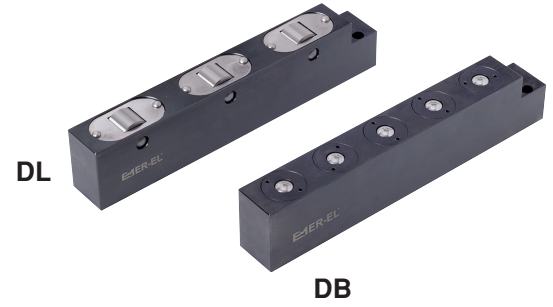
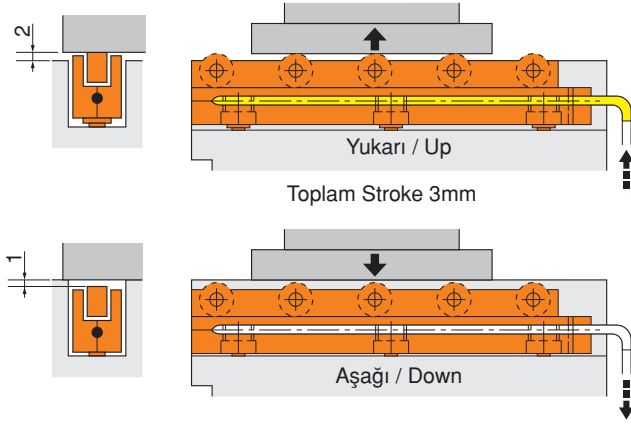

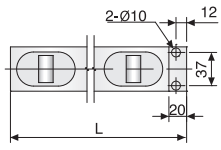
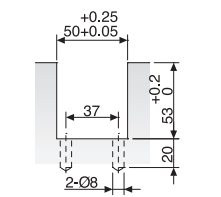
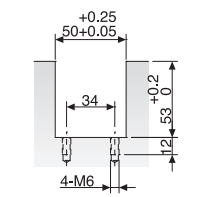
Dış Ölçüler Outline Dimensions	D□50 Serisi / Serial DL50-2100'den önce	D□50 Serisi / Serial DL50-2100'den sonra
		
Pleyt için işlem ölçüsü (U-Kanal) Processing Size for Plate (U-slot)		

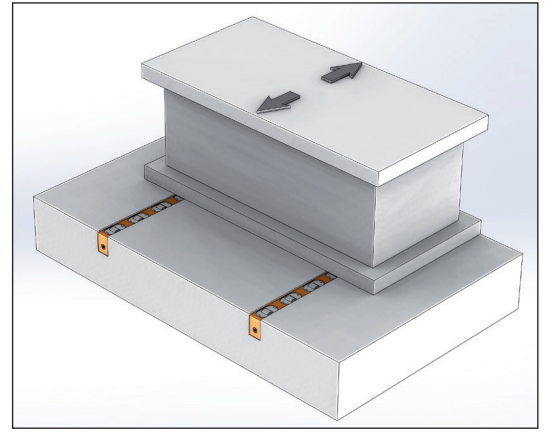

**Model DL Hareket Yönü**  
**Model DL Movement Direction**

Referans Nr.	L	D□50				Hid. Silindir Hyd. cylinder	
		DL50		DB50		Piston	Kapasite Capacity kg
		Rulo Roller (DL)	Kapasite Capacity kg	Misket Ball (DB)	Kapasite Capacity kg		
1020-0200	200	2	1000	4	640	2	2200
1020-0300	300	3	1500	6	960		
1020-0400	400	4	2000	9	1440	3	3300
1020-0500	500	5	2500	11	1760		
1020-0600	600	6	3000	13	2080		
1020-0700	700	7	3300	16	2560	4	4400
1020-0800	800	8	3300	18	2880		
1020-0900	900	9	4400	20	3200	5	5500
1020-1000	1000	10	4400	23	3680		
1020-1100	1100	11	4400	25	4000		
1020-1200	1200	12	5500	27	4320	6	6600
1020-1300	1300	13	5500	29	4640		
1020-1400	1400	14	5500	31	4960	7	7700
1020-1500	1500	15	5500	33	5280		
1020-1600	1600	16	6500	35	5600		
1020-1700	1700	17	6500	38	6080	8	8800
1020-1800	1800	18	6500	40	6400		
1020-1900	1900	19	6500	42	6720	8	8800
1020-2000	2000	20	7700	44	7040		
1020-2100	2100	21	7700	46	7360		
1020-2200	2200	22	7700	48	7680	8	8800
1020-2300	2300	23	7700	50	7700		
1020-2400	2400	24	8800	52	8320	8	8800
1020-2500	2500	25	8800	54	8640		

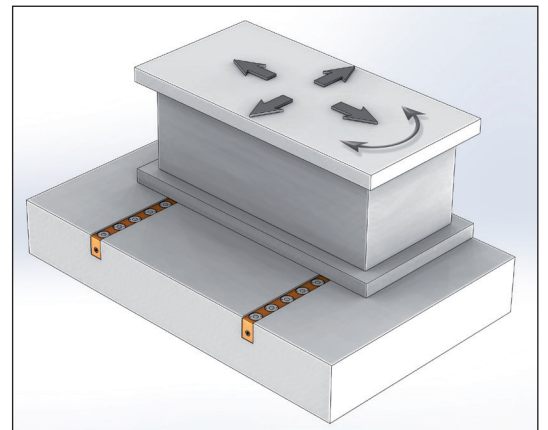

**Model DB Hareket Yönü**  
**Model DB Movement Direction**

**Ürün Nr. 1020 Hidrolik Kalıp Kaldırma Model DL-DB**

- Standart Sıcaklık : 60°
- Hidrolik Basınç : 250kgf/cm<sup>2</sup>

**Product Nr. 1020 Die Lifter Hydraulic Model DL-DB**

- Standard Temperature : 60°
- Hydraulic Pressure : 250kgf/cm<sup>2</sup>



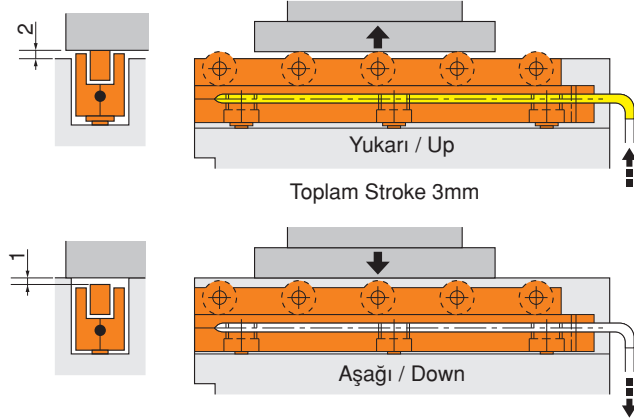

DL

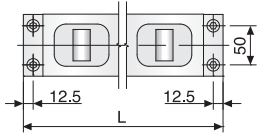
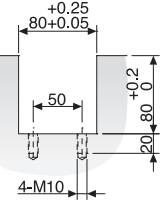

	DL80 Serisi / Serial
Dış Ölçüler Outline Dimensions	
Pleyt için işlem ölçüsü (U-Kanal) Processing Size for Plate (U-slot)	

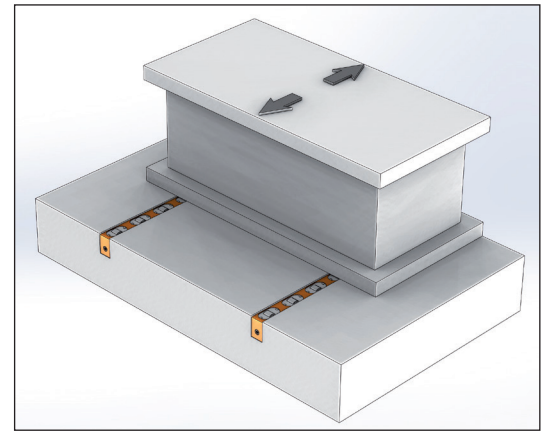

Model DL Hareket Yönü  
Model DL Movement Direction

Referans Nr.	L	DL80			
		DL80		Hid. Silindir Hyd. cylinder	
		Rulo Roller (DL)	Kapasite Capacity kg	Piston	Kapasite Capacity kg
1020-0200	200	-	-	-	-
1020-0300	300	-	-	-	-
1020-0400	400	-	-	-	-
1020-0500	500	5	3250	2	5600
1020-0600	600	6	3900		
1020-0700	700	7	4550	3	8400
1020-0800	800	8	5200		
1020-0900	900	9	5850		
1020-1000	1000	10	6500	4	11200
1020-1100	1100	11	7150		
1020-1200	1200	12	7800		
1020-1300	1300	13	8450		
1020-1400	1400	14	9100	5	14000
1020-1500	1500	15	9750		
1020-1600	1600	16	10400		
1020-1700	1700	17	11050	6	16800
1020-1800	1800	18	11700		
1020-1900	1900	19	12350		
1020-2000	2000	20	13000		
1020-2100	2100	21	13650	7	19600
1020-2200	2200	22	14300		
1020-2300	2300	23	14950		
1020-2400	2400	24	15600		
1020-2500	2500	25	16250		

**Ürün Nr. 1020 Hidrolik Kalıp Kaldırma Model DL**

- Standart Sıcaklık : 60°
- Hidrolik Basınç : 250kgf/cm<sup>2</sup>

**Product Nr. 1020 Die Lifter Hydraulic Model DL**

- Standard Temperature : 60°
- Hydraulic Pressure : 250kgf/cm<sup>2</sup>

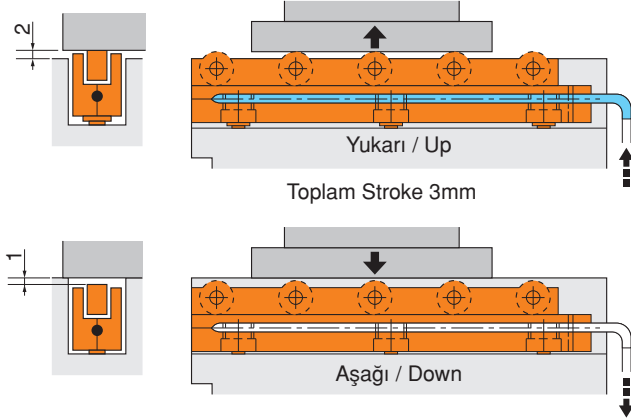

**NEW**

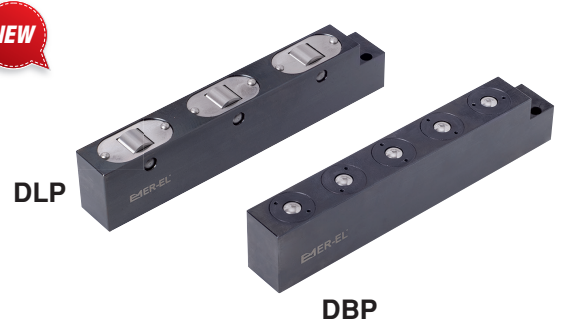

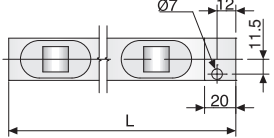
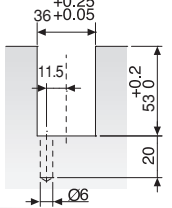
D□□36 Serisi / Serial	
Dış Ölçüler Outline Dimensions	
Pleyt için işlem ölçüsü (U-Kanal) Processing Size for Plate (U-slot)	

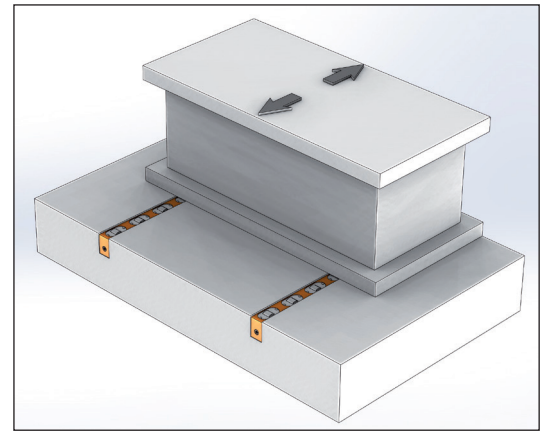

**Model DLP Hareket Yönü**  
**Model DLP Movement Direction**

Referans Nr.	L	D□□36						
		DLP36	DBP36	Pnömatik Silindir Pneumatic cylinder				Piston
		Rulo Roller (DLP)	Misket Ball (DBP)	6 Bar Kapasite	8 Bar Kapasite	10 Bar Kapasite	12 Bar Kapasite	
1023-0200	200	3	5	200	260	320	400	4
1023-0300	300	5	7	300	390	480	600	6
1023-0400	400	6	10	400	520	640	800	8
1023-0500	500	8	12	550	715	880	1100	11
1023-0600	600	9	15	650	845	1040	1300	13
1023-0700	700	11	17	750	975	1200	1500	15
1023-0800	800	12	20	900	1170	1440	1800	18
1023-0900	900	14	22	1000	1300	1600	2000	20
1023-1000	1000	15	25	1100	1430	1760	2200	22
1023-1100	1100	16	27	1250	1625	2000	2500	25
1023-1200	1200	17	30	1350	1755	2160	2700	27
1023-1300	1300	18	32	1450	1885	2320	2900	29
1023-1400	1400	19	35	1550	2015	2480	3100	31
1023-1500	1500	20	37	1700	2210	2720	3400	34
1023-1600	1600	22	40	1800	2340	2880	3600	36
1023-1700	1700	24	42	1900	2470	3040	3800	38
1023-1800	1800	25	45	2050	2665	3280	4100	41
1023-1900	1900	27	47	2150	2795	3440	4300	43

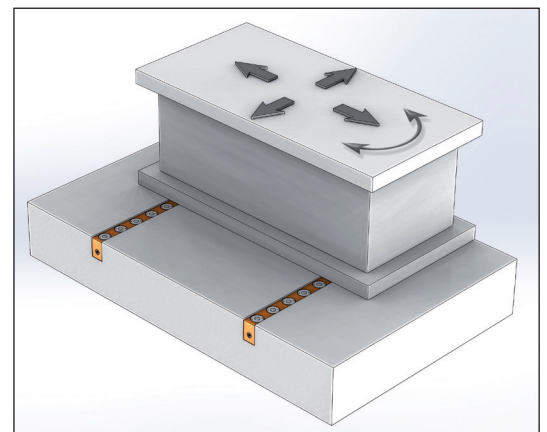

**Model DBP Hareket Yönü**  
**Model DBP Movement Direction**

Ürün Nr. 1023 Hidrolik Kalıp Kaldırma Model DLP-DBP  
• Standart Sıcaklık : 60°

Product Nr. 1023 Die Lifter Hydraulic Model DLP-DBP  
• Standard Temperature : 60°

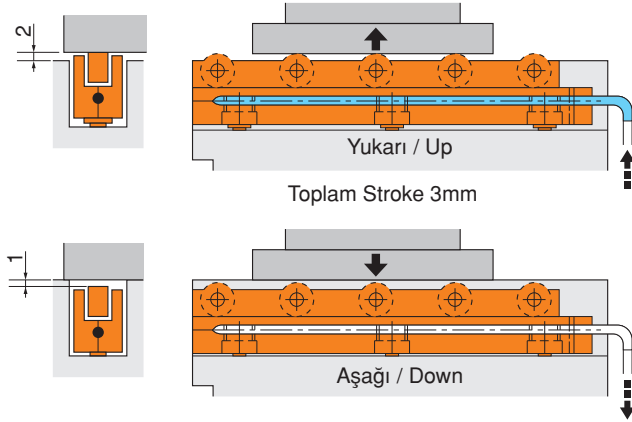

NEW

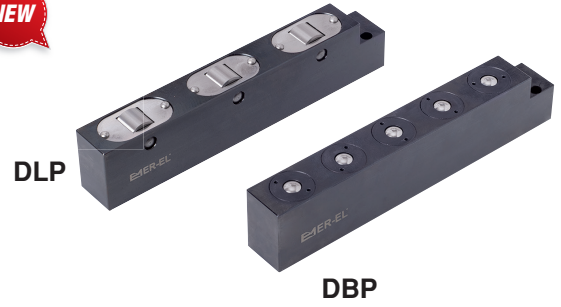

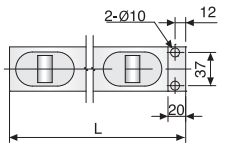
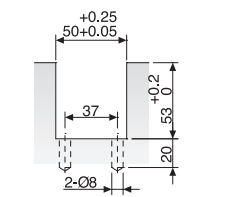
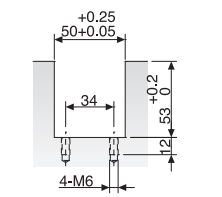
Dış Ölçüler Outline Dimensions	D□□50 Serisi / Serial DL50-2100'den önce	D□□50 Serisi / Serial DL50-2100'den sonra
		
Pleyt için işlem ölçüsü (U-Kanal) Processing Size for Plate (U-slot)		

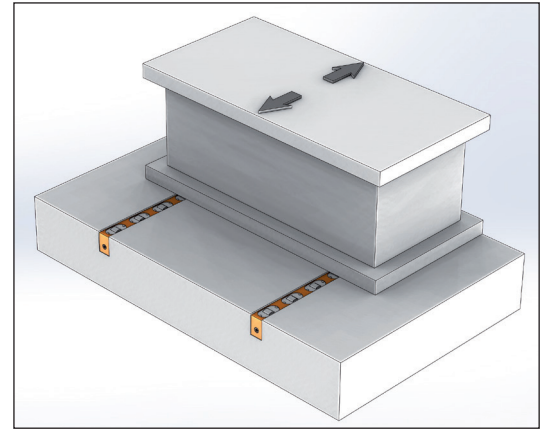

Model DLP Hareket Yönü  
Model DLP Movement Direction

Referans Nr.	L	D□□50						
		Pnömatik Silindir Pneumatic cylinder		Piston				
		Rulo Roller (DLP)	Misket Ball (DBP)	6 Bar Kapasite	8 Bar Kapasite	10 Bar Kapasite	12 Bar Kapasite	Piston
1023-0200	200	2	4	285	375	480	570	3
1023-0300	300	3	6	380	500	640	760	4
1023-0400	400	4	9	570	750	960	1140	6
1023-0500	500	5	11	665	875	1120	1330	7
1023-0600	600	6	13	855	1125	1440	1710	9
1023-0700	700	7	16	1045	1375	1760	2090	11
1023-0800	800	8	18	1140	1500	1920	2280	12
1023-0900	900	9	20	1330	1750	2240	2660	14
1023-1000	1000	10	23	1520	2000	2560	3040	16
1023-1100	1100	11	25	1710	2250	2880	3420	18
1023-1200	1200	12	27	1805	2375	3040	3610	19
1023-1300	1300	13	29	1995	2625	3360	3990	21
1023-1400	1400	14	31	2090	2750	3520	4180	22
1023-1500	1500	15	33	2280	3000	3840	4560	24
1023-1600	1600	16	35	2470	3250	4160	4940	26
1023-1700	1700	17	38	2565	3375	4320	5130	27
1023-1800	1800	18	40	2755	3625	4640	5510	29
1023-1900	1900	19	42	2945	3875	4960	5890	31
1023-2000	2000	20	44	3135	4125	5280	6270	33
1023-2100	2100	21	46	3230	4250	5440	6460	34
1023-2200	2200	22	48	3420	4500	5760	6840	36
1023-2300	2300	23	50	3610	4750	6080	7220	38
1023-2400	2400	24	52	3705	4875	6240	7410	39
1023-2500	2500	25	54	3895	5125	6560	7790	41

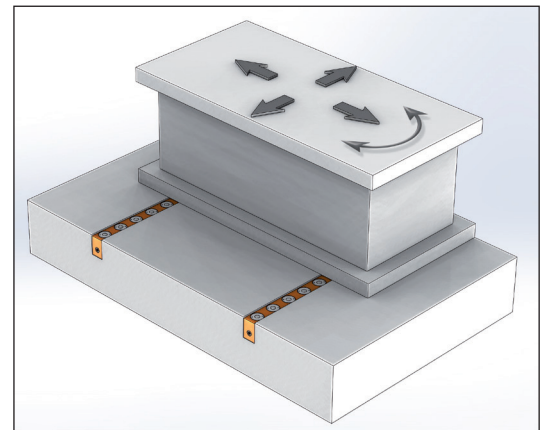

Model DBP Hareket Yönü  
Model DBP Movement Direction

Ürün Nr. 1023 Hidrolik Kalıp Kaldırma Model DLP-DBP  
• Standart Sıcaklık : 60°

Product Nr. 1023 Die Lifter Hydraulic Model DLP-DBP  
• Standard Temperature : 60°



Referans Nr.	d	Kapasite kg	e	t	l	d1	
1022-DLSD0050	20	50	25	3.5	31	10	45
1022-DLSD0080	24	80	30	4	39	14	75
1022-DLSD0125	30	125	35	5	45	20	140
1022-DLSD0200	40	200	50	6	54	30	375
1022-DLSDD050	20	50	-	-	30	10	35
1022-DLSDD080	24	80	-	-	38	14	70
1022-DLSDD125	30	125	-	-	44	20	130
1022-DLSDD200	40	200	-	-	53	30	240



DLSD



DLSDD

Ürün Nr. 1022 Yaylı Silindir Kalıp Kaldırma Model DLS  
Product Nr. 1022 Die Lifter Spring Cylinder Model DLS

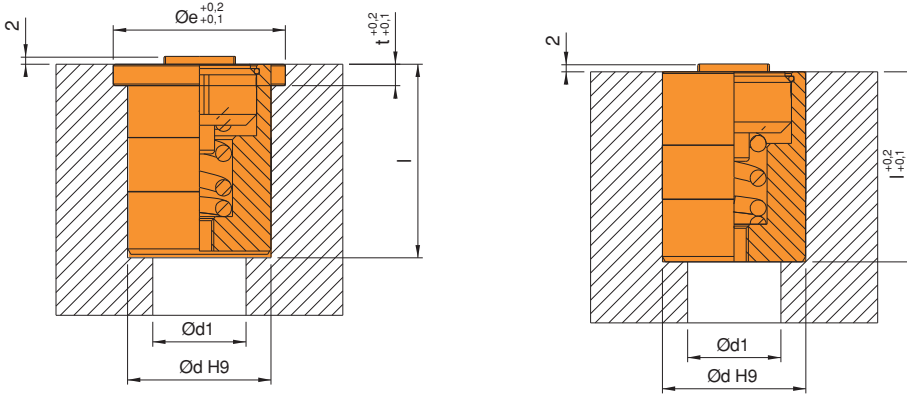

## Yaylı Silindir Kalıp Kaldırma Model DBS

Die Lifter Spring Cylinder Model DBS

Referans Nr.	d	Kapasite kg	e	t	l	d1	
1022-DBSD0025	20	25	25	3.5	31	10	45
1022-DBSD0040	24	40	30	4	39	14	85
1022-DBSD0063	30	63	35	5	45	20	150
1022-DBSD0100	40	100	50	6	54	30	350
1022-DBSDD025	20	25	-	-	30	10	40
1022-DBSDD040	24	40	-	-	38	14	80
1022-DBSDD063	30	63	-	-	44	20	140
1022-DBSDD100	40	100	-	-	53	30	325



DBSD



DBSDD

Ürün Nr. 1022 Yaylı Silindir Kalıp Kaldırma Model DBS  
Product Nr. 1022 Die Lifter Spring Cylinder Model DBS

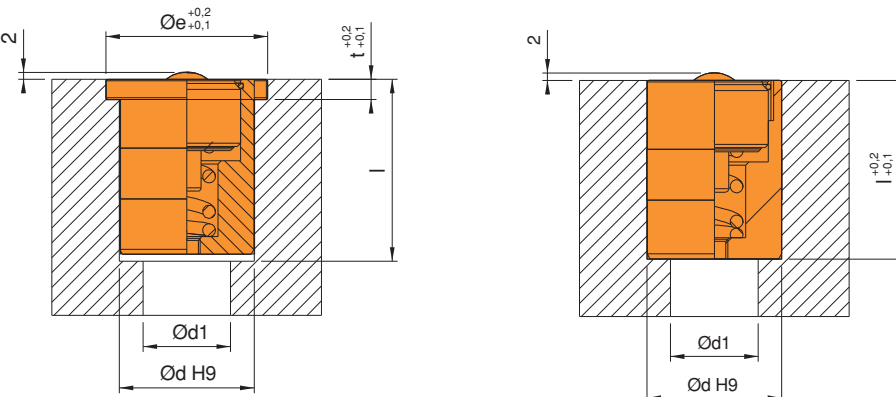

# KALIP YÜKLEME TABLASI

## MOLD TRANSPORT TRAY

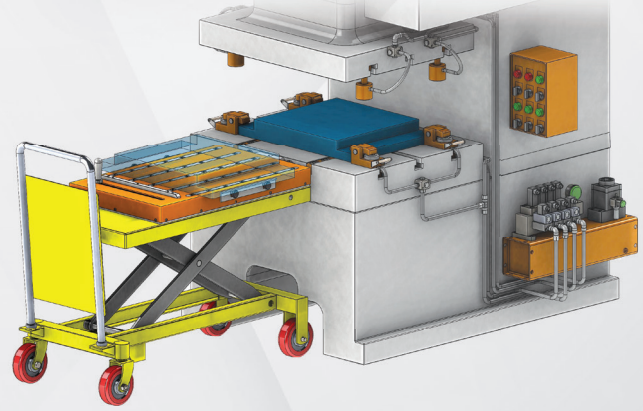

### Kalıp Yükleme Tablası Uygulamaları / Mold Transport Tray Applications



Kalıp Yükleme Tablası  
Mold Transport Tray



Kalıp Yükleme Tablası (Arabalı)  
Mold Transport Tray (Trolley)



Kalıp Yükleme Tablası (Elektrikli Forklift)  
Mold Transport Tray (Electric Forklift)



Kalıp Yükleme Tablası (Forklift)  
Mold Transport Tray (Forklift)

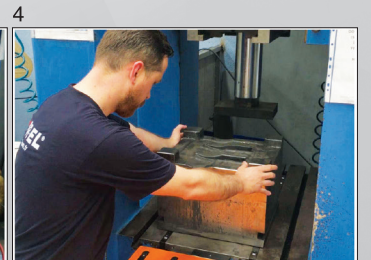
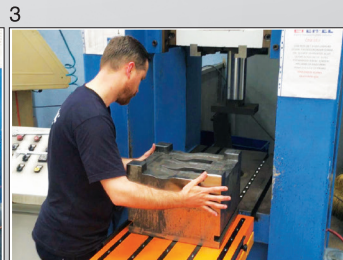

Referans Nr.	A	L2	H	L	Kapasite Capacity
1024-500670	500	670	71	818	1 Ton / Tone

### Ürün Nr. 1024 Kalıp Yükleme Tablası

- Ağırlığı 1 tona kadar olan kalıpları, pres tablasına veya raflara yerleştirmek için yükleme esnasında hareket ettirmek istendiğinde, yüzey temasını azaltır. Böylece rahatlıkla, çok fazla güce ihtiyaç duymadan hızlı ve pratik şekilde kalıbı yükleme olanağı sağlamaktadır.
- Kalıp arabasına veya forklift araçlarına montaj özelliği ile birlikte kolaylıkla sabitlenip kullanılabilir.

### Product Nr. 1024 Mold Transport Tray

- Molds up to 1 ton weight, it reduces surface contact when it is desired to be moved during loading to be placed on the press table or shelves. Thus, it provides the possibility of loading the mold easily and quickly without the need for much power.
- It can be mounted on mold cart or forklifts and can be easily used.

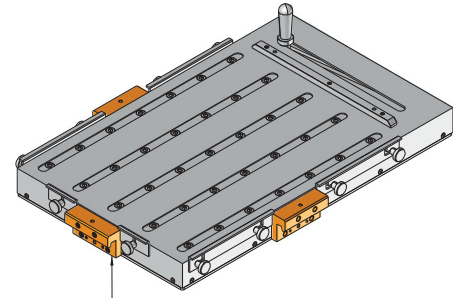
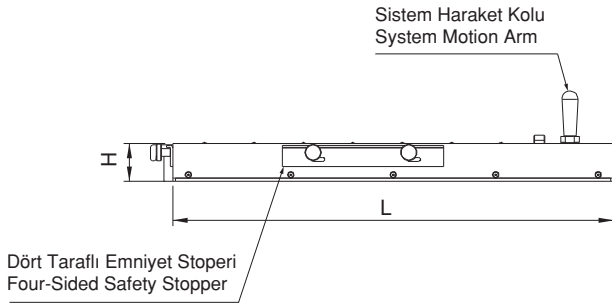

Taşıma Arabası ve Benzer Ekipmanlar İçin Montaj Delikleri  
Mounting Holes For Transport Tray and Similar Equipment

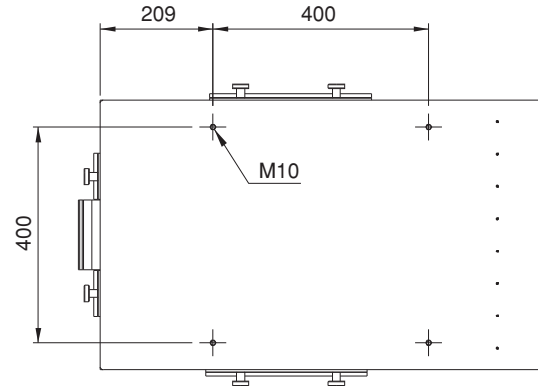
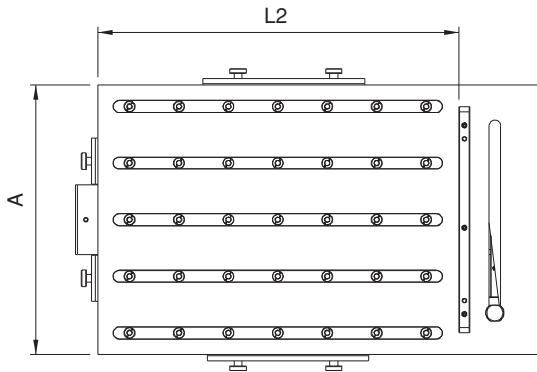

### Kalıp Yükleme Tablası Uygulamaları / Mold Transport Tray Applications



Kalıp Yükleme Tablası  
Mold Transport Tray



Kalıp Yükleme Tablası (Arabalı)  
Mold Transport Tray (Trolley)



Kalıp Yükleme Tablası (Elektrikli Forklift)  
Mold Transport Tray (Electric Forklift)



Kalıp Yükleme Tablası (Forklift)  
Mold Transport Tray (Forklift)



Referans Nr.	A	L2	H (min. - max.)	L	L1	Kapasite Capacity
1024-500671	500	670	480 - 1050	818	1015	1 Ton / Tonne

### Ürün Nr. 1024 Kalıp Yükleme Tablası (Arabalı)

- Ağırlığı 1 tona kadar olan kalıpları, pres tablasına veya raflara yerleştirmek için yükleme esnasında hareket ettirilmek istendiğinde, yüzey temasını azaltır. Böylece rahatlıkla, çok fazla güce ihtiyaç duymadan hızlı ve pratik şekilde kalıbı yükleme olanağı sağlamaktadır.

### Product Nr. 1024 Mold Transport Tray (Trolley)

- Molds up to 1 ton weight, it reduces surface contact when it is desired to be moved during loading to be placed on the press table or shelves. Thus, it provides the possibility of loading the mold easily and quickly without the need for much power.

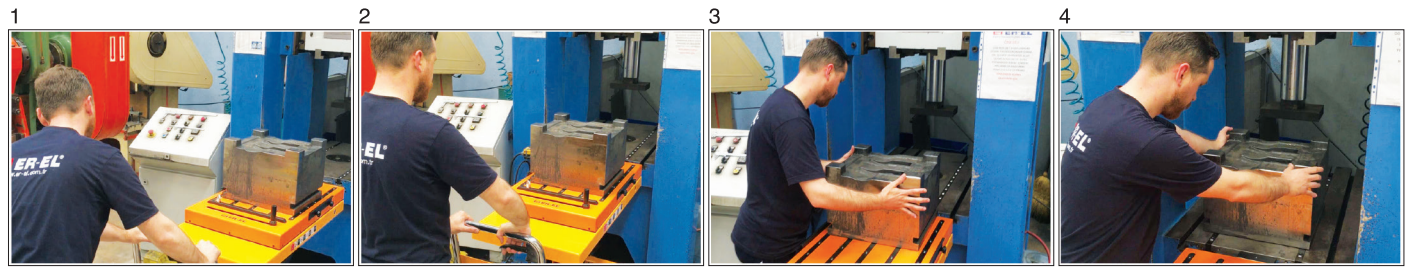
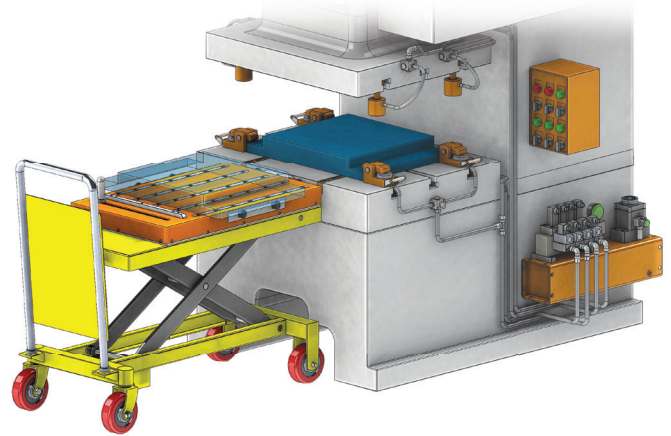
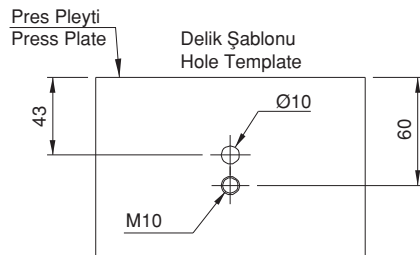
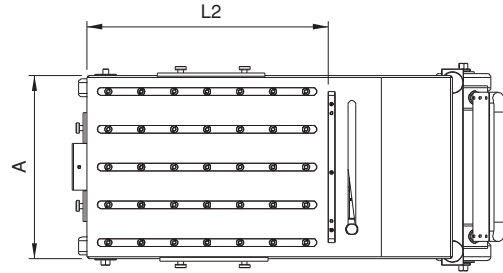
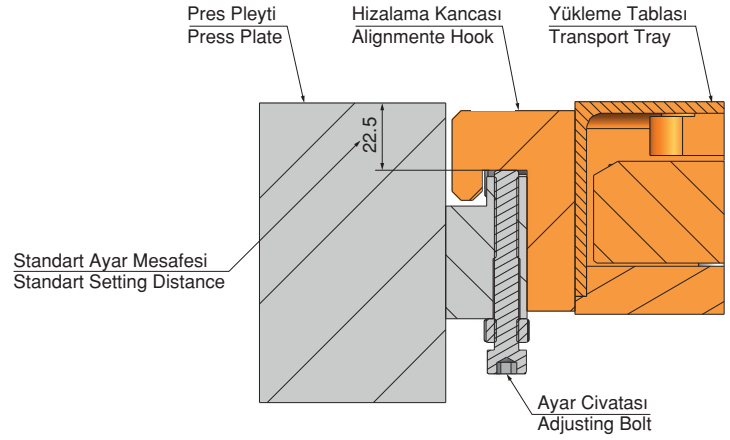
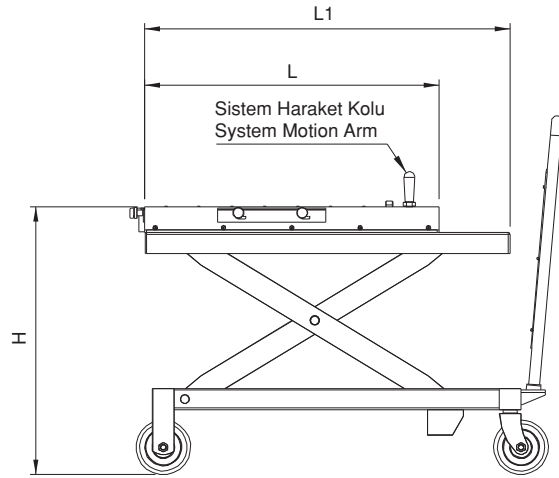

## Model RC - RD - RE/RF

Model Seçimi / Model Selection

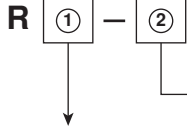

Model	Saklama Metodu / Storage Method	Tanımlama / Specification
C	Demonte / Dismantling	580 mm
D	Asmalı / Hanging	760 mm
E	Katlamalı (kısa) / Folding (short)	880 mm
F	Katlamalı (uzun) / Folding (long)	990 mm

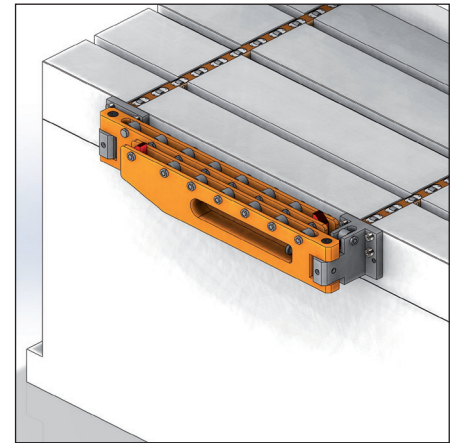
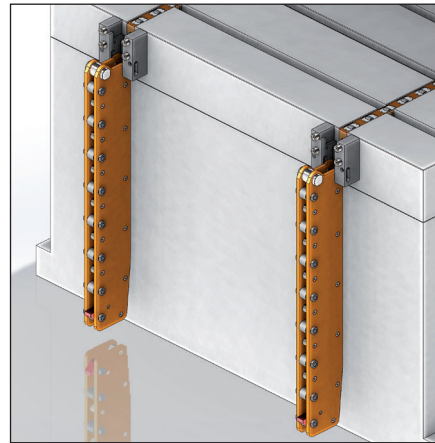
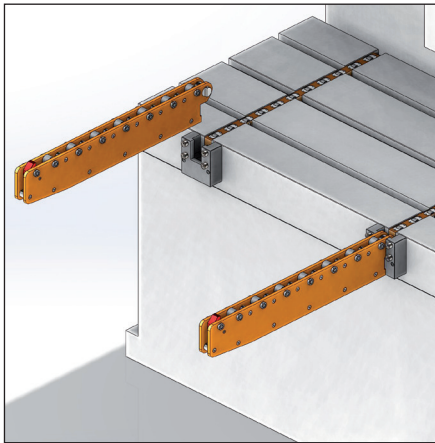
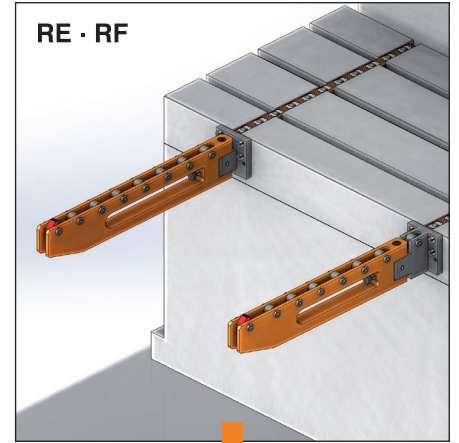
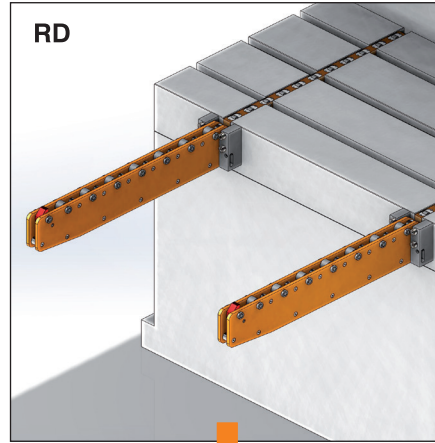
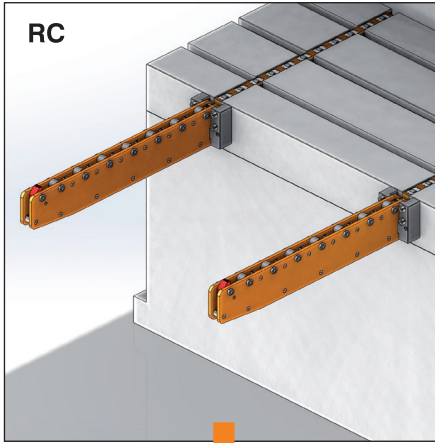
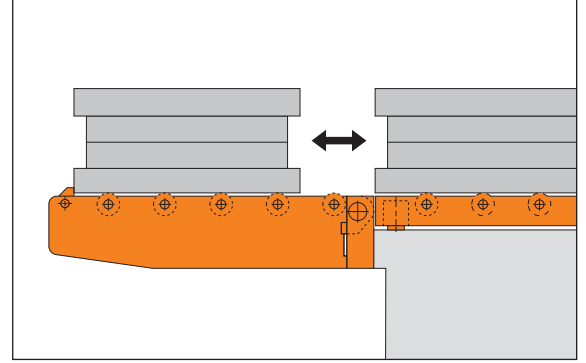

Referans Nr.	Destek Modeli Model of Support	İhtiyaç Duyulan Kalıp uzunluğu Length Needed of the Die L(mm)	Max. Kapasite Max. Capacity (kgf)	Top. Uzunluk Total Length A (mm)	Destek ölçüleri Size of Support			Kurulum için Delik Şekilleri Hole Pattern For Installation	Silindir sayısı Number of Roller
					D	B	H		
1025-RC580	RC-12	500	800	550	48	115	118	A Tipi / A Type	5
1025-RC760	RC-12	700	600	750	48	115	118	A Tipi / A Type	7
1025-RC880	RC-16	800	800	850	48	115	158	B Tipi / B Type	8
1025-RC990	RC-20	900	900	950	48	115	188	B Tipi / B Type	9
1027-RC05125	RC-14H	500	1250	550	55	130	138	C Tipi / C Type	7
1027-RC05160	RC-16H	500	1600	550	55	130	158	C Tipi / C Type	7
1027-RC05200	RC-18H	500	2000	550	55	130	178	C Tipi / C Type	7
1027-RC07125	RC-14H	700	1250	750	55	130	138	C Tipi / C Type	9
1027-RC07160	RC-16H	700	1600	750	55	130	158	C Tipi / C Type	9
1027-RC07200	RC-18H	700	2000	750	55	130	178	C Tipi / C Type	9
1027-RC08125	RC-16H	800	1250	850	55	130	158	C Tipi / C Type	10
1027-RC08160	RC-18H	800	1600	850	55	130	178	C Tipi / C Type	10
1027-RC08200	RC-20H	800	2000	850	55	130	188	C Tipi / C Type	10
1027-RC09160	RC-22H	900	1600	950	55	130	218	C Tipi / C Type	11

Ürün Nr. 1027 Kalıp Kaydırma Kolu Model RC

Product Nr. 1027 Die Arm Model RC

### Model RC (Demonte / Dismantling)

- RC modelinde, kol ve destek ayrı olarak kullanılabilir.
- The arm itself and the support in Model RC can be used separately.

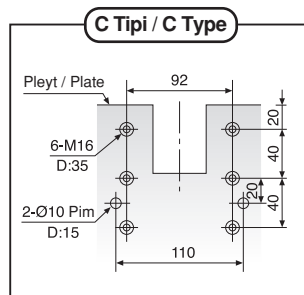
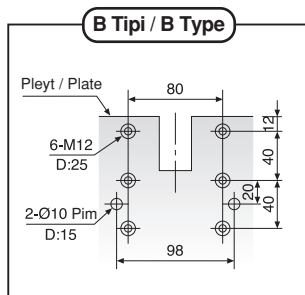
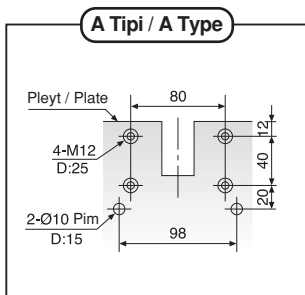
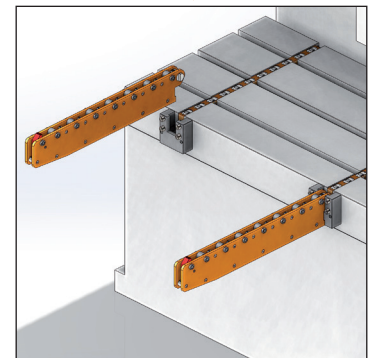
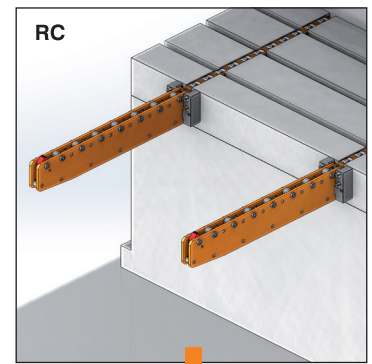
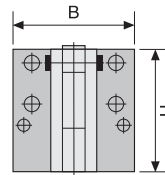
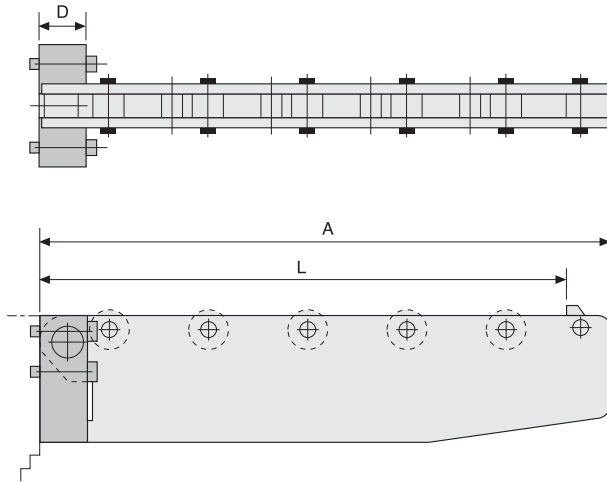
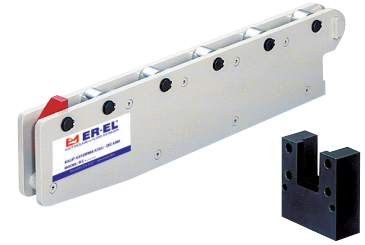



Referans Nr.	İhtiyaç Duyulan Kalıp uzunluğu Length Needed of the Die L(mm)	Max. Kapasite Max. Capacity (kgf)	Top. Uzunluk Total Length A (mm)	Asma Ölçüleri Size of Hanging		Destek Ölçüleri Size of Support			Kurulum için Delik Şekilleri Hole Pattern For Installation	Silindir sayısı Number of Roller
				X	Y	D	B	H		
1030-RD580	500	800	550	140	620	52	115	118	A Tipi / A Type	5
1030-RD760	700	600	750	140	820	52	115	118	A Tipi / A Type	7
1030-RD880	800	800	850	180	960	52	115	158	B Tipi / B Type	8
1030-RD990	900	900	950	220	1100	52	115	188	B Tipi / B Type	9
1030-RD05125	500	1250	550	170	645	62	130	138	C Tipi / C Type	7
1030-RD05160	500	1600	550	190	670	62	130	158	C Tipi / C Type	7
1030-RD05200	500	2000	550	210	675	62	130	178	C Tipi / C Type	7
1030-RD07125	700	1250	750	170	840	62	130	138	C Tipi / C Type	9
1030-RD07160	700	1600	750	190	865	62	130	158	C Tipi / C Type	9
1030-RD07200	700	2000	750	210	890	62	130	178	C Tipi / C Type	9
1030-RD08125	800	1250	850	190	960	62	130	158	C Tipi / C Type	10
1030-RD08160	800	1600	850	210	985	62	130	178	C Tipi / C Type	10
1030-RD08200	800	2000	850	220	995	62	130	188	C Tipi / C Type	10
1030-RD09160	900	1600	950	250	1130	62	130	218	C Tipi / C Type	11

Ürün Nr. 1030 Kalıp Kaydırma Kolu Model RD

Product Nr. 1030 Die Arm Model RD

### Model RD (Asmalı / Hanging)

- RD modelinin asma uzunluğu (Y) zemin ve plaka arasındaki yükseklik farkından daha düşük olmalıdır.
- The hanging length (Y) of Model RD should be less than the height between the plate and the ground

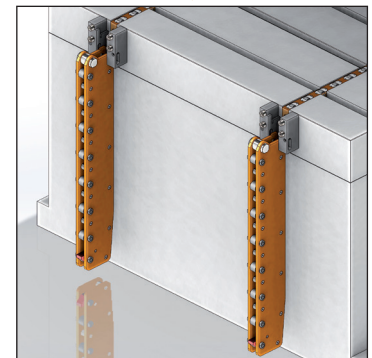
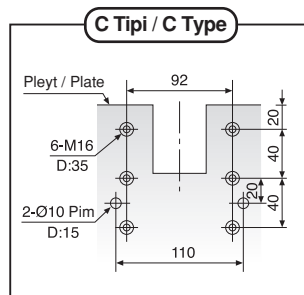
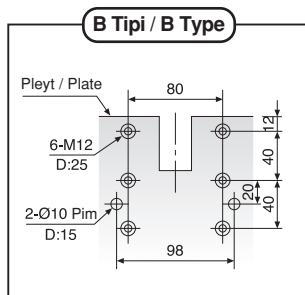
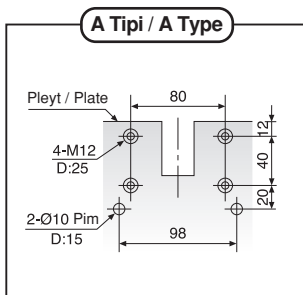
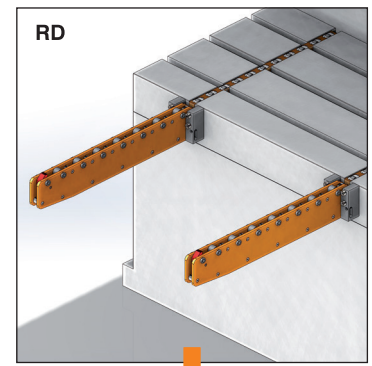
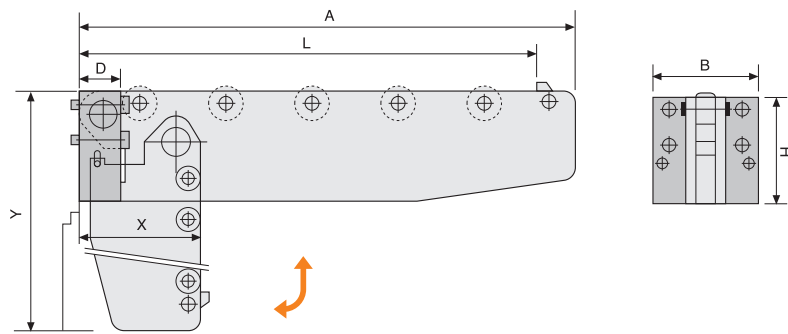

Referans Nr.	İhtiyaç Duyulan Kalıp uzunluğu Length Needed of the Die L (mm)	Max. Kapasite Max. Capacity (kgf)	Top. Uzunluk Total Length A (mm)	Kurulum için Gerekli Minimum Mesafe Min. Distance for Installation C (mm)	Katlı Haliyle Ölçüler Size of Fold Down		Destek ölçüleri Size of Support		Silindir Sayısı Number of Roller	M	N	Kurulum için Delik Şekilleri Hole Pattern For Installation
					X	Y	B	H				
1033-RERF580	500	800	550	525	90	150	115	118	5	57	120	A Tipi / A Type
1033-RERF760	700	600	750	725	90	150	115	118	7	57	120	A Tipi / A Type
1033-RERF880	800	800	850	825	90	150	115	158	8	57	120	B Tipi / B Type
1033-RERF990	900	900	950	925	90	150	115	188	9	57	120	B Tipi / B Type

**Ürün Nr. 1033 Kalıp Kaydırma Kolu Model RE-RF**

- İş bittiğinde sağa veya sola katlanabilir.

**Product Nr. 1033 Die Arm Model RE-RF**

- Itself can be turned left or right for storage.

Referans Nr.	İhtiyaç Duyulan Kalıp uzunluğu Length Needed of the Die L (mm)	Max. Kapasite Max. Capacity (kgf)	Top. Uzunluk Total Length A (mm)	Kurulum için Gerekli Minimum Mesafe Min. Distance for Installation C (mm)	Katlı Haliyle Ölçüler Size of Fold Down		Destek ölçüleri Size of Support		Silindir Sayısı Number of Roller	M	N	Kurulum için Delik Şekilleri Hole Pattern For Installation
					X	Y	B	H				
1035-RERF05160	500	1600	550	525	105	170	130	158	7	74	140	C Tipi / C Type
1035-RERF05200	500	2000	550	525	105	170	130	178	7	74	140	C Tipi / C Type
1035-RERF07160	700	1600	750	725	105	170	130	158	9	74	140	C Tipi / C Type
1035-RERF07200	700	2000	750	725	105	170	130	178	9	74	140	C Tipi / C Type
1035-RERF08160	800	1600	850	825	105	170	130	178	10	74	140	C Tipi / C Type
1035-RERF08200	800	2000	850	825	105	170	130	188	10	74	140	C Tipi / C Type
1035-RERF09160	900	1600	950	925	105	170	130	218	11	74	140	C Tipi / C Type
1035-RERF09200	900	2000	950	925	105	170	130	248	11	74	140	C Tipi / C Type

**Ürün Nr. 1035 Kalıp Kaydırma Kolu Model RE-RF**

- İş bittiğinde sağa veya sola katlanabilir.
- RE ve RF Modellerinin kurulduğu mesafe (C) mesafesinden daha büyük olmalıdır.

**Product Nr. 1035 Die Arm Model RE-RF**

- Itself can be turned left or right for storage.
- The distance for installing the two arms of Model RE and RF should be more than the distance between the installations (C)

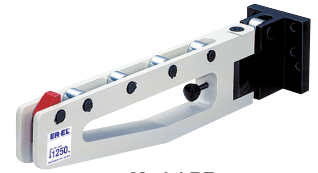
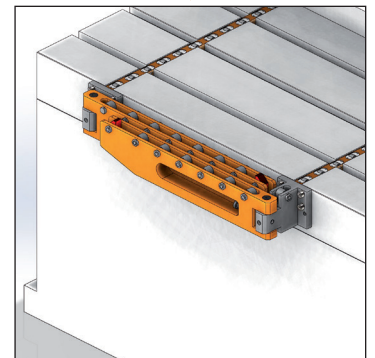
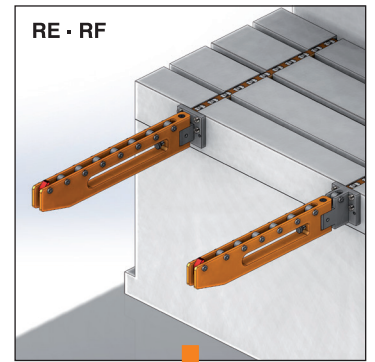
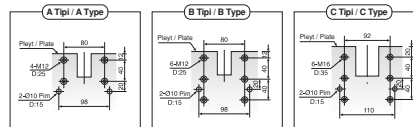
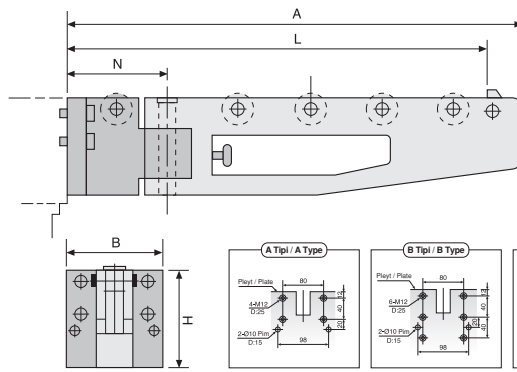
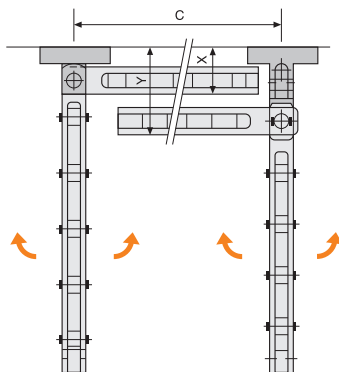
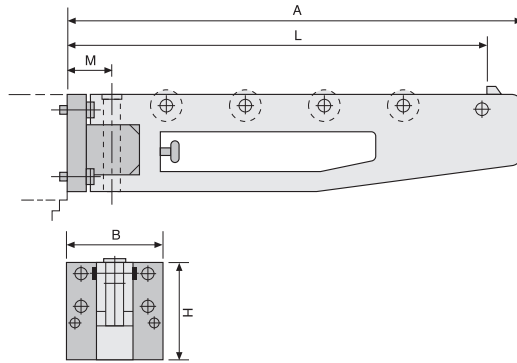
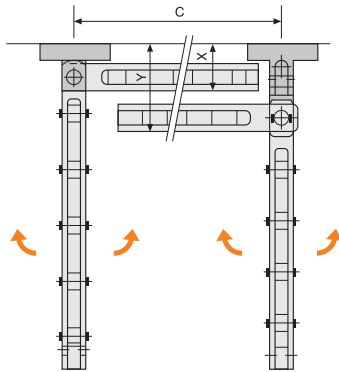
**Model RE**  
Katlamalı / Folding

**Model RF**  
Katlamalı / Folding

### Model RS (Destekli / Supporter)



Proje özel üretimdir.



Project is special produce.

### Model Seçimi / Model Selection

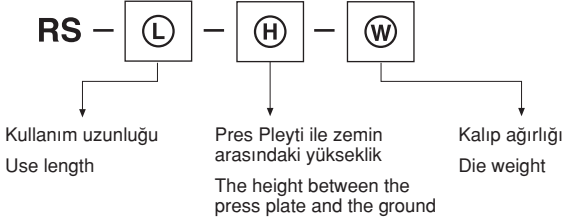

### Ürün Nr. 1037 Kalıp Kaydırma Kolu Model RS (Ağır Yük) Product Nr. 1037 Die Arm Model RS (Heavy Duty)

- Sipariş verirken yukarıdaki bilgileri bildirmeniz gerekmektedir.
- Delik işleminde (D) tipi destek ölçülerini kullanın.
- Please clearly indicate the above information while ordering.
- Adopt (D) type to install hole pattern.

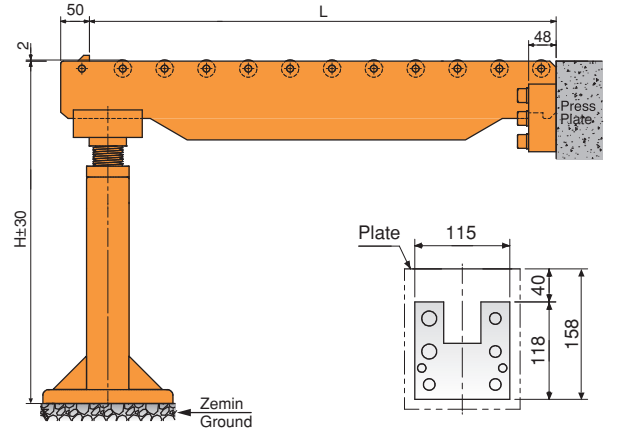

### RS MODEL DELİK DELME ŞABLONU RS MODEL HOLE PATTERN FOR INSTALLATION

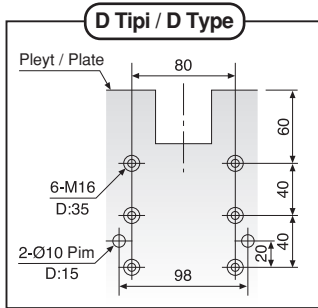

### Aksesuarlar Accessories

**Bağlayıcı Tüp**  
Tube Connector  
Referans Nr.  
1036-BT

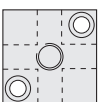

**Fır Döndü**  
Swivel  
Referans Nr.  
1036-FD



**Döner Eklem**  
Rotary Joint  
Referans Nr.  
1036-DE



**Pabuç Askısı**  
Clamp Bracket  
Referans Nr.  
1036-CACV



**Pabuç Askısı**  
Clamp Bracket  
Referans Nr.  
1036-CB



**Pompa Kabini**  
Pump Cabin  
Referans Nr.  
1036-PK





**Model RSM (Destekli / Supporter)**

**Not**  
Proje özel üretimdir.

**Note**  
Project is special produce.

**Model Seçimi / Model Selection**

RSM – (L) – (H) – (W)

Kullanım uzunluğu  
Use length

Pres Pleyti ile zemin  
arasındaki yükseklik  
The height between the  
press plate and the ground

Kalıp ağırlığı  
Die weight

**Ürün Nr. 1038 Motorlu Kalıp Kaydırma Kolu Model RSM (Ağır Yük)****Product Nr. 1038 Motor-Driven Die Arm Console Set - Model RSM (Heavy Duty)**

- Sipariş verirken yukarıdaki bilgileri bildirmeniz gerekmektedir.
- Please clearly indicate the above information while ordering.

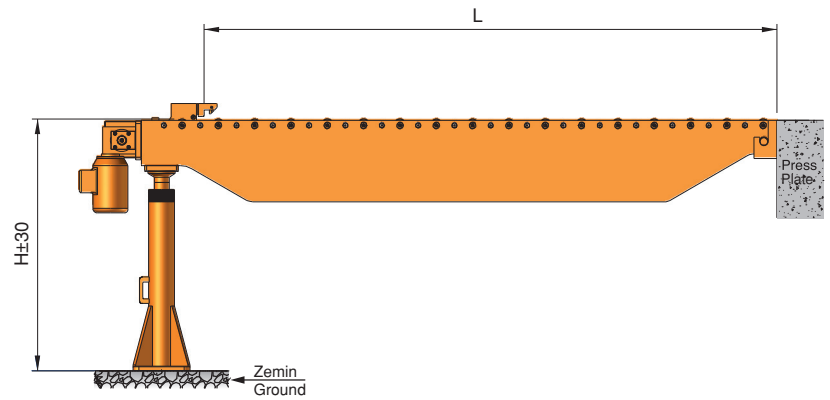

Referans Nr.	L1	L2	H	 (kg)
1040-PB0801P1V	250	225	367	15.55
1040-PB0801P2V	310	285	367	18.55
1040-PB0801P3V	428	403	367	21.50
1040-PB0801P4V	487	462	367	24.70
1040-PC1202P2V	-	397	367	-
1040-PJ1202P4V	660	-	500	-



### Ürün Nr. 1040 Hava Tahrikli Hidrolik Pompa Ünitesi

- Hidrolik Pompa hava tahriklidir. Hidrolik basınç ayarlanan seviyeye geldiğinde pompalamayı tasarruf etmek için keser. Diğer taraftan, çalışma basıncı azalır, pompa devamlılığı sağlamak için otomatik olarak basınç verir.
- Devre kontrol sistemi olası kaçakları denetleme ve engelleme fonksiyonuyla tasarlanmıştır. Pnömatik basınç devre dışı kalsa bile hidrolik basınç kalır.
- Basınç denetleme ve makinelere bağlanma özelliği vardır.
- CA ve CB-16 veya 25 bağlama pabuçlarıyla uygulama yapıldığında, PC12 model pompa kullanılması önerilir.
- Kapasite 350 max. Bar
- Basınç kontrol valfli

### Product Nr. 1040 Air Driven Hydraulic Pump Unit

- The hydraulic pump is driven by air. Once the hydraulic pressure reaches the pressure setting, it stops pumping which is energy saving. Meanwhile, if the working pressure reduces, the pump would supply pressure automatically to keep working pressure continuously.
- The circuit control system is designed with the function of checking and avoiding oil leakage. If pneumatic pressure out, the hydraulic pressure still maintains.
- It is capable of pressure inspection and connecting to machines.
- It is suggested to adopt pump model PC12 when used with clamp model CA&CB-16 or 25.
- Capacity 350 max. bar
- Pressure control valve

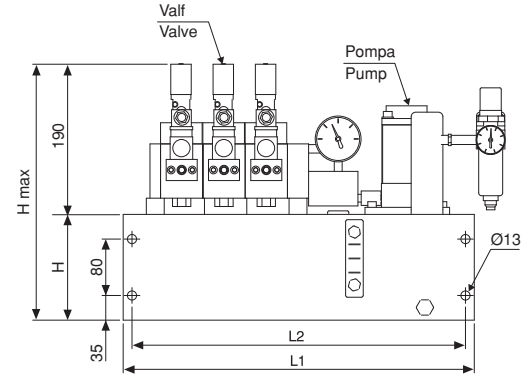
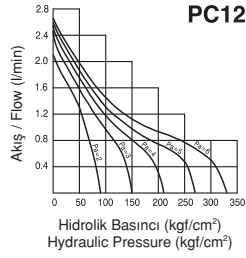
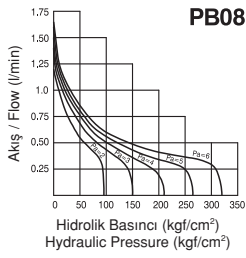

## Kontrol Ünitesi

### Control Unit

Referans Nr.	Devreli Circuits
1041-QDC01	1
1041-QDC02	2
1041-QDC03	3
1041-QDC04	4
1041-QMC04	4

### Ürün Nr. 1041 Kontrol Ünitesi

- QDC Pres kontrol ünitesi
- QMC Enjeksiyon kontrol ünitesi

### Product Nr. 1041 Control Unit

- QDC Press control unit
- QMC Injection control unit



Referans Nr.
1041-PLCSMS
1041-PLCGMT

#### Ürün Nr. 1041 PLC Kontrol Ünitesi

- PLC Kontrol Ünitesi Katagori 4
- PLC Kontrol Ünitesi

#### Product Nr. 1041 PLC Control Unit

- PLC Control Unit Category 4
- PLC Control Unit

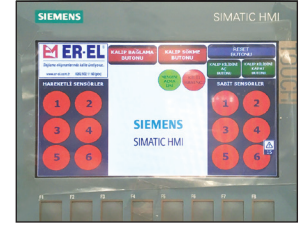
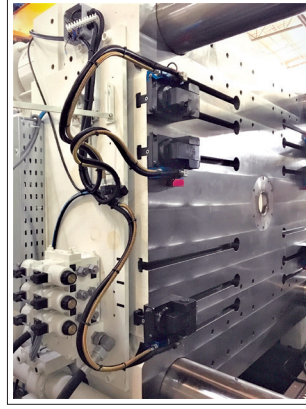

## Hidrolik El Pompası

### Hydraulic Hand Pump

Referans Nr.
1040-PB0101

#### Ürün Nr. 1040 Hidrolik El Pompası

- Sadece kalıp kaldırma kullanıldığında alternatif olarak hidrolik el pompası kullanılabilir.
- 250 Bar

#### Product Nr. 1040 Hydraulic Hand Pump

- If only the die lifter is used, the usage of a manual hydraulic pump can alternatively be used.
- 250 Bar

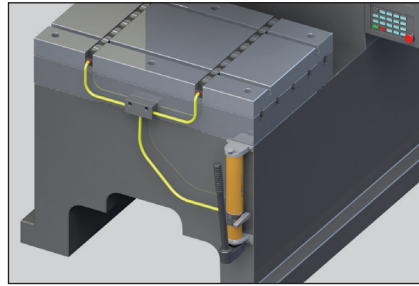

Alternatif Sistem  
Alternative Systems



## Ayak Pedallı Hidro-Pnömatik Pompa

### Foot Pedal Hydropneumatic Pump

Referans Nr.	Tank Yağ Kapasitesi Working Pressure	Aktif Yağ Miktarı Reservoir Capacity	Pompa Tipi Usable Oil	litre/dk. 50/700 bar lt./min. 50/700 bar	Hava Barı Air requirement min-max	Hava Tüketimi Air Consumption	Basınç Barı Pressure Rating	Yağ Çıkış Bağlantısı Connection Thread	Yağ Dolu Ağırlık Weight incl. Oil	Ölçüler Sizes mm
1040-PA0202	1500 cm <sup>3</sup>	1000 cm <sup>3</sup>	Tek Etkili Single Stage	600/110 cm <sup>3</sup>	5-7	250 l/d	50-700	3/8 NPT	12 kg	262x190x186

#### Ürün Nr. 1040 Ayak Pedallı Hidro-Pnömatik Pompa





- Ayak pedallı kullanımda hidro-pnömatik bir sistem ile daha kolay-rijit kullanımı olur.
- Ayak pedalı tek hareketle 5-6 bar ile çalışan sistem devreye girer ve insan kuvveti yerine kaldırıcılara yağı iletme-boşaltma görevini yapar sadece.
- Minimum 5 bar hava ile 700 bar hidrolik yağ basınç üreten hidropnömatik ayak pompaları çok farklı alanlarda kullanılabilir; hidrolik silindirler, kalıp kaldırıcılar, preslerin çalışma alanlarında.

#### Product Nr. 1040 Foot Pedal Hydro-Pneumatic Pump

- With foot pedal operation, hydro-pneumatic system makes it easier to use rigid.
- The foot pedal is operated with 5-6 bar in one movement and the system is activated and instead of manpower, it only serves to transfer oil to lifters.
- Hydropneumatic foot pumps producing 700 bar hydraulic oil pressure with minimum 5 bar air can be used in many different fields ; operating hydraulic cylinders, pullers, mold lifters and presses.

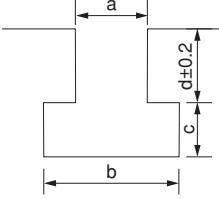

Tarih / Date:...../...../.....

Firma İsmi : Company Name :			
İletişim Tel & Adres : Contact Tel & Address :			
Yetkili Kişi : Authorized Person :			
Pres Tonajı / Press tonnage :			
Marka/Model/Tipi : Marke/Modell/Type:		Kalıp Referans No: Mold Reference No:	
Pres Pleyt Ölçüleri : Press Plate Measurements :	Üst Top	Alt Bottom	
	X:.....	Y:.....	X:..... Y:.....
Pres Tork Mesafesi : Press Torque Distance:			
Preste "U" Kanal Var mı? Is there U channel in Press?	Evet..... Yes .....	Hayır..... No .....	Ölçüsü..... its measure .....
Presin "T" Kanalı Şekli T-channel shape of Press	Alt Bottom	Üst Top	
			
Pres "T" Kanal Ölçüsü: T-channel measure of Press :			
ÜST TABLA: Top Table:	A:.....	B:.....	C:..... D:.....
ALT TABLA: Bottom Table:	A:.....	B:.....	C:..... D:.....
Kanal Merkez Aralığı: Channel Center Distance :			
Kalıp Çalışma Isısı / Mold Working Heat :			
Kalıp taşıma Şekli / Mold Transportation Shape :			
Hidrolik Pabuç Bilgileri / Hydraulic Clamp Information			
Pabuç Seçimi : Selection of clamp :	Plaka Kalınlığı Plate Thickness	Alt Bottom H:.....	Üst Top H:.....
Hidrolik Kalıp Kaldırma Bilgileri Die Lifter Hydraulic Information			
Kalıp Ağırlığı : Mold Weight	Kalıp Ölçüleri: Mold Size:	X:.....	Y:..... Z:.....
Kalıp Kaydırma Kolu Bilgileri Die Arm Informations:			
Taşıyacağı Yük : Load Capacity :	Ağır Model Heavy Model		Hafif Model Light Model
			
Destekli mi? Supported?	Evet..... Yes .....	Hayır..... No .....	
Model RS : Modell RS :	L= Kalıp uzunluğu Mold Length	H= Zemin yüksekliği Ground Height	W= Kalıp Ağırlığı Mold Weight
Komple kurulum sistem istiyor: Company wants whole system setup?	Evet..... Yes .....	Hayır..... No .....	
Bu Kısım ER-EL tarafından doldurulacaktır This part will be filled in by ER-EL			
Sistemde Kullanılacak Ekipmanları Model / Kod Bilgileri : Model / code information of the equipment to be used in the system:			





# HIZLI KALIP DEĞİŞTİRME SİSTEMİ (PRES)

QUICK MOLD CHANGE SYSTEM (PRESS)

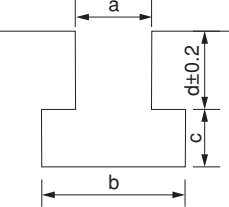

Tarih / Date:...../...../.....

Firma İsmi : Company Name :			
İletişim Tel & Adres : Contact Tel & Address :			
Yetkili Kişi : Authorized Person :			
Enjeksiyon Tonajı / Injection tonnage :			
Marka/Model/Tipi : Marke/Modell/Type :		Kalıp Referans No: Mold Reference No:	
Enjeksiyon çalışma Bilgileri Injection working information:			
Enjeksiyon Pleyt Ölçüleri Injection Plate Measurements		Sol Left X:..... Y:.....	Sağ Right X:..... Y:.....
Enjeksiyon Tork Mesafesi : Injection Torque Distance:			
Tezgahta *DIŞ* *THREAD* in Machine		Evet Yes .....	Hayır No .....
Tezgahta *DIŞ* var ise merkez aralığı : If there is thread in the machine, center interval :			
Enjeksiyon "T" Kanalı Şekli T-channel shape of Injection		Sol Left	Sağ Right
			
Enjeksiyon T-Kanal Ölçüsü: T-channel measure of Injection:			
Sol Tabla Left Table:		A:..... B:..... C:..... D:.....	
Sağ Tabla Right Table:		A:..... B:..... C:..... D:.....	
Kanal Merkez Aralığı : Center interval of channel :			
Çalışma Isısı : Working Heat :			
Hidrolik Pabuç Bilgileri Hydraulic Clamp Informations:			
Kalıp Ağırlığı : Weight of Mold :	Kalıp Plaka Kalınlığı: Mold Plate Thickness:	Sol Left H:....	Sağ Right H:.....
Komple kurulum sistem istiyor: Company wants whole system setup?		Evet Yes .....	Hayır No .....
BU KISIM ER-EL tarafından doldurulacaktır This part will be filled in by ER-EL			
Sistemde Kullanılacak Ekipmanları Model / Kod Bilgileri : Model / code information of the equipment to be used in the system:			



# HIZLI KALIP DEĞİŞTİRME SİSTEMİ (ENJEKSİYON)

QUICK MOLD CHANGE SYSTEM (INJECTION)

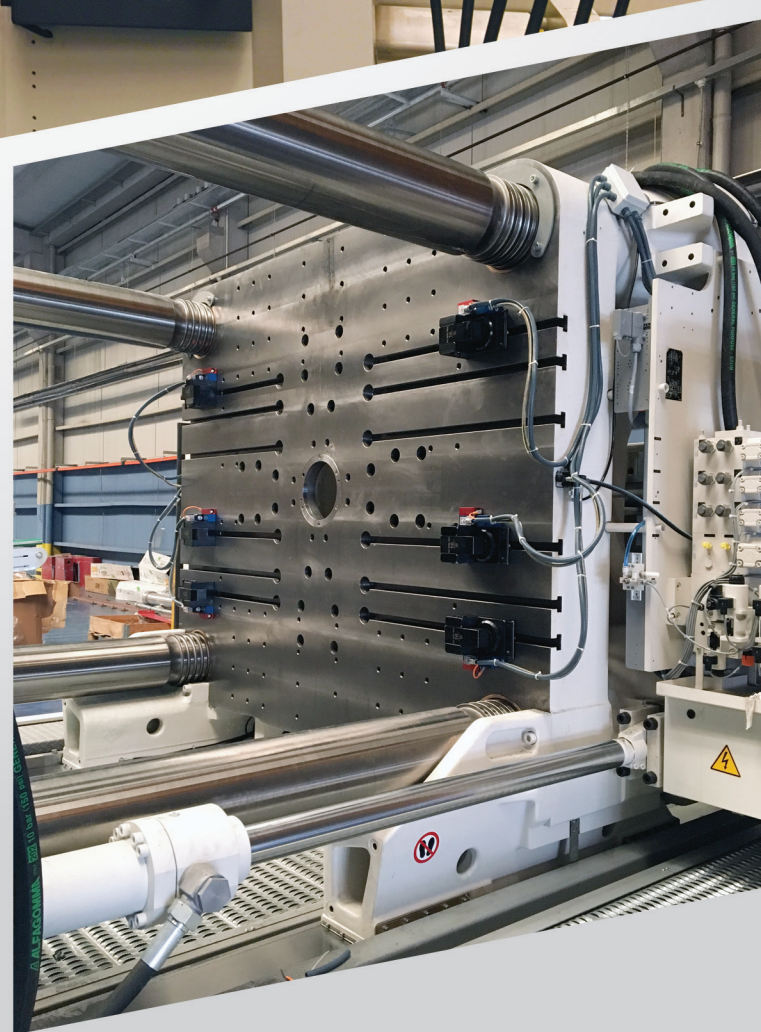





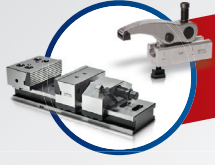

**Standart Ürünler**  
Standard Products



**Tek Dokunuş Bağlamalar**  
Single Touch Clamps



**5-Eksen Blok Bağlama Sistemi**  
5-Axis Clamping Block System



**Hidrolik Komponentler**  
Hydraulic Components



**Hızlı Kalıp Değişirme Sistemi**  
Quick Mold Change System



**Proje Bazlı Fikstür Uygulamaları**  
Project Based Fixture Applications



**ER-EL Zero Sistem**  
ER-EL Zero Point Clamping System



**MİKSAN**  
Standard Products

**Bağlama ekipmanlarında  
kalite üretiyoruz..**

*"We produce quality in clamping equipment"*

45'i aşkın ülkeye ihracat yapıyoruz...  
We export to more than 45 countries

**ER-EL®**

ER-EL MAKİNA YEDEK PARÇA İML. SAN. VE TİC. LTD. ŞTİ.

Çerkeşli OSB Mah. İMES 3 Blv. No: 14 Dilovası - Kocaeli

Tel: +90 262 502 11 60 Pbx Fax: +90 262 502 11 59

info@er-el.com.tr [www.er-el.com.tr](http://www.er-el.com.tr)



erelkalip  
miksanc.clamp



ERELkalip  
ClampMiksanc



erelkalip  
miksanc\_clamp



erelkalip



er-el-kalip

