

CNC YATAY İŞLEME KULELERİ

CNC HORIZONTAL CLAMPING CUBE

Nr.2670 Dikdörtgen kuleye
Nr.2310 çift açılır mengenerle
iş parçası bağlama şekli.

Nr.2670 clamping cube
with Nr.2310 vice applications

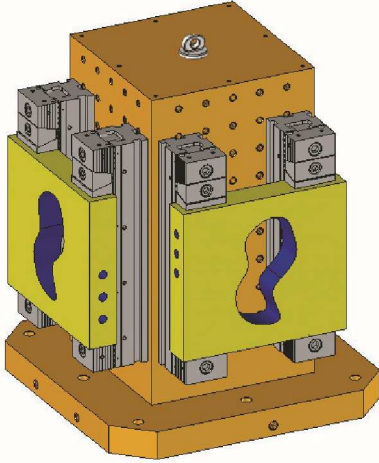
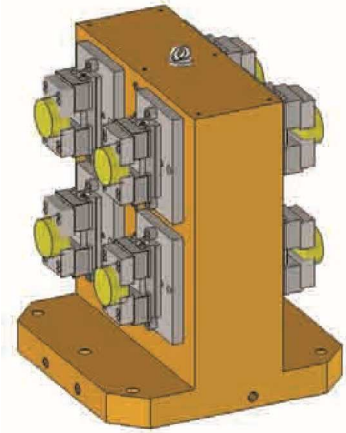

Nr.2650 kare kuleye
Nr.2430 mengenerle
iş parçası bağlama şekli

Nr.2650 clamping cube
with Nr.2430 vice applications

Nr.2650 kare kulenin
CNC yatay işleme tezgah
pleytine montaj şekli.

Nr.2650 clamping cube
CNC Horizontal machines
applications

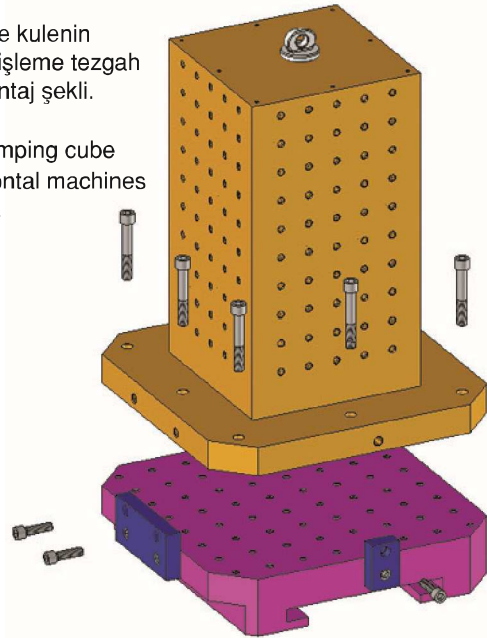
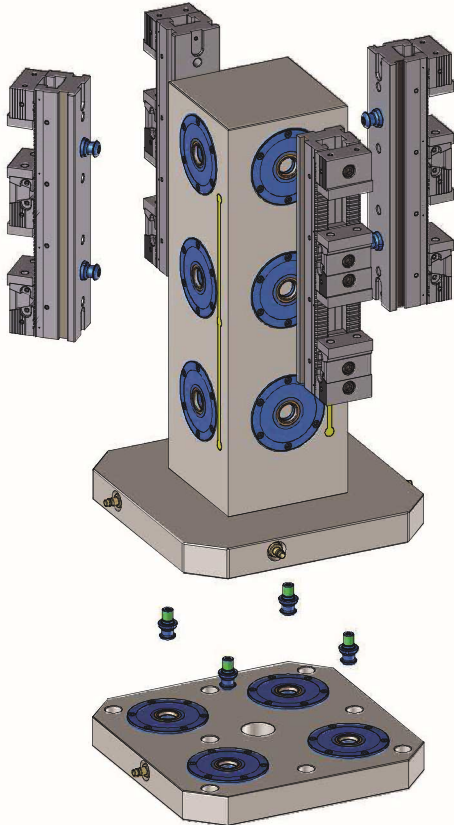

Referans Nr.	a	b	c	d	e	f	g	h	Ø1	j	k	s	s1	(kg)
2570-30012	300	300	220	100	250	90	40	30	18	M12	75	25	170	50
2570-40012	400	400	280	160	320	90	40	30	18	M12	75	30	240	88
2570-50012	500	500	345	200	400	90	50	35	18	M12	75	35	300	175
2570-63012	630	630	435	250	500	100	50	40	18	M12	105	40	360	298
2570-30016	300	300	220	100	250	90	40	30	18	M16	75	25	170	45
2570-40016	400	400	280	160	320	90	40	30	18	M16	75	30	240	84
2570-50016	500	500	345	200	400	90	50	35	18	M16	75	35	300	170
2570-63016	630	630	435	250	500	100	50	40	18	M16	105	40	360	293

Ürün Nr. 2570 L Gönye Delikli

- Malzeme : Döküm
- CNC yatay ve dik işleme tezgahlarında kullanılır.
- Standart bağlama ekipmanlarına uyumludur.
- Yüzeyinde M12 - M16 diş merkez aralığı 50 ± 0.02
- Çelik burçlu dişleri sertleştirilmiştir.

Product Nr. 2570 L Setsquare with Hole

- Material : Casting
- It is used in CNC Horizontal end Vertical processing benches.
- It is in compliance with Standard Coupling Equipment.
- M12 - M16 thread gap on it's surface is 50 ± 0.02 .
- It's steel bush threads are hardened.

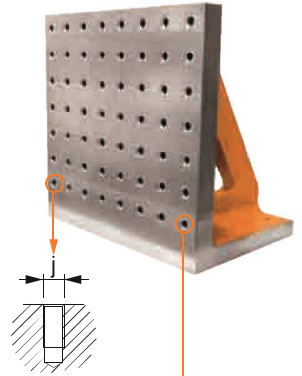

Gövdeye dişli
Referans Nr. 2570
Threaded body
Reference No. 2570

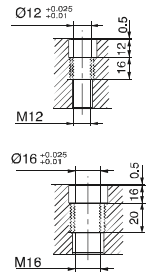
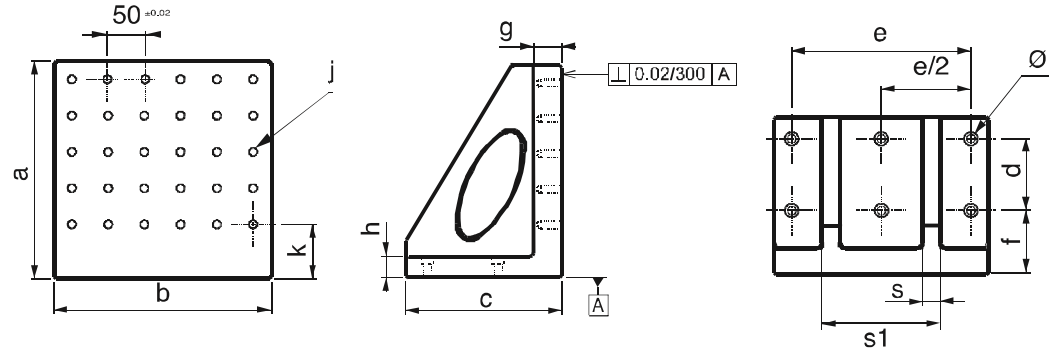

Çelik burçlu
Referans Nr. 2575
Steel bush
Reference No. 2575

Referans Nr.	a	b	c	d	e	f	g	h	Ø1	j	k	L	s	s1	(kg)
2590-30014	300	300	220	100	250	90	60	30	18	14	100	50	25	170	50
2590-40014	400	400	300	160	320	90	60	30	18	14	100	50	30	240	100
2590-50014	500	500	350	200	400	90	60	35	18	14	100	50	35	300	185
2590-63014	630	630	450	250	500	100	65	40	18	14	125	65	40	360	315
2590-30018	300	300	220	100	250	90	60	30	18	18	100	50	25	170	50
2590-40018	400	400	300	160	320	90	60	30	18	18	100	50	30	240	98
2590-50018	500	500	350	200	400	90	60	35	18	18	100	50	35	300	174
2590-63018	630	630	450	250	500	100	65	40	18	18	125	65	40	360	286

Ürün Nr. 2590 L Gönye T-Kanallı

- Malzeme : Döküm
- CNC yatay ve dik işleme tezgahlarında kullanılır.
- Standart bağlama ekipmanlarına uyumludur.
- T-Kanal ölçüleri 14mm - 18mm DIN 650 standartındadır.

Product Nr. 2590 L Setsquare T-Slot

- Material : Casting
- It is used in CNC Horizontal end Vertical processing benches.
- It is in compliance with Standard Coupling Equipment.
- T-Slot is in the standard of 14mm - 18mm DIN 650.

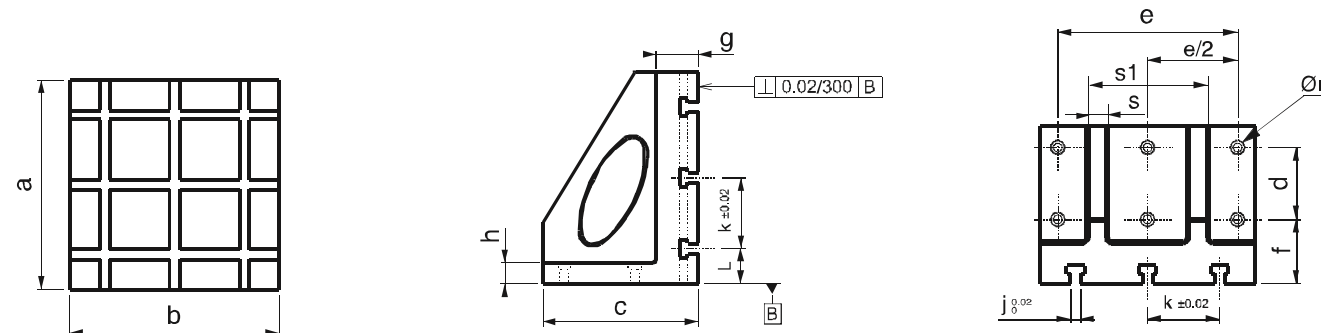

Referans Nr.	b	d	c	c1	A min.	A max.	Sıkma kuvveti Clamping force kgf
2600-400400	400	160	320	-	-	-	4000
2600-500500	500	200	400	-	-	-	4000
2600-630630	630	250	500	-	-	-	4000

Ürün Nr. 2600 Çatal Kule

- Kullanım alanı: CNC yatay işleme, Borvekt tezgahlarında silindirik parçaların iki yüzeyinde işleme kolaylığı sağlar.
- Hareketli yüzeylerin tamamı hassas taşlanmış ve sertleştirilmiştir.

Product Nr. 2600 Fork Tower

- Application area: Provides better operation on both sides of cylindric workpieces on cnc horizontal machines and bohrwerks.
- Entire moving surface is sensitively grinded and hardened.

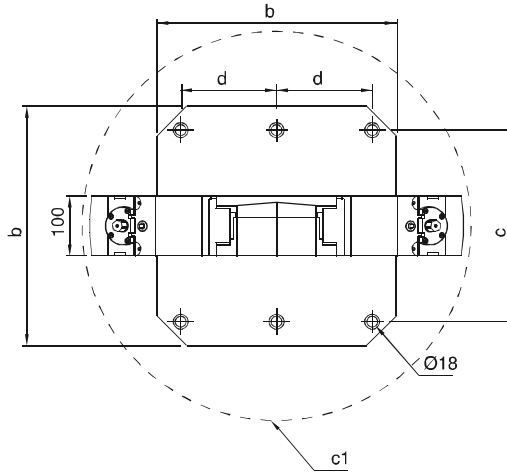
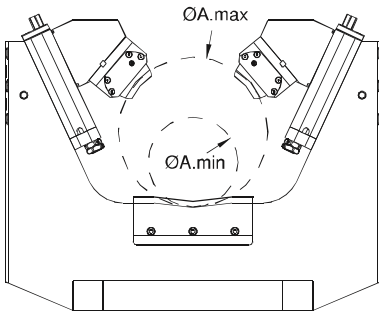

Oynar Başlı Çene
Head Moving Jaw

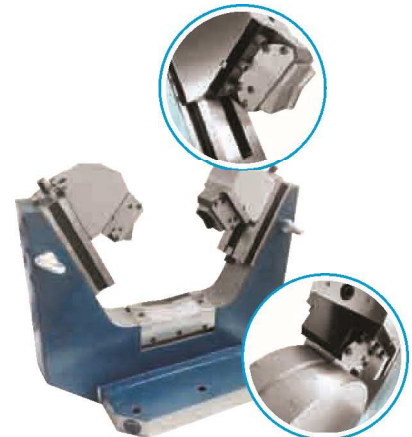
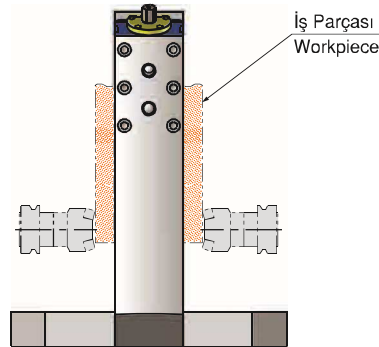
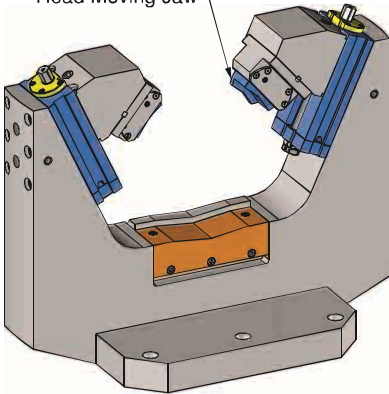

Referans Nr.	a	b	c	d	e	f	g	(kg)
2610-400250	500	400	250	320	200	55	50	180
2610-500300	600	500	300	400	250	75	50	240
2610-630350	700	630	350	500	315	100	50	390

Ürün Nr. 2610 Yatay İşleme Kulesi (Kare)

- İsteğe göre uygulama yapılabilmesi için yüzeyler deliksizdir.
- Malzeme : Döküm

Product Nr. 2610 Horizontal Processing Cube (Square)

- Application on the surface according to desired way.
- Material : Casting

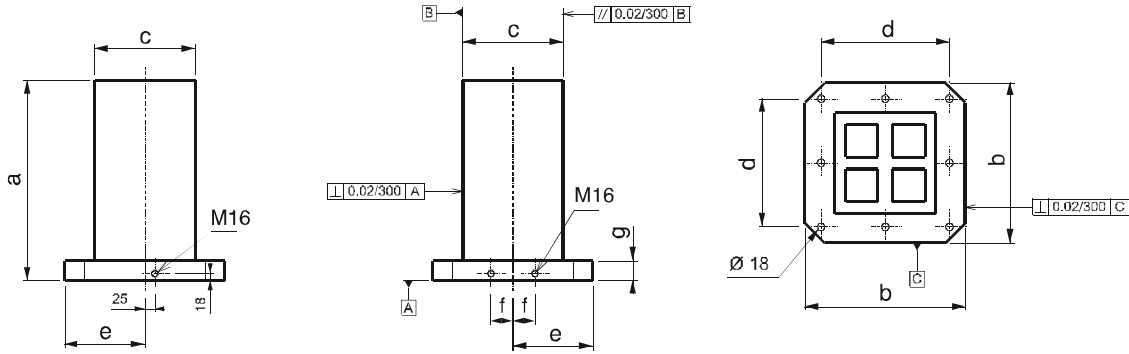

Referans Nr.	a	b	c	d	e	f	g	i	k	J ($\frac{0,02}{0,02}$)	(kg)
2630-40025014	500	400	250	320	200	55	50	150	100	14	165
2630-50030014	600	500	300	400	250	75	50	150	100	14	227
2630-63035014	700	630	350	500	315	100	50	150	125	14	375
2630-40025018	500	400	250	320	200	55	50	150	100	18	155
2630-50030018	600	500	300	400	250	75	50	150	100	18	223
2630-63035018	700	630	350	500	315	100	50	150	125	18	370

Ürün Nr. 2630 Yatay İşleme Kulesi (Kare) T-Kanallı

- Dört yüzeyine iş parçası bağlanabilir.
- Standart bağlama ekipmanlarına uyumludur.
- T-Kanal ölçüsü 14mm - 18mm DIN 650 standartındadır.
- Malzeme : Döküm

Product Nr. 2630 Horizontal Processing Cube (Square) with T-Slot

- Workpiece can be applied on four faces.
- It is in compliance with Standard Coupling Equipment.
- T-Slot is in the standard of 14mm - 18mm DIN 650.
- Material : Casting

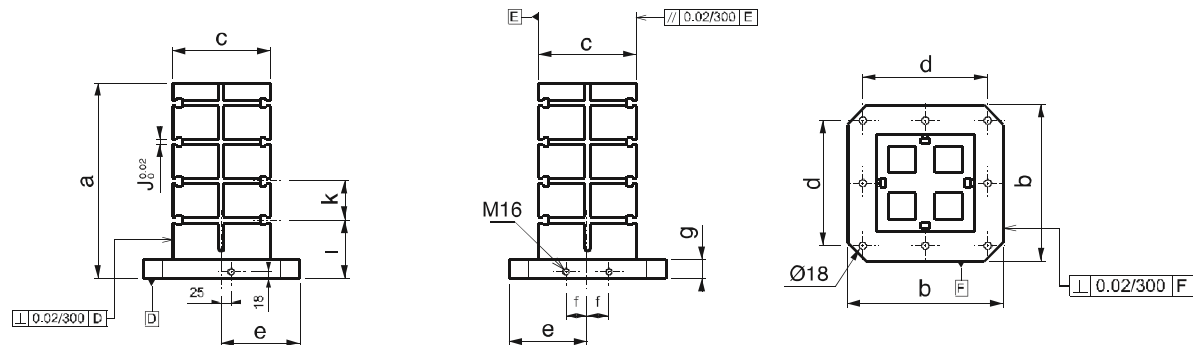

Referans Nr.	a	b	c	d	e	f	g	t	(kg)
2650-40025012	500	400	250	320	200	55	50	M12	170
2650-50030012	600	500	300	400	250	75	50	M12	230
2650-63035012	700	630	350	500	315	100	50	M12	380
2650-40025016	500	400	250	320	200	55	50	M16	168
2650-50030016	600	500	300	400	250	75	50	M16	228
2650-63035016	700	630	350	500	315	100	50	M16	376



Ürün Nr. 2650 Yatay İşleme Kulesi (Kare) Delikli

- Malzeme : Döküm
- Dört yüzeyine iş parçası bağlanabilir.
- Standart bağlama ekipmanlarına uyumludur.
- Her yüzeye M12 - M16 diş merkez aralığı 50mm \pm 0.02

Product Nr. 2650 Horizontal Processing Cube (Square) with Hole

- Material : Casting
- Workpiece can be applied on four faces.
- It is in compliance with Standard Coupling Equipment.
- M12 - M16 thread gap on it's surface is 50 ± 0.02 .

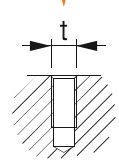
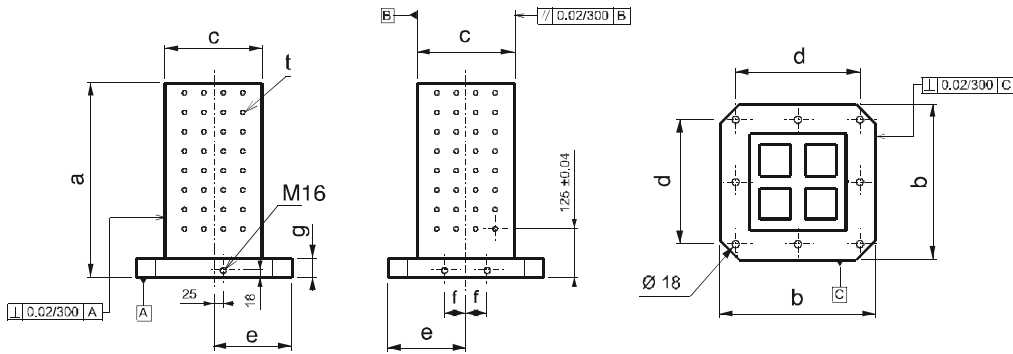

CNC Yatay İşleme Kulesi

CNC Horizontal Processing Cube

Referans Nr.	a	b	c	d	e	f	g	t	(kg)
2660-40025012	500	400	250	320	200	55	50	M12	170
2660-50030012	600	500	300	400	250	75	50	M12	230
2660-63035012	700	630	350	500	315	100	50	M12	380
2660-40025016	500	400	250	320	200	55	50	M16	168
2660-50030016	600	500	300	400	250	75	50	M16	228
2660-63035016	700	630	350	500	315	100	50	M16	376



Ürün Nr. 2660 Yatay İşleme Kulesi (Kare) Delikli

- Malzeme : Döküm
- Dört yüzeyine iş parçası bağlanabilir.
- Standart bağlama ekipmanlarına uyumludur.
- Her yüzeye M12 - M16 diş merkez aralığı 50mm \pm 0.02
- Çelik burçlu dişler sertleştirilmiştir.

Product Nr. 2660 Horizontal Processing Cube (Square) with Hole

- Material : Casting
- Workpiece can be applied on four faces.
- It is in compliance with Standard Coupling Equipment.
- M12 - M16 thread gap on it's surface is 50 ± 0.02 .
- It's steel bush threads are hardened.

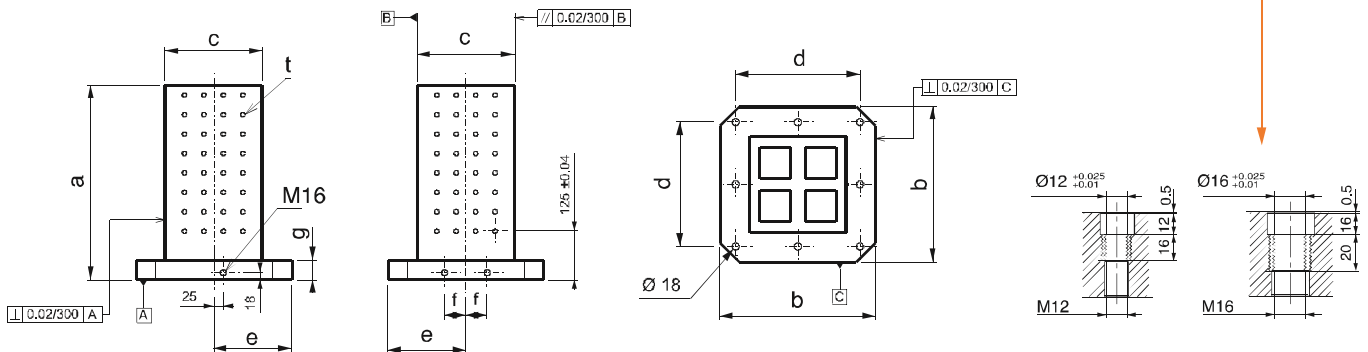

Referans Nr.	a	b	c	d	e	f	g	(kg)
2670-400150	500	400	150	320	200	55	50	175
2670-500200	600	500	200	400	250	75	50	265
2670-630250	700	630	250	500	315	100	50	484

Ürün Nr. 2670 Yatay İşleme Kulesi (Dikdörtgen)

- İsteğe göre uygulama yapılabilmesi için yüzeyler deliksizdir.
- Malzeme : Döküm

Product Nr. 2670 Horizontal Processing Cube (Rectangular)

- Application on the surface according to desired way.
- Material : Casting

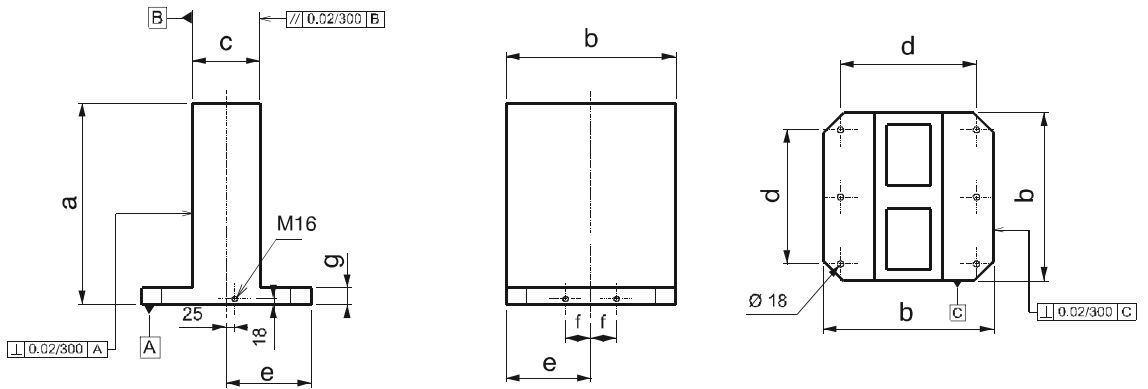

Referans Nr.	a	b	c	d	e	f	g	i	k (±0.02)	J ($\frac{0}{0.02}$)	(kg)
2690-40015014	500	400	150	320	200	55	50	150	100	14	165
2690-50020014	600	500	200	400	250	75	50	150	100	14	240
2690-63025014	700	630	250	500	315	100	50	150	125	14	455
2690-40015018	500	400	150	320	200	55	50	150	100	18	152
2690-50020018	600	500	200	400	250	75	50	150	100	18	238
2690-63025018	700	630	250	500	315	100	50	150	125	18	450

Ürün Nr. 2690 Yatay İşleme Kulesi (Dikdörtgen) T-Kanlı

- İki yüzüne iş parçası bağlanabilir.
- Standart bağlama ekipmanlarına uyumludur.
- T-Kanal ölçüsü 14mm - 18mm DIN 650 standartındadır.
- Malzeme : Döküm

Product Nr. 2690 Horizontal Processing Cube (Rectangular) with T-Slot

- Workpiece can be applied on four faces.
- It is in compliance with Standard Coupling Equipment.
- T-Slot is in the standard of 14mm - 18mm DIN 650.
- Material : Casting

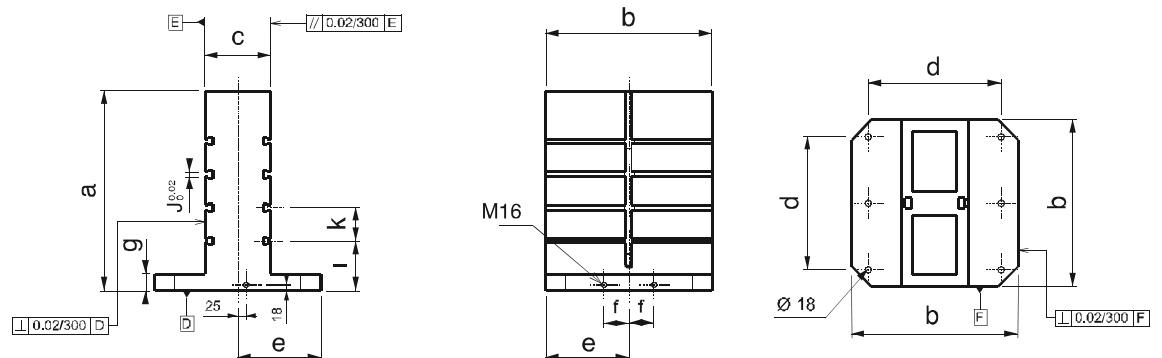

Referans Nr.	a	b	c	d	e	f	g	t	(kg)
2710-40015012	500	400	150	320	200	55	50	M12	170
2710-50020012	600	500	200	400	250	75	50	M12	250
2710-63025012	700	630	250	500	315	100	50	M12	475
2710-40015016	500	400	150	320	200	55	50	M16	164
2710-50020016	600	500	200	400	250	75	50	M16	248
2710-63025016	700	630	250	500	315	100	50	M16	470

Ürün Nr. 2710 Yatay İşleme Kulesi Dikdörtgen (Delikli)

- Malzeme : Döküm
- İki yüzeyine iş parçası bağlanabilir.
- Standart bağlama ekipmanlarına uyumludur.
- İki yüzeye M12 - M16 diş merkez aralığı 50mm ±0.02

Product Nr. 2710 Horizontal Processing Cube Rectangular (with Hole)

- Material : Casting
- Workpiece can be applied on two faces.
- It is in compliance with Standard Coupling Equipment.
- M12 - M16 thread gap on it's surface is 50 ± 0.02.

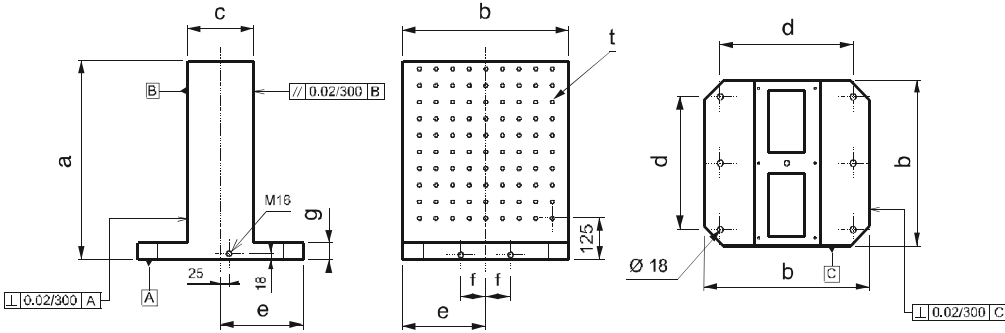

CNC Yatay İşleme Kulesi

CNC Horizontal Processing Cube

Referans Nr.	a	b	c	d	e	f	g	t	(kg)
2720-40015012	500	400	150	320	200	55	50	M12	170
2720-50020012	600	500	200	400	250	75	50	M12	250
2720-63025012	700	630	250	500	315	100	50	M12	475
2720-40015016	500	400	150	320	200	55	50	M16	164
2720-50020016	600	500	200	400	250	75	50	M16	248
2720-63025016	700	630	250	500	315	100	50	M16	470

Ürün Nr. 2720 Yatay İşleme Kulesi Dikdörtgen (Delikli)

- Malzeme : Döküm
- İki yüzeyine iş parçası bağlanabilir.
- Standart bağlama ekipmanlarına uyumludur.
- İki yüzeye M12 - M16 diş merkez aralığı 50mm ±0.02
- Çelik burçlu dişler sertleştirilmiştir.

Product Nr. 2720 Horizontal Processing Cube Rectangular (with Hole)

- Material : Casting
- Workpiece can be applied on two faces.
- It is in compliance with Standard Coupling Equipment.
- M12 - M16 thread gap on it's surface is 50 ± 0.02.
- It's steel bush threads are hardened.

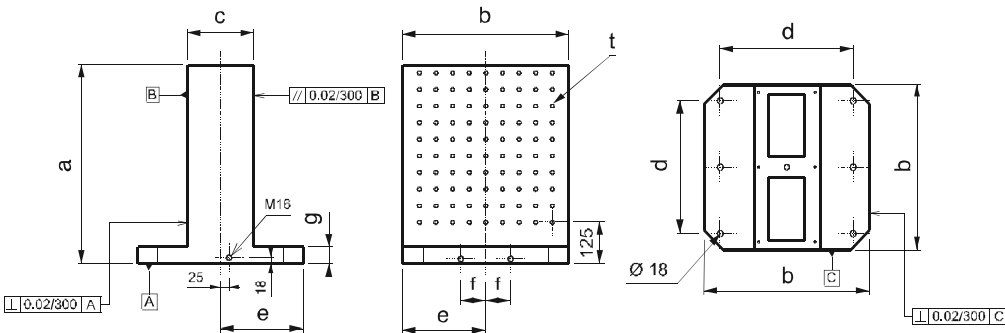

Referans Nr.	m	a	b	c	sw	e	g	h	Bir mapanın taşıma kuvveti Lifting Force of one Ringbolt Kgf	
2730-016	M16	39	85	35	30	30	45	10	660	370
2730-020	M20	39	85	35	30	30	45	10	1000	390





Ürün Nr. 2730 Kalıp Taşıma Mapası

- Bağlama ölçüsü M16 - M20
- Siyah Kaplama

Product Nr. 2730 Ringbolt for Mould Carrying

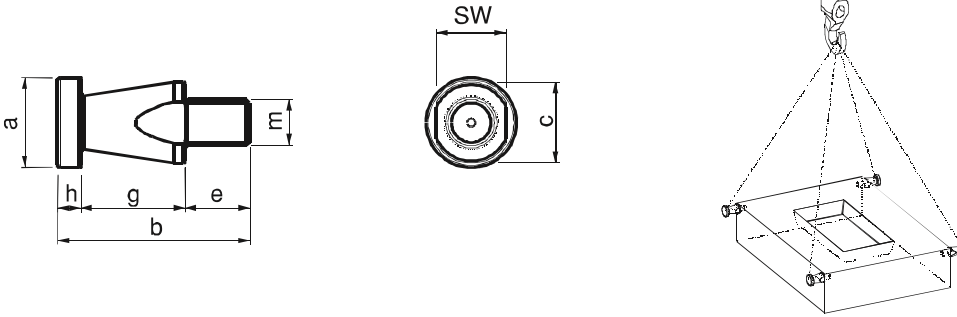
- Coupling Measurement: M16 - M20
- Black Coating



Referans Nr.	a	b	c	d	e	f	g	h	i	n	s	Bir mapanın taşıma kuvveti Lifting Force of one Ringbolt Kgf	
2750-044	44	108	32	27	15	22	23	11	37	11	22	400	525

Ürün Nr. 2750 Kalıp Taşıma Mapası

- Bağlama civata ölçüsü DIN 912 M10x35 inbus
- Siyah Kaplama

Product Nr. 2750 Ringbolt for Mould Carrying

- Coupling Bolt Measurement: DIN 912 M10x35 Inbus
- Black Coating

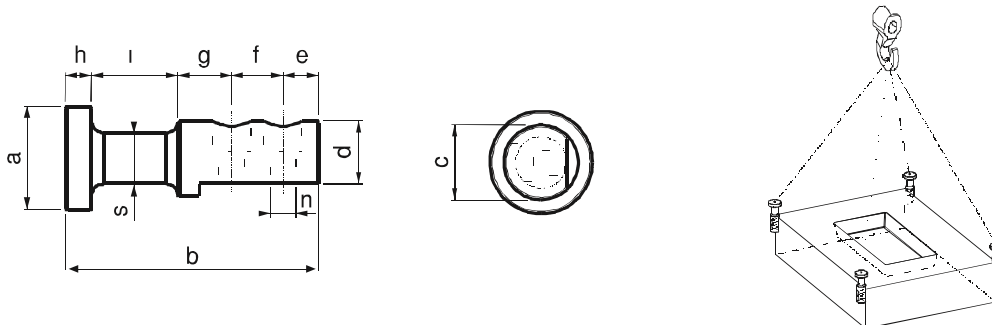

Referans Nr.	inch	hatve halve	L	b	h	n t7	c	k	j	e	m	s	Ø min	(g)
2770-0612	6" inch	1.5x60	72	32	32	12	5	15	20	11	22	10	6.5	1460
2770-0814	8" inch	1.5x60	98	37	37	14	5	24	25	13	22	14	8.5	2785
2770-1016	10" inch	1.5x60	110	42	42	16	5	30	30	13	29	14	10	4060
2770-1218	12" inch	1.5x60	130	50	52	18	5	39	30	15	32	17	12	6510
2770-1221	12" inch	1.5x60	130	50	52	21	5	39	30	17	32	19	12	6575
2775-0612	6" inch	1.5x60	72	28	37	12	5	15	20	11	17	10	6.5	1415
2775-0814	8" inch	1.5x60	95	35	67	14	5	24	25	13	19	14	8.5	4465
2775-1016	10" inch	1.5x60	110	38	77	16	5	30	30	13	19	14	10	6850
2775-1218	12" inch	1.5x60	130	48	77	18	5	39	30	15	23	17	12	10075
2775-1221	12" inch	1.5x60	130	48	77	21	5	39	30	17	23	19	12	9600



Ürün Nr. 2770 - 2775 CNC Torna Yumuşak Ayak

- 6" - 8" - 10" - 12" inch aynalar için

Product Nr. 2770 - 2775 CNC Lathe Chuck Soft Podous

- For chucks of 6" - 8" - 10" and 12"

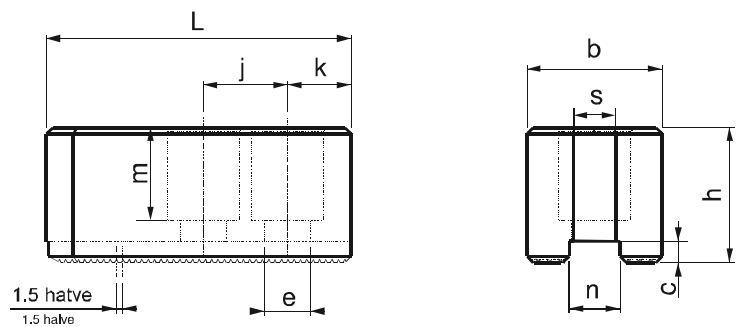

Yumuşak Ayak T-Pabucu

CNC Soft Podous T-Nut

Referans Nr.	inch	L	h	n T6	n1	h1	d	j	(g)
2790-0610	6" inch	38	18.5	12	18	7.5	M10	20	55
2790-0812	8" inch	45	21.5	14	21	8.5	M12	25	85
2790-1012	10" inch	52	21.5	16	22	8.5	M12	30	115
2790-1214	12" inch	55	33.5	18	26.5	13.5	M14	30	225
2790-1216	12" inch	55	27	21	29	13.5	M16	30	210



Ürün Nr. 2790 CNC Torna Yumuşak Ayak T-Pabucu

- 6" - 8" - 10" - 12" inch aynalar için
- Sertleştirilmiş
- Siyah Kaplama

Product Nr. 2790 CNC Lathe Chuck Soft Podous T-Nut

- For chucks of 6" - 8" - 10" and 12"
- Hardened
- Black Coating

