

Quick Die Change System

It's an era for making high frequency of die changing with multiple patterns and small quantity. In order to save die changing time and ensure operational safety, it is just in time to apply Quick Die Change System.

Application

- Press - hydraulic press - injection
- Different automatic machine clamp system

Die Lifter

Model: DL - DB - DLS - DBS

- Hydraulic type, spring type.
- Install in the T-slot or U-slot.



Electronic Control Operation Panel

- It is equipped with interlock control switch for connecting to the machine.
- It is designed with safety control device which prevents any operation error.



Die Arm

Model: RC - RD - RE/RF - RS

- Can pull out and push in the die from the plate easily.
- There are 4 different models of die arm.

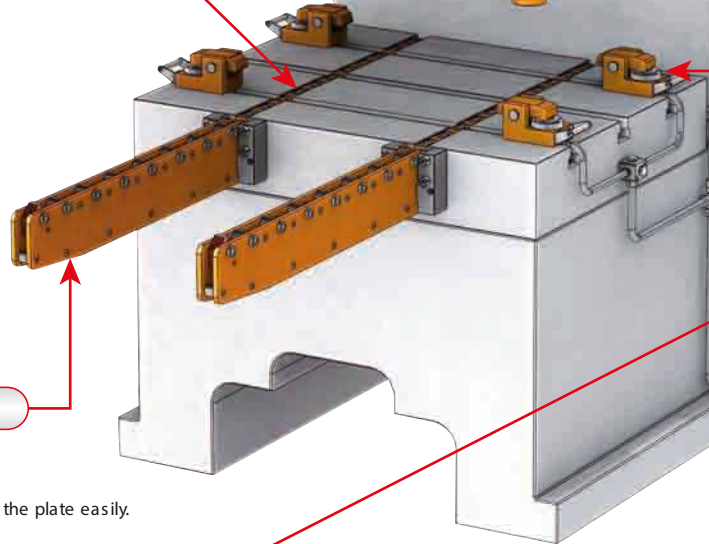

Die Clamp

Model: CA - CV - CB - CC

- Replacing the traditional method which uses screws to fix dies.
- Using T-Slots to lock or fix directly on the plate.

Air Driven Hydraulic Pump Unit

- Capable of pressure inspection and interlocking with machines.
- The movements between each devices will be pinned down mutually in order to ensure operational safety.

