

DLS

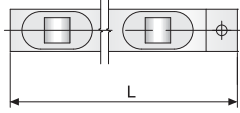

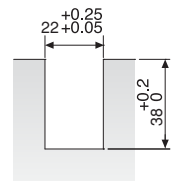
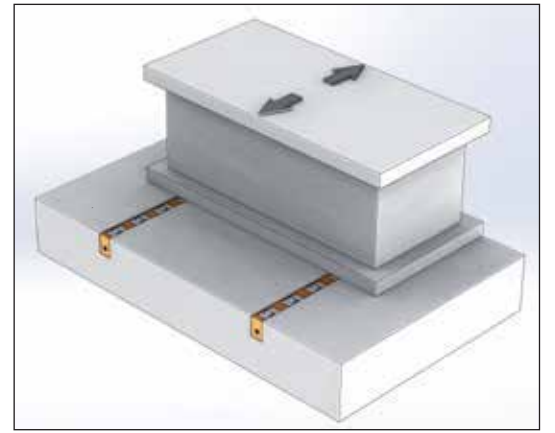

DBS

Dış Ölçüler Outline Dimensions	D□22 Serisi / Serial 
Pleyt için işlem ölçüsü (U-Kanal) Processing Size for Plate (U-slot)	



Model DLS Hareket Yönü
Model DLS Movement Direction

Referans Nr.	L	D□22					
		DLS22			DBS22		
		Rulo Roller (DLS)		Kapasite Capacity kg	Misket Ball (DBS)		Kapasite Capacity kg
1022-0200	200	3	3	240	5	5	200
1022-0300	300	5	5	400	7	7	280
1022-0400	400	6	6	480	10	10	400
1022-0500	500	8	8	640	12	12	480
1022-0600	600	9	9	720	15	15	600
1022-0700	700	11	11	880	17	17	680
1022-0800	800	12	12	960	20	20	800
1022-0900	900	14	14	1120	22	22	880
1022-1000	1000	15	15	1200	25	25	1000

Ürün Nr. 1022 Hidrolik Kalıp Kaldırma Model DLS-DBS

- Standart Sıcaklık : 60°
- Opsiyonel Sıcaklık : 160°

Product Nr. 1022 Die Lifter Hydraulic Model DLS-DBS

- Standard Temperature : 60°
- Optional Temperature : 160°

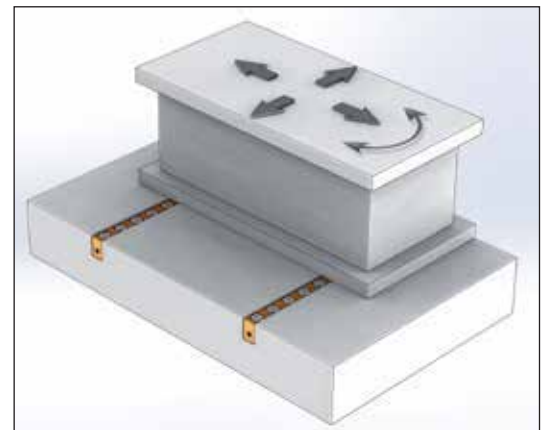

Model DBS Hareket Yönü
Model DBS Movement Direction