

Dış Ölçüler Outline Dimensions	D□50 Serisi / Serial DL50-2100'den önce	D□50 Serisi / Serial DL50-2100'den sonra
		
Pleyt için işlem ölçüsü (U-Kanal) Processing Size for Plate (U-slot)		

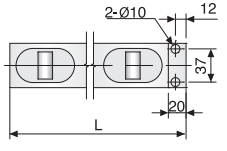

Model DL Hareket Yönü
Model DL Movement Direction

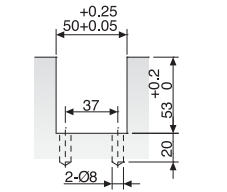
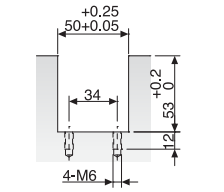
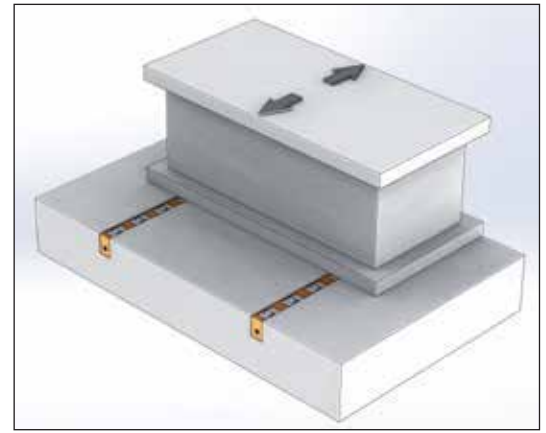
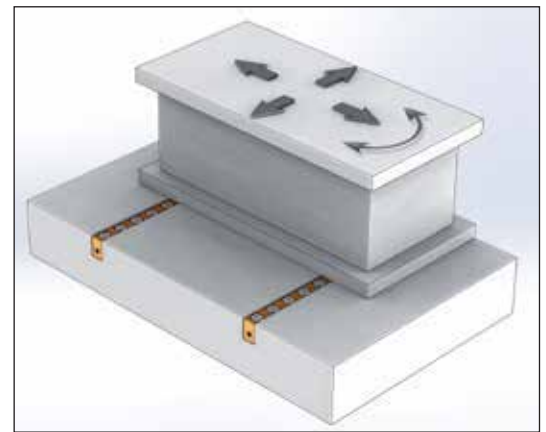

Model DB Hareket Yönü
Model DB Movement Direction

Referans Nr.	L	D□50				Hid. Silindir Hyd. cylinder	
		DL50		DB50		Piston	Kapasite Capacity kg
		Rulo Roller (DL)	Kapasite Capacity kg	Misket Ball (DB)	Kapasite Capacity kg		
1020-0200	200	2	1000	4	640	2	2200
1020-0300	300	3	1500	6	960		
1020-0400	400	4	2000	9	1440		
1020-0500	500	5	2500	11	1760	3	3300
1020-0600	600	6	3000	13	2080		
1020-0700	700	7	3300	16	2560		
1020-0800	800	8	3300	18	2880	4	4400
1020-0900	900	9	4400	20	3200		
1020-1000	1000	10	4400	23	3680		
1020-1100	1100	11	4400	25	4000	5	5500
1020-1200	1200	12	5500	27	4320		
1020-1300	1300	13	5500	29	4640		
1020-1400	1400	14	5500	31	4960	6	6600
1020-1500	1500	15	5500	33	5280		
1020-1600	1600	16	6500	35	5600		
1020-1700	1700	17	6500	38	6080	7	7700
1020-1800	1800	18	6500	40	6400		
1020-1900	1900	19	6500	42	6720		
1020-2000	2000	20	7700	44	7040	8	8800
1020-2100	2100	21	7700	46	7360		
1020-2200	2200	22	7700	48	7680		
1020-2300	2300	23	7700	50	7700	8	8800
1020-2400	2400	24	8800	52	8320		
1020-2500	2500	25	8800	54	8640		

Ürün Nr. 1020 Hidrolik Kalıp Kaldırma Model DL-DB

- Standart Sıcaklık : 60°
- Opsiyonel Sıcaklık : 160°

Product Nr. 1020 Die Lifter Hydraulic Model DL-DB

- Standard Temperature : 60°
- Optional Temperature : 160°