

DL

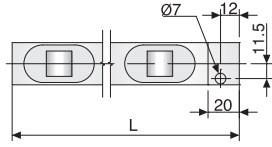

DB

| | |
|-------------------------------------------------------------------------------|------------------------------------------------------------------------------------|
| Dış Ölçüler Outline Dimensions | D□36 Serisi / Serial |
| |  |
| Pleyt için işlem ölçüsü (U-Kanal) Processing Size for Plate (U-slot) |  |

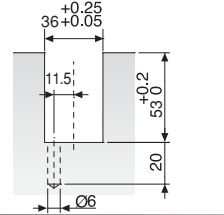
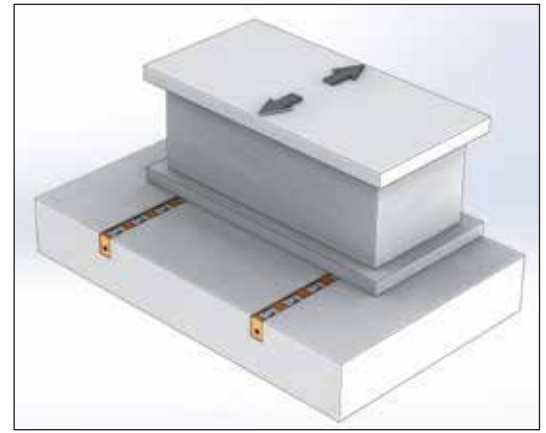

Model DL Hareket Yönü
Model DL Movement Direction

| Referans Nr. | L | D□36 | | | | Hid. Silindir Hyd. cylinder | |
|--------------|------|------------------|----------------------|------------------|----------------------|-----------------------------|----------------------|
| | | DL36 | | DB36 | | Piston | Kapasite Capacity kg |
| | | Rulo Roller (DL) | Kapasite Capacity kg | Misket Ball (DB) | Kapasite Capacity kg | | |
| 1020-0200 | 200 | 3 | 1050 | 5 | 600 | 2 | 1700 |
| 1020-0300 | 300 | 5 | 1750 | 7 | 840 | | |
| 1020-0400 | 400 | 6 | 1700 | 10 | 1200 | | |
| 1020-0500 | 500 | 8 | 2600 | 12 | 1440 | 3 | 2600 |
| 1020-0600 | 600 | 9 | 2600 | 15 | 1800 | | |
| 1020-0700 | 700 | 11 | 2600 | 17 | 2040 | | |
| 1020-0800 | 800 | 12 | 2600 | 20 | 2400 | | |
| 1020-0900 | 900 | 14 | 3500 | 22 | 2640 | 4 | 3500 |
| 1020-1000 | 1000 | 15 | 3500 | 25 | 3000 | | |
| 1020-1100 | 1100 | 16 | 3500 | 27 | 3240 | | |
| 1020-1200 | 1200 | 17 | 4400 | 30 | 3600 | | |
| 1020-1300 | 1300 | 18 | 4400 | 32 | 3840 | | |
| 1020-1400 | 1400 | 19 | 4400 | 35 | 4200 | 5 | 4400 |
| 1020-1500 | 1500 | 20 | 4400 | 37 | 4400 | | |
| 1020-1600 | 1600 | 22 | 5300 | 40 | 4800 | | |
| 1020-1700 | 1700 | 24 | 5300 | 42 | 5040 | | |
| 1020-1800 | 1800 | 25 | 5300 | 45 | 5300 | | |
| 1020-1900 | 1900 | 27 | 5300 | 47 | 5300 | | |

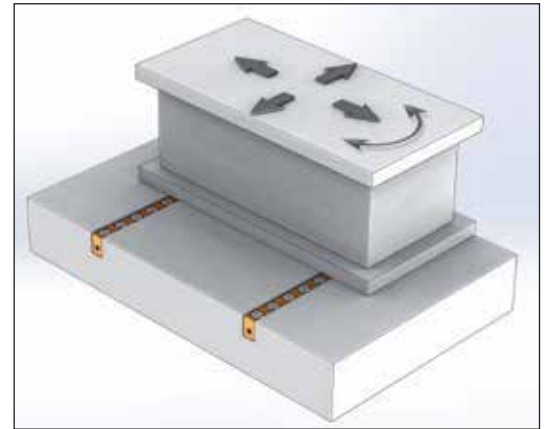

Model DB Hareket Yönü
Model DB Movement Direction

Ürün Nr. 1020 Hidrolik Kalıp Kaldırma Model DL-DB

- Standart Sıcaklık : 60°
- Opsiyonel Sıcaklık : 160°

Product Nr. 1020 Die Lifter Hydraulic Model DL-DB

- Standard Temperature : 60°
- Optional Temperature : 160°