

Dış Ölçüler Outline Dimensions	<p>□18 Serisi / Serial</p> 
Pleyt için işlem ölçüsü (U-Kanal) Processing Size for Plate (U-slot)	

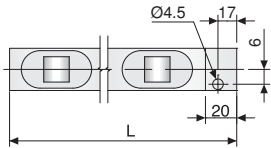
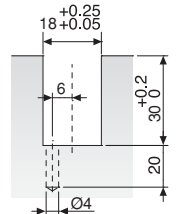
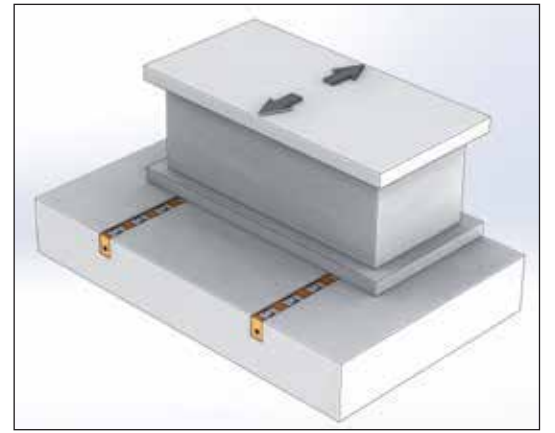

Model DL Hareket Yönü
Model DL Movement Direction

Referans Nr.	L	□18				Hid. Silindir Hyd. cylinder	Piston	Kapasite Capacity kg
		Rulo Roller (DL)	Kapasite Capacity kg	Misket Ball (DB)	Kapasite Capacity kg			
1020-0200	200	3	300	5	250	2	560	
1020-0300	300	5	500	7	350			
1020-0400	400	6	560	10	500			
1020-0500	500	8	800	12	600	3	840	
1020-0600	600	9	840	15	750			
1020-0700	700	11	840	17	840			
1020-0800	800	12	1120	20	1000	4	1120	
1020-0900	900	14	1120	22	1100			
1020-1000	1000	15	1250	25	1250	5	1400	

Ürün Nr. 1020 Hidrolik Kalıp Kaldırma Model DL-DB

- Standart Sıcaklık : 60°
- Opsiyonel Sıcaklık : 160°

Product Nr. 1020 Die Lifter Hydraulic Model DL-DB

- Standard Temperature : 60°
- Optional Temperature : 160°

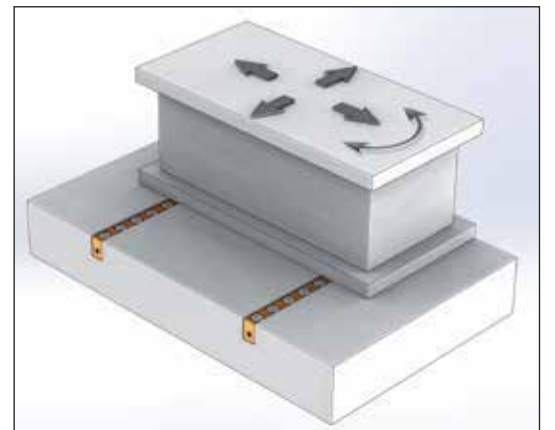

Model DB Hareket Yönü
Model DB Movement Direction