

Referenz-Nr. Order No.	d	d1	h	h1	L	 (kg)
2385-130	48	32	91	60	151	3.05

2385

- Präzision 0,01 Bearbeitung Durchmesser 9-130 mm und Tiefe 170 mm

2385

- It works with 0.01 sensitivity in diameter 9-130 mm and 145 mm depth. Because of replaceable function kater and cartouche it is perfect in using.

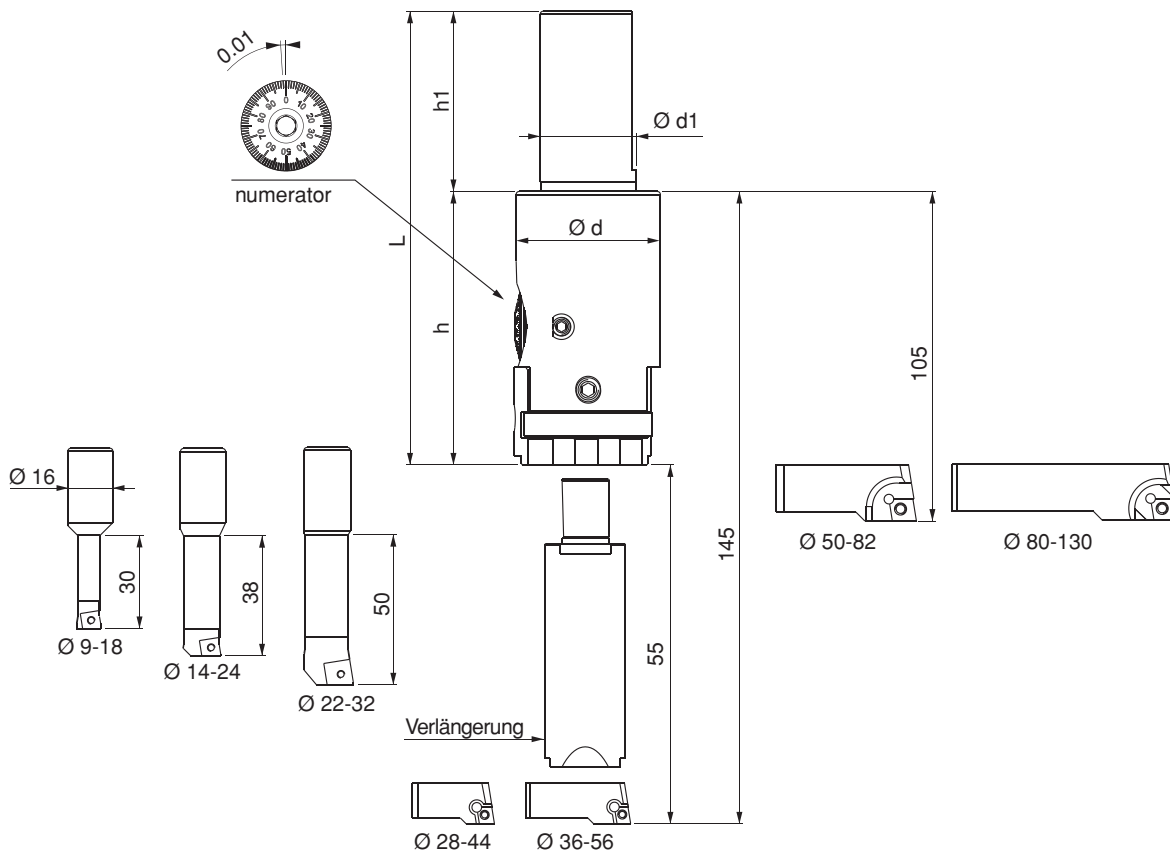

Hinweis :
ab 52 mm Durchmesser
kann mit dem
Grundkörper 105 mm
Tiefe und mit Verlängerung
eine Tiefe von 145 mm
erreicht werden

Note; from diameter 52: It reaches 105 mm depth with its slot and 145 mm depth with its extended kate

Referenz-Nr. Order No.	Type	Einsatz-Type Type of Inserts	Rotation	Progress	ap
2386-00918	09-18 Einsatz	CCMT 06	2700 d/dk.	F 75	0.1 - 0.5 mm
2386-01424	14-24 Einsatz	CCMT 06	2500 d/dk.	F 75	0.1 - 0.5 mm
2386-02232	22-32 Einsatz	CCMT 09	2000 d/dk.	F 50	0.1 - 1 mm
2386-02844	28-44 Kartusche	CCMT 06	1800 d/dk.	F 60	0.1 - 1 mm
2386-03656	36-56 Kartusche	CCMT 06	1500 d/dk.	F 65	0.1 - 1.5 mm
2386-05082	50-82 Kartusche	CCMT 09	1500 d/dk.	F 70	0.1 - 2 mm
2386-80130	80-130 Kartusche	CCMT 09	360 d/dk.	F 75	2 mm
2386-00055	Verlängerung	-	400 d/dk.	F 75	1.5 mm