

Referans Nr.	Clamping Stroke	W1	W2	H3	H4	L2	W	L	H2	d	P	H5	L1
2141-00010	1	38	8	6	3	15	45	33.5	10	5.2	36	5	30.5
2141-00015	2	60	12	9	5	22	70	50	15	8.2	55	7	46

Referans Nr.	H	D	H1	R	A	W3	M1	Allowable Screw Torque (N m)	Clamping Force Kgf	 (g)
2141-00010	30	13	20	63	12	6	M4x0.7	10	400	85
2141-00015	46	19	30	100	18	10	M5x0.8	27	600	290

Product Nr. 2141 Side Clamps
Body

- Black coating

Jaw

- Hardened
- Black coating

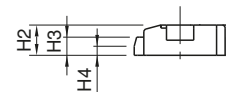
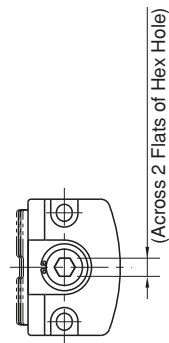
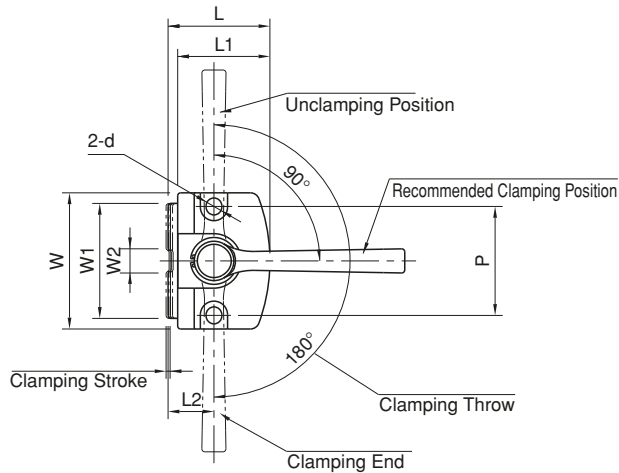
How To Use
