



Referenz-Nr. Order No.		m	h		s	s1	e1	d	sw 	L	e	b	c	Spannkraft Clamping Force Kgf	 (g)
			min	max											
1120-014 T	14	M12	0	50	12-66	25	100	M14	8	104	35.5	38	13	1600	1700
1120-016 T	16	M12	0	50	12-66	25	100	M14	8	104	35.5	38	13	1600	1700
1120-018 T	18	M12	0	50	12-66	25	100	M14	8	104	35.5	38	13	1600	1700
1130-014 T	14	M12	0	60	15-83	30	113	M18	10	130	39	48	17.5	2000	3040
1130-016 T	16	M12	0	60	15-83	30	113	M18	10	130	39	48	17.5	2000	3055
1130-018 T	18	M12	0	60	15-83	30	113	M18	10	130	39	48	17.5	2000	3085
1130-020 T	20	M12	0	60	15-83	30	113	M18	10	130	39	48	17.5	2000	3135
1130-022 T	22	M12	0	60	15-83	30	113	M18	10	130	39	48	17.5	2000	3150

**1120-1130**

• **1120** (a) 14-18 in T-Nut wird Inbusschraube M12 DIN 508 mit T-Nutmutter verwendet. Spannhöhe 0-50 mm, Spannweite 54 mm, Spannkraft 1600 kg.

• **1130** (a) 14-22 in T-Nut wird Inbusschraube M12 DIN 508 mit T-Nutmutter verwendet. Spannhöhe 0-60 mm, Spannweite 68 mm, Spannkraft 2000 kg.

**1120-1130**

• **1120** (a) 14-18 is used in T-Slot and M12 imbus bolt is used with DIN 508 T-Nut. Height clamping gap of the piece is 0-50mm, back-and-forth movement distance is 54mm. Clamping force is 1600 kgf.

• **1130** (a) 14-22 is used in T-Slot and M12 imbus bolt is used with DIN 508 T-Nut. Height clamping gap of the piece is 0-60mm, back-and-forth movement distance is 68mm. Clamping force is 2000 kgf.

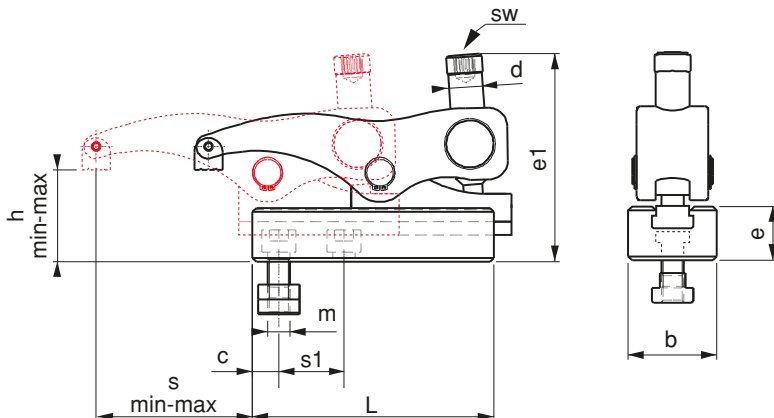
**ANWENDUNG;**

- 1- Zwischenelement an Werkstück befestigen
- 2- Grundkörper auf Zwischenelement verschieben
- 3- Werkstück mit Inbusschraube befestigen
- 4- Werkstück ist zum Bearbeiten bereit

**APPLICATION;**

- 1- Slide cradle is brought to suitable form with the work piece and then it is fixed
- 2- Upper body is driven to the slide and it is brought to desired position
- 3- Work piece is fixed with the imbus bolt of the clamp
- 4- Then the work piece becomes ready to be machined.

**Verwendung**

Injektionsmaschinen, Pressen, Fräsmaschinen, Bohrzentren, verschiedene Industriemaschinen

**Area of Use**

Injection Machines, Presses, Milling Machines, Drilling Machines and various Industrial Machines

