

DL

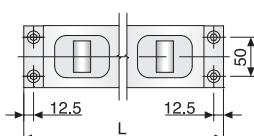

Dış Ölçüler Outline Dimensions	D□80 Serisi / Serial 
Pleyt için işlem ölçüsü (U-Kanal) Processing Size for Plate (U-slot)	

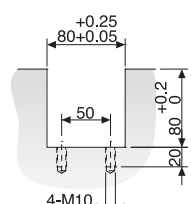
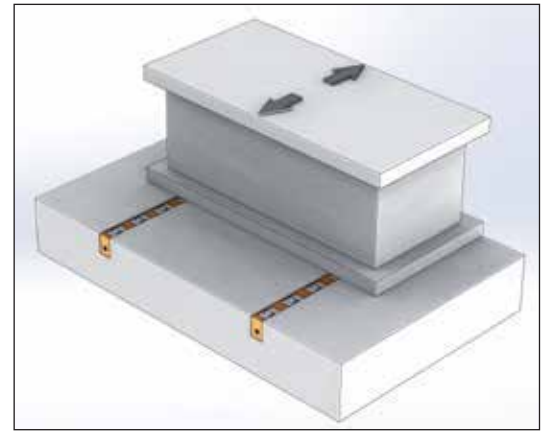

Model DL Hareket Yönü
Model DL Movement Direction

Referans Nr.	L	D□80			
		DL80		Hid. Silindir Hyd. cylinder	
		Rulo Roller (DL)	Kapasite Capacity kg	Piston	Kapasite Capacity kg
1020-0200	200	-	-	-	-
1020-0300	300	-	-	-	-
1020-0400	400	-	-	-	-
1020-0500	500	5	3250	2	5600
1020-0600	600	6	3900		
1020-0700	700	7	4550	3	8400
1020-0800	800	8	5200		
1020-0900	900	9	5850		
1020-1000	1000	10	6500	4	11200
1020-1100	1100	11	7150		
1020-1200	1200	12	7800		
1020-1300	1300	13	8450		
1020-1400	1400	14	9100	5	14000
1020-1500	1500	15	9750		
1020-1600	1600	16	10400	6	16800
1020-1700	1700	17	11050		
1020-1800	1800	18	11700		
1020-1900	1900	19	12350	7	19600
1020-2000	2000	20	13000		
1020-2100	2100	21	13650		
1020-2200	2200	22	14300		
1020-2300	2300	23	14950	8	22400
1020-2400	2400	24	15600		
1020-2500	2500	25	16250		

Ürün Nr. 1020 Hidrolik Kalıp Kaldırma Model DL-DB

Product Nr. 1020 Die Lifter Hydraulic Model DL-DB