

Dış Ölçüler Outline Dimensions	D□28 Serisi / Serial
	
Plejt için işlem ölçüsü (U-Kanal) Processing Size for Plate (U-slot)	

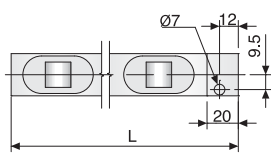

Model DL Hareket Yönü
Model DL Movement Direction

Referans Nr.	L	D□28				Hid. Silindir Hyd. cylinder	
		DL28		DB28		Piston	Kapasite Capacity kg
		Rulo Roller (DL)	Kapasite Capacity kg	Misket Ball (DB)	Kapasite Capacity kg		
1020-0200	200	3	750	5	475		
1020-0300	300	5	1250	7	665	2	1260
1020-0400	400	6	1260	10	950		
1020-0500	500	8	1890	12	1140		
1020-0600	600	9	1890	15	1425	3	1890
1020-0700	700	11	1890	17	1615		
1020-0800	800	12	2520	20	1900		
1020-0900	900	14	2520	22	2090	4	2520
1020-1000	1000	15	3150	25	2375		
1020-1100	1100	16	3150	27	2565	5	3150
1020-1200	1200	17	3150	30	2850		
1020-1300	1300	18	3780	32	3040		
1020-1400	1400	19	3780	35	3325	6	3780
1020-1500	1500	20	3780	37	3515		
1020-1600	1600	22	4410	40	3800		
1020-1700	1700	24	4410	42	3990	7	4410
1020-1800	1800	25	4410	45	4275		
1020-1900	1900	27	5040	47	4465	8	5040

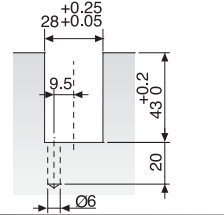
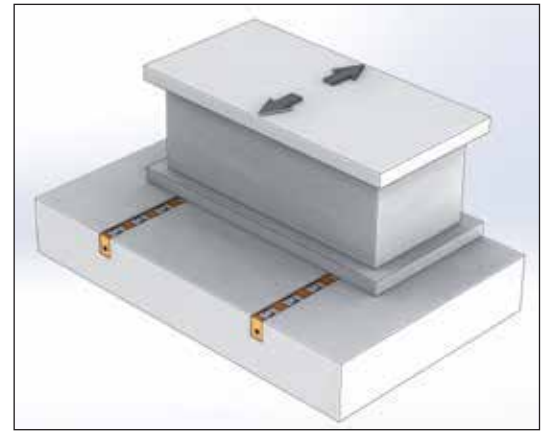
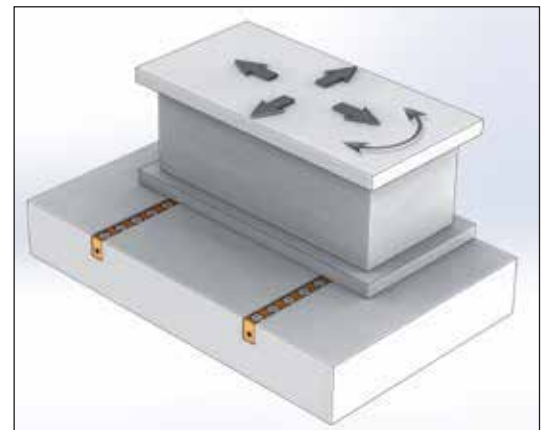

Model DB Hareket Yönü
Model DB Movement Direction

Ürün Nr. 1020 Hidrolik Kalıp Kaldırma Model DL-DB

Product Nr. 1020 Die Lifter Hydraulic Model DL-DB