

Outline Dimensions	<p>D□36 Serial</p>
Processing Size for Plate (U-slot)	

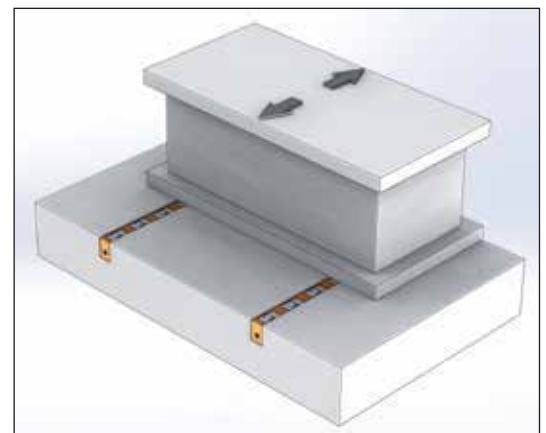

Model DL Movement Direction

Referans Nr.	L	D□36				Hyd. cylinder	
		DL36		DB36		Piston	Capacity kg
		Rulo Roller (DL)	Capacity kg	Ball (DB)	Capacity kg		
1020-0200	200	3	1050	5	600	2	1700
1020-0300	300	5	1750	7	840		
1020-0400	400	6	1700	10	1200		
1020-0500	500	8	2600	12	1440	3	2600
1020-0600	600	9	2600	15	1800		
1020-0700	700	11	2600	17	2040		
1020-0800	800	12	2600	20	2400		
1020-0900	900	14	3500	22	2640	4	3500
1020-1000	1000	15	3500	25	3000		
1020-1100	1100	16	3500	27	3240		
1020-1200	1200	17	4400	30	3600		
1020-1300	1300	18	4400	32	3840	5	4400
1020-1400	1400	19	4400	35	4200		
1020-1500	1500	20	4400	37	4400		
1020-1600	1600	22	5300	40	4800		
1020-1700	1700	24	5300	42	5040	6	5300
1020-1800	1800	25	5300	45	5300		
1020-1900	1900	27	5300	47	5300		

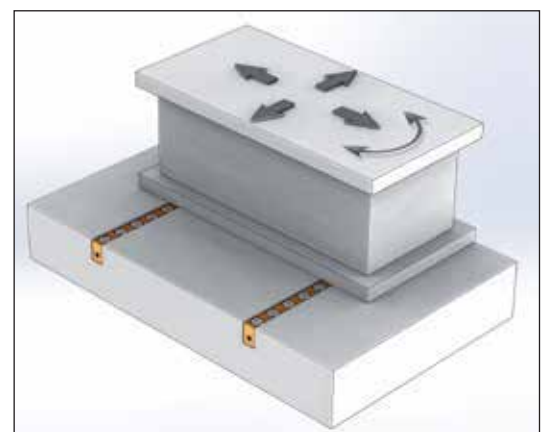

Model DB Movement Direction