

Referans Nr.	D	H (±0.01)	D1	L	H1	H2	H3	d (H7)	H4	M	W	Clamping Force Kgf	Allowable Screw Torque (N-m)	(g)
0950-08050	40	50	22	46	30	20	18	40	7.5	M8	4	800	8	500
0950-12080	60	80	32	69	50	30	25	60	10.5	M12	6	1500	22	1600

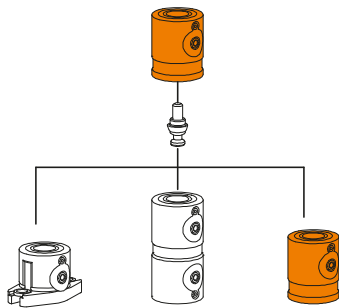

Product Nr. 0950 5-Axis Clamping Block Extension

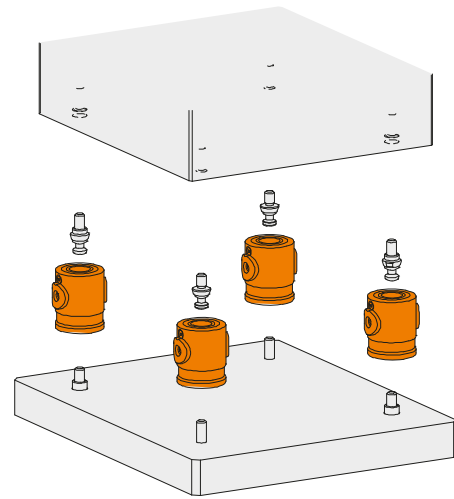
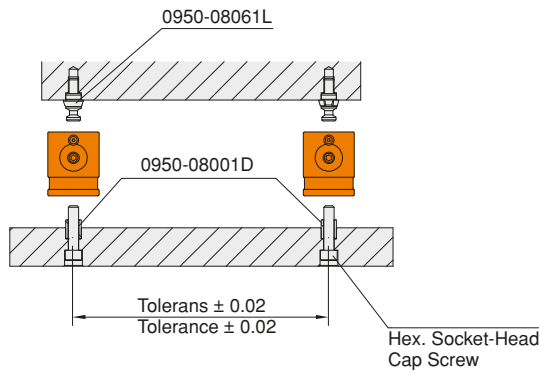
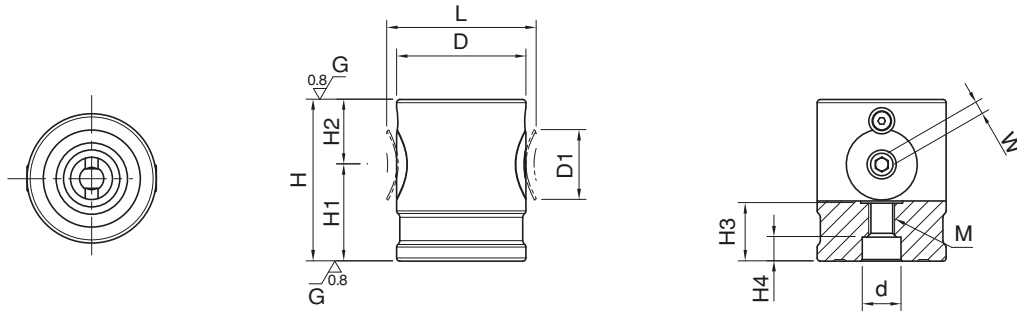

Application Example

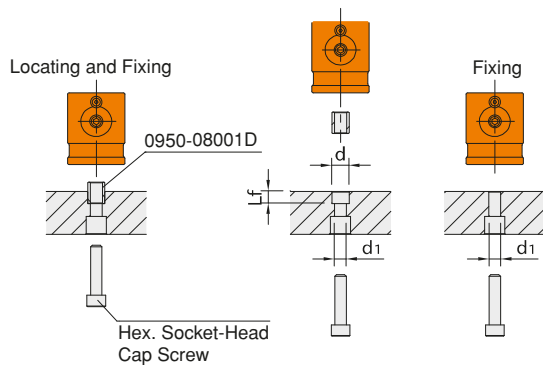

Referans Nr.	d (H7)	Lf	d1 (+0.2 0)
0950-08050	12	8.5	12
0950-12080	18	12.5	18