

Referenz-Nr. Order No.	D	H (±0.01)	D1	L	H1	W	Spannkraft Clamping Force Kgf	zulässiges Drehmoment Allowable Screw Torque (N-m)	 (g)
0950-08080	40	80	22	46	20	4	800	8	700
0950-12125	60	125	32	69	30	6	1500	22	2600

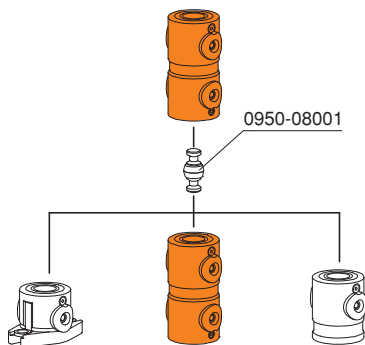

0950

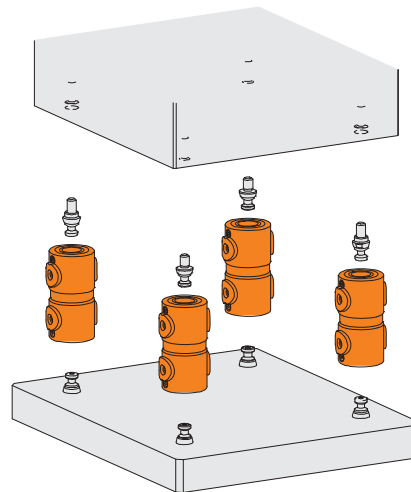
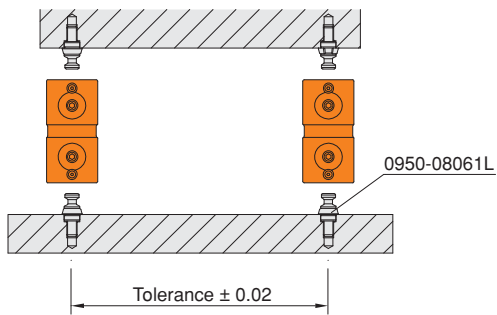
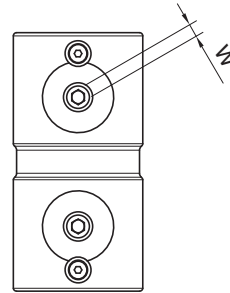
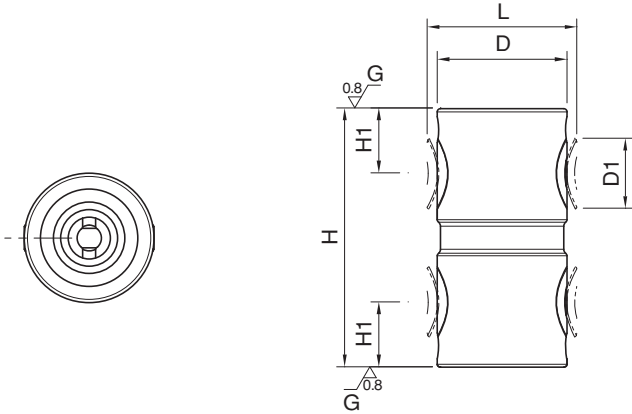

Anwendungsbeispiel / Application Examples

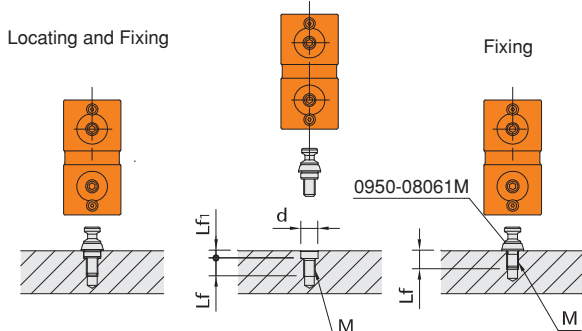

Referenz-Nr. Order No.	d (H7)	Lf	Lf1	M
0950-08080	12	13	5.5	8
0950-12125	18	19	6.5	12