

Referenz-Nr. Order No.	D	H (±0.01)	D1	L	H1	H2	W	H3	d	P	W1	Spannkraft Clamping Force Kgf	zulässiges Drehmoment Allowable Screw Torque (N-m)	⚖ (g)
0950-08040	40	40	22	46	20	20	65	10	9	50	4	800	8	300
0950-12063	60	63	32	69	33	30	95	15	13	75	6	1500	22	1400

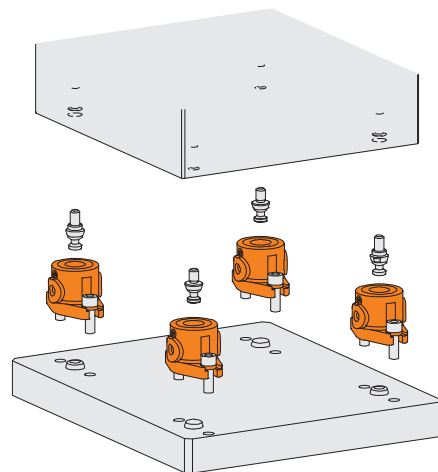

0950

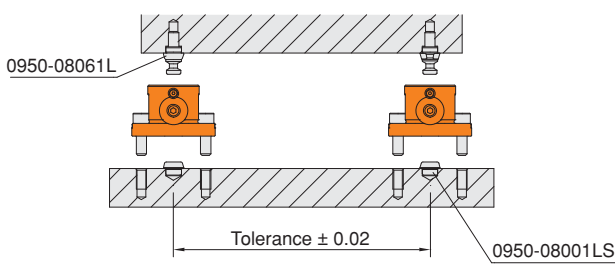
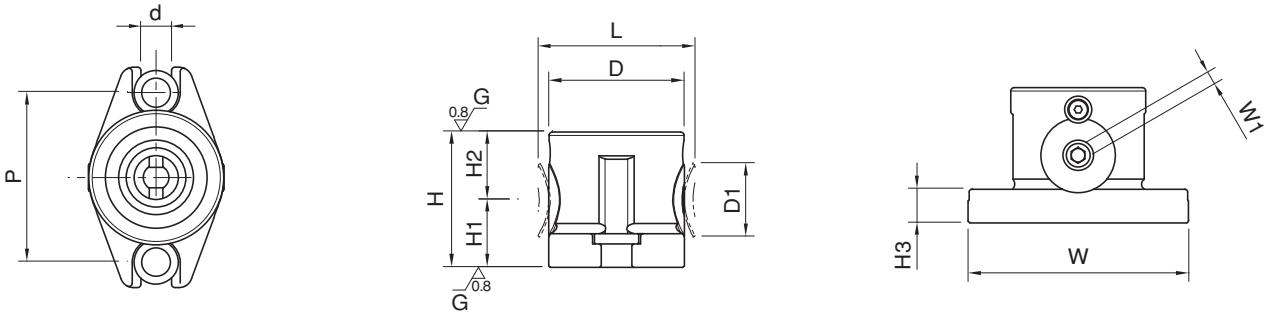

**Anwendungsbeispiel / Application Examples**

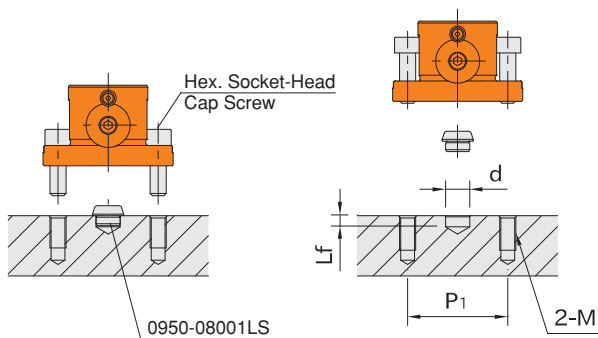

Referenz-Nr. Order No.	d (H7)	Lf	M	P1
0950-08040	40	40	M8	20
0950-12063	60	63	M12	30