

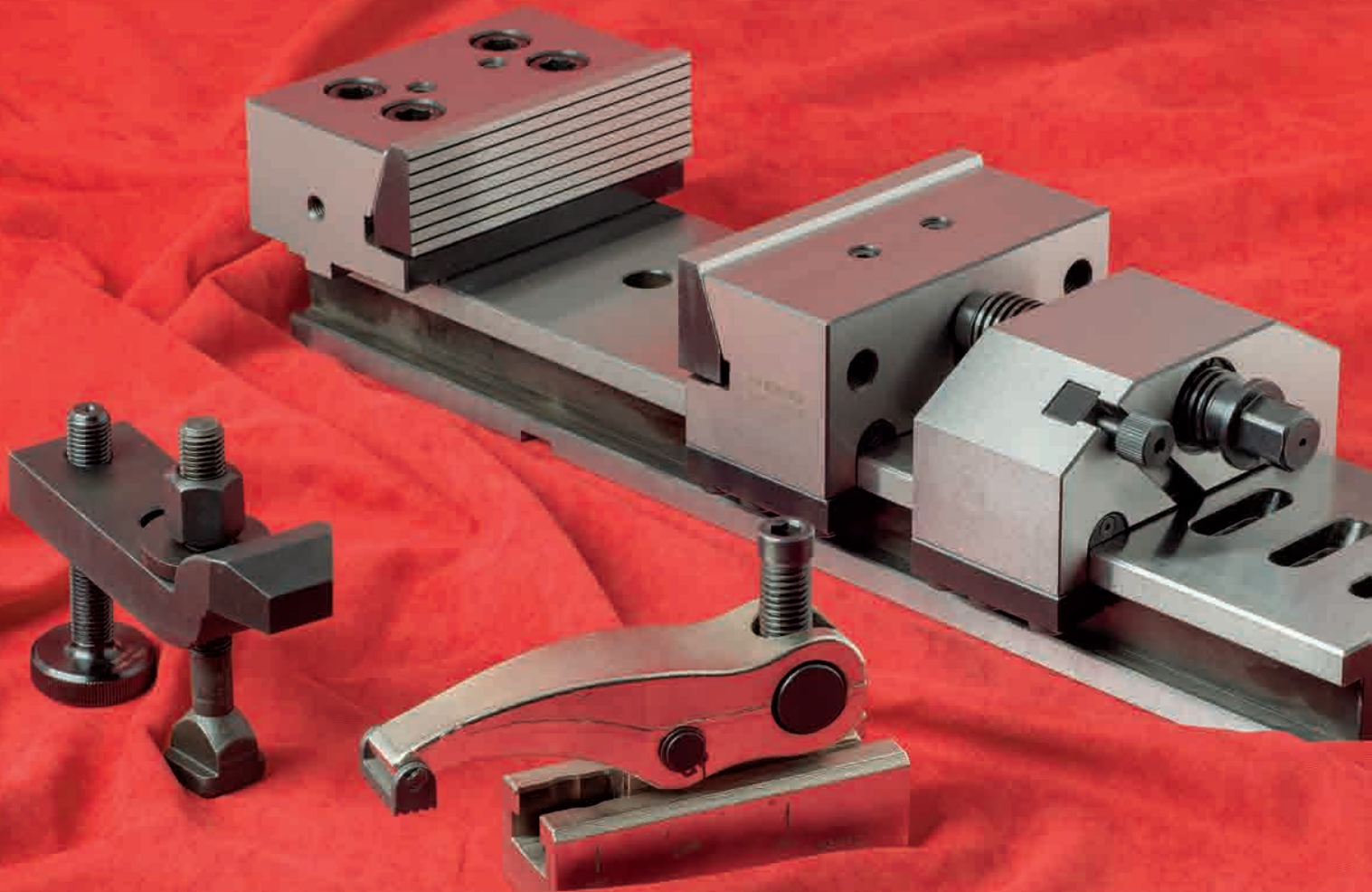

Spann-und Vorrichtungssysteme
Mold and Workpiece Clamping Systems



2019 Katalog
Catalogue



Alle Bilder, technische Zeichnungen und Texte in diesem Katalog sind rechtlich geschützt und können ohne Erlaubnis von ER-EL Makina weder kopiert noch angewendet werden.

"Entire rights of the pictures, technical drawings and explanations taking place in the catalogue belong to ER-EL MACHINE SPARE PARTS MANUFACTURING INDUSTRY AND TRADE LTD. CO. They can not be reproduced and used without permission"

ER-EL behält sich das Recht vor, Änderungen in den technischen Zeichnungen im Katalog machen und messen die Zeit, es für notwendig erachtet.

ER-EL, when it deems necessary in the catalog of technical drawings and measurements reserves the right to make changes.

Werte Kunden,

ER-EL MAKINA wurde in 1989 gegründet und ist im Bereich Spannelemente ein Symbol des Vertrauens und der Qualität. Jedes Jahr erhöhen wir unsere Kapazität und wachsen stetig. Seit 1998 haben wir unser Produktprogramm regelmäßig erweitert. Auf Produktentwicklung legen wir großen Wert. ER-EL stellt jedes Jahr immer wieder neue Produkte vor. Wir sind zertifiziert mit ISO 9001:2015, ISO14001:2015, OHSAS 18001:2007 und verfügen über CE-Zertifikat 21032019CE0075, 21032019CE0076.

Wir sind stolz, mit über 3.500 Produkten Marktführer zu sein. Die Produktvielfältigkeit ist nur ein Teil. Primär ist für uns das Vertrauen und die kontinuierliche Qualität wichtig.

Außer unseren Standard-Produkten, sind bei uns ebenfalls projektbasierte Fertigungen erhältlich. Unsere Spannsysteme sind vor allem in Unternehmen der Verteidigungsindustrie, Luft- und Raumfahrt-Industrien, Automobil- und Maschinen-Industrien zu sehen.

ER-EL beliefert weltweit mit Focus Europa über 24 Länder.

ER-EL mit dynamischer Belegschaft und Expertenteam bietet Ihnen sowohl Standardartikel als auch Produkte gemäß Kunden-Spezifikation an.

Für Ihr Vertrauen danken wir Ihnen und freuen uns auf eine langfristige Zusammenarbeit.

Mit freundlichen Grüßen
Geschäftsführung

OUR ESTEEMED CUSTOMER;

Our Company was established in 1989 and ever since the establishment, ER-EL name has become the symbol of confidence and quality in Mould Clamping and Processing Systems. Together with developing the existing capacity, company's total employment has shown an increasing value. The Company has increased its product variety in the area of Clamping Equipment. ER-EL gives great importance to Research And Development (R&D) activities and it increases product range in every year also; offers services to our valuable customers. On the other hand, our Company has certified its already existing quality by establishing ISO 9001:2015 Quality Management System in 2004. Then the ISO14001:2015 Environmental Management System and OHSAS 18001:2007 Occupational Health Management and Number of the 21032019CE0075 and 21032019CE0076 are produced according to CE certification.

As of today, our Company has the honour of having the product variety (workpieces) above 3500 pcs types in Clamping and Processing equipment and also the reason of being the leader and producer company in own sector. Needless to say ,product variety is just only one side of our business. More importantly, it is to be able to achieve the consistency of DEPENDABILITY and QUALITY.

ER-EL has its ready stock for finished products consisting of above 3500 types. By giving importance to the value of time, our considers customer satisfaction important with its powerful stock.

Our project-based fixtures manufacturing outside of our standard production are also available. Especially in eminent companies in our industry; Defense & Aviation, Automotive, Appliances, Heavy Machinery and Weapons industry to have our fixture manufacturing industry.

ER-EL; as of today, exports to more than 24 countries, mainly Europe.

ER-EL that has moved to own new factory in 2017, continues its business activities with outstanding performance with dynamic and expert staff and have standard and project based solutions by being in compliance with the demands and continues to achieve customer satisfaction as its philosophy.

By taking this chance, we would like to thank you, our valuable customers, for your Trust in ER-EL and we reiterate our wishes for the continuation of our Cooperation in working together for many years to come...

Kind regards;
ER-EL Directors

index

<p>Nr. 0900 S. 13</p> 	<p>Nr. 0900 S. 14</p> 	<p>Nr. 0900 S. 15</p> 	<p>Nr. 0900 S. 16</p> 
<p>Nr. 0900 S. 17</p> 	<p>Nr. 0900 S. 18</p> 	<p>Nr. 0900 S. 18</p> 	<p>Nr. 0900 S. 19</p> 
<p>Nr. 0900 S. 20</p> 	<p>Nr. 0900 S. 20</p> 	<p>Nr. 0950 S. 21</p> 	<p>Nr. 0950 S. 22</p> 
<p>Nr. 0950 S. 23</p> 	<p>Nr. 0950 S. 24</p> 	<p>Nr. 0950 S. 24</p> 	<p>Nr. 0950 S. 24</p> 
<p>Nr. 0950 S. 25</p> 	<p>Nr. 0950 S. 25</p> 	<p>Nr. 1010 S. 30</p> 	<p>Nr. 1010 S. 31</p> 
<p>Nr. 1015 S. 32</p> 	<p>Nr. 1015 S. 33</p> 	<p>Nr. 1015 S. 34</p> 	<p>Nr. 1020 S. 36 S. 38 S. 40 S. 42 S. 44 S. 45</p> 
<p>Nr. 1022 S. 37 S. 39 S. 41 S. 43</p> 	<p>Nr. 1025 S. 47</p> 	<p>Nr. 1030 S. 48</p> 	<p>Nr. 1033 S. 49</p> 

index

<p>Nr. 1037 S. 50</p> 	<p>Nr. 1040 S. 51</p> 	<p>Nr. 1040 S. 51</p> 	<p>Nr. 1041 S. 51</p> 
<p>Nr. 1040 S. 52</p> 	<p>Nr. 1040 S. 52</p> 	<p>Nr. 1042 S. 52</p> 	<p>Nr. 1043 S. 55 Hydraulic</p> 
<p>Nr. 1045 S. 55 Hydraulic</p> 	<p>Nr. 1047 S. 56 Hydraulic</p> 	<p>Nr. 1050 S. 56 Hydraulic</p> 	<p>Nr. 1051 S. 57 Hydraulic</p> 
<p>Nr. 1052 S. 58 Hydraulic</p> 	<p>Nr. 1053 S. 59 Hydraulic</p> 	<p>Nr. 1055 S. 60 Hydraulic</p> 	<p>Nr. 1056 S. 61 Hydraulic</p> 
<p>Nr. 1056 S. 62 Hydraulic</p> 	<p>Nr. 1056 S. 62 Hydraulic</p> 	<p>Nr. 1057 S. 63 Hydraulic</p> 	<p>Nr. 1058 S. 65 Pneumatic</p> 
<p>Nr. 1058 S. 65 Pneumatic</p> 	<p>Nr. 1058 S. 66 Pneumatic</p> 	<p>Nr. 1058 S. 66 Pneumatic</p> 	<p>Nr. 1058 S. 67 Pneumatic</p> 
<p>Nr. 1060 S. 74</p> 	<p>Nr. 1065 S. 74</p> 	<p>Nr. 1067 S. 74</p> 	<p>Nr. 1120 T Nr. 1130 T Nr. 1150 T Nr. 1160 T S. 78 S. 79</p> 

index

<p>Nr. 1120 DT Nr. 1130 DT Nr. 1150 DT Nr. 1160 DT S. 80 S. 81</p> 	<p>Nr. 1120 M Nr. 1130 M Nr. 1150 M Nr. 1160 M S. 82 S. 83</p> 	<p>Nr. 1120 Nr. 1130 Nr. 1150 Nr. 1160 S. 84</p> 	<p>Nr. 1120 Nr. 1130 Nr. 1150 Nr. 1160 S. 84</p> 
<p>Nr. 1120 Nr. 1130 Nr. 1150 Nr. 1160 S. 84</p> 	<p>Nr. 1120 Nr. 1130 Nr. 1150 Nr. 1160 S. 85</p> 	<p>Nr. 1120 Nr. 1130 Nr. 1150 Nr. 1160 S. 85</p> 	<p>Nr. 1120 Nr. 1130 Nr. 1150 Nr. 1160 S. 86</p> 
<p>Nr. 1120 Nr. 1130 Nr. 1150 Nr. 1160 S. 86</p> 	<p>Nr. 1170 S. 87</p> 	<p>Nr. 1190 S. 87</p> 	<p>Nr. 1195 S. 88</p> 
<p>Nr. 1200 S. 90</p> 	<p>Nr. 1205 S. 90</p> 	<p>Nr. 1210 S. 91</p> 	<p>Nr. 1230 S. 91</p> 
<p>Nr. 1250 S. 92</p> 	<p>Nr. 1270 S. 92</p> 	<p>Nr. 1275 S. 93</p> 	<p>Nr. 1280 S. 93</p> 
<p>Nr. 1282 S. 94</p> 	<p>Nr. 1283 S. 94</p> 	<p>Nr. 1285 S. 94</p> 	<p>Nr. 1287 S. 96</p> 
<p>Nr. 1288 S. 97</p> 	<p>Nr. 1290 S. 98</p> 	<p>Nr. 1310 S. 98</p> 	<p>Nr. 1320 S. 98</p> 

index

Nr. 1330
S. 99



Nr. 1350
S. 99



Nr. 1370
S. 100



Nr. 1390
S. 100



Nr. 1387
S. 101



Nr. 1400
S. 101



Nr. 1410
S. 101



Nr. 1450
S. 102



Nr. 1470
S. 102



Nr. 1472
S. 103



Nr. 1473
S. 103



Nr. 1474
S. 104



Nr. 1475
S. 105



Nr. 1476
S. 105



Nr. 1477
S. 106



Nr. 1478
S. 106



Nr. 1479
S. 107



Nr. 1480
S. 108



Nr. 1481
S. 109



Nr. 1482
S. 110



Nr. 1483
S. 111



Nr. 1484
S. 112



Nr. 1485
S. 112



Nr. 1486
S. 113



Nr. 1486
S. 114



Nr. 1486
S. 115



Nr. 1486
S. 115































Nr. 1487
S. 116



index

<p>Nr. 1487 S. 117</p> 	<p>Nr. 1488 S. 118</p> 	<p>Nr. 1489 S. 119</p> 	<p>Nr. 1489 S. 119</p> 
<p>Nr. 1489 S. 120</p> 	<p>Nr. 1489 S. 121</p> 	<p>Nr. 1489 S. 121</p> 	<p>Nr. 1489 S. 122</p> 
<p>Nr. 1489 S. 123</p> 	<p>Nr. 1489 S. 123</p> 	<p>Nr. 1489 S. 124</p> 	<p>Nr. 1489 S. 124</p> 
<p>Nr. 1490 S. 126</p> 	<p>Nr. 1510 S. 126</p> 	<p>Nr. 1515 S. 127</p> 	<p>Nr. 1517 S. 127</p> 
<p>Nr. 1520 S. 127</p> 	<p>Nr. 1530 S. 128</p> 	<p>Nr. 1550 S. 128</p> 	<p>Nr. 1555 S. 129</p> 
<p>Nr. 1560 S. 129</p> 	<p>Nr. 1565 S. 129</p> 	<p>Nr. 1570 S. 129</p> 	<p>Nr. 1575 S. 129</p> 
<p>Nr. 1580 S. 130</p> 	<p>Nr. 1585 S. 130</p> 	<p>Nr. 1588 S. 131</p> 	<p>Nr. 1590 S. 134</p> 

index

<p>Nr. 1610 S. 135</p> 	<p>Nr. 1630 S. 136</p> 	<p>Nr. 1650 S. 137</p> 	<p>Nr. 1670 S. 137</p> 
<p>Nr. 1690 S. 138</p> 	<p>Nr. 1710 S. 140</p> 	<p>Nr. 1730 S. 140</p> 	<p>Nr. 1750 S. 141</p> 
<p>Nr. 1770 S. 141</p> 	<p>Nr. 1790 S. 142</p> 	<p>Nr. 1810 S. 142</p> 	<p>Nr. 1830 S. 142</p> 
<p>Nr. 1840 S. 143</p> 	<p>Nr. 1850 S. 143</p> 	<p>Nr. 1870 S. 143</p> 	<p>Nr. 1890 S. 144</p> 
<p>Nr. 1910 S. 144</p> 	<p>Nr. 1930 S. 144</p> 	<p>Nr. 1950 S. 145</p> 	<p>Nr. 1955 S. 145</p> 
<p>Nr. 1960 S. 146</p> 	<p>Nr. 1970 S. 146</p> 	<p>Nr. 1990 S. 148</p> 	<p>Nr. 2010 S. 149</p> 
<p>Nr. 2020 S. 150</p> 	<p>Nr. 2020 S. 150</p> 	<p>Nr. 2020 S. 150</p> 	<p>Nr. 2030 S. 152</p> 

index

Nr. 2050
S. 153



Nr. 2070
S. 154



Nr. 2072
S. 155



Nr. 2073
S. 155



Nr. 2077
S. 156



Nr. 2080
S. 156



Nr. 2090
S. 157



Nr. 2095
S. 158



Nr. 2095
S. 158



Nr. 2098
S. 159



Nr. 2098
S. 159



Nr. 2110
S. 160



Nr. 2120
S. 160



Nr. 2130
S. 160



Nr. 2135
S. 161



Nr. 2137
S. 161



Nr. 2139
S. 162



Nr. 2141
S. 163



Nr. 2143
S. 163



Nr. 2144
S. 164



Nr. 2150
S. 165



Nr. 2170
S. 165



Nr. 2190
S. 166



Nr. 2210
S. 166



Nr. 2230
S. 167



Nr. 2250
S. 167



Nr. 2270
S. 168



Nr. 2290
S. 168



index

<p>Nr. 2295 S. 169</p> 	<p>Nr. 2297 S. 169</p> 	<p>Nr. 2300 S. 171</p> 	<p>Nr. 2305 S. 172</p> 
<p>Nr. 2307 S. 172</p> 	<p>Nr. 2310 S. 174</p> 	<p>Nr. 2315 S. 175</p> 	<p>Nr. 2310 S. 176</p> 
<p>Nr. 2310 S. 177</p> 	<p>Nr. 2310 S. 178</p> 	<p>Nr. 2320 S. 179</p> 	<p>Nr. 2330 S. 180</p> 
<p>Nr. 2345 S. 181</p> 	<p>Nr. 2333 Nr. 2334 Nr. 2335 Nr. 2336 Nr. 2340 S. 182</p> 	<p>Nr. 2330 S. 183</p> 	<p>Nr. 2345 S. 184</p> 
<p>Nr. 2350 S. 185</p> 	<p>Nr. 2370 S. 185</p> 	<p>Nr. 2375 S. 186</p> 	<p>Nr. 2385 S. 188</p> 
<p>Nr. 2390 S. 189</p> 	<p>Nr. 2410 S. 190</p> 	<p>Nr. 2415 S. 190</p> 	<p>Nr. 2420 S. 190</p> 
<p>Nr. 2430 S. 192</p> 	<p>Nr. 2435 S. 193</p> 	<p>Nr. 2430 S. 194</p> 	<p>Nr. 2430 S. 194</p> 

index

<p>Nr. 2430 S. 195</p> 	<p>Nr. 2430 S. 195</p> 	<p>Nr. 2440 S. 197</p> 	<p>Nr. 2443 S. 198</p> 
<p>Nr. 2445 S. 199</p> 	<p>Nr. 2443 S. 200</p> 	<p>Nr. 2443 S. 200</p> 	<p>Nr. 2443 S. 201</p> 
<p>Nr. 2443 S. 201</p> 	<p>Nr. 2445 S. 202</p> 	<p>Nr. 2450 S. 205</p> 	<p>Nr. 2470 S. 205</p> 
<p>Nr. 2475 S. 206</p> 	<p>Nr. 2480 S. 206</p> 	<p>Nr. 2481 S. 207</p> 	<p>Nr. 2482 S. 208</p> 
<p>Nr. 2483 S. 208</p> 	<p>Nr. 2490 S. 211</p> 	<p>Nr. 2510 S. 211</p> 	<p>Nr. 2530 S. 212</p> 
<p>Nr. 2550 S. 212</p> 	<p>Nr. 2557 S. 214</p> 	<p>Nr. 2560 S. 214</p> 	<p>Nr. 2563 S. 214</p> 
<p>Nr. 2565 S. 215</p> 	<p>Nr. 2567 S. 215</p> 	<p>Nr. 2570 S. 217</p> 	<p>Nr. 2590 S. 217</p> 

index

<p>Nr. 2600 S. 218</p> 	<p>Nr. 2610 S. 219</p> 	<p>Nr. 2630 S. 219</p> 	<p>Nr. 2650 S. 220</p> 
<p>Nr. 2670 S. 221</p> 	<p>Nr. 2690 S. 221</p> 	<p>Nr. 2710 S. 222</p> 	<p>Nr. 2730 S. 223</p> 
<p>Nr. 2750 S. 223</p> 	<p>Nr. 2770 S. 224</p> 	<p>Nr. 2790 S. 224</p> 	<p>Spezial – Spannelemente Special Fixtures S. 225 - 226</p>
<p>Spezial-Projektanwendungen Create A Special Order Template S. 227</p>	<p>Anwendung Richtig-Falsch Right - Wrong Use S. 228 - 230</p>	<p>Werkzeug-Schnellwechsel-System Quick Die Change System Form S. 231 - 232</p>	

Referenz-Nr. Order No.	Technische Daten / Specifications	
0900-UL800.010	Durchmesser: 80mm Höhe: 75mm Haltekraft (M10): 3500 kgf Haltekraft (M12): 5000 kgf Wiederholgenauigkeit: <0.005 mm Gewicht: 3.65 kg	Diameter: 80mm Height: 75mm Retention force (M10): 3500 kgf Retention force (M12): 5000 kgf Repeatability: <0.005 mm Weight: 3.65 kg
0900-UL800.012	Durchmesser: 80mm Höhe: 100mm Haltekraft (M10): 3500 kgf Haltekraft (M12): 5000 kgf Wiederholgenauigkeit: <0.005 mm Gewicht: 4.55 kg	Diameter: 80mm Height: 100mm Retention force (M10): 3500 kgf Retention force (M12): 5000 kgf Repeatability: <0.005 mm Weight: 4.45 kg



0900

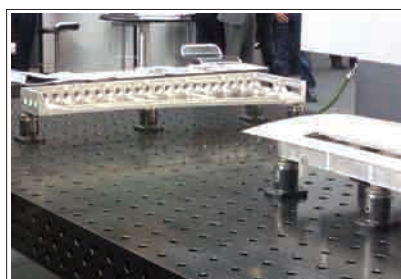
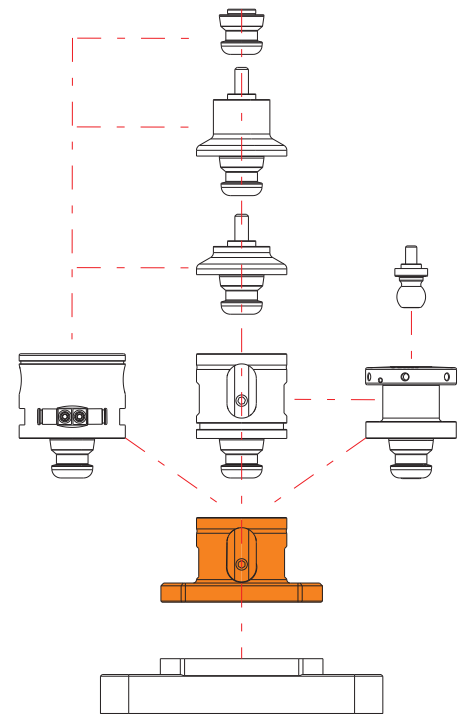
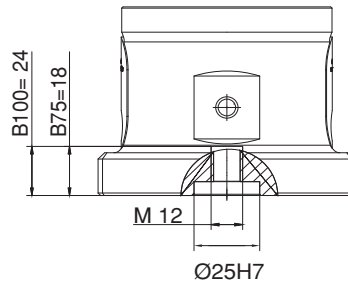
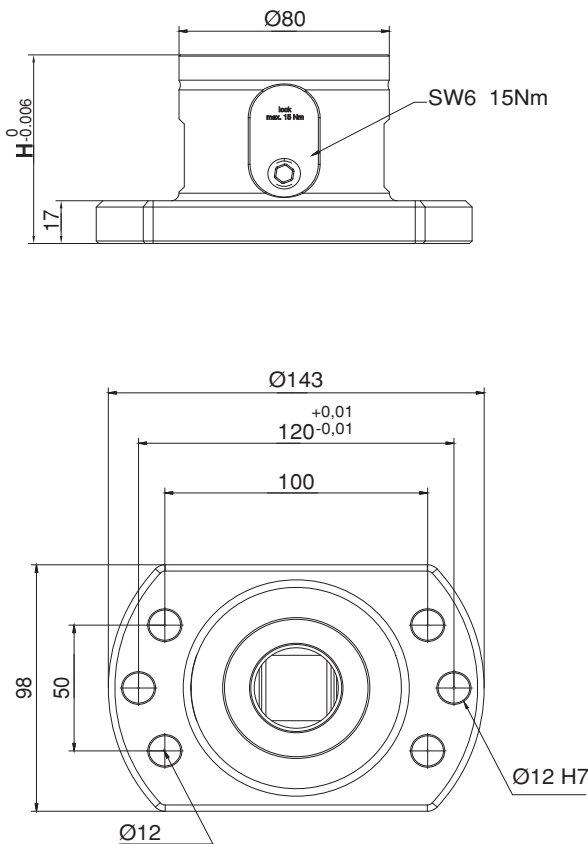

Referenz-Nr. Order No.	Technische Daten / Specifications	
0900-UL800.018	Durchmesser: 80mm Höhe (H): 125 mm Haltekraft (M10): 3500 kgf Haltekraft (M12): 5000 kgf Wiederholgenauigkeit: <0.005 mm Gewicht: 6.65 kg	Diameter: 80mm Height (H): 125mm Retention force (M10): 3500 kgf Retention force (M12): 5000 kgf Repeatability: <0.005 mm Weight: 6.65 kg
0900-UL800.019	Durchmesser: 80mm Höhe (H): 150 mm Haltekraft (M10): 3500 kgf Haltekraft (M12): 5000 kgf Wiederholgenauigkeit: <0.005 mm Gewicht: 7.60 kg	Diameter: 80mm Height (H): 150mm Retention force (M10): 3500 kgf Retention force (M12): 5000 kgf Repeatability: <0.005 mm Weight: 7.60 kg
0900-UL800.020	Durchmesser: 80mm Höhe (H): 175 mm Haltekraft (M10): 3500 kgf Haltekraft (M12): 5000 kgf Wiederholgenauigkeit: <0.005 mm Gewicht: 8.45 kg	Diameter: 80mm Height (H): 175mm Retention force (M10): 3500 kgf Retention force (M12): 5000 kgf Repeatability: <0.005 mm Weight: 8.45 kg



0900

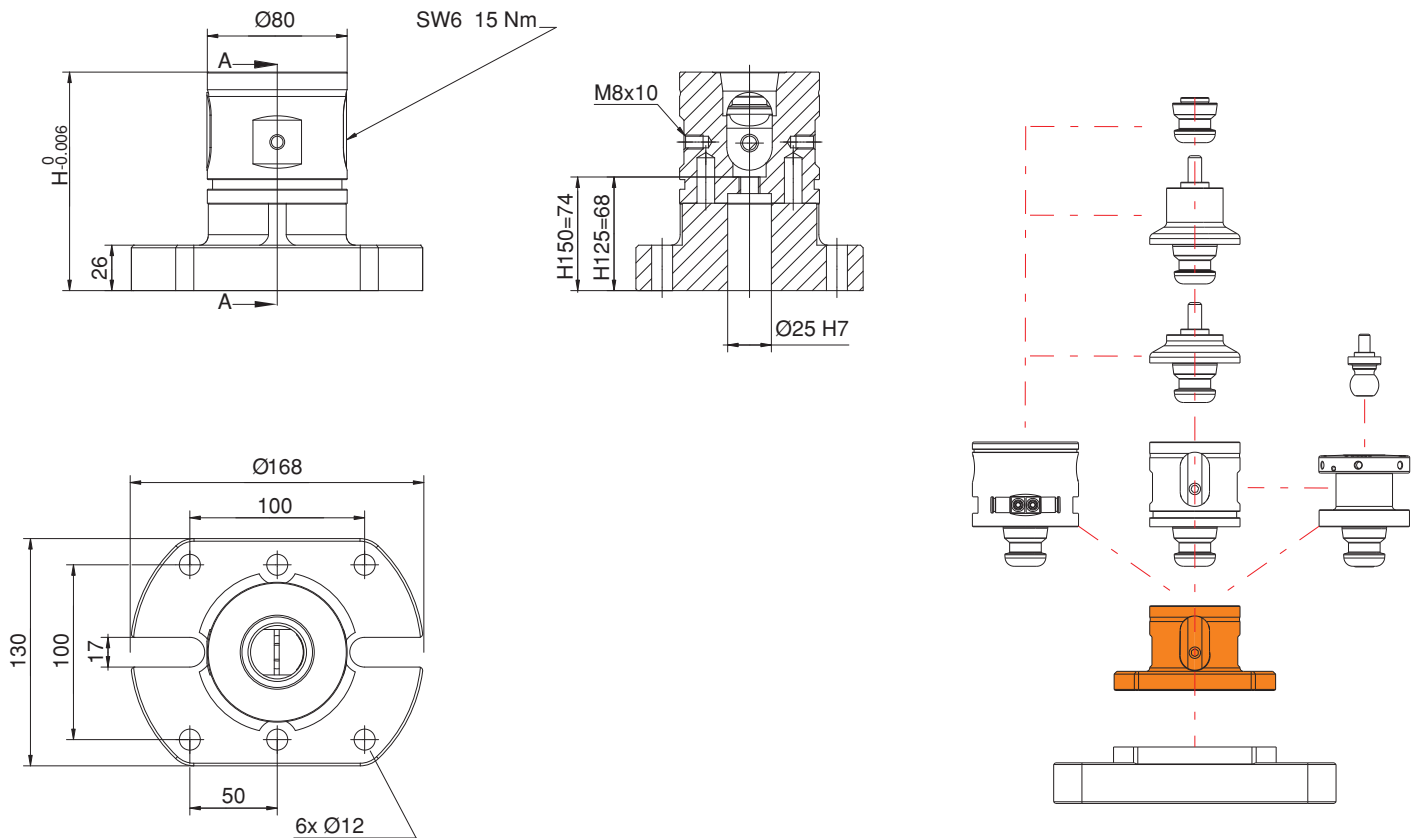

Referenz-Nr. Order No.	Technische Daten / Specifications	
0900-UL800.030	Durchmesser: 80mm Höhe (H): 75 mm Haltekraft (M10): 3500 kgf Haltekraft (M12): 5000 kgf Wiederholgenauigkeit: <0.005 mm Gewicht: 2.85 kg	Diameter: 80mm Height (H): 75mm Retention force (M10): 3500 kgf Retention force (M12): 5000 kgf Repeatability: <0.005 mm Weight: 2.85 kg
0900-UL800.031	Durchmesser: 80mm Höhe (H): 100 mm Haltekraft (M10): 3500 kgf Haltekraft (M12): 5000 kgf Wiederholgenauigkeit: <0.005 mm Gewicht: 3.65 kg	Diameter: 80mm Height (H): 100mm Retention force (M10): 3500 kgf Retention force (M12): 5000 kgf Repeatability: <0.005 mm Weight: 3.65 kg
0900-UL800.032	Durchmesser: 80mm Höhe (H): 125 mm Haltekraft (M10): 3500 kgf Haltekraft (M12): 5000 kgf Wiederholgenauigkeit: <0.005 mm Gewicht: 4.70 kg	Diameter: 80mm Height (H): 125mm Retention force (M10): 3500 kgf Retention force (M12): 5000 kgf Repeatability: <0.005 mm Weight: 4.70 kg



0900

- Anwendungshöhe: 75mm, 100 mm, 125mm
- Ermöglicht die Verwendung von bis zu 1m Aufrüstung.

0900

- 75mm, 100mm and 125 mm in height can be used.
- Allows the use of up to 1m upgrade.

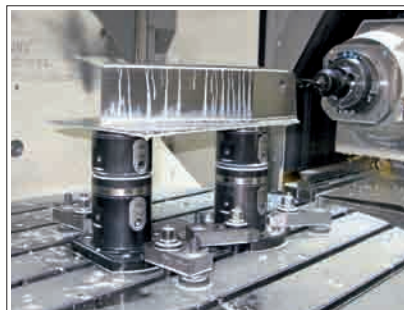
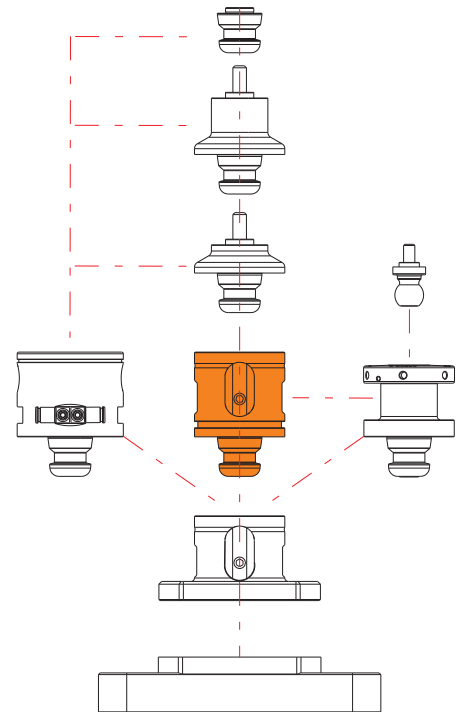
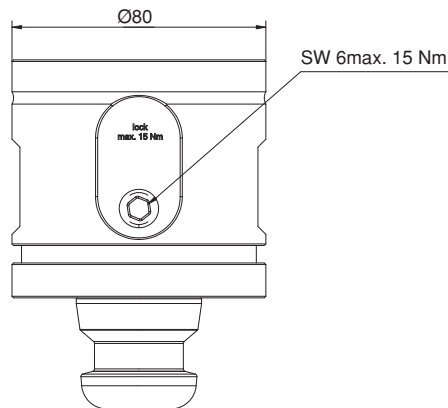
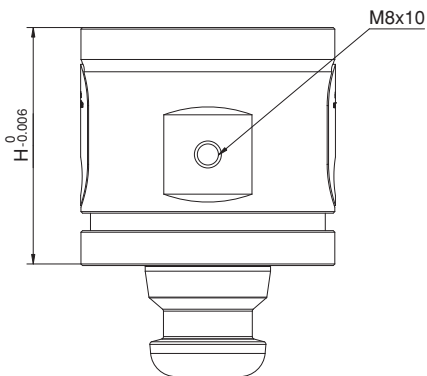
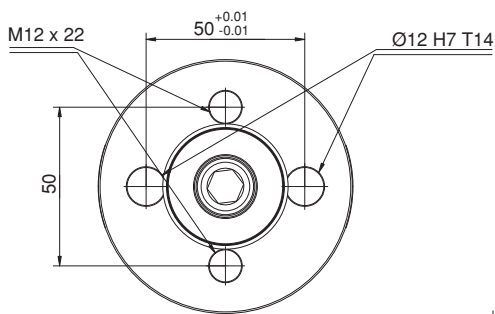

Referenz-Nr. Order No.	Technische Daten / Specifications	
0900-UL800.033	Durchmesser: 80mm Höhe (H): 75 mm Haltekraft (M10): 3500 kgf Haltekraft (M12): 5000 kgf Wiederholgenauigkeit: <0.005 mm Gewicht: 3.30 kg	Diameter: 80mm Height: 75mm Retention force (M10): 3500 kgf Retention force (M12): 5000 kgf Repeatability: <0.005 mm Weight: 3.30 kg



0900
pneumatisches Öffnen und Schließen bei Massenproduktion

0900
• Pneumatic opening and closing at mass production

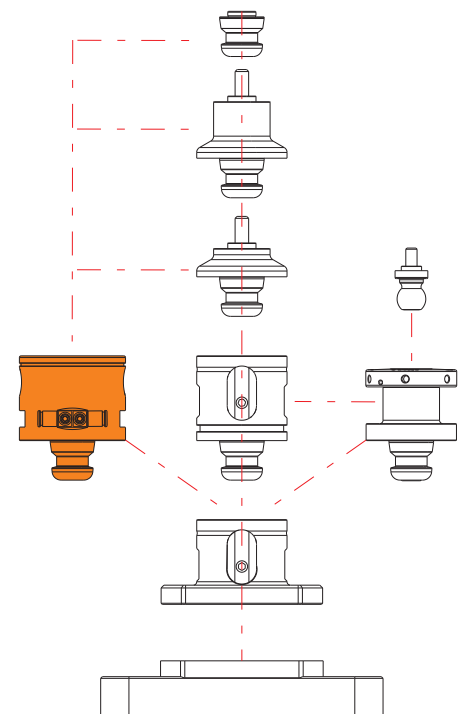
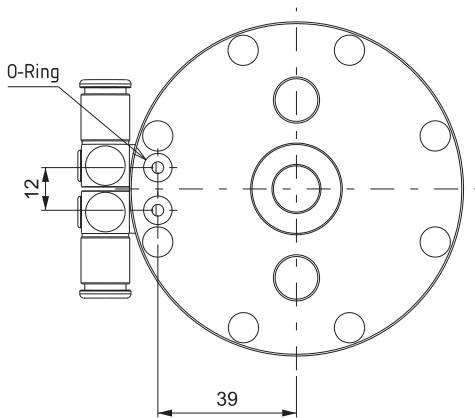
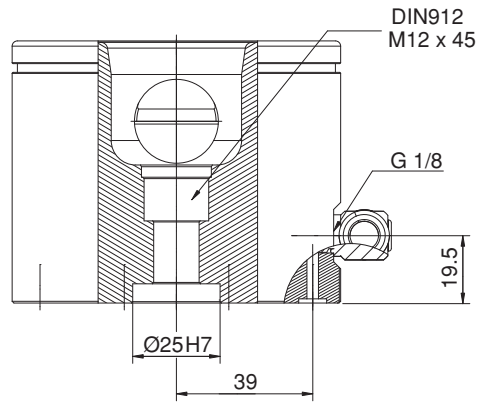
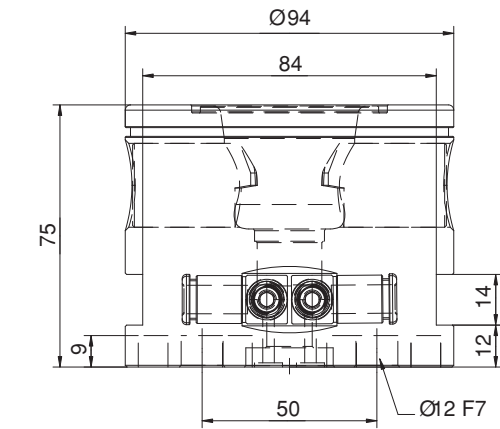

Referenz-Nr. Order No.	Technische Daten / Specifications	
0900-UL800.055	Höhe (H): 50 mm Länge: 250mm Breite: 270mm Gewicht: 14.20 kg	Height (H): 50mm Length: 250mm Width: 270mm Weight: 14.20 kg
0900-UL800.056	Höhe (H): 100 mm Länge: 250mm Breite: 270mm Gewicht: 18.70 kg	Height (H): 100mm Length: 250mm Width: 270mm Weight: 18.70 kg
0900-UL800.057	Höhe (H): 150 mm Länge: 250mm Breite: 270mm Gewicht: 21.20 kg	Height (H): 150mm Length: 250mm Width: 270mm Weight: 21.20 kg

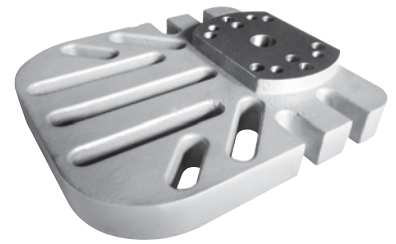

0900

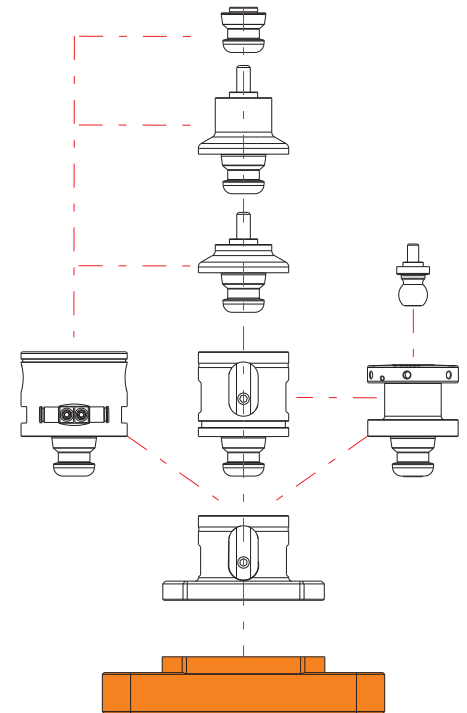
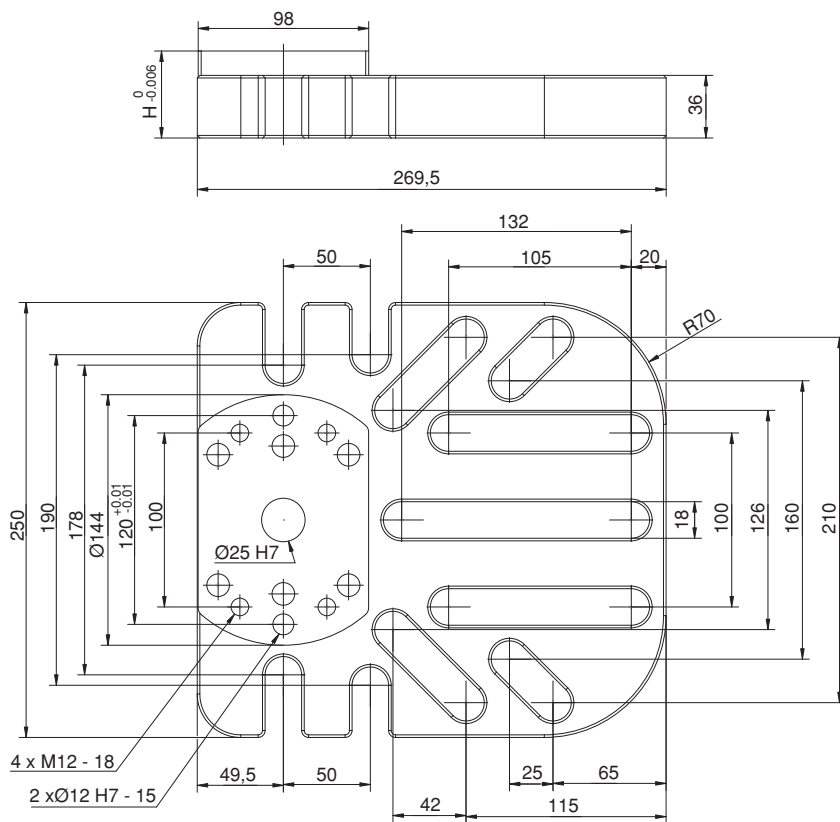

Referenz-Nr. Order No.	Technische Daten / Specifications	
0900-UL800.126	1x SBC 40-25-5-16, 1x Befestigungsschraube M12x100mm Gewicht: 0.875 kg	1x SBC 40-25-5-16, 1x mounting screw M12x100mm Weight: 0.875 kg
0900-UL800.123	1x SBC 40-25-5-16, 1x Befestigungsschraube M12x75mm Gewicht: 0.875 kg	1x SBC 40-25-5-16, 1x mounting screw M12x75mm Weight: 0.875 kg
0900-UL800.120	1x SBC 40-25-5-12, 1x Befestigungsschraube M10x100mm Gewicht: 0.875 kg	1x SBC 40-25-5-12, 1x mounting screw M10x100mm Weight: 0.875 kg
0900-UL800.117	1x SBC 40-25-5-12, 1x Befestigungsschraube M10x75mm Gewicht: 0.875 kg	1x SBC 40-25-5-12, 1x mounting screw M10x75mm Weight: 0.875 kg



0900

- Um Deformationen des Werkstücks zu verhindern.

0900

- To prevent deformations of the workpiece.

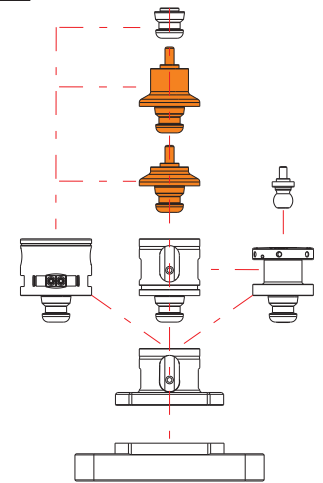
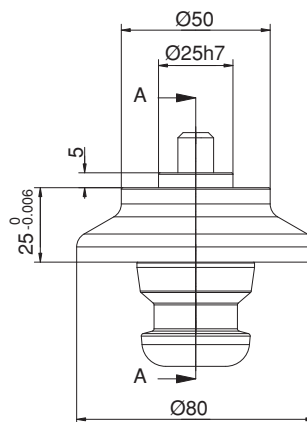
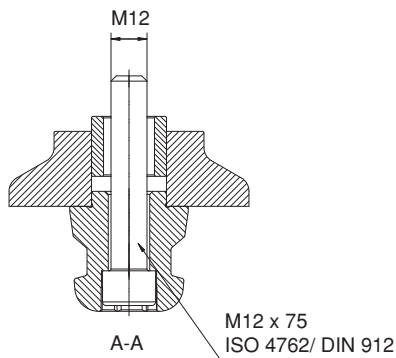

5-Achs Reduktion inkl.

Referenz-Nr. Order No.	Technische Daten / Specifications	
0900-UL800.111	1x SBC 40-25-5-16, 1x Befestigungsschraube M12x100mm Gewicht: 1.180 kg	1x SBC 40-25-5-16, 1x mounting screw M12x100mm Weight: 1.180 kg
0900-UL800.108	1x SBC 40-25-5-16, 1x Befestigungsschraube M12x75mm Gewicht: 1.180 kg	1x SBC 40-25-5-16, 1x mounting screw M12x75mm Weight: 1.180 kg
0900-UL800.105	1x SBC 40-25-5-16, 1x Befestigungsschraube M10x100mm Gewicht: 1.180 kg	1x SBC 40-25-5-12, 1x mounting screw M10x100mm Weight: 1.180 kg
0900-UL800.102	1x SBC 40-25-5-16, 1x Befestigungsschraube M10x75mm Gewicht: 1.180 kg	1x SBC 40-25-5-12, 1x mounting screw M10x75mm Weight: 1.180 kg





0900

- Um eine Änderung der Wechselgenauigkeit zu verhindern.

0900

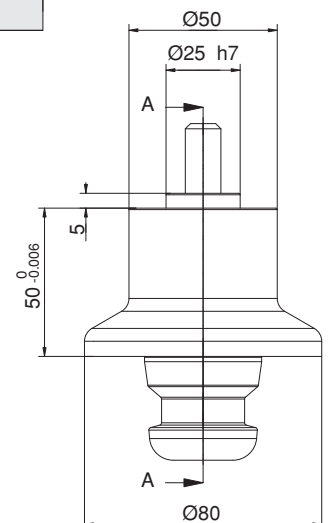
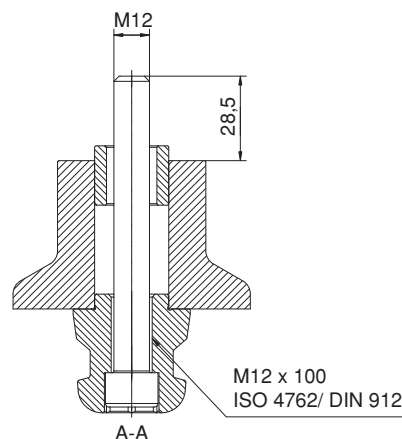
- To prevent change of repeating precision.



Referenz-Nr. Order No.	Spezifikationen Description	L x ØD	Ød	L1	m	 (kg)
0900-UL500.115	SBC	40	25h6	5	12	0.200
0900-UL500.118	SBC	40	25h6	5	16	0.200
0900-UL500.121	SBC	40	25h6	5	20	0.200



0900

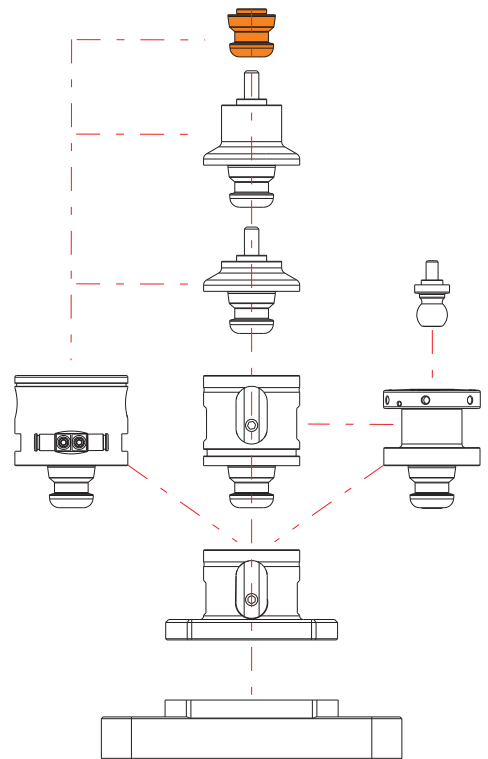
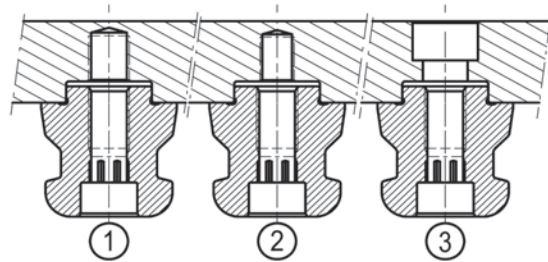
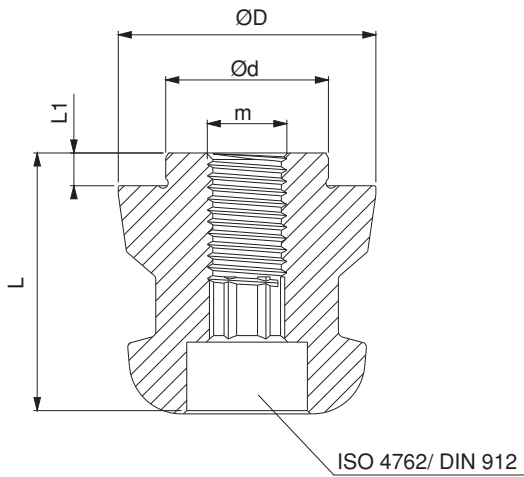

Referenz-Nr. Order No.	Technische Daten / Specifications	
0900-UL800.360	Durchmesser: 80mm Höhe : 63.50 mm Haltekraft (M10): 3500 kgf Haltekraft (M12): 5000 kgf Wiederholgenauigkeit: <math><0.005\text{ mm}</math> Gewicht: 1.90 kg	Diameter: 80 mm Height: 63.50 mm Retention force (M10): 3500 kgf Retention force (M12): 5000 kgf Repeatability: <math><0.005\text{ mm}</math> Weight: 1.90 kg

0900

- Ermöglicht Werkstücke mit bis zu 15° Schräge zu klemmen.
- Mindestens drei Klemmstellen auf dem Werkstück sind erforderlich.

0900

- Enables to clamp inclined workpieces with up to 15°
- At least three clamping points on the workpiece are required.

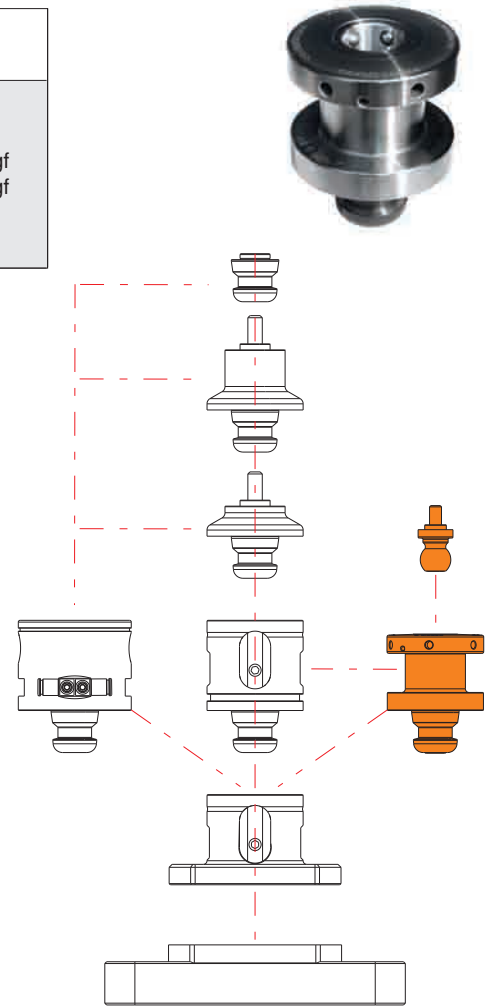
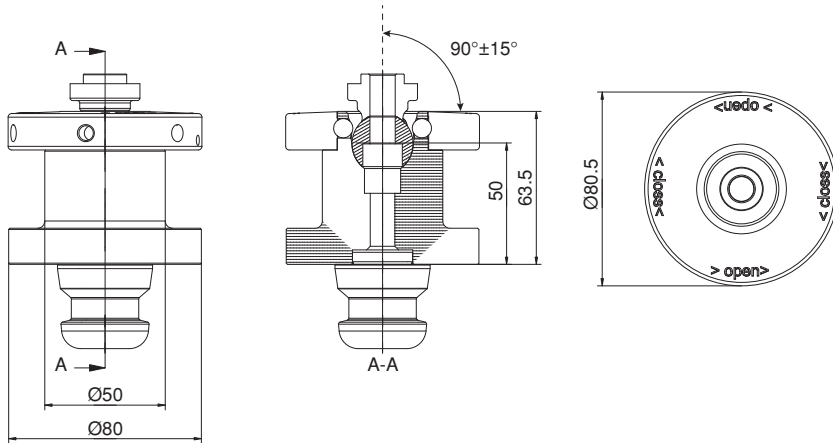

5-Achs FLEX Spannkugel inkl.

Referenz-Nr. Order No.	Technische Daten / Specifications	
0900-UL800.382	Kugeldurchmesser: 25,4 mm inkl. Zentrierungsdeckel 15° Ausgleichsbereich Gewicht: 0,10 kg	Diameter head / head diameter: 25.4 mm included centering cover 15° working weight: 0.10 kg

0900

- 15° maximaler Winkelabstand

0900

- 15° maximum angular space

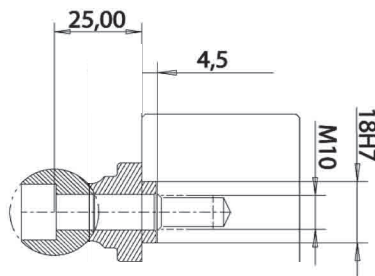

Referenz-Nr. Order No.	D	H (±0.01)	D1	L	H1	H2	W	H3	d	P	W1	Spannkraft Clamping Force Kgf	zulässiges Drehmoment Allowable Screw Torque (N-m)	(g)
0950-08040	40	40	22	46	20	20	65	10	9	50	4	800	8	300
0950-12063	60	63	32	69	33	30	95	15	13	75	6	1500	22	1400



0950

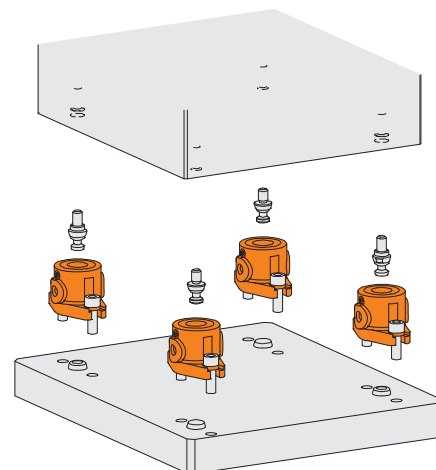
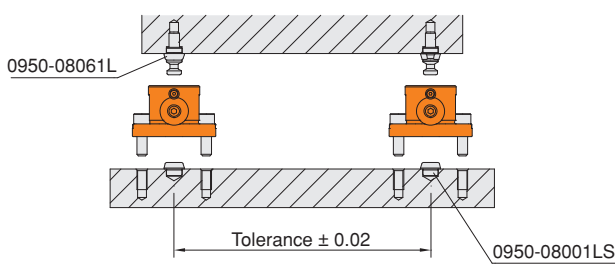
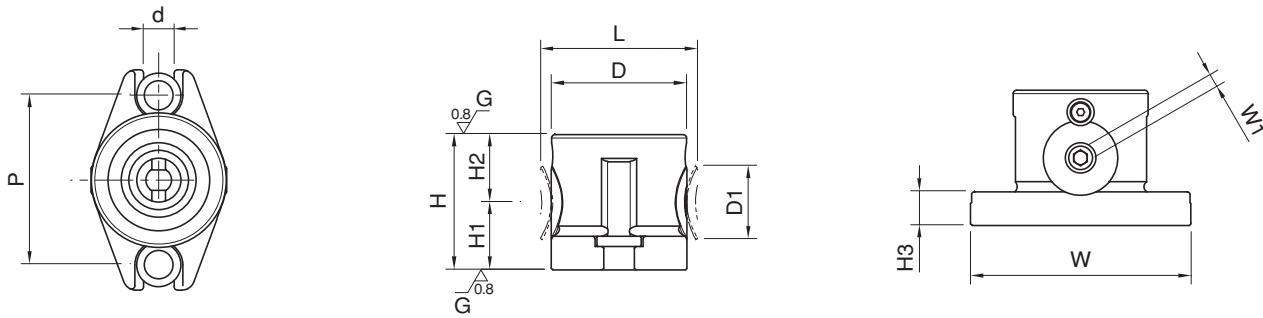

Anwendungsbeispiel / Application Examples

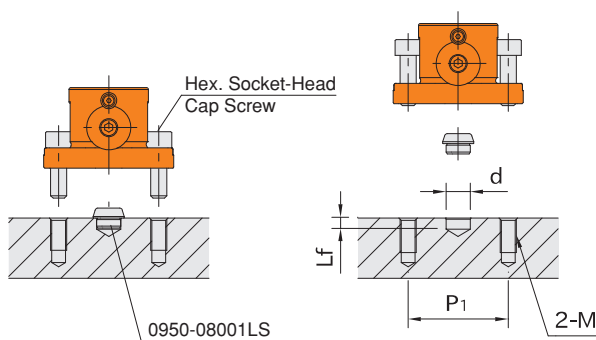

Referenz-Nr. Order No.	d (H7)	Lf	M	P1
0950-08040	40	40	M8	20
0950-12063	60	63	M12	30

Referenz-Nr. Order No.	D	H (±0.01)	D1	L	H1	H2	H3	d (H7)	H4	M	W	Spannkraft Clamping Force Kgf	zulässiges Drehmoment Allowable Screw Torque (N-m)	(g)
0950-08050	40	50	22	46	30	20	18	40	7.5	M8	4	800	8	500
0950-12080	60	80	32	69	50	30	25	60	10.5	M12	6	1500	22	1600



0950

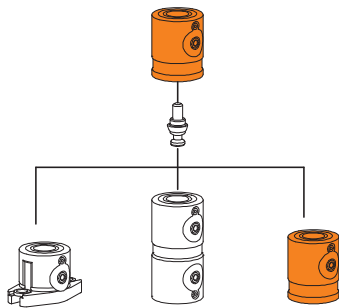
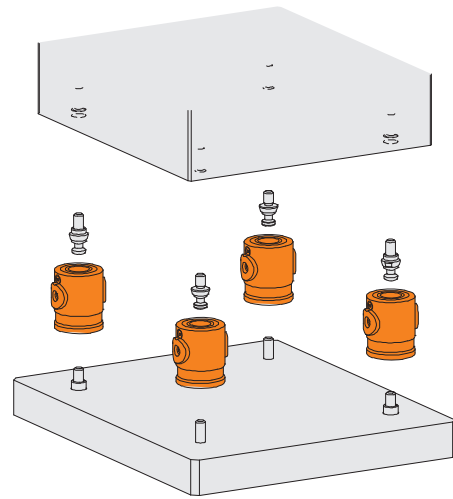
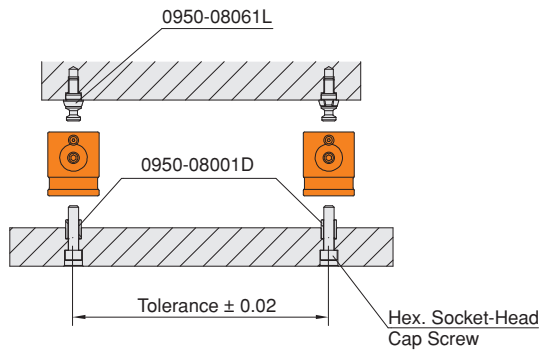
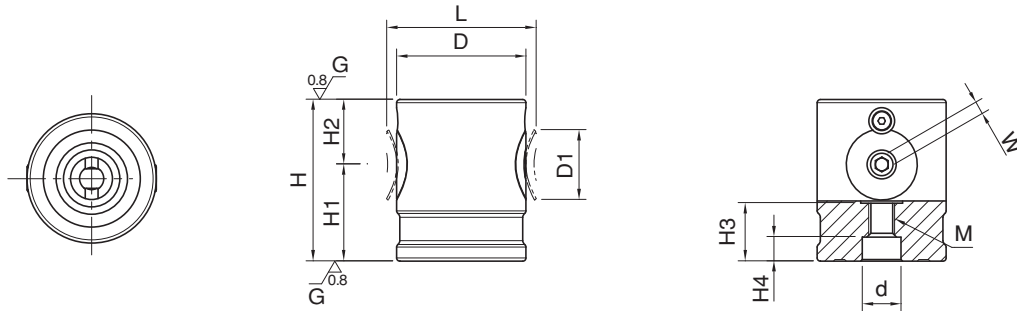

Anwendungsbeispiel / Application Examples

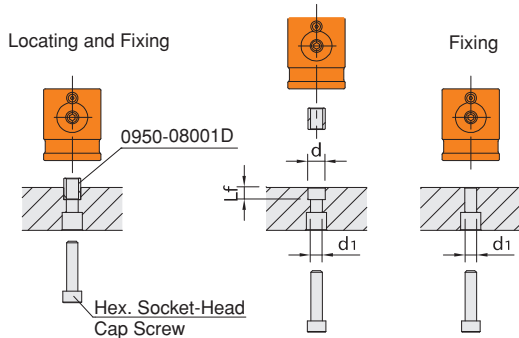

Referenz-Nr. Order No.	d (H7)	Lf	d1 (+0.2 0)
0950-08050	12	8.5	12
0950-12080	18	12.5	18

Referenz-Nr. Order No.	D	H (±0.01)	D1	L	H1	W	Spannkraft Clamping Force KgF	zulässiges Drehmoment Allowable Screw Torque (N-m)	 (g)
0950-08080	40	80	22	46	20	4	800	8	700
0950-12125	60	125	32	69	30	6	1500	22	2600



0950

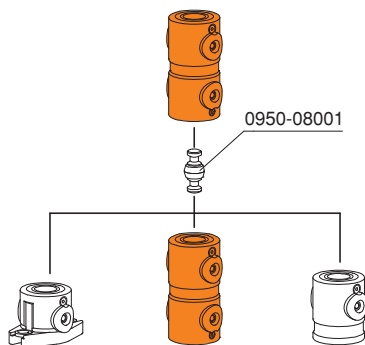
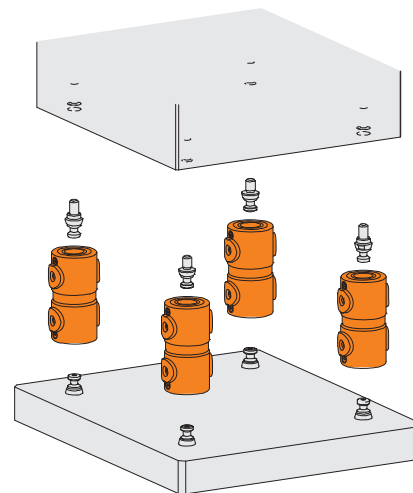
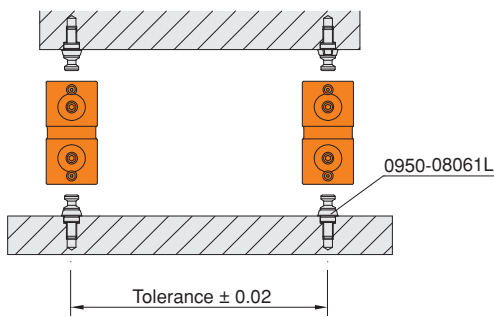
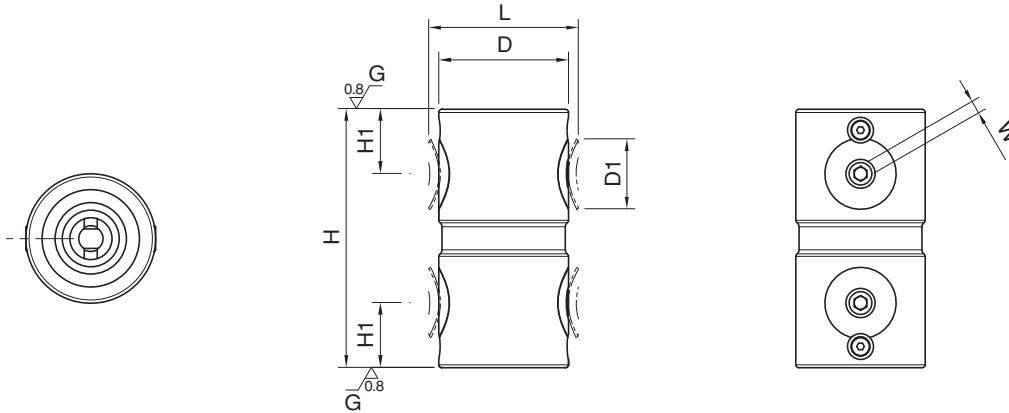

Anwendungsbeispiel / Application Examples

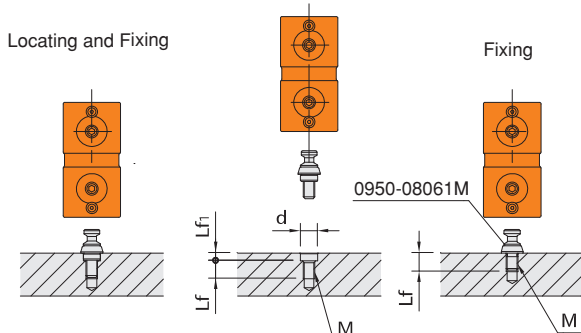

Referenz-Nr. Order No.	d (H7)	Lf	Lf1	M
0950-08080	12	13	5.5	8
0950-12125	18	19	6.5	12

Referenz-Nr. Order No.	M	D1 (g6)	L2	L1	D	L	D2	D3	W	
0950-08061L	M6	10	5	17	15.5	16.5	11	6.5	3	17
0950-08000L	M8	12	5	17	15.5	16.5	11	6.5	3	20
0950-12081L	M8	12	5	17	24.5	25	16	9.5	5	52
0950-12001L	M12	18	6	24	24.5	25	16	9.5	5	70

0950

• Toleranz ±0.02

0950

• Tolerance ± 0.02

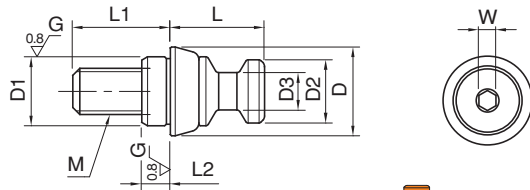
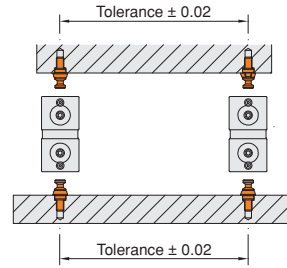

**Anwendungsbeispiel
Application Examples**

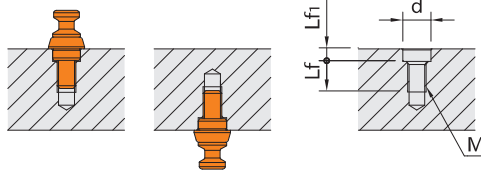

Referenz-Nr. Order No.	d (H7)	Lf	Lf1	M
0950-08061L	10	13	5.5	M6
0950-08000L	12	13	5.5	M8
0950-12081L	12	13	5.5	M8
0950-12001L	18	19	6.5	M12

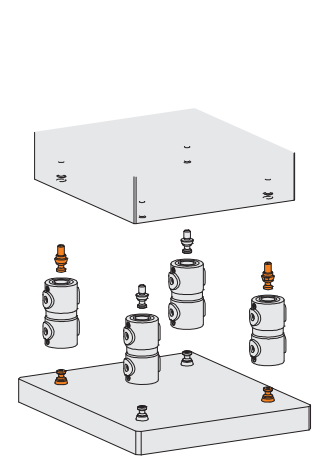

Referenz-Nr. Order No.	M	L1	D	L	D1	D2	W	
0950-08061M	M6	9	15	16.5	11	6.5	3	13
0950-08001M	M8	12	15	16.5	11	6.5	3	16
0950-12081M	M8	12	24	25	16	9.5	5	46
0950-12001M	M12	18	24	25	16	9.5	5	57

0950

• Toleranz ±0.2

0950

• Tolerance ±0.2

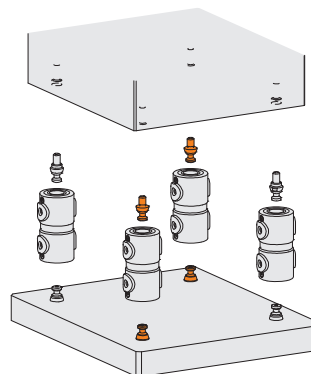
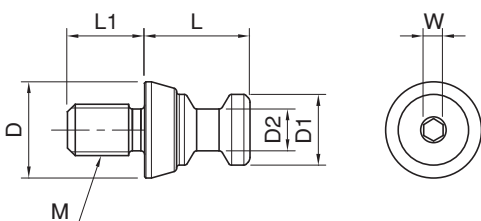

Spannbolzen

5-Axis Clamping Block Puller Bolt

Referenz-Nr. Order No.	D	L	D1	D2	L1	
0950-08001	15.5	33	11	6.5	16.5	24
0950-12001	24.5	50	16	9.5	25	85

0950

• Wiederholungsgenauigkeit 0,2

0950

• Locating Repeatability is 0.2

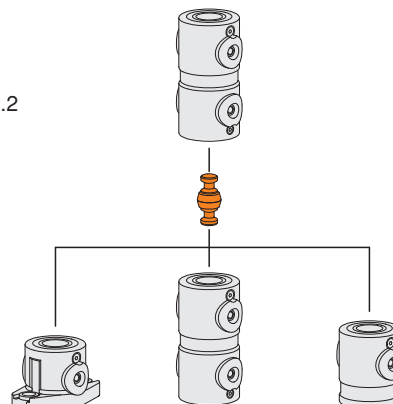
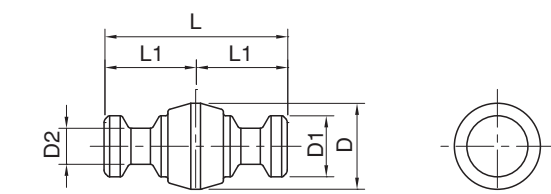

Spannbolzen

5-Axis Clamping Block Puller Bolt

Referenz-Nr. Order No.	d	D (h6)	H	(kg)
0950-08001D	8.5	12	15	7
0950-12001D	12.5	18	22	22

0950

• Toleranz ± 0.2

0950

• Tolerance ± 0.02

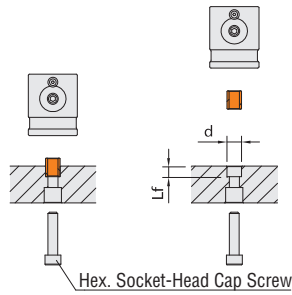
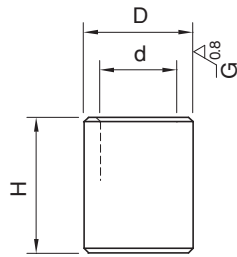

Referenz-Nr. Order No.	d (H7)	Lf
0950-08001D	12	8.5
0950-12001D	18	12.5

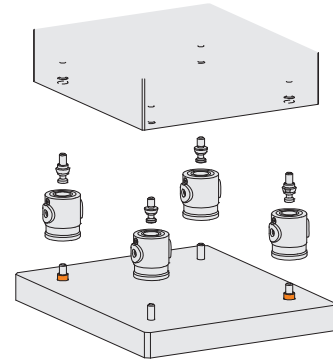
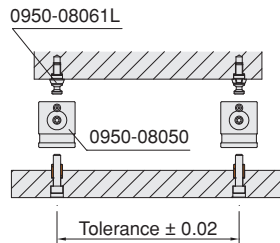

Referenz-Nr. Order No.	D	H	D1	H1	d	(g)	
0950-08001LS	15.5	10	12	g6	5	8	6
0950-12001LS	24.5	12	18	g6	6	12	24
0950-08001SM	15.5	12	12	-0.02	5	-	11
0950-12001SM	24.5	18	18	-0.05	6	-	37

0950

• Geschliffene Toleranz ± 0.02
• Standard-Toleranz $^{+0.1}_0$

0950

• Stoning Tolerans ± 0.02
• Standard Tolerance $^{+0.1}_0$

Klemmblock Lokalisierungsbuchse

5-Axis Clamping Block Locating Bushings



LS
Stoning
Tolerance ± 0.02



SM
Standard
Tolerance $^{+0.1}_0$

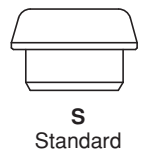
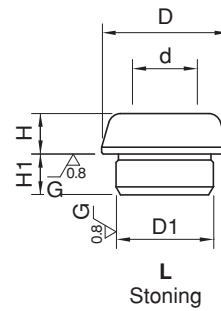

Anwendungsbeispiel / Application Examples

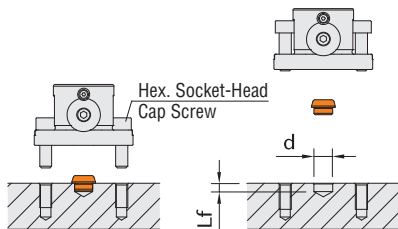

Referenz-Nr. Order No.	d (H7)	Lf
0950-08001LS	12	5.5
0950-12001LS	18	6.5

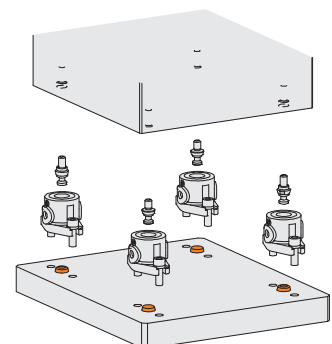
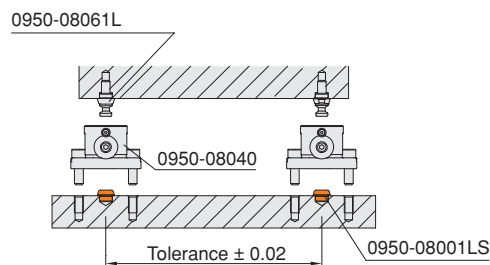

Werkzeug-Schnellwechselsystem

Quick Mold Change System

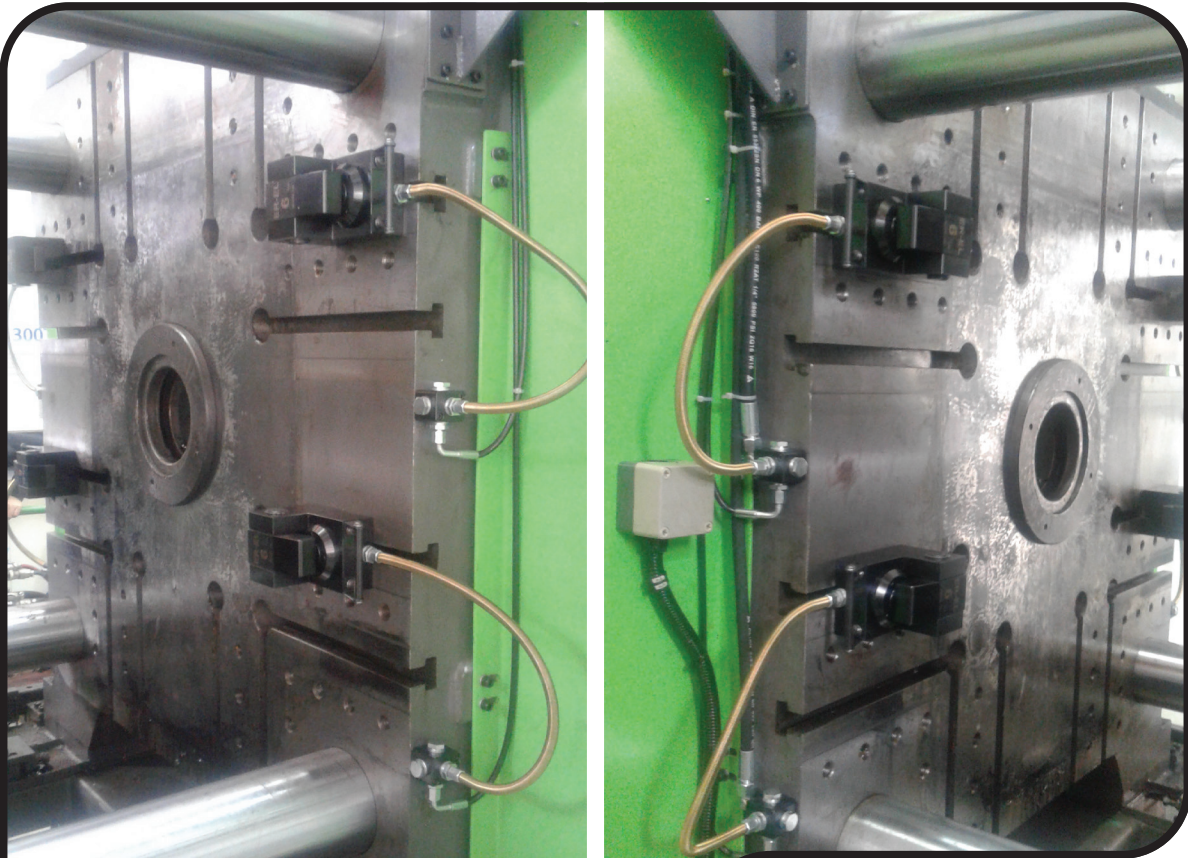

Werkzeug-Schnellwechselsystem
Quick Mold Change System

Werkzeug-Schnellwechselsystem
Quick Die Change System

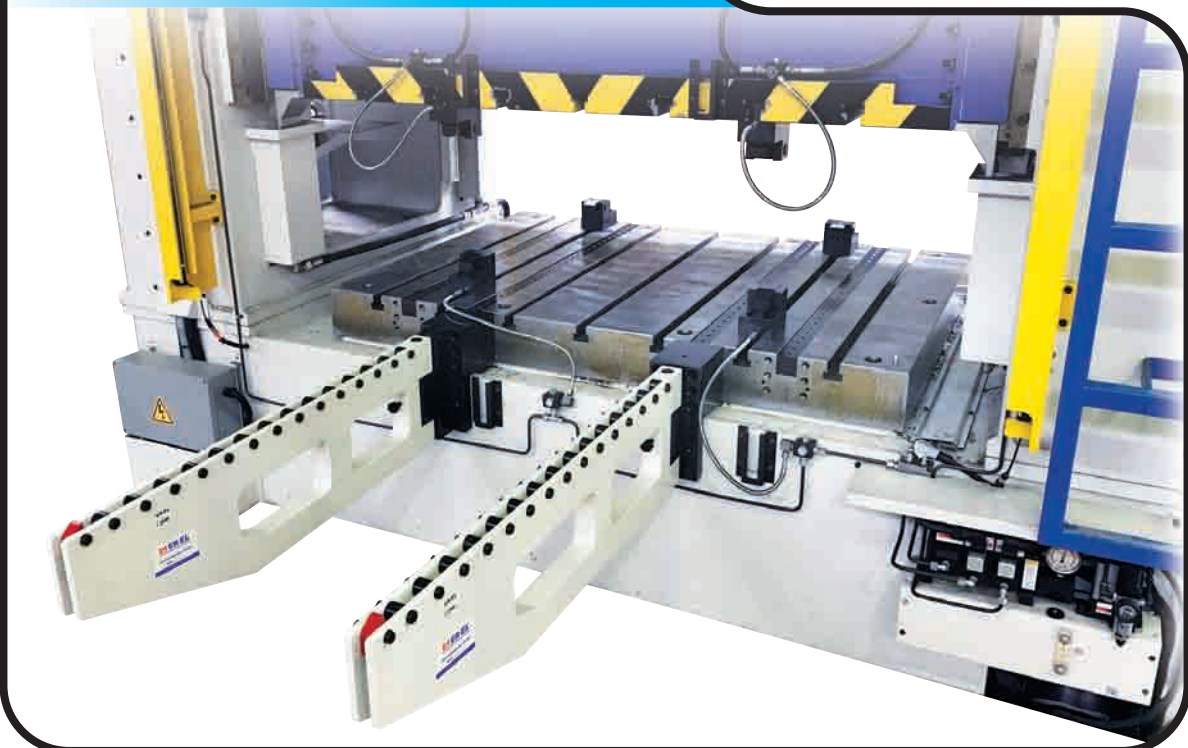
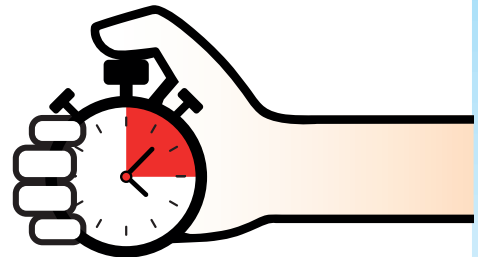

Werkzeug-Schnellwechselsystem

Wenn Werkzeuge schneller gewechselt werden müssen, weil es verschiedene Anfragen und weniger Stückzahlen gibt, ist es Zeit auf das schnelle Schnellwechselsystem zu wechseln.

Anwendung

- Pressen und hydraulische - Spritzguss
- unterschiedliche automatische Maschinen

Application

- Press - hydraulic press - injection
- Different automatic machine clamp system

Quick Die Change System

It's an era for making high frequency of die changing with multiple patterns and small quantity. In order to save die changing time and ensure operational safety, it is just in time to apply Quick Die Change System.

Elektronische Bediensäule Electronic Control Operation Panel

- mit Verriegelungssteuerung ausgestattet.
- It is equipped with interlock control switch for connecting to the machine.
- mit Sicherheitschalter zur Vermeidung von Betriebsfehler.
- It is designed with safety control device which prevents any operation error.

Werkzeugheber / Die Lifter

Modell / Model: DL - DB - DLS - DBS

- Hydraulisch oder gefedert.
- Hydraulic type, spring type.
- Befestigung in T-Nut oder U-Nut.
- Install in the T-slot or U-slot.



Werkzeugschiebearm / Die Arm

Modell / Model: RC - RD - RE/RF - RS

- auf Maschinentisch leicht schiebbar.
- Can pull out and push in the die from the plate easily.
- 4 unterschiedlich Werkzeugarm – Modelle,
- There are 4 different models of die arm.

Hydraulische Luftdruck-Pumpeneinheit Air Driven Hydraulic Pump Unit

- Geeignet für die Druckprüfung und Verriegelung mit Maschinen.
- Capable of pressure inspection and interlocking with machines.
- Die Bewegungen zwischen den einzelnen Geräten werden gegenseitig festgelegt, um die Betriebssicherheit zu gewährleisten.
- The movements between each device will be pinned down mutually in order to ensure operational safety.

Werkzeugspanner / Die Clamp

Model : CA - CV - CB - CC

- ersetzt konventionelle Methoden.
- Replacing the traditional method which uses screws to fix dies.
- Einsatz bei Maschinen mit T-Nut-Tisch.
- Using T-slots to lock or fix directly on the plate.

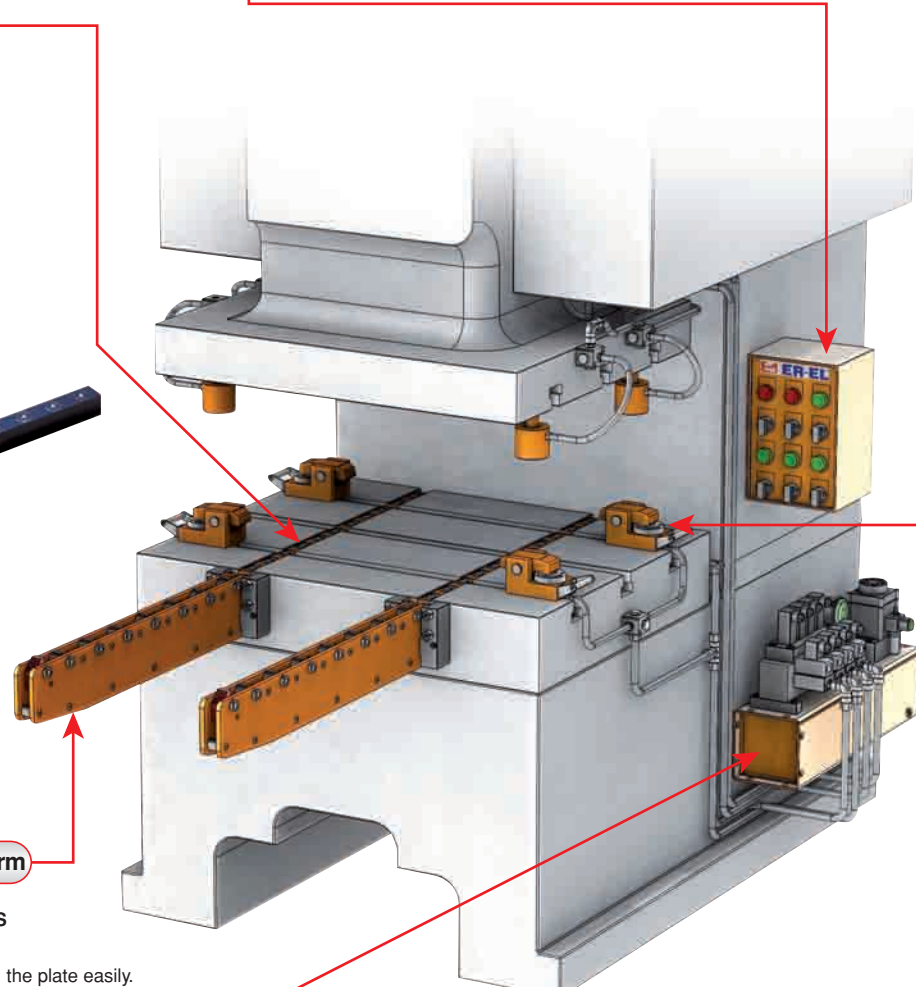

Werkzeug-Schnellwechselsystem (Pressendiagramm)

Quick Die Change System (Diagram for Press Machine)

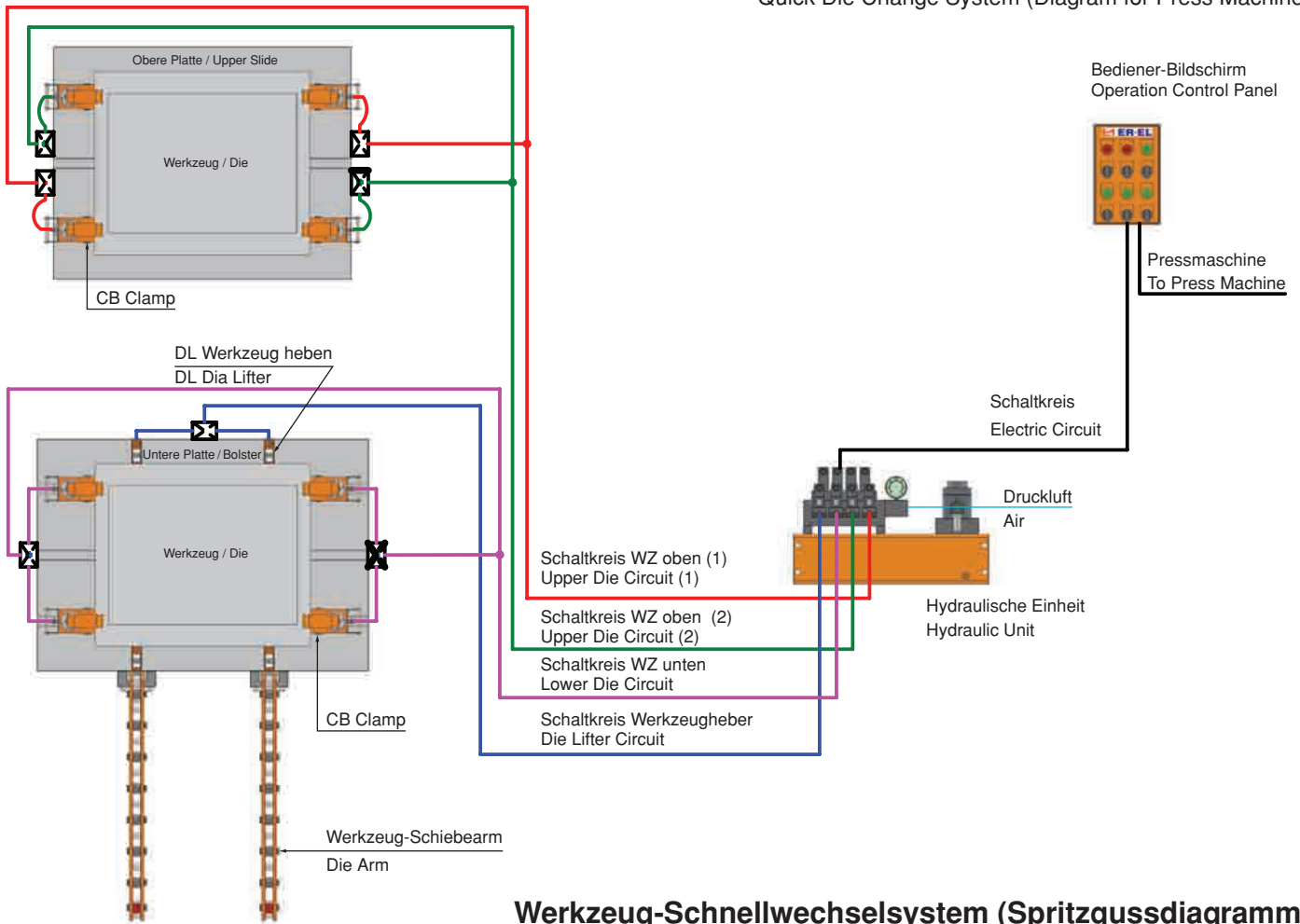

Werkzeug-Schnellwechselsystem (Spritzgussdiagramm)

Quick Mold Change System (Diagram for Injection Machine)

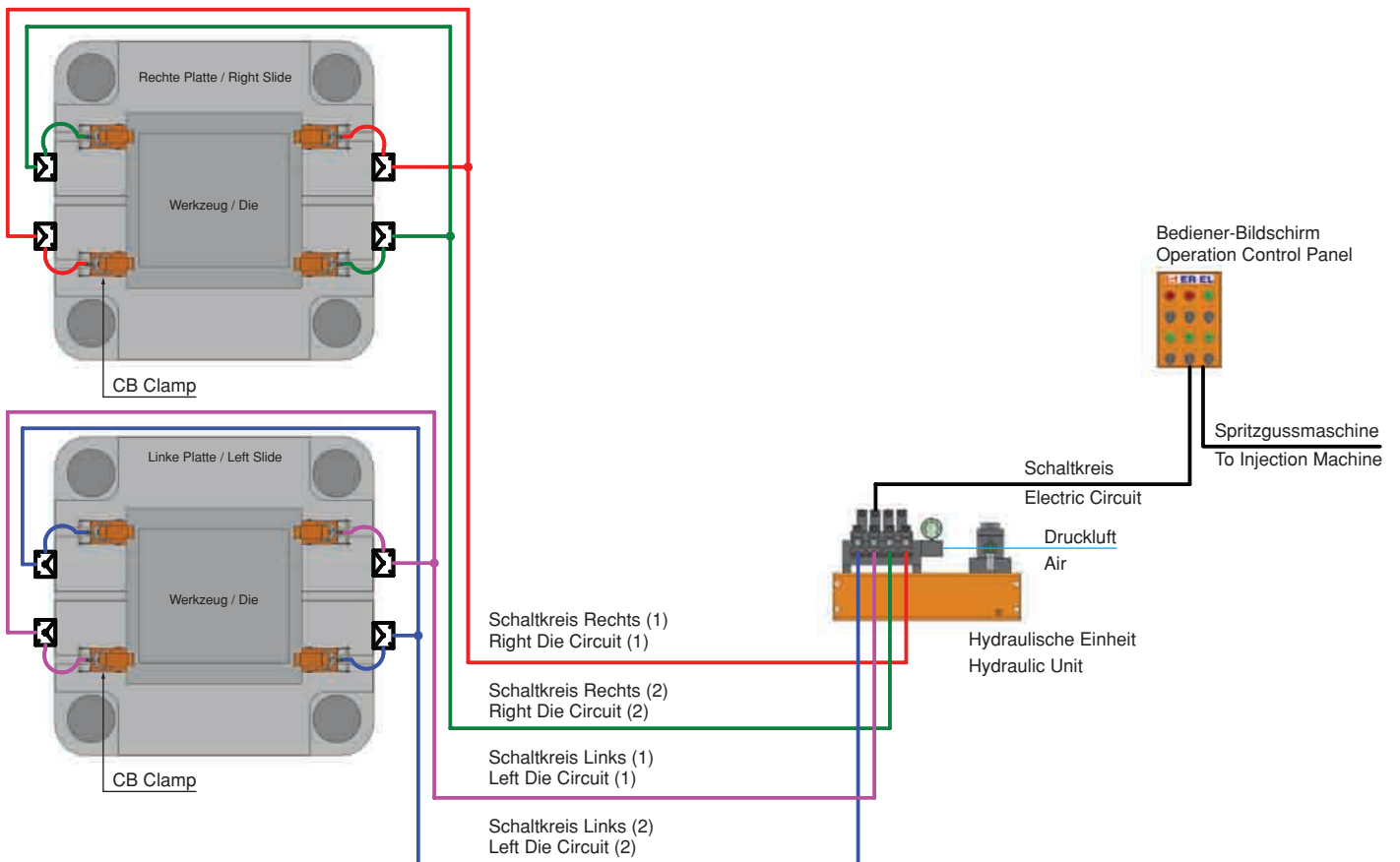

Einlegen des Werkzeugs

Beladen Sie das Werkzeug mit einem Kran oder Gabelstapler.
Die Werkzeugschieber ermöglichen eine einfache Beladung.

Load the die

Load the die using a crane or forklift.
The pre-rollers enable easy loading.

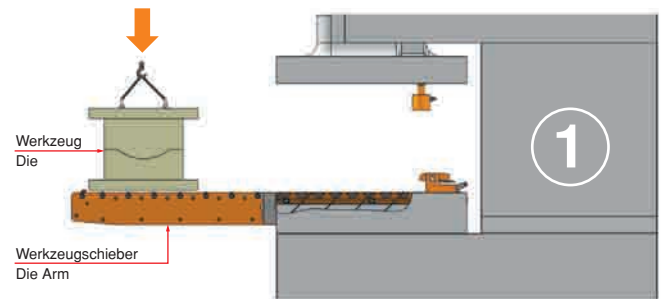

Schieben Sie das Werkzeug auf die untere Platte.

Durch den Werkzeugheber und Werkzeugschiebern ist zum Bewegen des Werkzeugs nur minimale Kraft erforderlich.
Die Werkzeugheber werden in den T- / U-Nuten eingebaut.
Werkzeugheber: Hydraulikdruck **ON**

Transfer the die to the bolster.

With the pre-rollers and die lifters, minimal force is required to move the die.
The lifters are set in the T- / U-slots.
Die Lifter : Hydraulic pressure **ON**

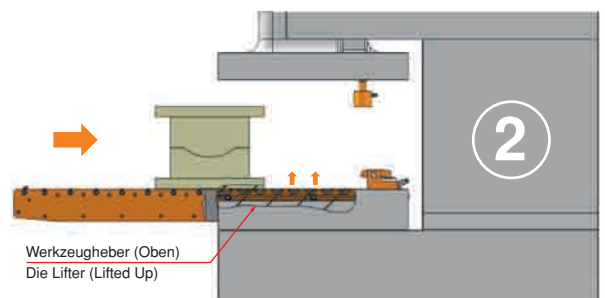

Setzen Sie das Werkzeug auf die Platte.

Bei Drucktastenbedienung wird der Werkzeugheber gesenkt und das Werkzeug berührt die Platte.
Werkzeugheber: Hydraulikdruck **OFF**

Set the die on the bolster.

With push-button operation, the die lifter releases and the die makes contact with the bolster.
Die Lifter : Hydraulic Pressure **OFF**

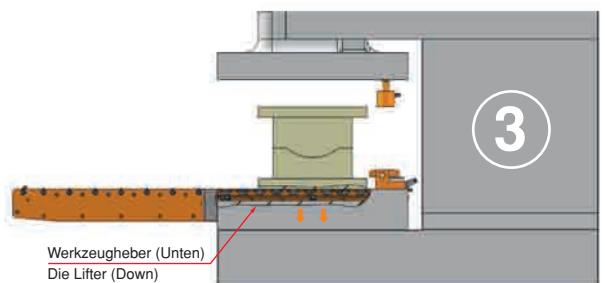

Platzieren Sie die hydraulischen Spannelemente .

Platzieren Sie die hydraulischen Spannelemente dem Werkzeug entsprechend ein.
Schieben Sie die hydraulischen Spannelemente in den T-Nuten und bringen Sie sie in die Nähe des Werkzeugs.
Hydraulische Spannelemente: Hydraulikdruck **OFF**

Set the automatic clamps.

Set the slide to the bottom dead center .
Slide automatic clamps on the T-slot and bring them near the die.
Hydraulic Clamp : Hydraulic Pressure **OFF**

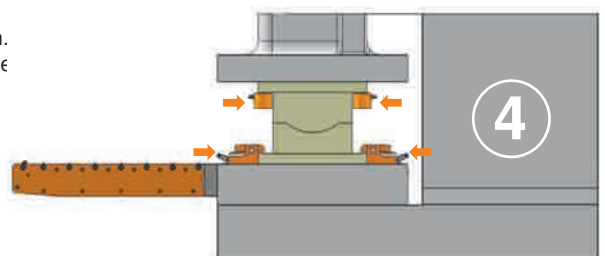

Spannen Sie das Werkzeug.

Bei Drucktastenbedienung werden die Spannelemente gespannt.
Nach der Sicherheitsüberprüfung kann der Werkzeugschieber entfernt werden.
Hydraulische Spannelemente: Hydraulikdruck **ON**

Lock the die.

With push-button operation, automatic clamps lock the die.
After safety confirmation, the pre-roller can be removed.
Hydraulic Clamp : Hydraulic Pressure **ON**

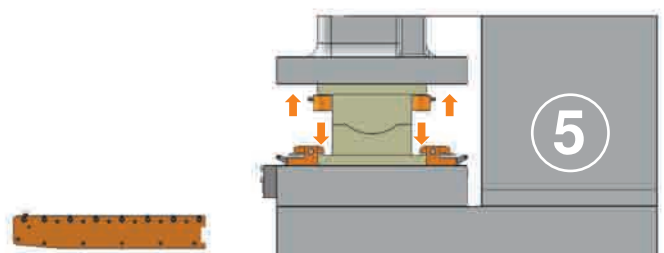

Modell / Model		CA-1	CA-2	CA-4	CA-6	CA-10	CA-16	CA-25
Spannkapazität Capacity of clamp	Ton	1	2	4	6	10	16	25
Total-Hub (X) Total stroke (X)	mm	6	8	8	8	8	8	8
Spannhub (Y) Stroke of clamp (Y)	mm	3	4	4	4	4	4	4
Schonhub (Z) Preserved stroke (Z)	mm	3	4	4	4	4	4	4
Zylinder-Gesamtvolumen Total volumn of cylinder	cc	3	7	13	21	32	54	76
Toleranzen Werkzeugunerteil-Dicke (H) The tolerance of the template thickness (H)	mm	±1.5	±2	±2	±2	±2	±2	±2

Hydraulischer Druck / Hydraulic pressure : 250kg/cm²



- Bei Bestellung bitte T-Nut-Größe (a,b,c,d) und Werkzeugunterteil-Dicke (H) angeben.
- Please indicate the size of T-slot (a,b,c,d) and the thickness (H) of the template for the die when purchasing.

Referenz-Nr. Order No.	ØF	E	ØG	ØJ	H+d max.	L max.	a min.	K	P
1010-CA01	44	48	12	30	60	12	8	9.5	PT1/8
1010-CA02	53	52	16	48	80	17	12	12	PT1/8
1010-CA04	65	58	23	58	90	20	16	15	PT1/4
1010-CA06	82	65	30	64	100	25	18	15	PT1/4
1010-CA10	99	71	38	78	110	30	22	15	PT1/4
1010-CA16	126	82	45	88	120	38	28	17	PT1/4
1010-CA25	150	100	55	98	140	45	36	23	PT1/4

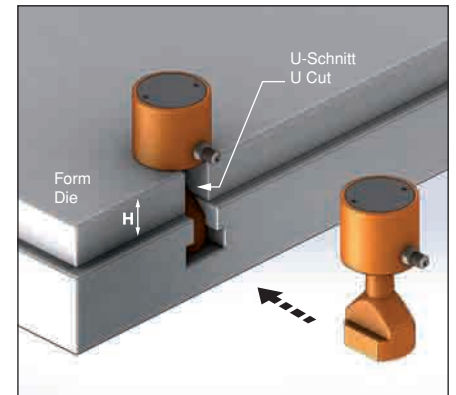

1010

- Spannmaße A, B und C werden in T-Nut gespannt festgelegt.
- Wenn Spannmaß (H+d) höher als obige Werte ist, wird dies als Sonderkonstruktion bewertet.
- Temperatur Standard : 60°

1010

- The sizes of clamps (A),(B) and (C) are made based on the size of T slot.
- If the thickness of clamp (H+d) is more than the max. value listed on the left, it will be regarded as special pattern.
- Standard Temperature : 60°

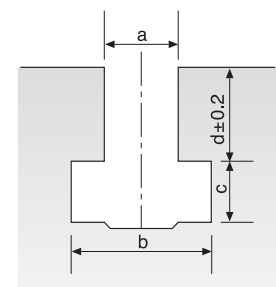
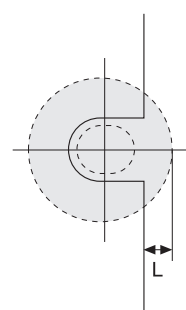
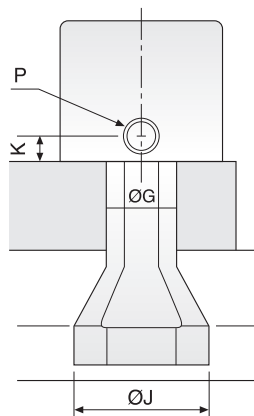
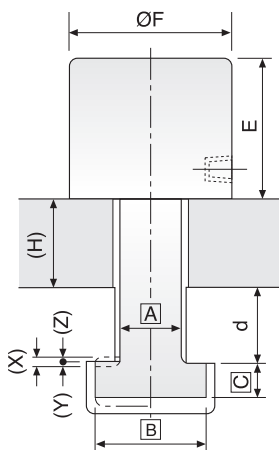

L: Länge Schablone zum Spannen
L: Template's length for clamp

Modell / Model		CV-4	CV-6	CV-10
Spannkapazität Capacity of clamp	Ton	4	6	10
Total-Hub (X) Total stroke (X)	mm	8	8	8
Spannhub (Y) Stroke of clamp (Y)	mm	4	4	4
Schonhub (Z) Preserved stroke (Z)	mm	4	4	4
Zylinder-Gesamtvolumen Total volumn of cylinder	cc	13	21	32
Toleranzen Werkzeugunerteil-Dicke (H) The tolerance of the template thickness (H)	mm	±2	±2	±2

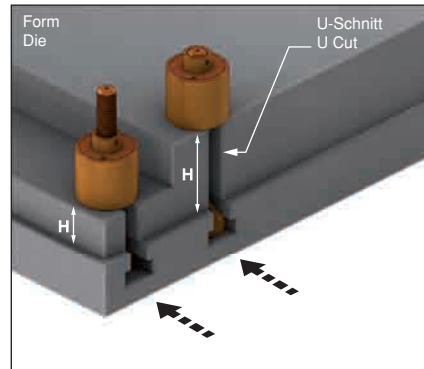

Hydraulischer Druck / Hydraulic pressure : 250kg/cm²

Referenz-Nr. Order No.		A	B	C	D	E + K1	Einstellidistanz adjust distance	F	Max. L	M	ØG	ØJ	K	P
1010-CV042020125	20	19.6	32	12	85	70	15	65	125	M20	20	58	15	PT 1/4
1010-CV042020160	20	19.6	32	12	110	70	40	65	160	M20	20	58	15	PT 1/4
1010-CV042022160	22	21.6	35	14	85	70	15	65	125	M20	20	58	15	PT 1/4
1010-CV042022125	22	21.6	35	14	110	70	40	65	160	M20	20	58	15	PT 1/4
1010-CV062424125	24	23.6	40	16	85	77	8	82	125	M24	24	64	15	PT 1/4
1010-CV062424160	24	23.6	40	16	110	77	33	82	160	M24	24	64	15	PT 1/4
1010-CV062428125	28	27.6	44	18	85	77	8	82	125	M24	24	64	15	PT 1/4
1010-CV062428160	28	27.6	44	18	110	77	33	82	160	M24	24	64	15	PT 1/4
1010-CV102727160	27	26.6	46	18	110	83	27	99	160	M27	27	78	15	PT 1/4
1010-CV102727200	27	26.6	46	18	125	83	42	99	200	M27	27	78	15	PT 1/4
1010-CV102732160	32	31.6	50	20	110	83	27	99	160	M27	27	78	15	PT 1/4
1010-CV102732200	32	31.6	50	20	125	83	42	99	200	M27	27	78	15	PT 1/4

1010

- Schraubenabstandseinstellung kann vorgenommen werden.
- Temperatur Standard : 60°

1010

- Screw-distance adjustment can be made.
- Standard Temperature : 60°

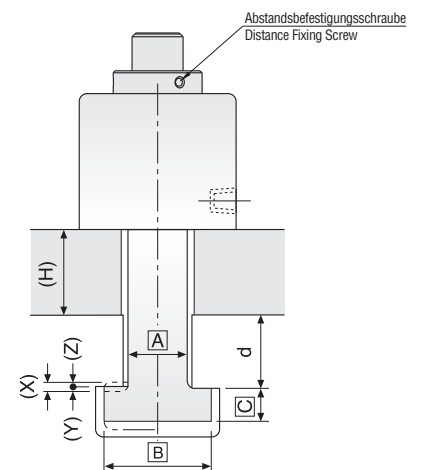
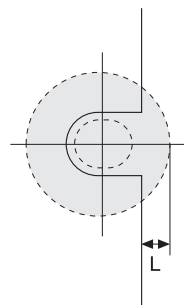
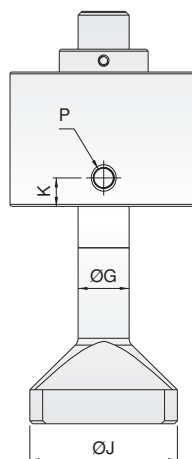
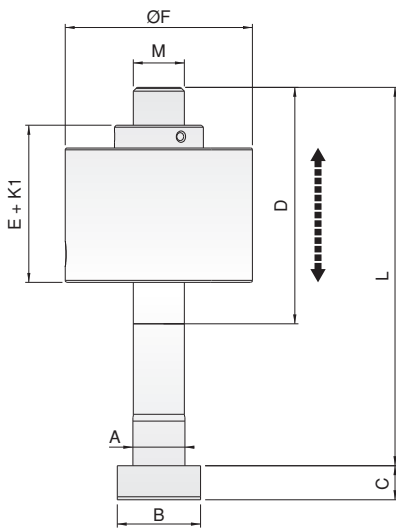

Hinweis
Der eingestellte Hub (Z) muss bei einer Änderung der Einstellungen kontrolliert werden.

Notes
The set stroke (Z) must be checked when changing the settings.

Modell / Model		CB-1	CB-2	CB-4	CB-6	CB-10	CB-16	CB-25
Spannkapazität Capacity of clamp	Ton	1	2	4	6	10	16	25
Total-Hub (X) Total stroke (X)	mm	6	8	8	8	8	8	8
Spannhub (Y) Stroke of clamp (Y)	mm	2.5	3	3	3	3	3	3
Schonhub (Z) Preserved stroke (Z)	mm	3.5	5	5	5	5	5	5
Zylinder-Gesamtvolumen Total volumn of cylinder	cc	3	7.5	13	21	38	55	98
Toleranzen Werkzeugunerteil-Dicke (H) The tolerance of the template thickness (H)	mm	±1.5	±2	±2	±2	±2	±2	±2



- Bei Bestellung bitte T-Nut-Größe (a,b,c,d) und Werkzeugunerteil-Dicke (H) angeben.
- Please indicate the size of T-slot (a,b,c,d) and the thickness (H) of the template for the die when purchasing.

Hydraulischer Druck / Hydraulic pressure : 250kg/cm²

Referenz-Nr. Order No.	L	K	J	H min.	H+d min. max	E min.	F	G	a min.	C min.	P
1015-CB01	74.5	60	14.5	25	100	42	44	20	10	6.5	PT1/8
1015-CB02	110	90	20	25	100	73	68	32	14	10	PT1/4
1015-CB04	134	110	24	25	130	77	79	40	18	12	PT1/4
1015-CB06	159	130	29	30	150	92	96	46	22	14	PT1/4
1015-CB10	189	159	30	40	140	114	117	54	24	16	PT1/4
1015-CB16	230	200	30	40	130	126	129	58	28	20	PT1/4
1015-CB25	265	235	30	45	120	148	156	70	36	23	PT1/4

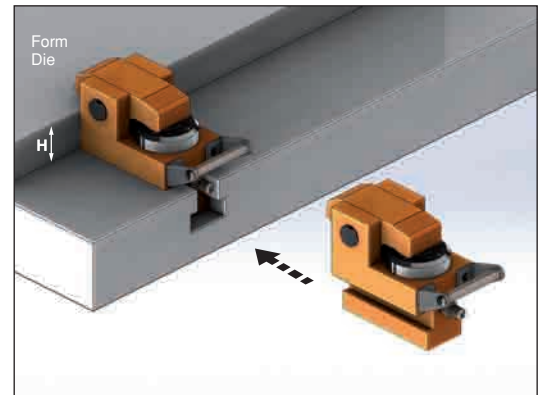

1015

- Spannmaße A, B C und D werden in T-Nut gespannt festgelegt.
- Temperatur Standard : 60°

1015

- The sizes of clamps(A),(B),(C) and (D) are made based on the size of T-slot.
- Standard Temperature : 60°

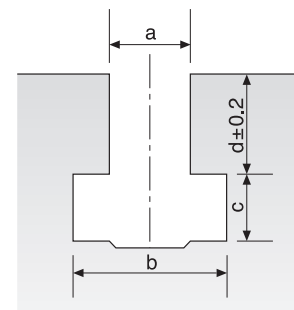
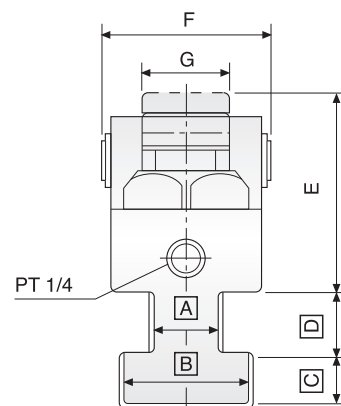
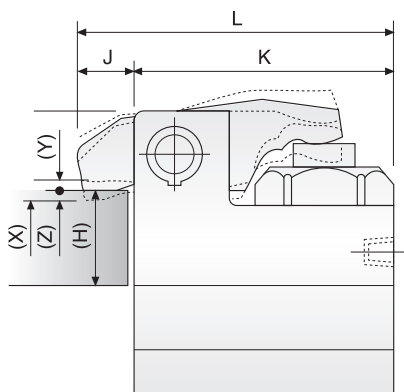

Modell / Model		CC-1	CC-2	CC-4	CC-6	CC-10
Spannkapazität Capacity of clamp	Ton	1	2	4	6	10
Total-Hub (X) Total stroke (X)	mm	9	9	9	12	12
Spannhub (Y) Stroke of clamp (Y)	mm	4	4	4	4	4
Schonhub (Z) Preserved stroke (Z)	mm	5	5	5	8	8
Zylinder-Gesamtvolumen Total volumn of cylinder	cc	3	7.5	13	21	38
Toleranzen Werkzeugunerteil-Dicke (H) The tolerance of the template thickness (H)	mm	±1.5	±2	±2	±2	±2



- Bei Bestellung bitte T-Nut-Größe (a,b,c,d) und Werkzeugunerteil-Dicke (H) angeben.
- Please indicate the size of T-slot (a,b,c,d) and the thickness (H) of the template for the die when purchasing.

Hydraulischer Druck / Hydraulic pressure : 250kg/cm²

Referenz-Nr. Order No.	H min. - max	A min.	C min.	E	F	G	I	J	K	L min.	M	T	U
1015-CC01	20-35	10	6.5	43	G+43	H+9	Ø16	75	33	27	21.5	1/8	M5
1015-CC02	25-40	14	10	50	G+50	H+9	Ø18	91	43	30	25	1/8	M5
1015-CC04	25-40	18	12	65	G+60	H+9	Ø30	115	55	40	32.5	1/8	M8
1015-CC06	35-55	22	14	80	G+65	H+12	Ø37.5	130	65	48	40	1/4	M10
1015-CC10	40-60	24	16	100	G+82	H+12	Ø50	160	85	60	49	1/4	M12

1015

- Spannmaße A, B C und D werden in T-Nut gespannt festgelegt.
- Temperatur Standard : 60°

1015

- The sizes of clamps(A),(B),(C) and (D) are made based on the size of T-slot.
- Standard Temperature : 60°

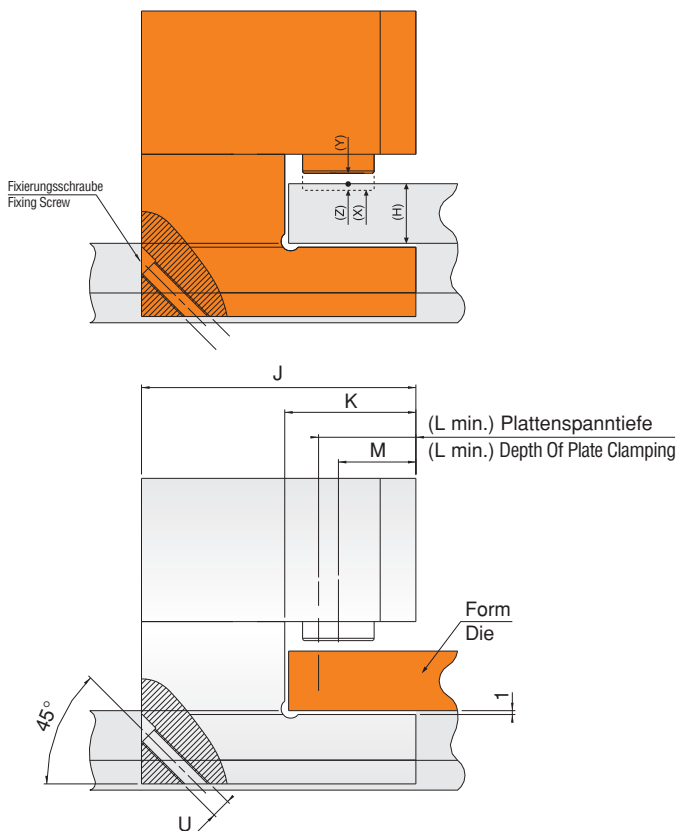
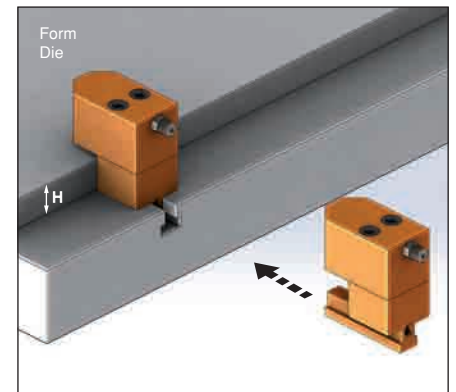



Modell / Model		CD-2	CD-4	CD-6	CD-10	CD-16	CD-25
Spannkapazität Capacity of clamp	Ton	2	4	6	10	16	25
Total-Hub (X) Total stroke (X)	mm	8	8	8	8	8	8
Spannhub (Y) Stroke of clamp (Y)	mm	3	3	3	3	3	3
Schonhub (Z) Preserved stroke (Z)	mm	5	5	5	5	5	5
Zylinder-Gesamtvolumen Total volumn of cylinder	cc	7.5	13	21	38	55	98
Toleranzen Werkzeugunerteil-Dicke (H) The tolerance of the template thickness (H)	mm	±2	±2	±2	±2	±2	±2

Hydraulischer Druck / Hydraulic pressure : 250kg/cm²

Referenz-Nr. Order No.	A	B	C	D	E min.	F	G	W	N max.	T
1015-CD02	12	20	80	98	90	76	30	124	25	M10x20D
1015-CD04	12	25	100	109	93	87	30	135	30	M12x24D
1015-CD06	15	30	120	126	109	104	30	152	35	M12x24D
1015-CD10	15	35	150	148	131	124	36	174	40	M14x28D
1015-CD16	20	40	200	166	142	138	44	200	50	M18x36D
1015-CD25	20	45	235	200	163	168	48	240	60	M22x45D

1015

- Temperatur Standard : 60°

1015

- Standard Temperature : 60°

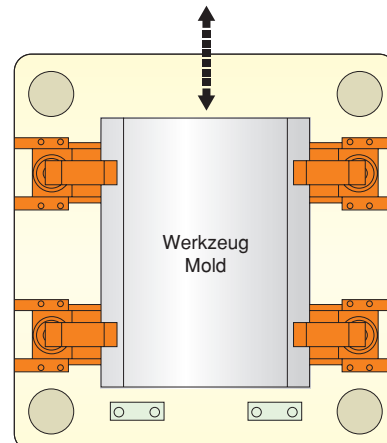
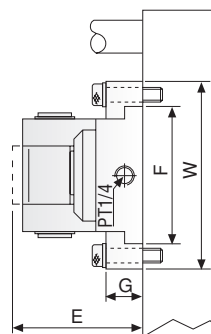
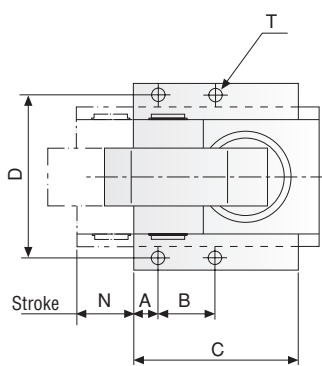

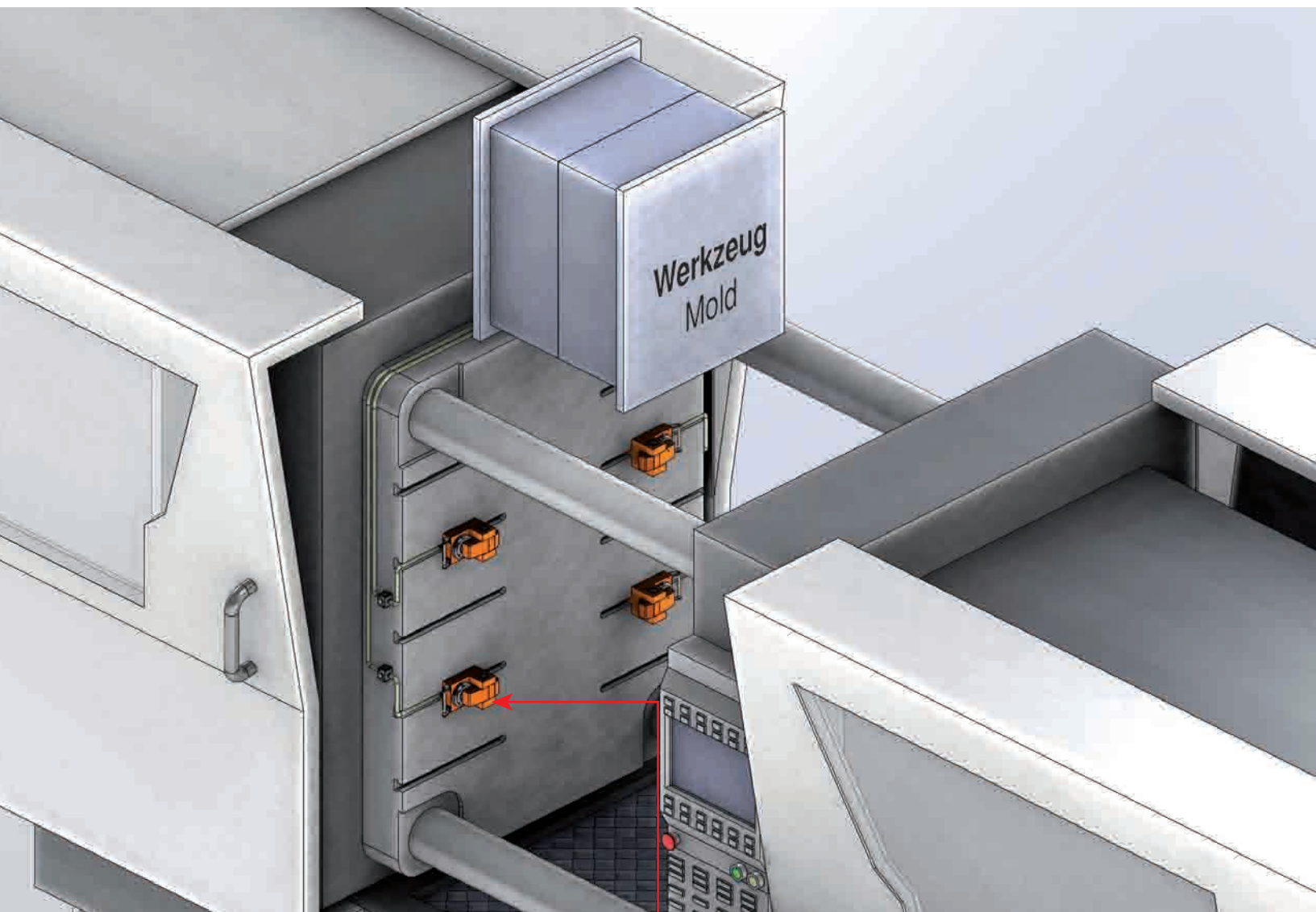

Hydraulische Spannelemente / Hydraulic Clamp Models



Model CA



Model CV



Model CB



Model CC



Model CD

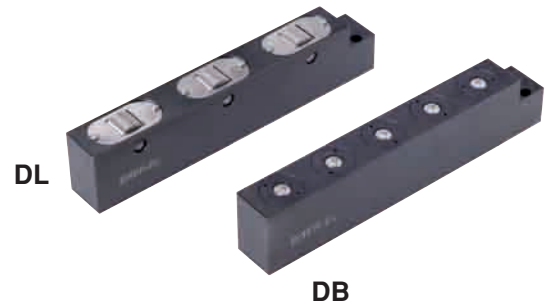
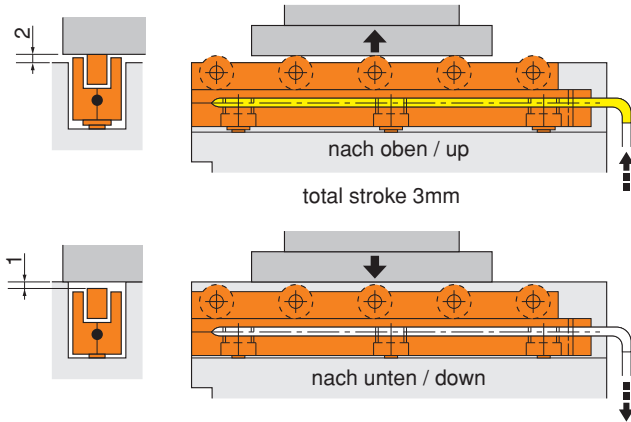

Außenmaße Outline Dimensions	<p>D□18 Serie / Series</p>
Plattenbearbeitungsmaß (U-Nut) Processing Size for Plate (U-slot)	

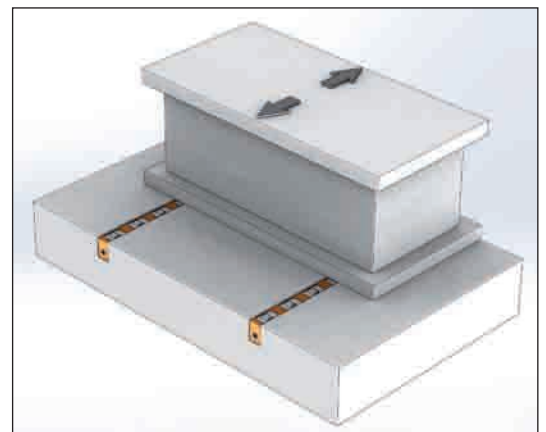

**Model DL Bewegungsrichtung
Model DL Movement Direction**

Referenz-Nr. Order No.	L	D□18				Hydr. Zylinder Hyd. cylinder	
		DL18		DB18		Menge Quantity	Kapazität Capacity kg
		Ring Roller (DL)	Kapazität Capacity kg	Kugel Ball (DB)	Kapazität Capacity kg		
1020-0200	200	3	300	5	250	2	560
1020-0300	300	5	500	7	350		
1020-0400	400	6	560	10	500	3	840
1020-0500	500	8	800	12	600		
1020-0600	600	9	840	15	750		
1020-0700	700	11	840	17	840	4	1120
1020-0800	800	12	1120	20	1000		
1020-0900	900	14	1120	22	1100	5	1400
1020-1000	1000	15	1250	25	1250		

1020
• Temperatur Standard : 60°

1020
• Standard Temperature : 60°

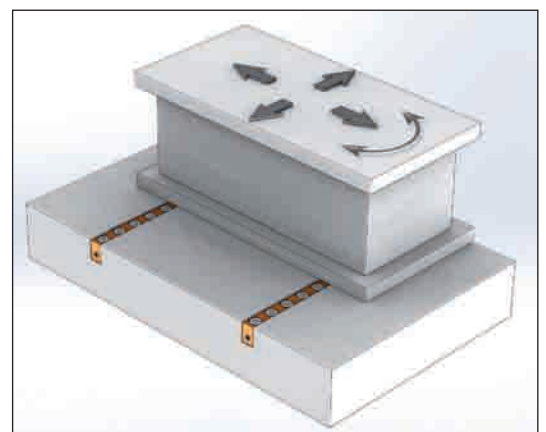

**Model DB Bewegungsrichtung
Model DB Movement Direction**

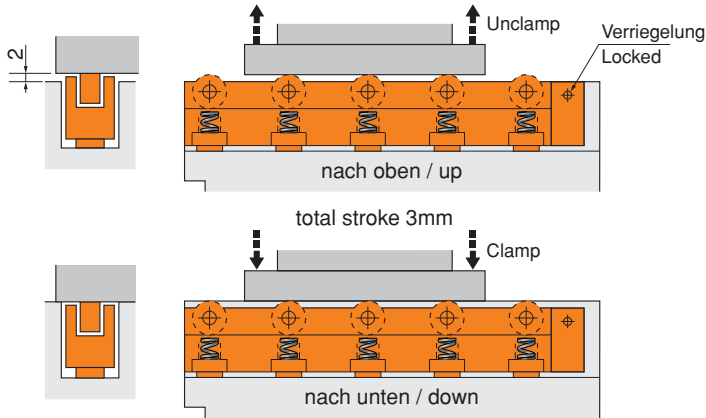

Außenmaße Outline Dimensions	<p>D□18 Serie / Series</p>
Plattenbearbeitungsmaß (U-Nut) Processing Size for Plate (U-slot)	

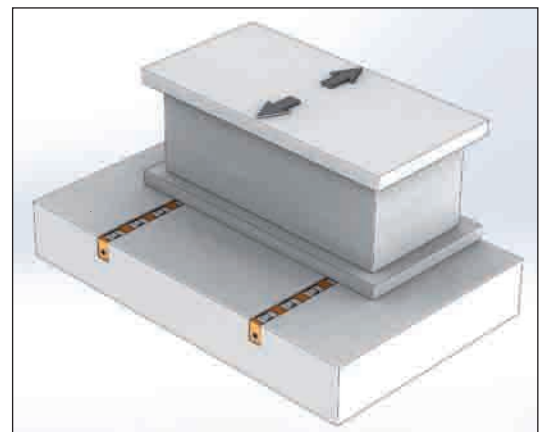

Model DLS Bewegungsrichtung
Model DLS Movement Direction

Referenz-Nr. Order No.	L	D□18					
		DLS18			DBS18		
		Ring Roller (DLS)		Kapazität Capacity kg	Kugel Ball (DBS)		Kapazität Capacity kg
1022-0200	200	3	4	200	5	6	150
1022-0300	300	5	6	300	7	8	200
1022-0400	400	6	7	350	10	11	275
1022-0500	500	8	9	450	12	13	325
1022-0600	600	9	10	500	15	16	400
1022-0700	700	11	12	600	17	18	450
1022-0800	800	12	13	650	20	21	525
1022-0900	900	14	15	750	22	23	575
1022-1000	1000	15	16	800	25	26	650

1022
• Temperatur Standard : 60°

1022
• Standard Temperature : 60°

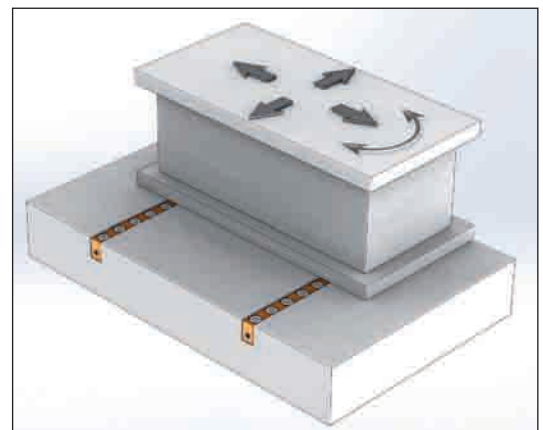

Model DBS Bewegungsrichtung
Model DBS Movement Direction

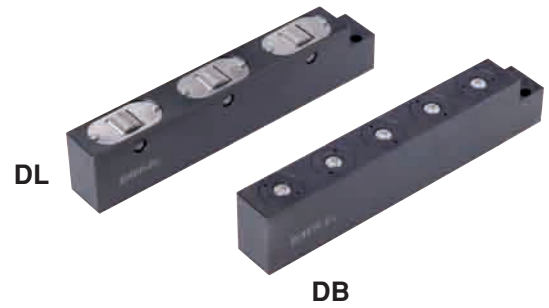
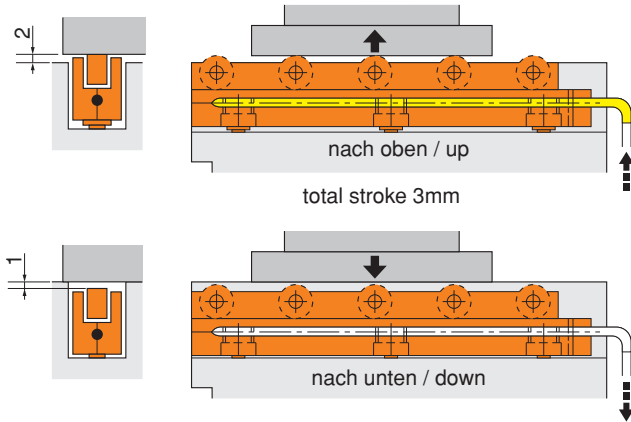

Außenmaße Outline Dimensions	<p>D□22 Serisi / Serial</p>
Plattenbearbeitungsmaß (U-Nut) Processing Size for Plate (U-slot)	

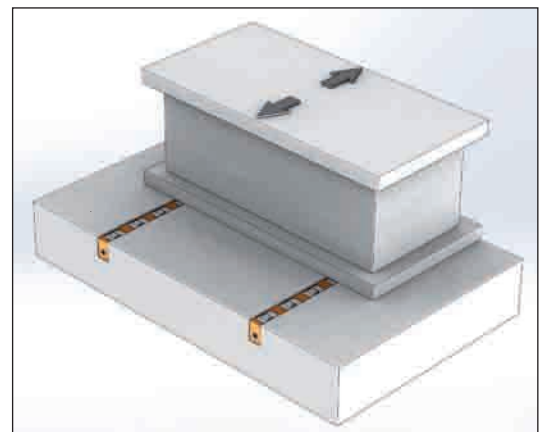

**Model DL Bewegungsrichtung
Model DL Movement Direction**

Referenz-Nr. Order No.	L	D□22				Hid. Silindir Hyd. cylinder	
		DL22		DB22		Menge Quantity	Kapazität Capacity kg
		Ring Roller (DL)	Kapazität Capacity kg	Kugel Ball (DB)	Kapazität Capacity kg		
1020-0200	200	3	480	5	370	2	1000
1020-0300	300	5	800	7	518		
1020-0400	400	6	960	10	740		
1020-0500	500	8	1280	12	888	3	1500
1020-0600	600	9	1400	15	1110		
1020-0700	700	11	1500	17	1250		
1020-0800	800	12	1920	20	1480		
1020-0900	900	14	2000	22	1628	4	2000
1020-1000	1000	15	2000	25	1850		

1020
• Temperatur Standard : 60°

1020
• Standard Temperature : 60°

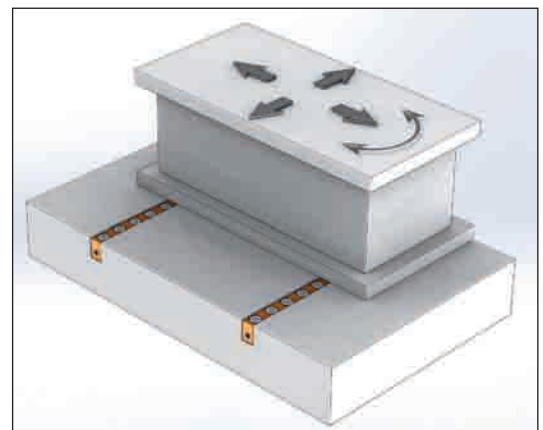

**Model DB Bewegungsrichtung
Model DB Movement Direction**

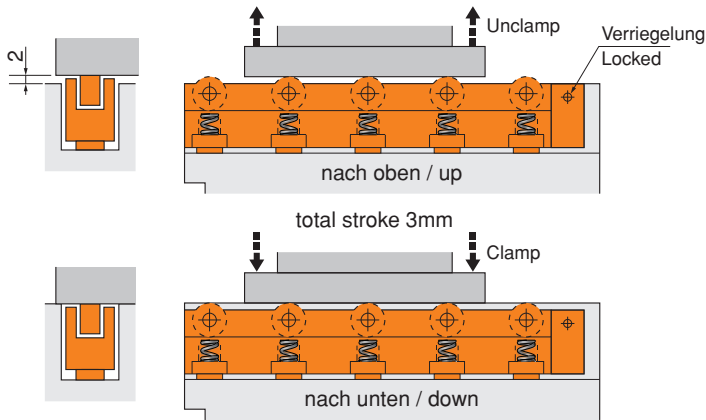

Außenmaße Outline Dimensions	<p>D□22 Serisi / Serial</p>
Plattenbearbeitungsmaß (U-Nut) Processing Size for Plate (U-slot)	

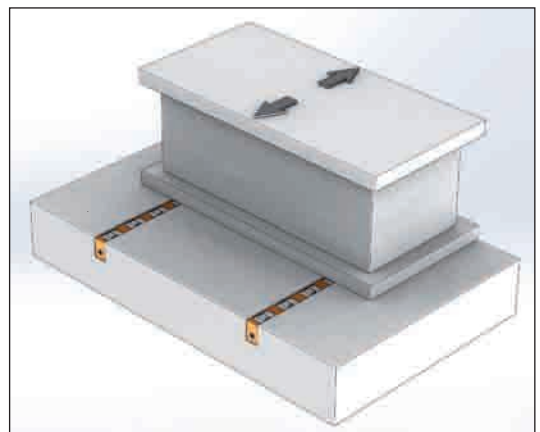

**Model DLS Bewegungsrichtung
Model DLS Movement Direction**

Referenz-Nr. Order No.	L	D□22					
		DLS22			DBS22		
		Ring Roller (DLS)		Kapazität Capacity kg	Kugel Ball (DBS)		Kapazität Capacity kg
1022-0200	200	3	3	240	5	5	200
1022-0300	300	5	5	400	7	7	280
1022-0400	400	6	6	480	10	10	400
1022-0500	500	8	8	640	12	12	480
1022-0600	600	9	9	720	15	15	600
1022-0700	700	11	11	880	17	17	680
1022-0800	800	12	12	960	20	20	800
1022-0900	900	14	14	1120	22	22	880
1022-1000	1000	15	15	1200	25	25	1000

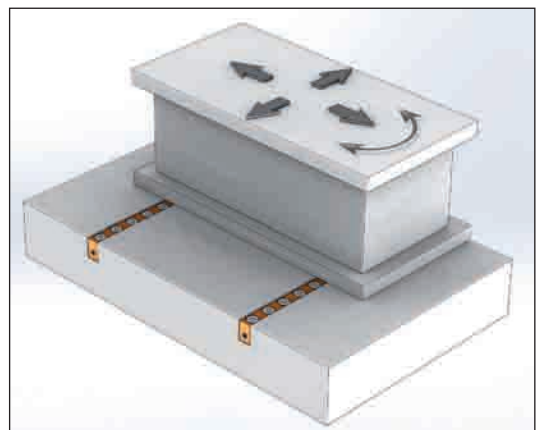

**Model DBS Bewegungsrichtung
Model DBS Movement Direction**

1022
• Temperatur Standard : 60°

1022
• Standard Temperature : 60°

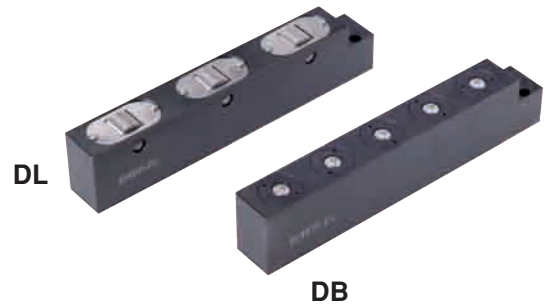
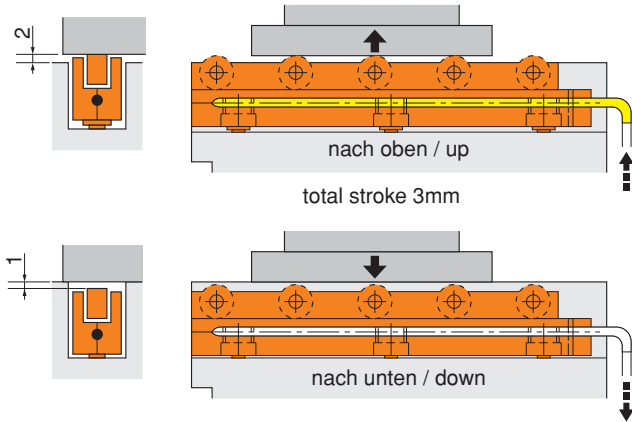

Außenmaße Outline Dimensions	<p>D□28 Serie / Series</p>
	<p>Plattenbearbeitungsmaß (U-Nut) Processing Size for Plate (U-slot)</p>

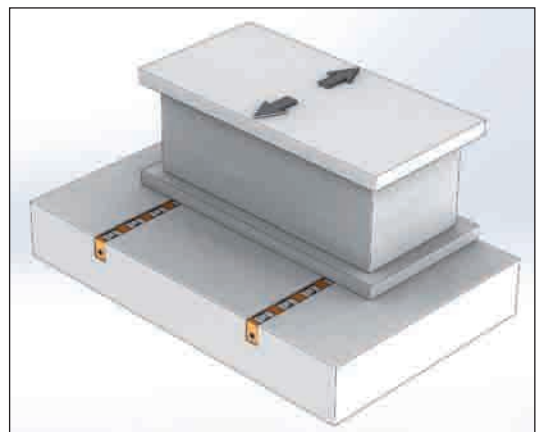

Model DL Bewegungsrichtung
Model DL Movement Direction

Referenz-Nr. Order No.	L	D□28					
		DL28		DB28		Hydr. Zylinder Hyd. cylinder	
		Ring Roller (DL)	Kapazität Capacity kg	Kugel Ball (DB)	Kapazität Capacity kg	Menge Quantity	Kapazität Capacity kg
1020-0200	200	3	750	5	475		
1020-0300	300	5	1250	7	665	2	1260
1020-0400	400	6	1260	10	950		
1020-0500	500	8	1890	12	1140		
1020-0600	600	9	1890	15	1425	3	1890
1020-0700	700	11	1890	17	1615		
1020-0800	800	12	2520	20	1900	4	2520
1020-0900	900	14	2520	22	2090		
1020-1000	1000	15	3150	25	2375		
1020-1100	1100	16	3150	27	2565	5	3150
1020-1200	1200	17	3150	30	2850		
1020-1300	1300	18	3780	32	3040		
1020-1400	1400	19	3780	35	3325	6	3780
1020-1500	1500	20	3780	37	3515		
1020-1600	1600	22	4410	40	3800		
1020-1700	1700	24	4410	42	3990	7	4410
1020-1800	1800	25	4410	45	4275		
1020-1900	1900	27	5040	47	4465	8	5040

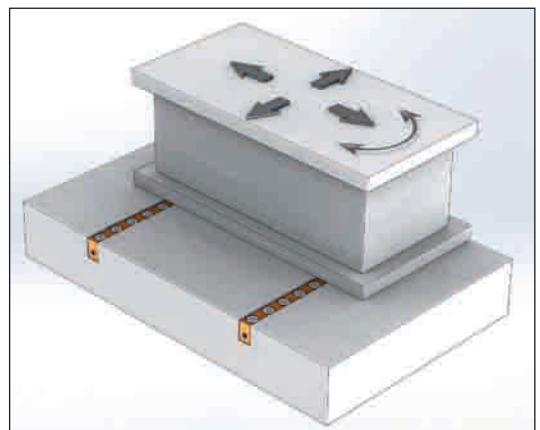

Model DB Bewegungsrichtung
Model DB Movement Direction

1020
• Temperatur Standard : 60°

1020
• Standard Temperature : 60°

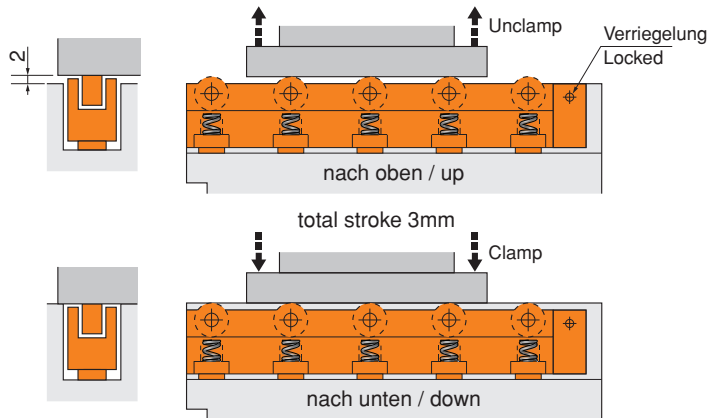

Außenmaße Outline Dimensions	<p>D□28 Serie / Series</p>
Plattenbearbeitungsmaß (U-Nut) Processing Size for Plate (U-slot)	

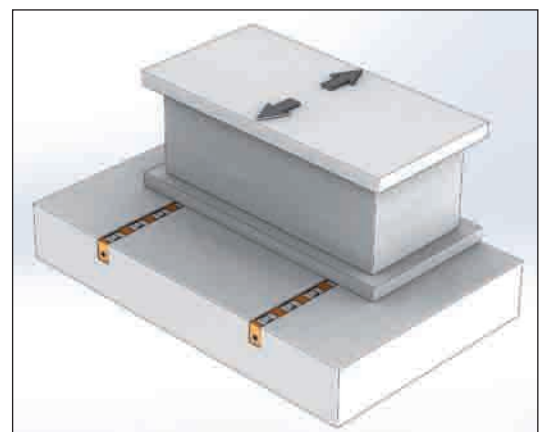

Model DLS Bewegungsrichtung
Model DLS Movement Direction

Referenz-Nr. Order No.	L	D□28					
		DLS28			DBS28		
		Ring Roller (DLS)		Kapazität Capacity kg	Kugel Ball (DBS)		Kapazität Capacity kg
1022-0200	200	3	4	500	5	5	315
1022-0300	300	5	6	750	7	7	441
1022-0400	400	6	7	875	10	10	630
1022-0500	500	8	9	1125	12	12	756
1022-0600	600	9	10	1250	15	15	945
1022-0700	700	11	12	1500	17	17	1071
1022-0800	800	12	13	1625	20	20	1260
1022-0900	900	14	15	1875	22	22	1386
1022-1000	1000	15	16	2000	25	25	1575
1022-1100	1100	16	17	2125	27	27	1701
1022-1200	1200	17	18	2250	30	30	1890
1022-1300	1300	18	19	2375	32	32	2016
1022-1400	1400	19	20	2500	35	35	2205
1022-1500	1500	20	21	2625	37	37	2331
1022-1600	1600	22	23	2875	40	40	2520
1022-1700	1700	24	25	3125	42	42	2646
1022-1800	1800	25	26	3250	45	45	2835
1022-1900	1900	27	28	3500	47	47	2961

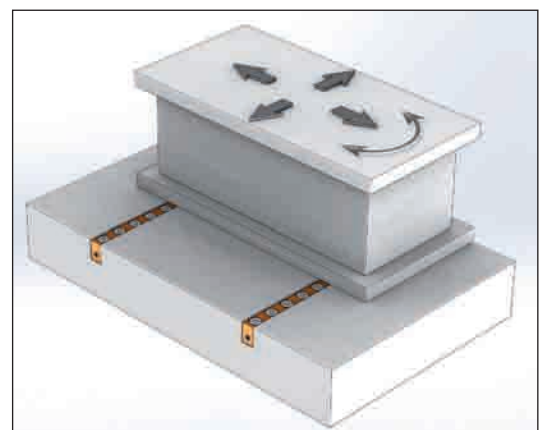

Model DBS Bewegungsrichtung
Model DBS Movement Direction

1022
• Temperatur Standard : 60°

1022
• Standard Temperature : 60°

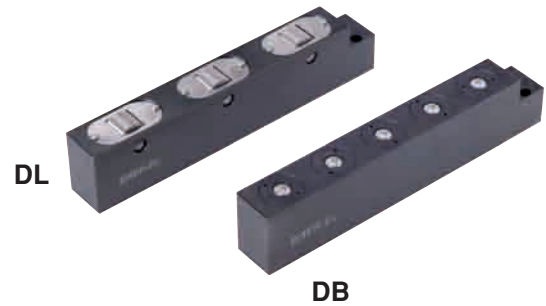
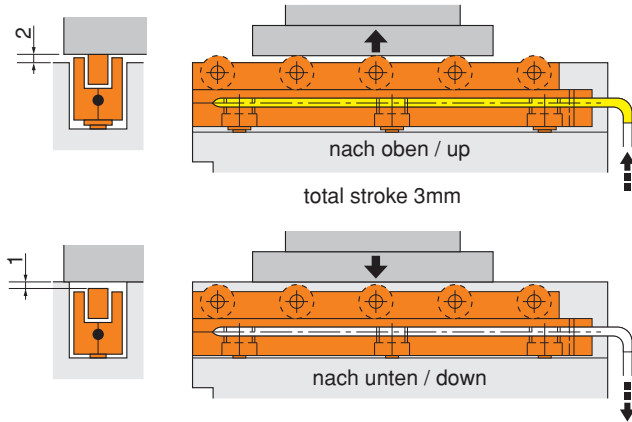

Außenmaße Outline Dimensions	<p>□36 Serie / Series</p>
	<p>Plattenbearbeitungsmaß (U-Nut) Processing Size for Plate (U-slot)</p>

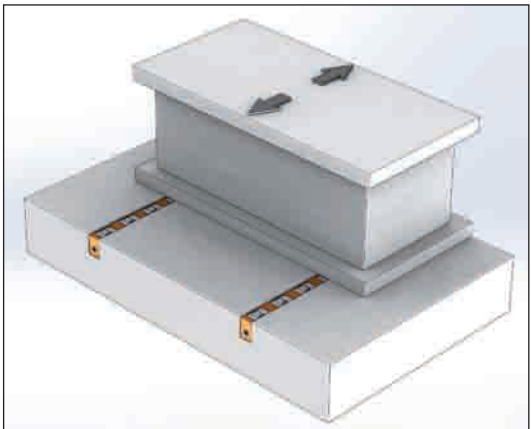

Model DL Bewegungsrichtung
Model DL Movement Direction

Referenz-Nr. Order No.	L	□36					
		DL36		DB36		Hydr. Zylinder Hyd. cylinder	
		Ring Roller (DL)	Kapazität Capacity kg	Kugel Ball (DB)	Kapazität Capacity kg	Menge Quantity	Kapazität Capacity kg
1020-0200	200	3	1050	5	600	2	1700
1020-0300	300	5	1750	7	840		
1020-0400	400	6	1700	10	1200	3	2600
1020-0500	500	8	2600	12	1440		
1020-0600	600	9	2600	15	1800		
1020-0700	700	11	2600	17	2040		
1020-0800	800	12	2600	20	2400	4	3500
1020-0900	900	14	3500	22	2640		
1020-1000	1000	15	3500	25	3000		
1020-1100	1100	16	3500	27	3240	5	4400
1020-1200	1200	17	4400	30	3600		
1020-1300	1300	18	4400	32	3840		
1020-1400	1400	19	4400	35	4200	6	5300
1020-1500	1500	20	4400	37	4400		
1020-1600	1600	22	5300	40	4800		
1020-1700	1700	24	5300	42	5040	6	5300
1020-1800	1800	25	5300	45	5300		
1020-1900	1900	27	5300	47	5300		

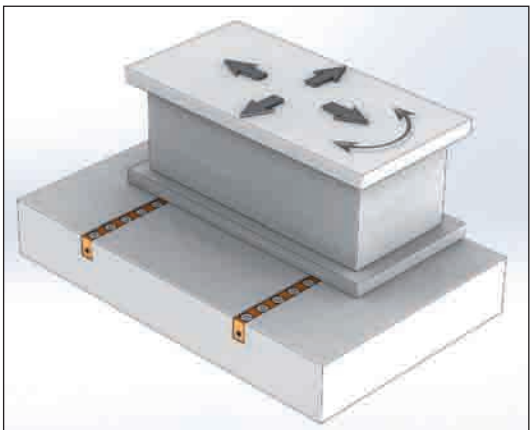

Model DB Bewegungsrichtung
Model DB Movement Direction

1020
• Temperatur Standard : 60°

1020
• Standard Temperature : 60°

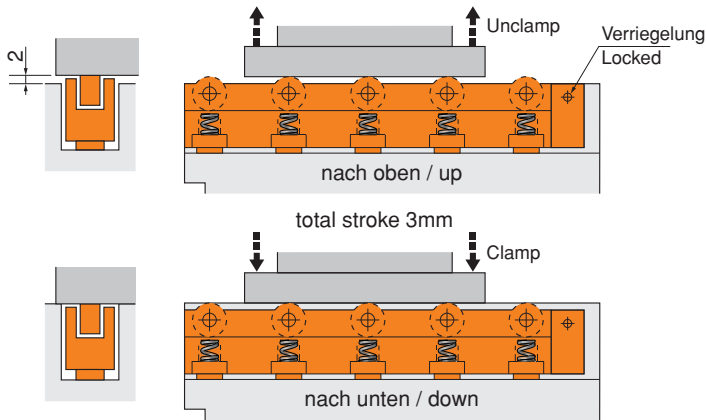

Außenmaße Outline Dimensions	<p>D□36 Serie / Series</p>
Plattenbearbeitungsmaß (U-Nut) Processing Size for Plate (U-slot)	

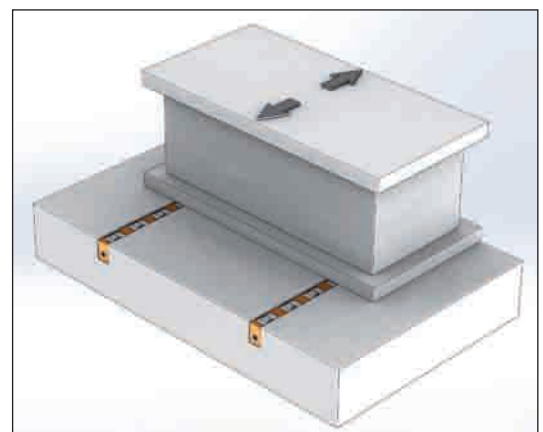

Model DLS Bewegungsrichtung
Model DLS Movement Direction

Referenz-Nr. Order No.	L	D□36					
		DLS36			DBS36		
		Ring Roller (DLS)		Kapazität Capacity kg	Kugel Ball (DBS)		Kapazität Capacity kg
1022-0200	200	3	3	600	5	5	500
1022-0300	300	5	5	1000	7	7	700
1022-0400	400	6	6	1200	10	10	1000
1022-0500	500	8	8	1600	12	12	1200
1022-0600	600	9	9	1800	15	15	1500
1022-0700	700	11	11	2200	17	17	1700
1022-0800	800	12	12	2400	20	20	2000
1022-0900	900	14	14	2800	22	22	2200
1022-1000	1000	15	15	3000	25	25	2500
1022-1100	1100	16	16	3200	27	27	2700
1022-1200	1200	17	17	3400	30	30	3000
1022-1300	1300	18	18	3600	32	32	3200
1022-1400	1400	19	19	3800	35	35	3500
1022-1500	1500	20	20	4000	37	37	3700
1022-1600	1600	22	22	4400	40	40	4000
1022-1700	1700	24	24	4800	42	42	4200
1022-1800	1800	25	25	5000	45	45	4500
1022-1900	1900	27	27	5400	47	47	4700

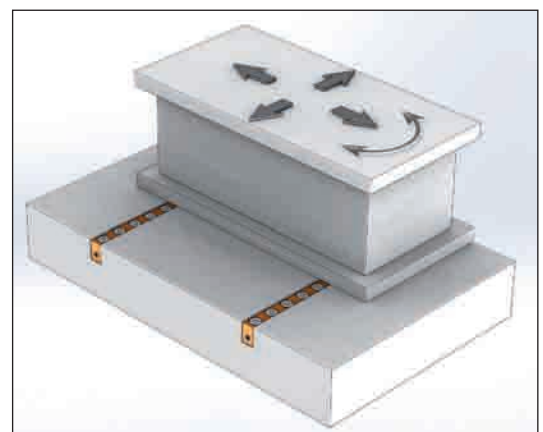

Model DBS Bewegungsrichtung
Model DBS Movement Direction

1022
• Temperatur Standard : 60°

1022
• Standard Temperature : 60°

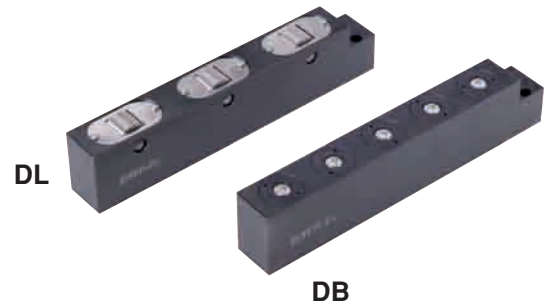
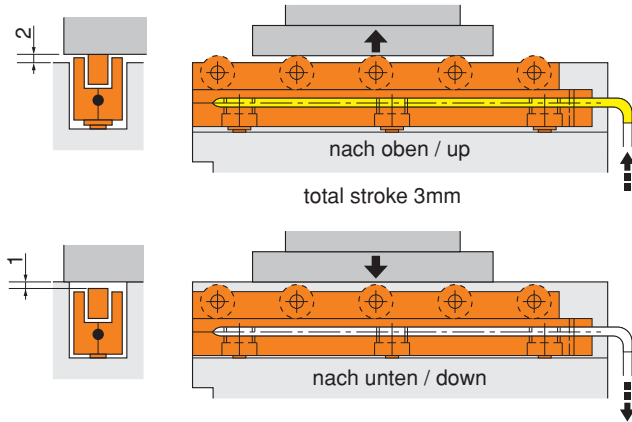

	D□50 Serie / Series	D□50 Serie / Series
Außenmaße Outline Dimensions		
Plattenbearbeitungsmaß (U-Nut) Processing Size for Plate (U-slot)		

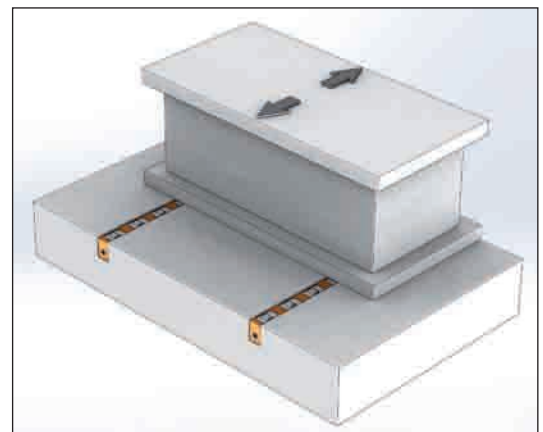

Model DL Bewegungsrichtung
Model DL Movement Direction

Referenz-Nr. Order No.	L	D□50					
		DL50		DB50		Hid. Silindir Hyd. cylinder	
		Ring Roller (DL)	Kapazität Capacity kg	Kugel Ball (DB)	Kapazität Capacity kg	Menge Quantity	Kapazität Capacity kg
1020-0200	200	2	1000	4	640	2	2200
1020-0300	300	3	1500	6	960		
1020-0400	400	4	2000	9	1440	3	3300
1020-0500	500	5	2500	11	1760		
1020-0600	600	6	3000	13	2080		
1020-0700	700	7	3300	16	2560	4	4400
1020-0800	800	8	3300	18	2880		
1020-0900	900	9	4400	20	3200	5	5500
1020-1000	1000	10	4400	23	3680		
1020-1100	1100	11	4400	25	4000		
1020-1200	1200	12	5500	27	4320	6	6600
1020-1300	1300	13	5500	29	4640		
1020-1400	1400	14	5500	31	4960	7	7700
1020-1500	1500	15	5500	33	5280		
1020-1600	1600	16	6500	35	5600		
1020-1700	1700	17	6500	38	6080	8	8800
1020-1800	1800	18	6500	40	6400		
1020-1900	1900	19	6500	42	6720	8	8800
1020-2000	2000	20	7700	44	7040		
1020-2100	2100	21	7700	46	7360		
1020-2200	2200	22	7700	48	7680	8	8800
1020-2300	2300	23	7700	50	7700		
1020-2400	2400	24	8800	52	8320	8	8800
1020-2500	2500	25	8800	54	8640		

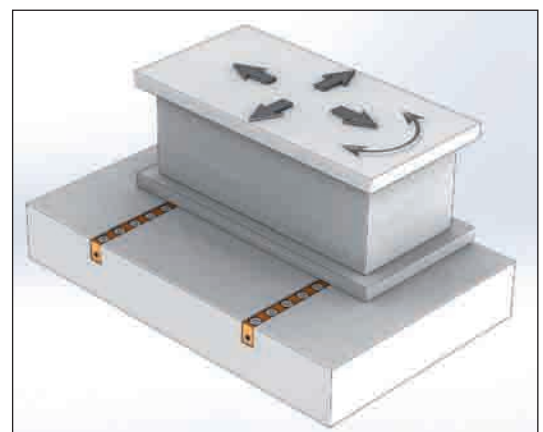

Model DB Bewegungsrichtung
Model DB Movement Direction

1020
• Temperatur Standard : 60°

1020
• Standard Temperature : 60°

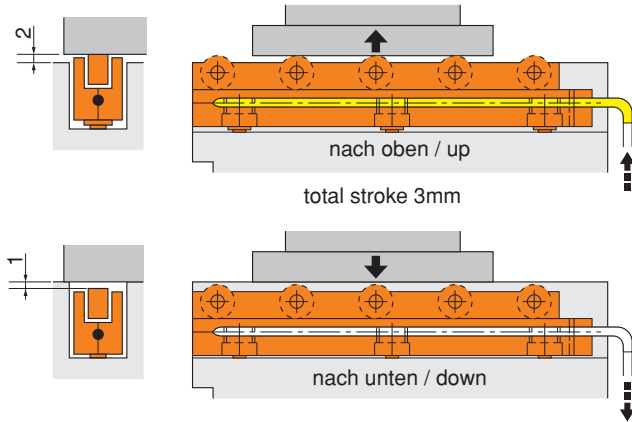

Außenmaße Outline Dimensions	D□80 Serie / Series
Plattenbearbeitungsmaß (U-Nut) Processing Size for Plate (U-slot)	

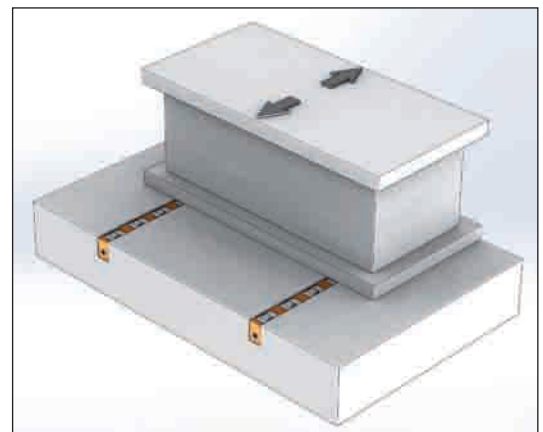

Model DL Bewegungsrichtung
Model DL Movement Direction

Referenz-Nr. Order No.	L	D□80			
		DL80		Hid. Silindir Hyd. cylinder	
		Ring Roller (DL)	Kapazität Capacity kg	Menge Quantity	Kapazität Capacity kg
1020-0200	200	-	-	-	-
1020-0300	300	-	-	-	-
1020-0400	400	-	-	-	-
1020-0500	500	5	3250	2	5600
1020-0600	600	6	3900		
1020-0700	700	7	4550	3	8400
1020-0800	800	8	5200		
1020-0900	900	9	5850		
1020-1000	1000	10	6500	4	11200
1020-1100	1100	11	7150		
1020-1200	1200	12	7800		
1020-1300	1300	13	8450		
1020-1400	1400	14	9100	5	14000
1020-1500	1500	15	9750		
1020-1600	1600	16	10400		
1020-1700	1700	17	11050	6	16800
1020-1800	1800	18	11700		
1020-1900	1900	19	12350		
1020-2000	2000	20	13000		
1020-2100	2100	21	13650	7	19600
1020-2200	2200	22	14300		
1020-2300	2300	23	14950		
1020-2400	2400	24	15600		
1020-2500	2500	25	16250		

1020
• Temperatur Standard : 60°

1020
• Standard Temperature : 60°

Modell / Model RC - RD - RE/RF - RS

Modellauswahl / Model Selection

R ① - ②

Modell Model	Lagermethode Storage Method	Beschreibung Specification
C	demontiert / dismantling	580 mm
D	hängend / hanging	760 mm
E	klappend (kurz) / folding (short)	880 mm
F	klappend (lang) / folding (long)	990 mm

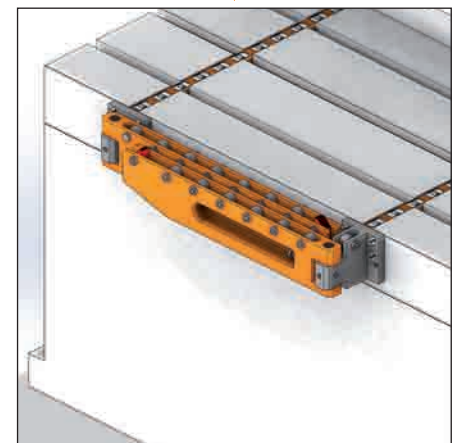
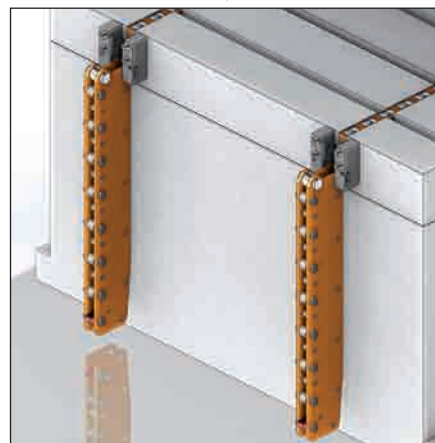
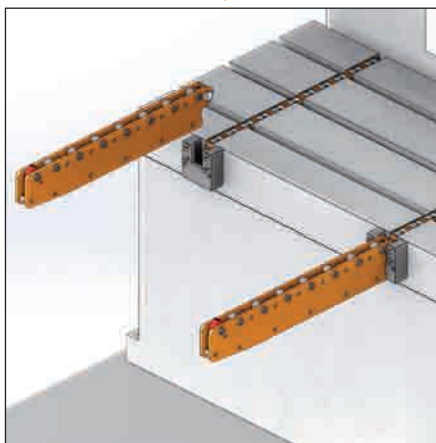
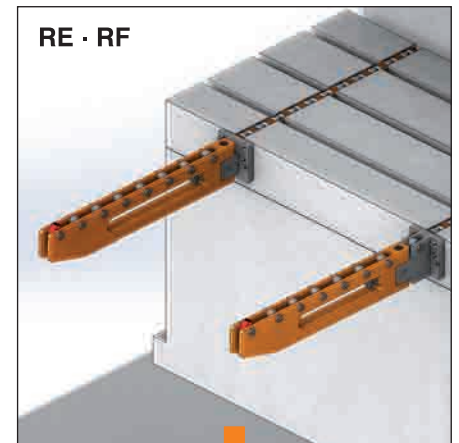
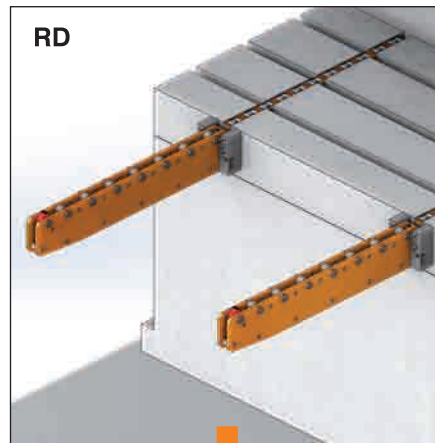
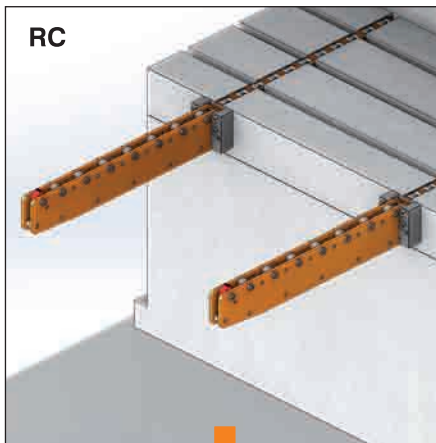
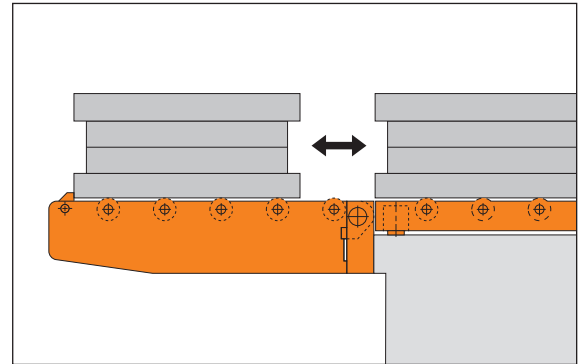

Referenz-Nr. Order No.	Modell Stütze Model of Support	erforderliche Werkzeuiglänge Length Needed of the Die L (mm)	Max. Kapazität Max. Capacity (kgf)	Gesamtlänge Total Length A (mm)	Maße Stütze Size of Support			Lochform für Montage Hole Pattern For Installation	Anzahl Zylinder Number of Roller
					D	B	H		
1025-RC580	RC-12	500	800	550	48	115	118	A Type	5
1025-RC760	RC-12	700	600	750	48	115	118	A Type	7
1025-RC880	RC-16	800	800	850	48	115	158	B Type	8
1025-RC990	RC-20	900	900	950	48	115	188	B Type	9
1027-RC05125	RC-14H	500	1250	550	55	130	138	C Type	7
1027-RC05160	RC-16H	500	1600	550	55	130	158	C Type	7
1027-RC05200	RC-18H	500	2000	550	55	130	178	C Type	7
1027-RC07125	RC-14H	700	1250	750	55	130	138	C Type	9
1027-RC07160	RC-16H	700	1600	750	55	130	158	C Type	9
1027-RC07200	RC-18H	700	2000	750	55	130	178	C Type	9
1027-RC08125	RC-16H	800	1250	850	55	130	158	C Type	10
1027-RC08160	RC-18H	800	1600	850	55	130	178	C Type	10
1027-RC08200	RC-20H	800	2000	850	55	130	188	C Type	10
1027-RC09160	RC-22H	900	1600	950	55	130	218	C Type	11

1027

Modell / Model RC (Demontage / Dismantling)

- Arm und Stütze können separat verwendet werden
- The arm itself and the support in Model RC can be used separately.

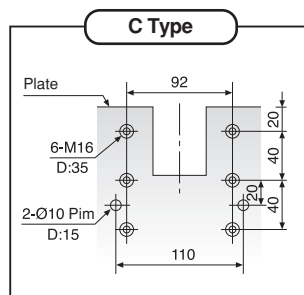
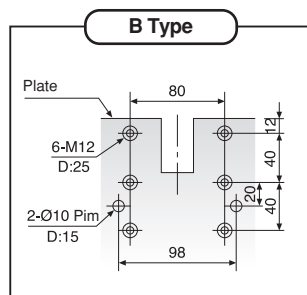
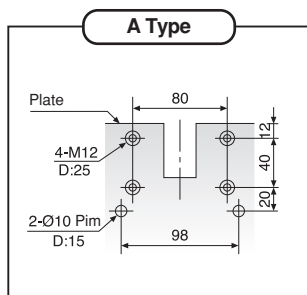
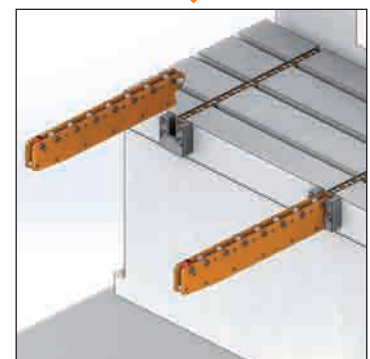
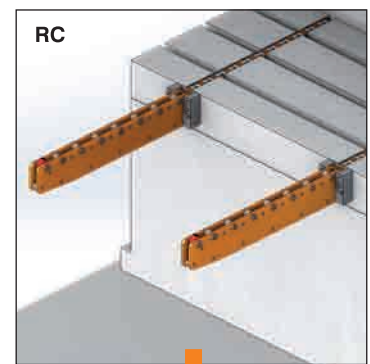
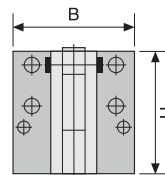
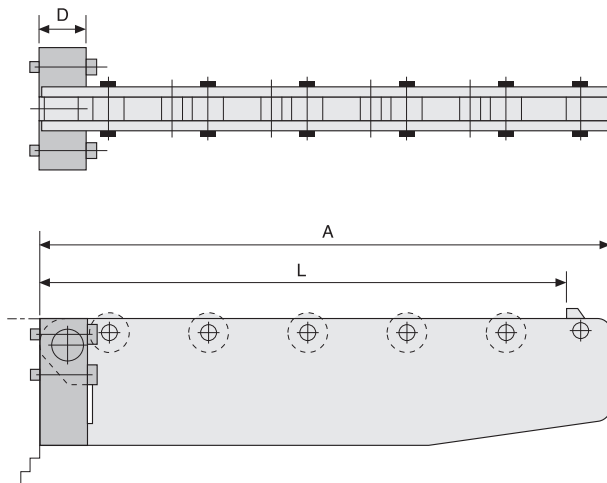
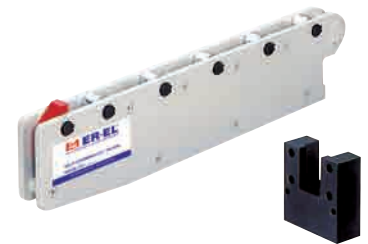

Referenz-Nr. Order No.	erforderliche Werkzeuglänge Length Needed of the Die L (mm)	Max. Kapazität Max. Capacity (kgf)	Gesamtlänge Total Length A (mm)	Hängemaße Size of Hanging		Maße Stütze Size of Support			Lochform für Montage Hole Pattern For Installation	Anzahl Zylinder Number of Roller
				X	Y	D	B	H		
1030-RD580	500	800	550	140	620	52	115	118	A Type	5
1030-RD760	700	600	750	140	820	52	115	118	A Type	7
1030-RD880	800	800	850	180	960	52	115	158	B Type	8
1030-RD990	900	900	950	220	1100	52	115	188	B Type	9
1030-RD05125	500	1250	550	170	645	62	130	138	C Type	7
1030-RD05160	500	1600	550	190	670	62	130	158	C Type	7
1030-RD05200	500	2000	550	210	675	62	130	178	C Type	7
1030-RD07125	700	1250	750	170	840	62	130	138	C Type	9
1030-RD07160	700	1600	750	190	865	62	130	158	C Type	9
1030-RD07200	700	2000	750	210	890	62	130	178	C Type	9
1030-RD08125	800	1250	850	190	960	62	130	158	C Type	10
1030-RD08160	800	1600	850	210	985	62	130	178	C Type	10
1030-RD08200	800	2000	850	220	995	62	130	188	C Type	10
1030-RD09160	900	1600	950	250	1130	62	130	218	C Type	11

1030
Modell / Model RD (Hängend / Hanging)

- Hängelänge (Y) muss niedriger als das Maß zwischen Boden und Platte sein.
- The hanging length (Y) of Model RD should be less than the height between the plate and the ground

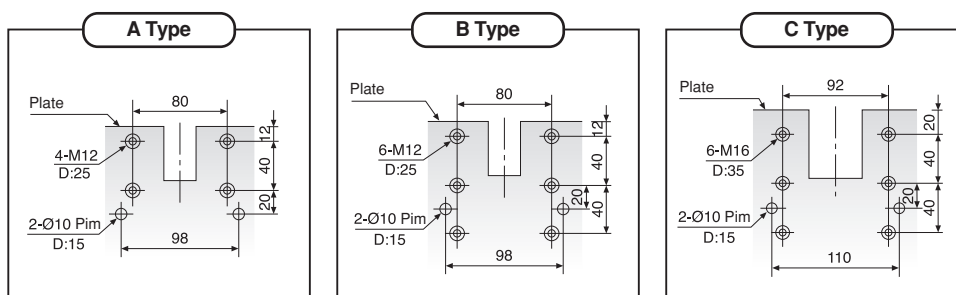
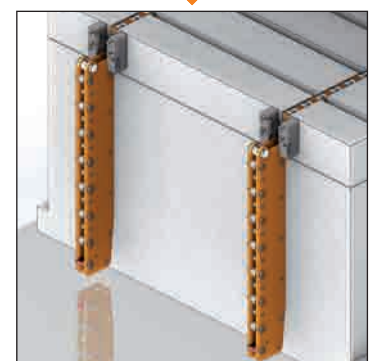
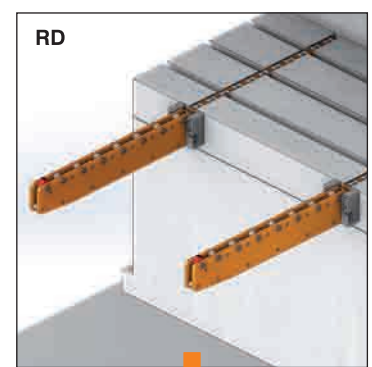
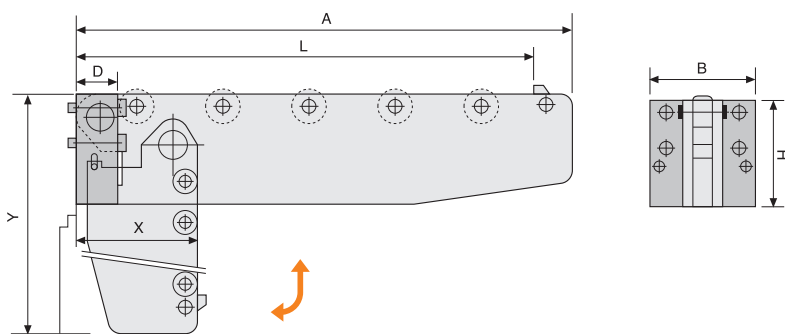

Referenz-Nr. Order No.	erforderliche Werkzeuflänge Length Needed of the Die L (mm)	Max. Kapazität Max. Capacity (kgf)	Gesamtlänge Total Length A (mm)	erforderliche min. Distanz für Montage Min. Distance for Installation C (mm)	Dimensionen (zugeklappt) dimensions (folded)		Maße Stütze Size of Support		Anzahl Zylinder Number of Roller	M	N	Lochform für Montage Hole Pattern For Installation
					X	Y	B	H				
1033-RERF580	500	800	550	525	90	150	115	118	5	57	120	A Type
1033-RERF760	700	600	750	725	90	150	115	118	7	57	120	A Type
1033-RERF880	800	800	850	825	90	150	115	158	8	57	120	B Type
1033-RERF990	900	900	950	925	90	150	115	188	9	57	120	B Type

1033

- Klappbar nach rechts oder links

1033

- Itself can be turned left or right for storage.

Referenz-Nr. Order No.	erforderliche Werkzeuflänge Length Needed of the Die L (mm)	Max. Kapazität Max. Capacity (kgf)	Gesamtlänge Total Length A (mm)	erforderliche min. Distanz für Montage Min. Distance for Installation C (mm)	Dimensionen (zugeklappt) dimensions (folded)		Maße Stütze Size of Support		Anzahl Zylinder Number of Roller	M	N	Lochform für Montage Hole Pattern For Installation
					X	Y	B	H				
1035-RERF05160	500	1600	550	525	105	170	130	158	7	74	140	C Type
1035-RERF05200	500	2000	550	525	105	170	130	178	7	74	140	C Type
1035-RERF07160	700	1600	750	725	105	170	130	158	9	74	140	C Type
1035-RERF07200	700	2000	750	725	105	170	130	178	9	74	140	C Type
1035-RERF08160	800	1600	850	825	105	170	130	178	10	74	140	C Type
1035-RERF08200	800	2000	850	825	105	170	130	188	10	74	140	C Type
1035-RERF09160	900	1600	950	925	105	170	130	218	11	74	140	C Type
1035-RERF09200	900	2000	950	925	105	170	130	248	11	74	140	C Type

1035

- Klappbar nach rechts oder links
- Die Distanz der Montage der Modelle RE und RF muss größer als das Maß C sein.

Product Nr. 1035 Die Arm Model RE-RF

- Itself can be turned left or right for storage.
- The distance for installing the two arms of Model RE and RF should be more than the distance between the installations (C)



**Modell RE Klappbar
Model RE Folding**



**Modell RF Klappbar
Model RF Folding**

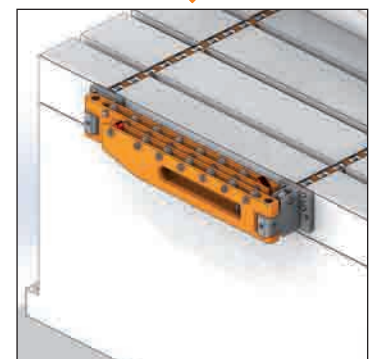
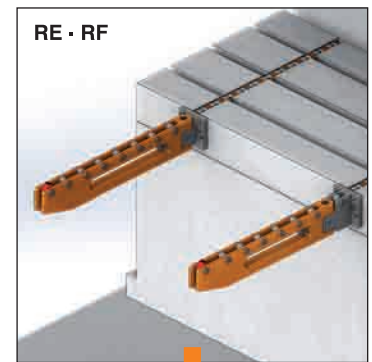
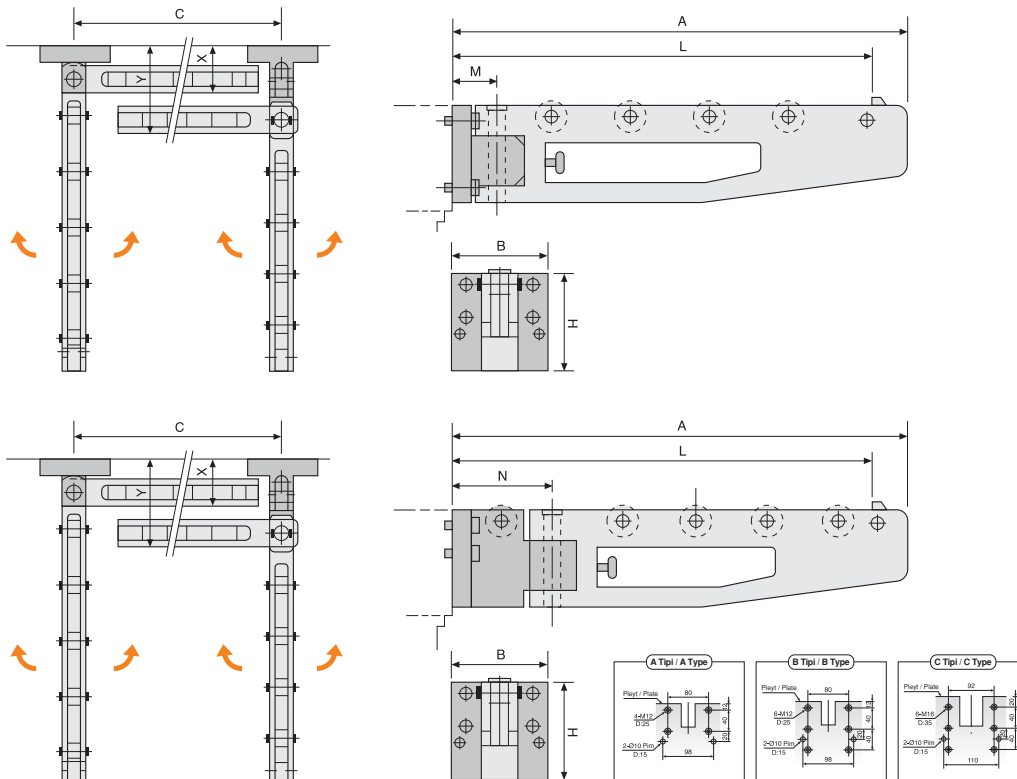

Modell / Model RS (Stütze / Supporter)



Modellauswahl / Model Selection



Verwendete Länge
Use length

Höhe zwischen
Platte und Boden
The height between the
plate and the ground

Werkzeuggewicht
Die weight

**1037 Werkzeugschiebearm Modell RS
1037 Die Arm Model RS**

- Bei Bestellung bitte obige Werte angeben.
- Übernehmen Sie das Lochbild Typ (D) für die Installation.
- Please clearly indicate the above information while ordering.
- Adopt (D) type to install hole pattern.

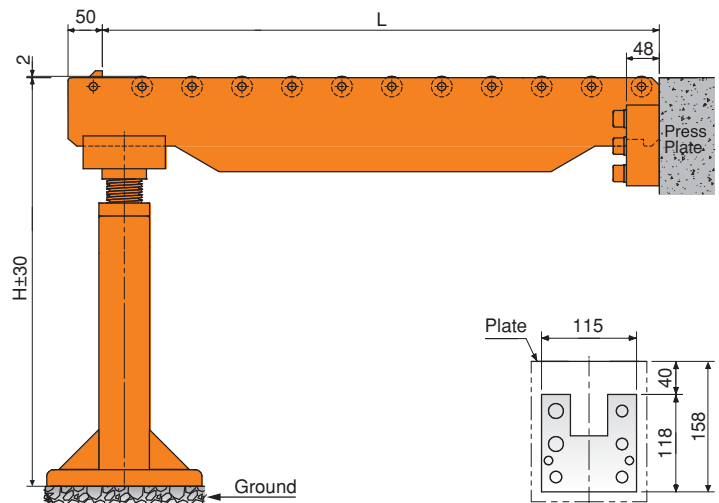

**LOCHSCHABLONEN
HOLE PATTERN FOR INSTALLATION**

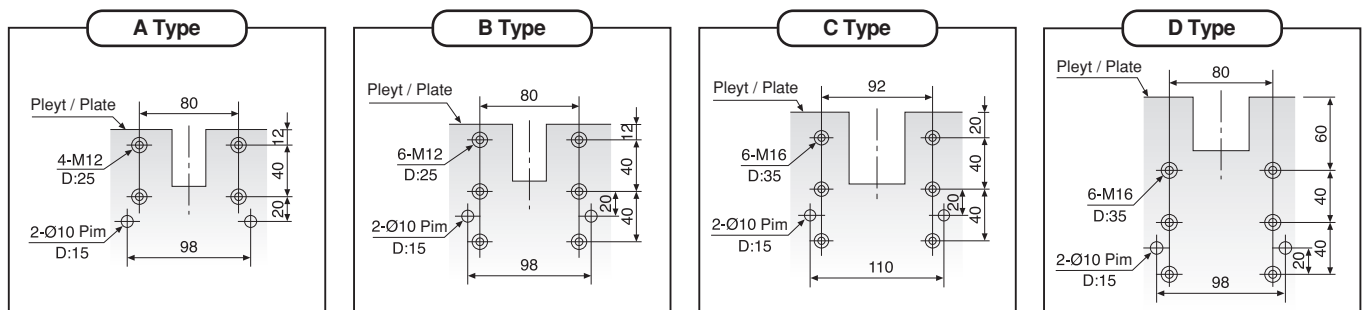

**Zubehör
Accessories**

Schlauchverbinder
Tube Connector
1036BT

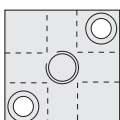

Drehgelenk
Rotary Joint
1036DE



Spannbügel
Clamp Bracket
1036CA



Spannbügel
Clamp Bracket
1036CB



Referenz-Nr. Order No.	L1	L2	H	 (kg)
1040-PB0801P1V	250	225	367	15.55
1040-PB0801P2V	310	285	367	18.55
1040-PB0801P3V	428	403	367	21.50
1040-PB0801P4V	487	462	367	24.70
1040-PC1201P3V	-	397	367	-



1040

- Wenn der hydraulische Druck den vorgegebenen Wert erreicht hat, wird die Pumpe ausgeschaltet, um Energie zu sparen. Auf der anderen Seite, wenn der Arbeitsdruck niedriger wird, wird der Luftdruck automatisch wiedergegeben.
- Der Steuerkreis prüft und verhindert evtl. Undichtheiten. Auch wenn der pneumatische Druck aussetzt, wird der hydraulische Druck aufrecht erhalten.
- Druckprüfung und Eigenschaft Spannen an die Maschinen ist vorhanden.
- Bei Anwendung mit CA und CB-16 oder 25 Spannsystem wird das Pumpenmodell PC12 empfohlen.
- Kapazität 500 max. bar
- Druckregelventil

1040

- The hydraulic pump is driven by air. Once the hydraulic pressure reaches the pressure setting, it stops pumping which is energy saving. Meanwhile, if the working pressure reduces, the pump would supply pressure automatically to keep working pressure continuously.
- The circuit control system is designed with the function of checking and avoiding oil leakage. If pneumatic pressure out, the hydraulic pressure still maintains.
- It is capable of pressure inspection and connecting to machines.
- It is suggested to adopt pump model PC12 when used with clamp model CA&CB-16 or 25.
- Capacity 400 max. bar
- Pressure control valve

Modellauswahl / Model Selection

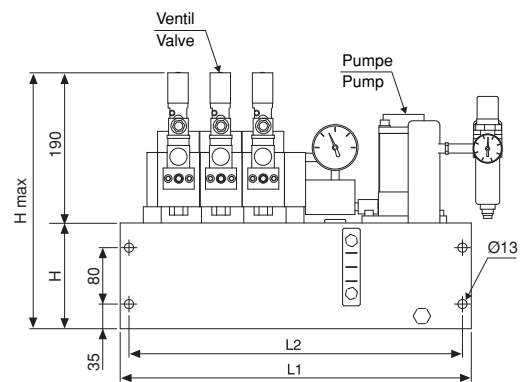
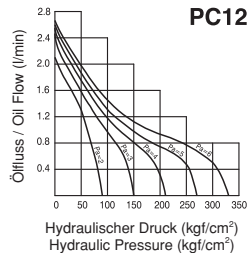
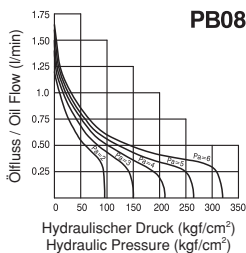
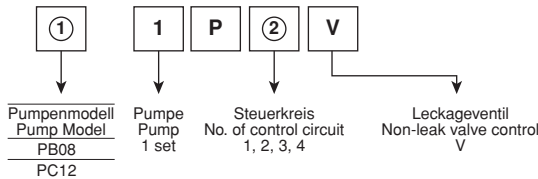

Referenz-Nr. Order No.
1040-PB0101

1040

- Wird nur der Werkzeugheber benutzt, kann alternative eine hydraulische Handpumpe verwendet werden.
- 250 Bar

1040

- If only the die lifter is used, the usage of a manual hydraulic pump can alternatively be used.
- 250 Bar

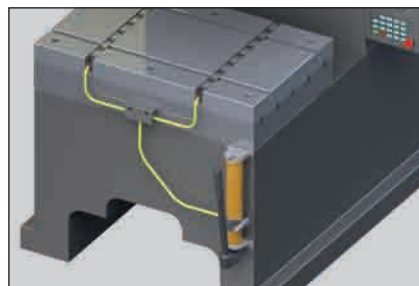

alternatives System
Alternative Systems

Hydraulische Handpumpe Hydraulic Hand Pump



Referenz-Nr. Order No.	Schaltkreis Circuits
1041-QDC01	1
1041-QDC02	2
1041-QDC03	3
1041-QDC04	4

1041

Steuergerät Control Unit





Referenz-Nr. Order No.	Ventil Valve	Durchfluss Flow		bar
		(l/min)	(l/min)	
1040-1P1VD	1	6	14	150
1040-1P2VD	2	6	14	150
1040-1P3VD	3	6	14	150
1040-1P4VD	4	6	14	150

1040

- Es ist für ein Direktanschluss-System geeignet.
- Bitte geben Sie vor dem Kauf die gewünschte Durchflussgeschwindigkeit (l/min) an.

1040

- It is suitable for direct connection system.
- Please, you specify about flow speed (l/minute) before make purchase.

Elektrisches Hydraulik-Aggregat



Referenz-Nr. Order No.	Ventil Valve	Durchfluss Flow		bar
		(l/min)	(l/min)	
1040-1P1V	1	6	14	150
1040-1P2V	2	6	14	150
1040-1P3V	3	6	14	150
1040-1P4V	4	6	14	150

1040

- Es ist für die Schnellkupplung geeignet.
- Bitte geben Sie vor dem Kauf die gewünschte Durchflussgeschwindigkeit (l/min) an.

1040

- It is suitable for quick coupling.
- Please, you specify about flow speed (l/minute) before make purchase.

Modulare Schnellkupplung

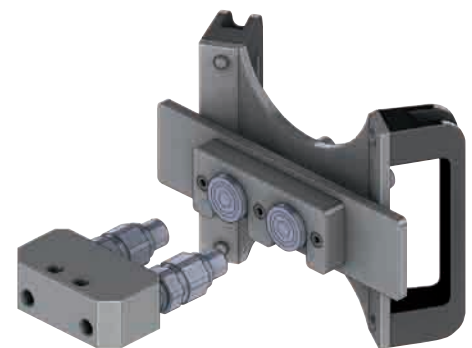

Referenz-Nr. Order No.
1042-02

1042

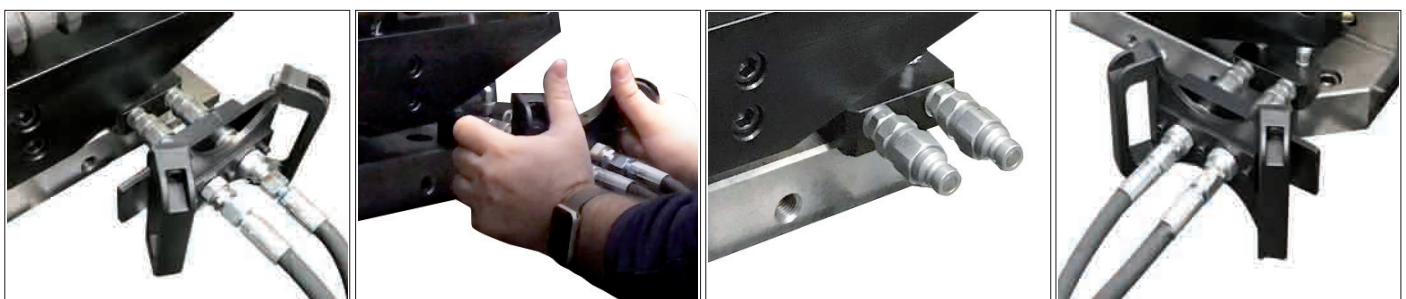

Hydraulik-Komponenten

Hydraulic Components



Anwendung

Der hydraulische Schwenkspanner ist die beste Auswahl, wenn Werkstücke frei zugänglich eingelegt werden müssen und höhere Spannkraften in Spanneinrichtungen benötigt sind.

Funktion

Der Zylinder hat Zieh-Eigenschaft. Der Gesamthub entspricht dem Dreh- und Ziehhub.

Type

Der Zylinder übt Druck nach unten aus. Er bewegt sich im Uhrzeigersinn und umgekehrt. Standardwinkel ist 90°, optional 0°-45° und 60°.

Material

Der Grundkörper ist aus Aluminiumlegierung.



Application

When machining a workpiece by means of a machine tool, a hydraulic swing clamping cylinder will be your best choice if the placing and taking of the workpiece are not allowed to be interfered by the clammer and need a larger clamping force.

Function

This cylinder belongs to a pull cylinder of which the total stroke is equal to the sum of a swing stroke and a clamping stroke, and is usually used within the clamping stroke.

Type

This swing cylinder belongs to a double-acting type which is operated mainly in a downward pressing manner, including clockwise swing and counterclockwise swing; standard angle is 90°, and optional angles include 0°, 45°, 60°; clamping means includes single arm or double arms; the mounting manner includes threaded type and lower flange type for manifold mounting with O-ring seal.

Material

This material of the main body is aluminum alloy.



Bestellbeispiel / Ordering example

Referenz-Nr. Order No.	NHS Basis-Nr. Base No.	T Type Flansch Flange T: verzahnt T: Threaded	D Arm Type D: Doppelarm D: Double Arm Leer : Einzelbewegung Blank: Single Arm	L – Drehrichtung Swivel Direction L: links L: Left R: rechts R: Right	40 Kolben / Piston Ø 25 32 40 50 63	x 90° – Winkel / Angle 0° 45° 60° 90° 180°
---------------------------	------------------------------	--	--	---	---	--

Schematische Übersicht theoretischer Spannkraften unter unterschiedlichem Hydraulik-Druck

Schematic view showing a theoretical clamping force under different hydraulic pressure:

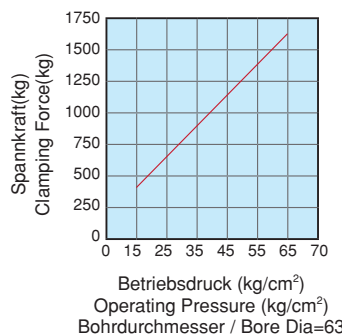
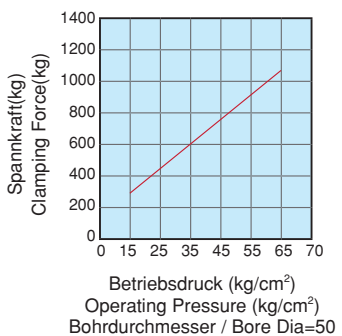
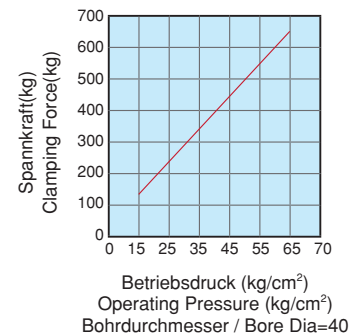
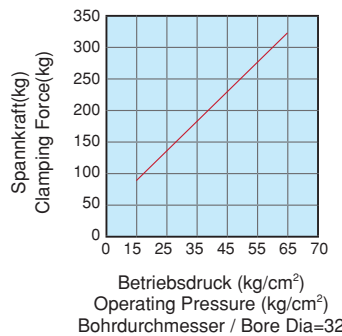
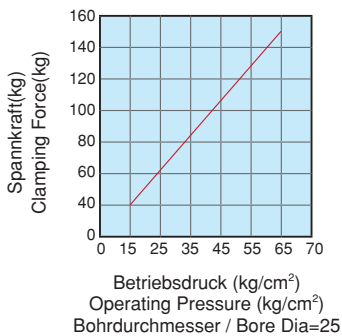

Referenz-Nr. Order No.	Spann-Type Mounting Type	Spannarm Clamping Arm	Max. Druck Max. Pressure	Normaldruck Normal Pres.	Bewegungs-Type Acting Type	Drehwinkel Swivel Angle	Drehhub Swivel Stroke (mm)	Spannhub Clamp Str. (mm)	Bohrdurchmesser Diameter Ø (mm)	Kolbenstange Piston Rod Ø	Spannkraft Force (25kg/cm ²)	A (mm) Lösen Unclamp	B (mm)	C (mm)	D (mm)	G (mm)	H (mm)	L1 Spannen/Clamp L2 Lösen/Unclamp	N (mm)	P (mm)	Q (mm)	R (mm)	S (mm)	O-Ring/ Manifold O-Ring	M (mm)	F (mm)	Gewicht Weight (kg)							
1043-NHS025	Bottom Flange	1-Arm / Single Arm	70 kg/cm ²	20-45 kg/cm ²	doppelseitige Bewegung / Double Acting	90° (0° 45°, 60°, 180°) ± 2°	12	14	25	18	59	100	70	23	□ 25.4	50	10	1/8 PF	M10 x1.5	40	50	6.5	45	Ø	Ø	S4	18	15	0.8					
1043-NHS032							14	15	32	20	125	111	76	25	□ 25.4	55	10	1/8 PF	M10 x1.5	44	55	10	1/8 PF	M10 x1.5	44	55	6.5	50	Ø	Ø	S4	24	17	1.0
1043-NHS040							14	15	40	20	200	113.6	80	27	□ 25.4	55	10	1/8 PF	M10 x1.5	48	62	10	1/8 PF	M10 x1.5	48	62	8.5	54	Ø	Ø	S4	26	20	1.1
1043-NHS050							14	15	50	20	400	114.5	80	27	□ 25.4	55	10	1/8 PF	M10 x1.5	57	74	10	1/8 PF	M10 x1.5	57	74	8.5	65	Ø	Ø	S4	30	25	1.4
1043-NHS063							14	15	63	25	600	118	85	32	□ 32	75	11	1/8 PF	M12 x1.75	70	88	11	1/8 PF	M12 x1.75	70	88	10.5	80	Ø	Ø	S4	40	30	2.3

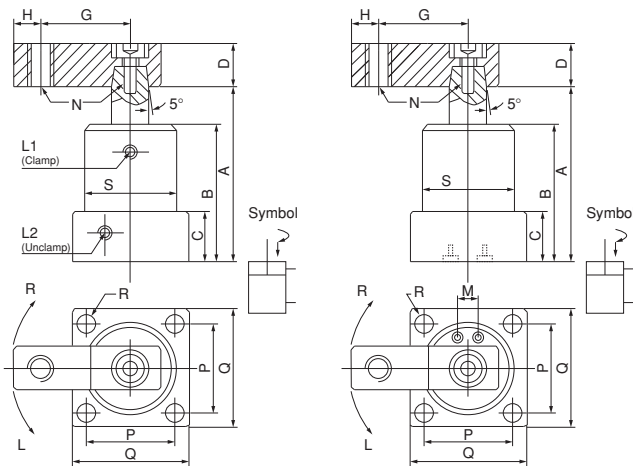

1043

NHS – Flanschversion, 1-Arm
Mit Rohr oder Verteiler

NHS – Flange Version, Single Arm
With Pipe or Manifold

- Bei Bestellung bitte Bewegungs-Type und Drehwinkel angeben.
- Before buying please, movement indicate the type and rotation angle.



Referenz-Nr. Order No.	Spann-Type Mounting Type	Spannarm Clamping Arm	Max. Druck Max. Pressure	Normaldruck Normal Pres.	Bewegungs-Type Acting Type	Drehwinkel Swivel Angle	Drehhub Swivel Stroke (mm)	Spannhub Clamp Str. (mm)	Bohrdurchmesser Diameter Ø (mm)	Kolbenstange Piston Rod Ø	Spannkraft/Clamp Force (25kg/cm ²)	A (mm) Lösen Unclamp	B (mm)	C (mm)	D (mm)	G (mm)	H (mm)	L1 Spannen/Clamp L2 Lösen/Unclamp	N (mm)	P (mm)	Q (mm)	R (mm)	S (mm)	O-Ring/ Manifold O-Ring	M (mm)	F (mm)	Gewicht Weight (kg)						
1045-NHSD025	Bottom Flange	2-Arm / Single Arm	70 kg/cm ²	20-45 kg/cm ²	doppelseitige Bewegung / Double Acting	90° (0° 45°, 60°, 180°) ± 2°	12	14	25	18	59	100	70	23	□ 19	100	1/8 PF	Ø 8	40	50	6.5	45	Ø	Ø	S4	18	15	0.9					
1045-NHSD032							14	15	32	20	125	111	76	25	□ 22	120	1/8 PF	Ø 8	44	55	120	1/8 PF	Ø 8	44	55	6.5	50	Ø	Ø	S4	24	17	1.1
1045-NHSD040							14	15	40	20	200	113.6	80	27	□ 22	120	1/8 PF	Ø 8	48	62	120	1/8 PF	Ø 8	48	62	8.5	54	Ø	Ø	S4	26	20	1.2
1045-NHSD050							14	15	50	20	400	114.5	80	27	□ 22	120	1/8 PF	Ø 8	57	74	120	1/8 PF	Ø 8	57	74	8.5	65	Ø	Ø	S4	30	25	1.5
1045-NHSD063							14	15	63	25	600	118	85	32	□ 25.4	140	1/8 PF	Ø 10	70	88	140	1/8 PF	Ø 10	70	88	10.5	80	Ø	Ø	S4	40	30	2.5

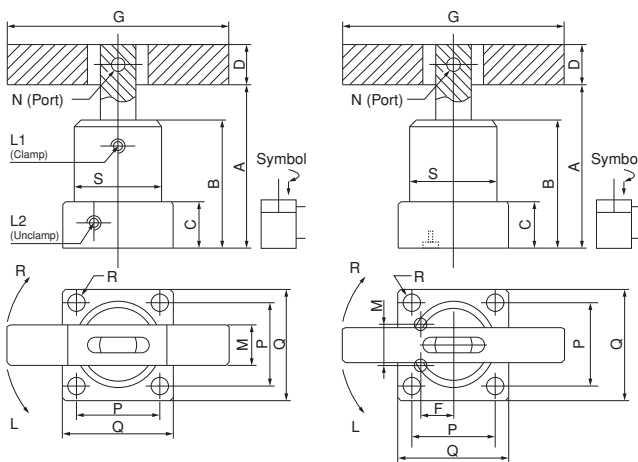

1045

NHSD – Flanschversion, Doppelarm
Mit Rohr oder Verteiler

NHSD – Flange Version, Double Arm
With Pipe or Manifold

- Bei Bestellung bitte Bewegungs-Type und Drehwinkel angeben.
- Before buying please, movement indicate the type and rotation angle.



Referenz-Nr. Order No.	Spann-Type Mounting Type	Spannarm Clamping Arm	Max. Druck Max. Pressure	Normaldruck Normal Pres.	Bewegungs-Type Acting Type	Drehwinkel Swivel Angle	Drehhub Swivel Stroke (mm)	Spannhub Clamp Str. (mm)	Bohrdurchmesser/ Bore Diameter Ø (mm)	Kolbenstange Piston Rod Ø	Spannkraft/Clamp Force (25kg/cm ²)	A (mm) Lösen Unclamp	B (mm)	C (mm)	D (mm)	G (mm)	H (mm)	I (mm)	L1 Spannen / Clamp L2 Lösen / Unclamp	N (mm)	S (mm)	T (mm) Korkmutter 2 St. T (mm) 2 pcs/set	Y (mm)	Gewicht Weight (kg)	
1047-NHTS025	verzahnter Körper / Threaded Body	1-Arm / Single Arm	70 kg/cm ²	20-45 kg/cm ²	doppelseitige Bewegung / Double Acting	90° (0° 45°, 60°, 180°) ± 2°	12	14	25	18	59	100	70	35	□	25.4	50	10	9	1/8 PF	M10 x1.5	M45 x1.5	Ø 65	10	0.8
1047-NHTS032							14	15	32	20	125	111	76	45	□	25.4	55	10	9	1/8 PF	M10 x1.5	M50 x1.5	Ø 70	11	1.1
1047-NHTS040							14	15	40	20	200	113.6	80	45	□	25.4	55	10	9	1/8 PF	M10 x1.5	M55 x1.5	Ø 75	11	1.25
1047-NHTS050							14	14	50	20	400	120	87	50	□	25.4	55	10	9	1/8 PF	M10 x1.5	M65 x1.5	Ø 85	12	1.7

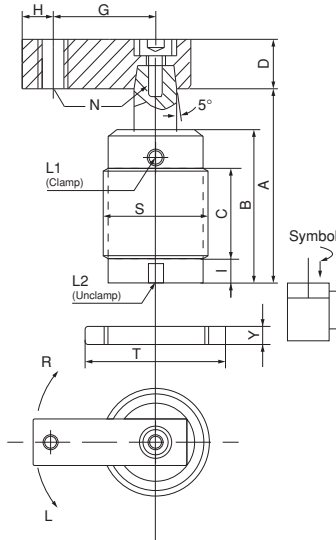

1047

NHTS – Verzahnte Version, 1-Arm
Mit Rohr

NHTS – Threaded Version, Single Arm
With Pipe

- Bei Bestellung bitte Bewegungs-Type und Drehwinkel angeben.
- Before buying please, movement indicate the type and rotation angle.



Hydraulischer Schwenkspanner

Hydraulic Swing Clamp

Referenz-Nr. Order No.	Spann-Type Mounting Type	Spannarm Clamping Arm	Max. Druck Max. Pressure	Normaldruck Normal Pres.	Bewegungs-Type Acting Type	Drehwinkel Swivel Angle	Drehhub Swivel Stroke (mm)	Spannhub Clamp Str. (mm)	Bohrdurchmesser/ Bore Diameter Ø (mm)	Kolbenstange Piston Rod Ø	Spannkraft/Clamp Force (25kg/cm ²)	A (mm) Lösen Unclamp	B (mm)	C (mm)	D (mm)	G (mm)	I (mm)	L1 Spannen / Clamp L2 Lösen / Unclamp	N (mm)	S (mm)	T (mm) Korkmutter 2 St. T (mm) 2 pcs/set	Y (mm)	Gewicht Weight (kg)	
1050-NHTSD-25	verzahnter Körper / Threaded Body	2-Arm / Double Arm	70 kg/cm ²	20-45 kg/cm ²	doppelseitige Bewegung / Double Acting	90° (0° 45°, 60°, 180°) ± 2°	12	14	25	18	59	100	70	35	□	19	100	9	1/8 PT	Ø 8	M45 x1.5	Ø 65	10	0.9
1050-NHTSD-32							14	15	32	20	125	111	76	45	□	22	120	10	1/8 PT	Ø 8	M50 x1.5	Ø 70	11	1.2
1050-NHTSD-40							14	15	40	20	200	113.6	80	45	□	22	120	10	1/8 PT	Ø 8	M55 x1.5	Ø 75	11	1.4
1050-NHTSD-50							14	14	50	20	400	120	87	50	□	22	120	10	1/8 PT	Ø 8	M65 x1.5	Ø 85	12	1.85

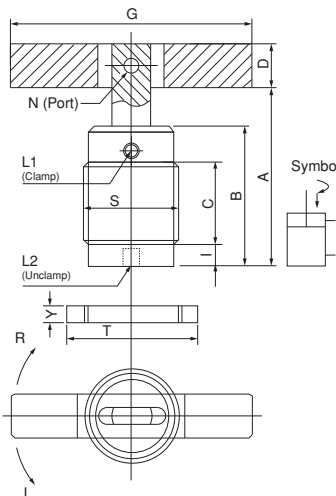

1050

NHTSD – Verzahnte Version, Doppelarm
Mit Rohr

NHTSD – Threaded Version, Double Arm
With Pipe

- Bei Bestellung bitte Bewegungs-Type und Drehwinkel angeben.
- Before buying please, movement indicate the type and rotation angle.



Referenz-Nr. Order No.	A (mm)	B (mm)	C (mm)	D (mm)	E (mm)	F (mm)	G (mm)	H (mm)	J (mm)	K (mm)	M (mm)	N (mm)	P (mm)	Q (mm)	R (mm)	T (mm)	Z (mm)	A1 (mm)	L1 (mm)	N1 (mm)	(g)
1051-VS035	129	61	51	48	80	52	28	35.5	25.5	40	12	30	3	9.5	5.5	16	22	65.5	42	M6	0.84
1051-VS042	146	69	60	55	87	59	28	39	30	47	12	33.5	3	11	6.5	18.5	24	77	50	M8	1.25
1051-VS050	153	81	70	65	93	63	30	46	35	55	13	39.5	5	11	6.5	20	30	91.5	56.5	M10	1.86
1051-VS060	179	92	80	75	108	71	37	52	40	63	16	45	5	14	8.5	23.5	32	105	65	M12	2.86
1051-VS074	192	107	95	90	114	74	40	59.5	47.5	75	16	52.5	5	17.5	10.5	25	37	127	75	M16	4.75

Referenz-Nr. Order No.	Zylinderfläche cm ² Cylinder Area cm ²	Gesamthub Total Stroke	Spannhub Clamp Stroke	Drehhub Swivel Stroke	Ölvolumen cm ³ / Spannen Cylinder Volume cm ³ /Clamp	Ölvolumen cm ³ / Entspannen Cylinder Volume cm ³ /Release	Spannkraft 70 kg/cm ² Clamping Force at 70 kg/cm ²	Min./Max. Betriebsdruck kg /cm ² Min./Max. Operating Pressure kg /cm ²	Arbeitstemperatur Operating Temperature	90° Drehwinkel Toleranz 90° Swing Angle Tolerance	Wiederholgenauigkeit Clamp-Swing Position Repeat Tolerance
1051-VS035	5.8	22	8	14	12.8	21.2	405	5 - 70	0-70°	90±2°	0.5°
1051-VS042	8.9	25	10	15	22.4	34.6	625	5 - 70	0-70°	90±2°	0.5°
1051-VS050	12.6	26	10	16	32.7	51.0	880	5 - 70	0-70°	90±2°	0.5°
1051-VS060	18.4	29	12	17	53.3	82.0	1285	5 - 70	0-70°	90±2°	0.5°
1051-VS074	27.1	30	12	18	81.3	129.0	1896	5 - 70	0-70°	90±2°	0.5°

1051

Mit Rohr und Verteiler With Pipe and Manifold

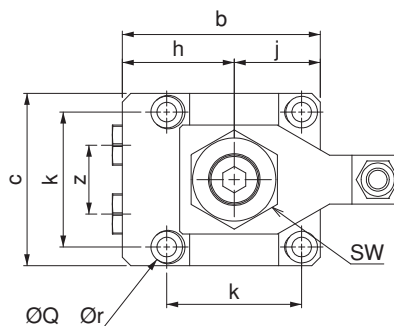
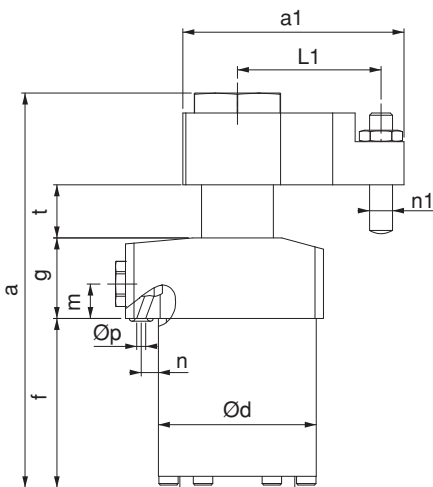

Referenz-Nr. Order No.	A	B	C	E	F	G
1051-VS035	40	M5	48	30	22	3
1051-VS042	47	M6	55	33.5	24	3
1051-VS050	55	M6	65	39.5	30	5
1051-VS060	63	M8	75	45	32	5
1051-VS074	75	M10	90	52.5	37	5

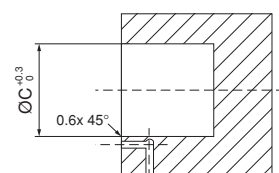
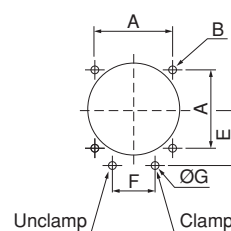

Referenz-Nr. Order No.	Gesamthub Total Stroke (mm)	Spannhub Lock Stroke (mm)	Extrahub Extra Stroke (mm)	Max. Druck Max. operating pressure kg/cm	Min. Druck Min. operating pressure kg/cm	Spannkraft Clamping Force (at 70 kg/cm ²)	Arbeitstemperatur Operating Temperature	 (kg)
1052-VT25S	23.5	20.5	3	70	20	280kg	0 - 70°C	0.60
1052-VT32S	26	23	3	70	20	448kg	0 - 70°C	0.92
1052-VT40S	29.5	26.5	3	70	20	700kg	0 - 70°C	1.86
1052-VT50S	35	32	3	70	20	1092kg	0 - 70°C	2.34
1052-VT63S	41	38	3	70	20	1736kg	0 - 70°C	3.90



1052

• 1052-VT63S codierte Produkte sind mit Verteiler und Ölfluss, das Öl ist regenerierend.

1052

• 1052-VT63S coded products manifold and oil flow, oil is reflexive.

Mit Rohr und Verteiler
With Pipe and Manifold

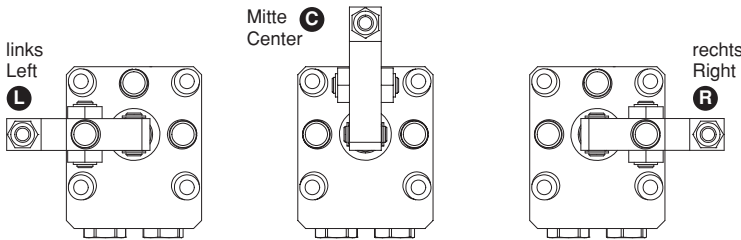

Referenz-Nr. Order No.	A	B	C	E	F	G
1052-VT25S	40	M5x0.8	48	30	11	3
1052-VT32S	47	M6	55	33.5	12	3
1052-VT40S	55	M6	65	39.5	15	5
1052-VT50S	63	M8	75	45	16	5
1052-VT63S	75	M10	90	52.5	18.5	5

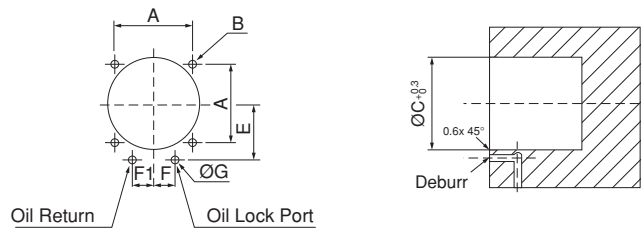

VT63S

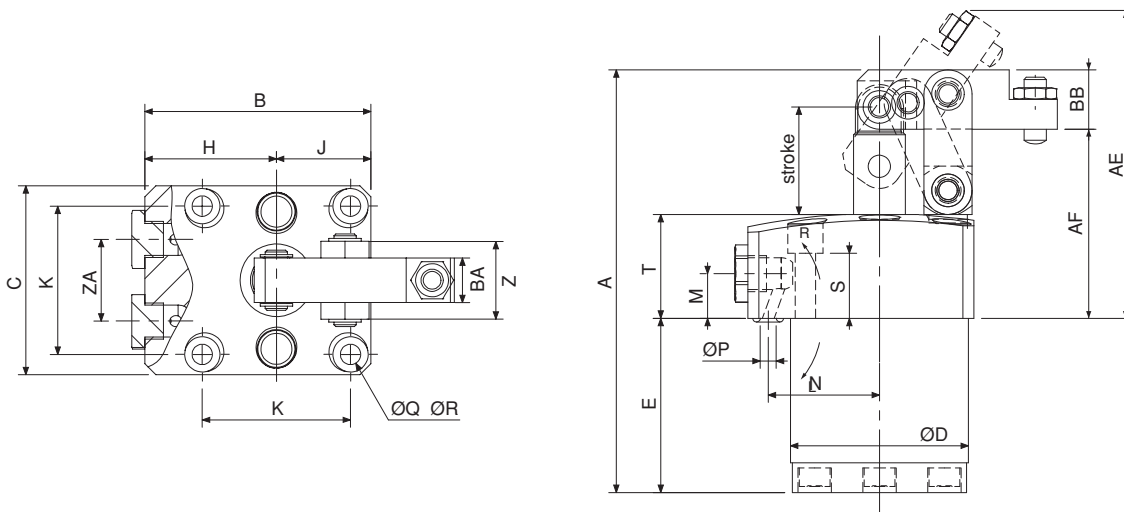

Referenz-Nr. Order No.	A	B	C	D	E	H	J	K	M	N	S	T	Z	part	ZA	Spanneisen Clamping Arm				ØQ	ØR
																AE	AF	BA	BB		
1052-VT25S	114	61	51	48	75	35.5	25.5	40	12	30	17.5	35	21	G1/8	22	92.4	51	12	16	9.5	5.5
1052-VT32S	132.5	69	60	55	87	39	30	47	12	33.5	15	37.5	28	G1/8	24	101.9	53.5	16	20	11	6.8
1052-VT40S	147	81	70	65	93	46	35	55	13	39.5	15.5	45	37	G1/4	30	111.4	59	19	25	11	6.8
1052-VT50S	175	94.5	85	75	108	52	42.5	63	16	45	19.5	55	40	G1/4	32	130.8	72	22	32	14	9
1052-VT63S	207	109.5	100	90	128	59.5	50	75	16	52.5	19	64.5	49	G3/8	37	146.5	81	25	38	17.5	11

Beschreibung

Dieser Einschraubzylinder wird in den ausgefahrenen Zustand gebracht und übt innerhalb eines Hubs eine Spannkraft auf ein Werkstück aus, um das Werkstück zu sichern. Die Montageweise dieses Einschraubzylinders ist in der folgenden Zeichnung dargestellt, die die empfohlenen Abmessungen der Geräte veranschaulicht, und diese Montage erfordert eine Teflondichtung, um Ölleckagen zu vermeiden.

Description

This threaded-body clamping cylinder is applied to a condition of knocking-out, and applies a clamping force on a workpiece within a stroke in order to secure the workpiece. The mounting manner for this threaded-body clamping cylinder is shown as the following drawing illustrating suggested dimensions of devices, and this mounting needs a Teflon packing in order to avoid oil leakage.



Bestellbeispiel / Ordering example

Nr. 1053 **TC** **12** **A**
 Basis Nr. Kolben Ø Serie / Series
 Base No.

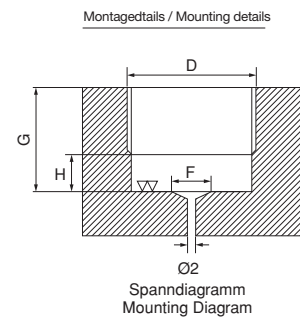
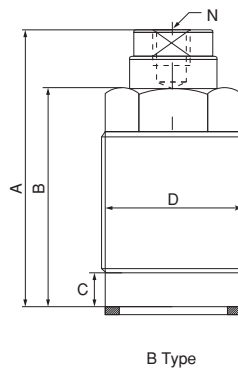
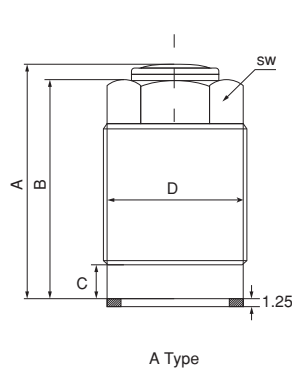

Referenz-Nr. Order No.	Arbeits-Öldruck Operating Oil Pressure	Bewegungs-Type Acting Type	Hub Stroke S (mm)	Kolbenstange Piston Rod Ø (mm)	Spannkraft/Clamp Force (200kg/cm ²)	A (mm)	B (mm)	C (mm)	D (mm)	F (mm)	G (mm)	H (mm)	N (mm)	sw	Gewicht, Weight (kg)
1053-TC12A	20-350 kg/cm ²	einfachwirkend / Single Acting	10	12	200 (kg)	38	36	7	M22 x1.5	12	16	6	-	17	0.07
1053-TC16A			12	16	400 (kg)	46.5	44.5	8	M26 x1.5	16	20	7	-	22	0.14
1053-TC-20A			15	20	620 (kg)	56	54	8	M30 x1.5	20	24	7	-	24	0.22
1053-TC25A			16	25	980 (kg)	57	55	11	M38 x1.5	25	28	10	-	32	0.37
1053-TC12B			10	12	200 (kg)	45	36	7	M22 x1.5	12	16	6	M6x1	17	0.08
1053-TC16B			12	16	400 (kg)	52	44.5	8	M26 x1.5	16	20	7	M6x1	22	0.15
1053-TC20B			15	20	620 (kg)	64.5	54	8	M30 x1.5	20	24	7	M8x1.25	24	0.24
1053-TC25B			16	25	980 (kg)	67	55	11	M38 x1.5	25	28	10	M8x1.25	32	0.4

Referenz-Nr. Order No.	Hub Stroke (mm)		Zylinderkraft(kN) / Cylinder Force(kN)				Zylinderdurchmesser (mm) Cyl. inner dia. (mm)	Stangendurchmesser (mm) Rod dia. (mm)	Wirkungsfläche (cm ²) Effec. area (cm ²)	Max. Ölflussfläche (l/min) Max. oil flow rate(l/min)	Zylinderkapazität (cm ³) Cylinder cap.(cm ³)		Rückkehr Federkraft (N) Return spring force (N)	Spannkraft Clamp Force (200kg/cm ²)
			Hydraulikdruck Hydraulic Press. 3.5 MPa	Hydraulikdruck Hydraulic Press. 7 MPa	Hydraulikdruck Hydraulic Press. 25 MPa	Hydraulikdruck Hydraulic Press. 35 MPa								
1055-CMD02	5	10	0.3	0.5	2.1	2.9	16	10	0.84	0.25	0.5	0.9	30~56	245
1055-CMD04	5	10	0.4	0.9	3.4	4.8	18	10	1.37	0.41	0.7	1.4	43~77	351
1055-CMD06	10	20	0.7	1.5	5.6	7.9	22	12	2.29	0.69	2.3	4.6	65~120	533
1055-CMD10	10	20	1.2	2.5	9.3	13	28	16	3.76	1.13	3.8	7.5	100~193	828
1055-CMD20	10	20	2	4.3	15.8	22.2	36	20	6.40	1.92	6.4	12.8	170~267	1400

1055

Bestellbeispiel
Ordering example

Nr. 1055

CMD

02
Serie / Series

16
Kolben Ø
Piston Ø

5
Hub / Stroke



Technische Daten / Technical Dimensions

	Hub (mm) Stroke (mm)		B	C	D	E	F	G	(hex Weite) (hex width across flats)		(Körper mit Gewinde) (ly section thread)	(Einschraub) (threaded body)	P	Q	R	S	T	(Hydr. Verbindung) (hydraulic connection port)	U	V	W	X	Y	O-Ring Z	O-Ring ZZ		
									sw	M1																M2	
CMD02	5	10	10	20.3	51	65	10	15	7.5	27	36	17	M6×1 depth 11	M22 ×1.5	6.5	20.5	13	32.5	41.5	5.5	3	5	7	4	3	P6	AS568-017
CMD04	5	10	10	23.3	51	65	10	15	8	26.5	35.5	19	M6×1 depth 11	M25 ×1.5	6.5	23.5	14	32	41	5.5	3	5	7.5	4	3	P6	AS568-019
CMD06	10	20	12	28.3	69	96	16	26	9.5	35.5	52.5	24	M8×1.25 depth 18	M30 ×1.5	8	28.5	15	42.5	59.5	7	3	5	9.5	4	3	P6	AS568-022
CMD10	10	20	16	34.3	73	101	17	27	11.5	35.5	53.5	30	M10×1.5 depth 20	M36 ×1.5	9	34.5	17	43.5	61.5	8	4	5	12	4	3	P6	AS568-026
CMD20	10	20	20	46.3	80	109	19	29	13.5	35.5	54.5	41	M12×1.75 depth 22	M48 ×1.5	12	46.5	20	46.5	65.5	11	6	7	15	4	3	P8	AS568-031

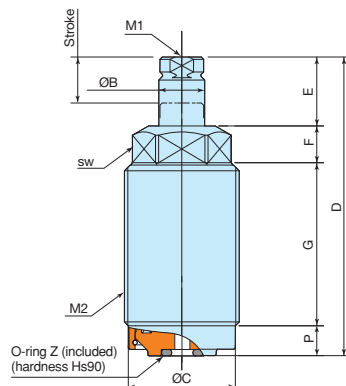

Montagedetails / Mounting details

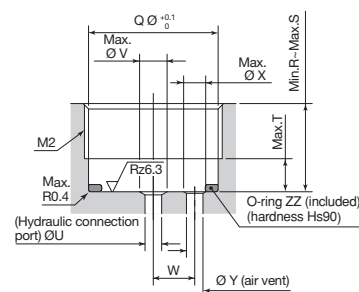

Referenz-Nr. Order No.	Stützkraft bei 70kg/cm ² Support Force	Hub Stroke	Max. Druck Max. Pressure	Normaldruck Normal Pressure	Anlegekraft Contact force	A	B	C	D	E	F	G	H	I	J	K	M	N	O	P	Q	R	S	CA	CB	CC	Gewicht Weight (kg)	
1056-WST26BL	200 kg	6	105 kg/cm ²	25 - 70 kg/cm ²	0.67	66	48	6.5	9	5	4	24	9	10	-	-	-	M6 x9D	-	24	26	10	M26 x1	M26 x1	20-30	2	0.20	
1056-WST30BL	300 kg	8			0.96	73	53	9.5	9	7	4	27	8	10	-	-	-	-	M6 x9D	-	28	30	10	M30 x1.5	M26 x1.5	20-50	9	0.25
1056-WST36BL	360 kg	8			2.12	69	50	9.5	8	7	4	32	11	10	-	-	-	-	M8 x11D	-	34.2	36	13	M36 x1.5	M26 x1.5	20-48	8	0.35
1056-WSU40BL	360 kg	8			1.82	67	31	25	14.5	7	4	-	11	12	22.5	31.5	5.5	5.5	M10 x8	26	34	45	13	Ø40	Ø40	-	-	0.60
1056-WSU48BL	720 kg	10			2.16	75	39	23	13.5	9	4	-	12	11	25.5	35.5	5.5	5.5	M10 x8	30	40	51	14	Ø48	Ø48	-	-	0.80
1056-WSU55BL	840 kg	12			1.33	85	45	23	11.5	11	6	-	15	14	30.5	39	6.8	6.8	M10 x10	33.5	47	60	18	Ø55	Ø55	-	-	1.40
1056-WSU65BL	1200 kg	14			1.05	101	56	27	14.5	12	6	-	17	14	35	46	6.8	6.8	M10 x10	40.5	55	70	20	Ø55	Ø55	-	-	2.20

1056

Niederdruck-Abstützelement

- der Betriebsdruck ist 25-70 kg/cm², mit Kopfflansch und einschraubbar
- Die Einlassöffnung ist kleiner, um die Geschwindigkeit des Kolbens zu verringern.

Wichtiger Hinweis zur Benutzung von Abstützelementen

- Reinheit des Hydrauliköls: Die inneren Teile des Abstützelements sind sehr präzise, deshalb ist die Reinheit des Öls ein sehr wichtiges Thema, das den Lebenszyklus beeinflussen kann. Eine schlechte Qualität des Öls wird zu geringerer Stützkraft führen. Normalerweise wird das Abstützelement wieder gut funktionieren, nachdem wir das Hydrauliköl gereinigt haben. In wenigen Bedingungen müssen wir das Abstützelement demontieren und die inneren Teile reinigen und die Öldichtung ersetzen.
- Reinigen Sie den Zylinderkörper: Die Metallverunreinigungen können während der Bearbeitung in das Innere gelangen, bitte reinigen Sie sie nach jeder Bearbeitung mit einer Luftpistole.
- Vermeiden Sie bitte folgendes oder der Abstützbolzen wird deformiert und der Kolben arbeitet nicht oder verliert die Stützkraft.



- A:** exzentrische Kraft auf den Kolben ausüben.
- B:** Last aufbringen, die die geschätzte Stützkraft übersteigt.
- C:** Den Kolben zu drehen, wenn in Stützposition

Work Support Low Pressure

- The operating range is 25-70 kg/cm², the mounting type includes thread body and upper flange, and we have piping mounting and manifold mounting in upper flange type.
- Inlet orifice is smaller, so it can reduce the speed of plunger when it is rising, it can reduce the impact onto workpiece, and reduce the tolerance which is caused by instant shock.

The important issue when you use work support

- The purity of hydraulic oil: the inner parts installed in work support are very precise, so the purity of hydraulic oil becomes a very important issue which can affect the life cycle of work support, bad quality of oil will cause to lose its supporting force. In usual, the work support will work well again after we clean the hydraulic oil, for few conditions, we need to disassemble the work support and clean the inner parts, even we need to replace oil seal.
- Clean the cylinder body: the metal impurity is possible going into the collet during the action, please make sure to clean by using an air gun after each machining.
- Please avoid the following condition, otherwise the collet will be deformed, and plunger will not work, or will lose supporting force.

- A:** Apply eccentric force onto plunger.
- B:** Apply an load which exceeds the estimated supporting force.
- C:** To turn the plunger when it is locked at supporting position

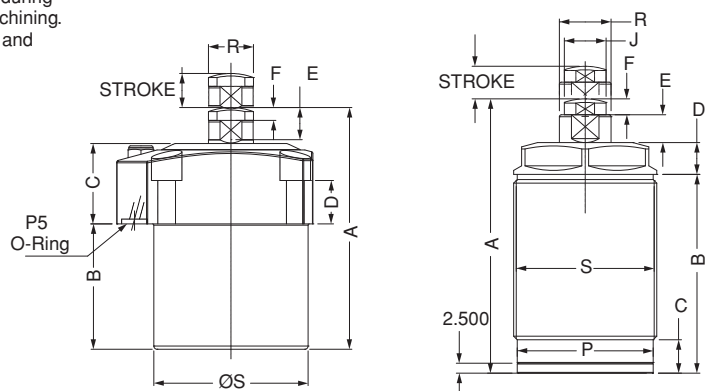
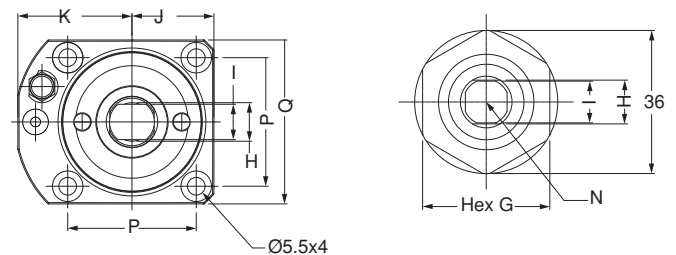

Montagedetails Mounting details

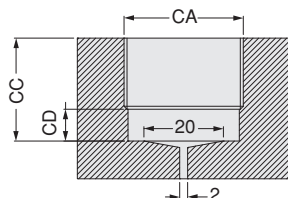

Referenz-Nr. Order No.	erweiterte Methode advanced method	Stützkraft bei 20 Mpa Supporting Force	Hub Stroke	Max. Druck Max. Pressure	Min. Druck Min. Pressure	Normaldruck Normal Pressure	Betriebstemperatur Operateure Operating Temperature	Anlegekraft / kg Contact force	A	B	C	C1	D	D1	D2	E	F	H1	H2	K	L	Q	U1	U2	O (O-ring)	Port	Gewicht Weight (kg)			
1056-WS16A	Spring	600 kgf	8	35 Mpa	5 Mpa	21 Mpa	0° ~ +70°	-	85.1	75.4	64.5	23.9	M35 x1.5	38.1	60.5	16	12.4	11.2	7.6	M10 x1.5	4.5	-	41.1	23.9	-	-	0.60			
1056-WS16B	Hidrolik Hydraulic	600 kgf	8					2.35	99.3	89.7	78.7	27.4	M35 x1.5	38.1	60.5	16	12.4	14.2	17.8	M10 x1.5	4.5	-	41.1	23.9	-	-	-	-	-	0.60
1056-WS30A	Spring	800 kgf	13					-	105	92	83	25	M60 x1.5	64	64	25	19	12.5	-	M10 x1.5	-	-	52	52	P7	G1/8	-	-	1.80	
1056-WS25B	Hidrolik Hydraulic	800 kgf	10.4					6.25	102.1	91.7	77.5	26.5	M50 x1.5	64	64	25	19	14	17.5	M16 x2	6	24.5	50	50	P7	G1/8	-	-	1.80	
1056-WS38A	Spring	1200 kgf	10.4					-	96.5	86.1	74.9	24.9	M68 x1.5	69.9	82.6	39	25.4	12.2	10.2	M20 x2.5	6.1	27.4	55.4	55.4	P10	G1/8	-	-	2.20	
1056-WS38B	Hidrolik Hydraulic	1200 kgf	10.4					8.86	102.1	91.7	78	26.4	M68 x1.5	69.9	82.6	38	25.4	13.7	13.2	M20 x2.5	6.1	27.4	55.4	55.4	P10	G1/8	-	-	2.20	

1056

Beschreibung

Das Abstützelement wird eingesetzt, um das Durchbiegen und Vibrieren der Werkstücke zu vermeiden.

Typen

Typ A: Ausfahren mit Federkraft; Eine Feder wird verwendet, um die Kontaktkraft zu steuern, wenn sich die Ausstoßstange bis in die höchste Ausstoßposition erstreckt und das Werkstück berührt.

Typ B: Ausfahren mit Öldruck; Wenn der Stützbolzen in tiefster Position ist, wird sie mittels Öldruck betätigt und beim Füllen mit Öl abgestossen und verwendet eine Feder, um die Kontaktkraft mit dem Werkstück zu steuern.

1056

Description

Hydraulic work support is used for avoiding deformation and decreasing vibration during machining.

Types

A type: knocking-out with a spring; the spring is used to control a contact force when the knocking out rod (piston rod) extends to a highest knocking-out position and contacts the workpiece.

B type: Knocking-out with oil pressure; when the knocking-out rod is at lowest position, it is operated by means of oil pressure and is knocked out when being filled with oil and uses a spring to control the contact force with the workpiece.

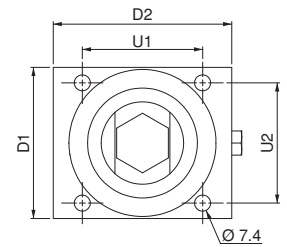
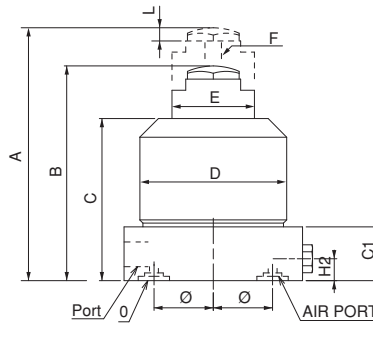
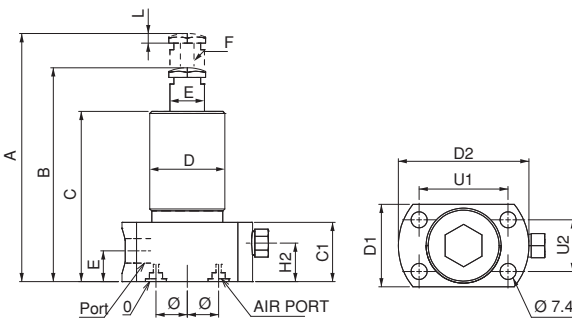

Referans Nr.	Betriebsdruck Operating Oil Pressure	Wirkungsart Acting Type	Hub Stroke	Kolbenstange Piston Rod Ø (mm)	Stützkraft 200kg/cm ² Supporting Force	Anlegekraft / kg Contact force	A	B	C	D	E	F	Gewicht Weight (kg)
1056-SP16A	100-350 kg/cm ²	Feder Spring	8	16	210 kg	-	79	54	8	M30 x1.5	11	8	0.30
1056-SP16B	100-350 kg/cm ²	Hydraulik Hydraulic	8	16	210 kg	2.35	72	54	8	M30 x1.5	11	8	0.30

1056

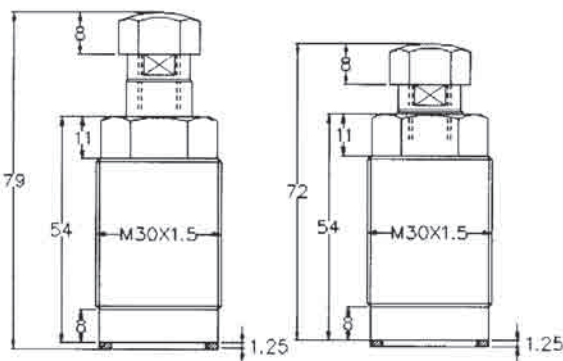

Montagedetails / Mounting details

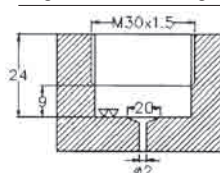

Hydraulisches Abstützelement

Hydraulic Work Support



SP16A

SP16B

Referenz-Nr. Order No.	Temperatur bis zu Temp. up to	Zylinder Piston Ø D (mm)	Kolbenstange Piston Rod Ø (mm)	Zug bei 100 bar Force to pull at 100 bar (kgf)	Zug bei 500 bar Force to pull at 500 bar (kgf)	Federückstellung Spring return force, min. (N)	Ölvolumen pro 10 mm Hub Oil volume per 10 mm stroke (cm ³)	a (mm)	b (mm)	c (mm)	f (mm)	g (mm)	h (mm)	k (mm)	m (mm)	n (mm)	o	p	r (mm)	s (mm)	t (mm)	SW (mm)	Hub Stroke ± 1 (mm)	I ± 1 (mm)	Gewicht Weight (kg)
1057-010016	100 °C	16	10	110	600	40	1.22	60	35	22	30	6.5	30	17.5	16.5	11	M6x12	G1/4	-	40	22	8	8	78	0.8
1057-015016	150 °C																								
1057-010025	100 °C	25	16	270	1430	140	2.90	65	45	27	50	8.5	33	22.5	18	11	M10x15	G1/4	-	50	30	13	8	91	1.2
1057-015025	150 °C																								
1057-010032	100 °C	32	20	460	2420	195	4.90	75	55	35	55	10.5	38	27.5	22	11	M12x15	G1/4	-	55	35	17	10	110	1.8
1057-015032	150 °C																								
1057-010040	100 °C	40	25	730	3790	270	7.65	85	63	35	63	10.5	40	31.5	24	11	M16x25	G1/4	4	63	40	-	10	114	2.6
1057-015040	150 °C																								
1057-010050	100 °C	50	32	1100	5730	440	11.60	100	75	35	76	13	44	37.5	27	13	M20x25	G1/4	4	76	45	-	12	125	3.8
1057-015050	150 °C																								
1057-010063	100 °C	63	40	1790	9230	430	18.60	125	95	44	95	17	50	47.5	26	17	M27x40	G1/2	4	95	65	-	12	146	6.7
1057-015063	150 °C																								
1057-010080	100 °C	80	50	2920	15180	760	30.63	160	120	46	120	21	60	60	34	21	M30x40	G1/2	5	120	80	-	12	193	12.8
1057-015080	150 °C																								
1057-100100	100 °C	100	63	4560	23500	1200	47.36	200	150	55	158	25	64	75	35	25	M42x60	G1/2	6	158	108	-	12	185	24
1057-150100	150 °C																								

1057

- Toleranzen für Längen- und Winkelmaße nach DIN 7168-m
- Tolerances for length and angle dimensions as per DIN 7168-m

wichtige Hinweise

Wenn die Möglichkeit besteht, dass aggressive Schneid- und Kühlmittel durch den Sintermetallluftfilter in das Zylinderinnere eindringen, muss ein Entlüftungsschlauch verbunden und in einer geschützten Position angeordnet sein.

Important notes

If there is a possibility that aggressive cutting lubricants and coolants penetrate through the sintered metal air filter into the cylinder's interior, a vent hose has to be connected and be placed in a protected position.

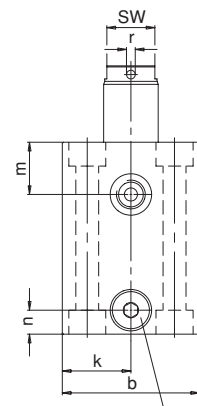
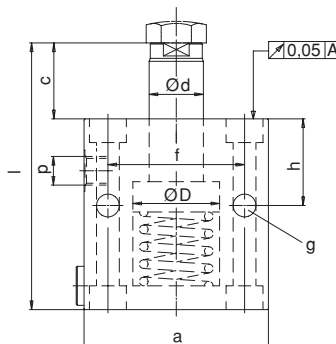
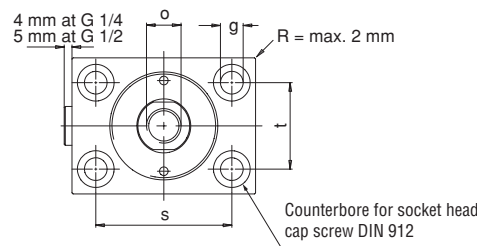

Die Zylinder müssen vorn getragen werden, um zu funktionieren. Druck über 250 bar

Cylinders must be supported at the front for operating pressures exceeding 250 bar

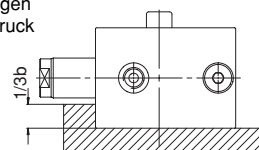

Entlüftung mit Stopfen mit Sintermetall-Luftfilter
Bleeding by plug with sintered metal air filter

Anwendung

Der pneumatische Schwenkspanner ist die beste Auswahl, wenn Werkstücke frei zugänglich eingelegt werden müssen und höhere Spannkraften in Spanneinrichtungen benötigt sind.

Funktion

Der Zylinder hat Zieh-Eigenschaft. Der Gesamthub entspricht dem Dreh- und Ziehhub.

Type

Der Zylinder übt Druck nach unten aus. Er bewegt sich im Uhrzeigersinn und umgekehrt. Standardwinkel ist 90°, optional 0°-45° und 60°.

Material

Der Grundkörper ist aus Aluminiumlegierung.



Application

When machining a workpiece by means of a machine tool, a pneumatic swing clamping cylinder will be your best choice if the placing and taking of the workpiece are not allowed to be interfered by the clammer and need a larger clamping force.

Function

This cylinder belongs to a pull cylinder of which the total stroke is equal to the sum of a swing stroke and a clamping stroke, and is usually used within the clamping stroke.

Type

This swing cylinder belongs to a double-acting type which is operated mainly in a downward pressing manner, including clockwise swing and counterclockwise swing; standard angle is 90°, and optional angles include 0°, 45°, 60°; clamping means includes single arm or double arms; the mounting manner includes threaded type and lower flange type for manifold mounting with O-ring seal.

Material

This material of the main body is aluminum alloy.



Bestellbeispiel / Ordering example

Referans Nr.	NAS Temel No. Base No.	T Type Flansch Flange T: verzahnt T: Threaded	D Arm Type D: Doppelarm D: Double Arm Leer : Einzelbewegung Blank: Single Arm	L – Drehrichtung Swivel Direction L: links L: Left R: rechts R: Right	40 Kolben / Piston Ø 25 32 40 50 63	x 90° – Winkel / Angle 0° 45° 60° 90° 180°
--------------	------------------------------	--	--	---	---	--

Schematische Übersicht theoretischer Spannkraften unter unterschiedlichem pneumatischen Druck

Schematic view showing a theoretical clamping force under different pneumatic pressure:

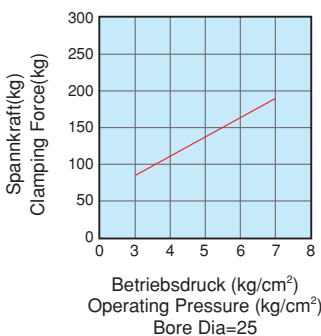
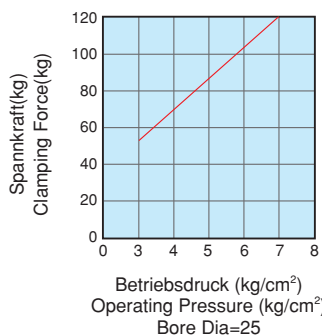
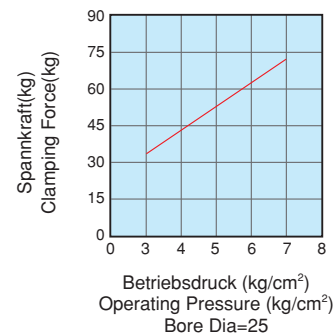
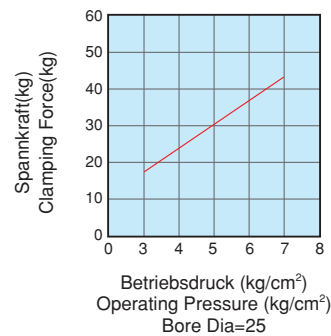
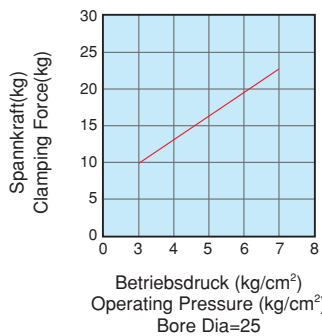

Referenz-Nr. Order No.	Spann-Type Mounting Type	Spannarm Clamping Arm	Max. Druck Max. Pressure	Normaldruck Normal Pres.	Bewegungs-Type Acting Type	Drehwinkel Swivel Angle	Drehhub Swivel Stroke (mm)	Spannhub Clamp Str. (mm)	Bohrdurchmesser Diameter Ø (mm)	Kolbenstange Piston Rod Ø	Spannkraft Force (25kg/cm ²)	A (mm) Lösen Unclamp	B (mm)	C (mm)	D (mm)	G (mm)	H (mm)	L1 Spannen / Clamp L2 Lösen / Unclamp	I (mm)	P (mm)	Q (mm)	R (mm)	S (mm)	M (mm)	F (mm)	Gewicht Weight (kg)
1058-NAS025	Bottom Flange	1-Arm / Single Arm	7 kg/cm ²	4-6 kg/cm ²	doppelseitige Bewegung / Double Acting	90° (0° 45°, 60°, 180°) ± 2°	12	14	25	14	16	95.5	65.5	23	□ 16	30	8	M5	M6	30	40	∅ 4.5	∅ 35	18	12.5	0.40
1058-NAS032							12	14	32	16	30	102.5	71	23	□ 19	50	9	1/8 PF	M8	44	54	∅ 6.5	∅ 50	22	17	0.70
1058-NAS040							12	15	40	16	50	106	75	26	□ 19	50	9	1/8 PF	M8	48	58	∅ 6.5	∅ 55	26	19.5	0.85
1058-NAS050							14	15	50	20	85	113	80	26	□ 25.4	70	10	1/8 PF	M10	55	68	∅ 8.5	∅ 65	30	24	1.30
1058-NAS063							14	15	63	20	140	119	86	30	□ 25.4	70	10	1/8 PF	M10	64	80	∅ 8.5	∅ 70	40	20	1.80

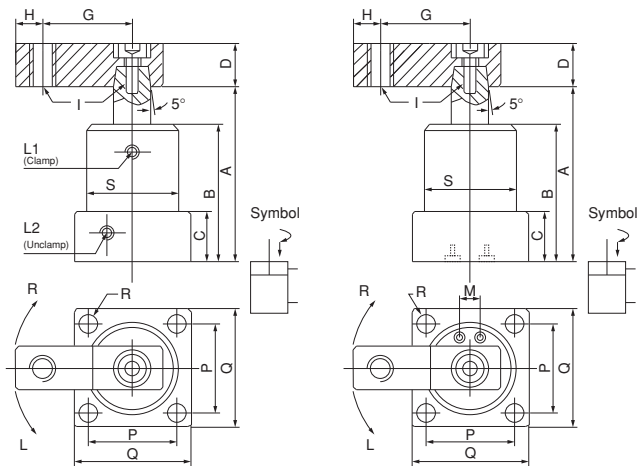

1058

NAS – Flanschversion, 1-Arm
Mit Rohr oder Verteiler

NAS – Flange Version, Single Arm
With Pipe or the Manifold

- Bei Bestellung bitte Bewegungs-Type und Drehwinkel angeben.
- Before buying please, movement indicate the type and rotation angle.



Referenz-Nr. Order No.	Spann-Type Mounting Type	Spannarm Clamping Arm	Max. Druck Max. Pressure	Normaldruck Normal Pres.	Bewegungs-Type Acting Type	Drehwinkel Swivel Angle	Drehhub Swivel Stroke (mm)	Spannhub Clamp Str. (mm)	Bohrdurchmesser Diameter Ø (mm)	Kolbenstange Piston Rod Ø	Spannkraft Force (25kg/cm ²)	A (mm) Lösen Unclamp	B (mm)	C (mm)	D (mm)	G (mm)	N (mm)	P (mm)	Q (mm)	R (mm)	S (mm)	M (mm)	F (mm)	Gewicht Weight (kg)	
1058-NASD032	Bottom Flange	2-Arm / Double Arm	7 kg/cm ²	4-6 kg/cm ²	doppelseitige Bewegung / Double Acting	90° (0° 45°, 60°, 180°) ± 2°	12	14	32	16	30	102.5	71	23	□ 19	100	1/8 PF	∅ 8	44	54	∅ 6.5	∅ 50	22	17	0.80
1058-NASD040							12	15	40	16	50	106	75	26	□ 19	100	1/8 PF	∅ 8	48	58	∅ 6.5	∅ 55	26	19.5	0.95
1058-NASD050							14	15	50	20	85	113	80	26	□ 22	120	1/8 PF	∅ 8	55	68	∅ 8.5	∅ 65	30	24	1.40
1058-NASD063							14	15	63	25	140	119	86	30	□ 22	120	1/8 PF	∅ 8	64	80	∅ 8.5	∅ 75	40	29	1.90

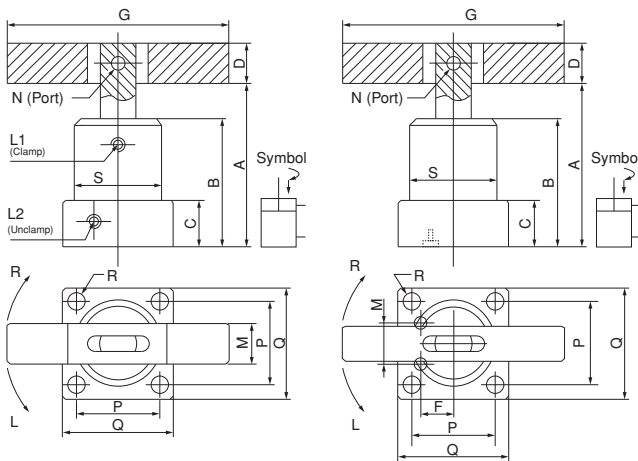

1058

NASD – Flanschversion, Doppelarm
Mit Rohr oder Verteiler

NASD – Flange Version, Double Arms
With Pipe or the Manifold

- Bei Bestellung bitte Bewegungs-Type und Drehwinkel angeben.
- Before buying please, movement indicate the type and rotation angle.



Referenz-Nr. Order No.	Spann-Type Mounting Type	Spannarm Clamping Arm	Max. Druck Max. Pressure	Normaldruck Normal Pres.	Bewegungs-Type Acting Type	Drehwinkel Swivel Angle	Drehhub Swivel Stroke (mm)	Spannhub Clamp. Str. (mm)	Bohrdurchmesser/ Bore Diameter Ø (mm)	Kolbenstange Piston Rod Ø	Spannkraft/Clamp Force (25kg/cm ²)	A (mm) Lösen Unclamp	B (mm)	C (mm)	D (mm)	G (mm)	H (mm)	I (mm)	L1 Spannen / Clamp L2 Lösen / Unclamp	N (mm)	S (mm)	T (mm) Kolbenmutter 2/St. T (mm) 2 pcs/set	Y (mm)	Gewicht Weight (kg)
1058-NATS025	verzahnter Körper / Threaded Body	1-Arm / Single Arm	7 kg/cm ²	4-6 kg/cm ²	doppelseitige Bewegung / Double-Acting	90° ± 2°	14	14	25	14	16	104	70	35	□ 16	50	6	10	M5	M6 x1	M40 x1.5	Ø 58	9	0.80
1058-NATS032							14	16	32	16	30	113	79	40	□ 19	60	9	13	1/8 PF	M8 x1.25	M50 x1.5	Ø 70	11	1.10
1058-NATS040							14	15	40	16	50	116	83	45	□ 19	70	9	13	1/8 PF	M8 x1.25	M55 x1.5	Ø 75	11	1.25
1058-NATS050							14	14	50	20	80	120	87	50	□ 25	80	10	13	1/8 PF	M12 x1.5	M65 x1.5	Ø 85	12	1.70
1058-NATS063							15	15	63	20	140	127	92	56	□ 25	90	10	13	1/8 PF	M12 x1.5	M80 x1.5	Ø 105	15	2.20

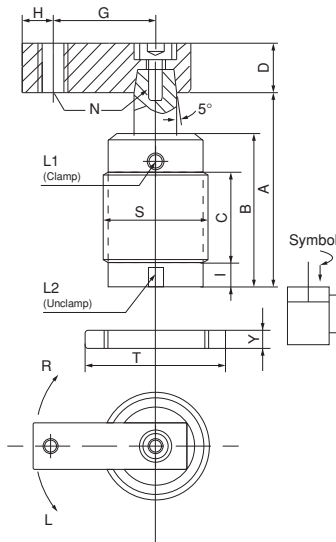

1058

NATS – Verzahnte Version, 1-Arm
Mit Rohr

NATS – Threaded Version, Single Arm
With Pipe

- Bei Bestellung bitte Bewegungs-Type und Drehwinkel angeben.
- Before buying please, movement indicate the type and rotation angle.



Pneumatischer Schwenkspanner

Pneumatic Swing Clamp

Referenz-Nr. Order No.	Spann-Type Mounting Type	Spannarm Clamping Arm	Max. Druck Max. Pressure	Normaldruck Normal Pres.	Bewegungs-Type Acting Type	Drehwinkel Swivel Angle	Drehhub Swivel Stroke (mm)	Spannhub Clamp. Str. (mm)	Bohrdurchmesser/ Bore Diameter Ø (mm)	Kolbenstange Piston Rod Ø	Spannkraft/Clamp Force (25kg/cm ²)	A (mm) Lösen Unclamp	B (mm)	C (mm)	D (mm)	G (mm)	I (mm)	L1 Spannen / Clamp L2 Lösen / Unclamp	N (mm)	S (mm)	T (mm) Kolbenmutter 2/St. T (mm) 2 pcs/set	Y (mm)	Gewicht Weight (kg)
1058-NATSD032	verzahnter Körper / Threaded Body	2-Arm / Double Arm	7 kg/cm ²	4-6 kg/cm ²	doppelseitige Bewegung / Double-Acting	90° (0° 45° 60° 180°) ± 2°	14	16	32	16	30	113	79	40	□ 19	100	13	1/8 PT	Ø 8	M50 x1.5	Ø 70	11	1.10
1058-NATSD040							14	15	40	16	50	116	83	45	□ 19	100	13	1/8 PT	Ø 8	M55 x1.5	Ø 75	11	1.30
1058-NATSD050							14	14	50	20	85	120	77	50	□ 22	120	13	1/8 PT	Ø 8	M65 x1.5	Ø 85	12	1.80

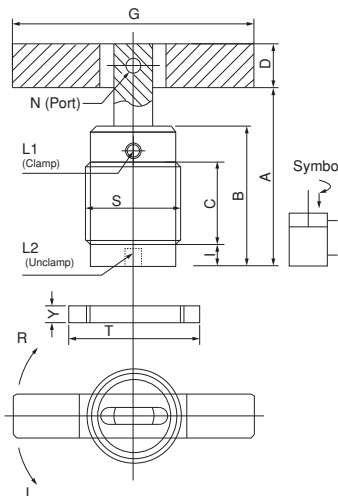

1058

NATSD – Verzahnte Version, Doppelarm
Mit Rohr

NATSD – Threaded Version, Double Arms
With Pipe

- Bei Bestellung bitte Bewegungs-Type und Drehwinkel angeben.
- Before buying please, movement indicate the type and rotation angle.



Referenz-Nr. Order No.	Betriebsdruck Operating Pressure	Arbeitstemperatur Operating Temperature	Spann-Typ Mounting Type	Hub Stroke (mm)	Bohrdurchmesser Diameter Ø (mm)	Kolbenstange Piston Rod Ø (mm)	Spannkraft Clamp. Force (7kg/cm ²)	A	B	C	D	E	F	G	H	I	J	K	L	M	O	N	P	Q	R	R1	S	L1 Spannen / Clamp	L2 Lösen / Uncclamp	Gewicht Weight (kg)
1058-PLCU25	4-10 kgf/cm ²	-10° ~ +80°	Kopffläsch & Eijnschraubzylinder Upper Flange & Threaded Body	22	Ø 25	Ø 14	27	128.5	86.5	25	61.5	50	17	16	M40 x1.5	60	50	37	18	23	23	7	35	25	5.5	9	M6 x1	M5 x0.8	0.60	
1058-PLCU32				28	Ø 32	Ø 16	40	149.5	97.5	25	72.5	57	20	18	M50 x1.5	70	60	45	22	30	23	8	40	30	6.5	11	M8 x1.25	G 1/8	1.00	
1058-PLCU40				30	Ø 40	Ø 16	66	157.5	97.5	25	72.5	60	25	20	M55 x1.5	75	65	50	24	32	26	10	42.5	32.5	6.5	11	M8 x1.25	G 1/8	1.20	
1058-PLCU50				30	Ø 50	Ø 20	105	174	104	25	79	65	30	22	M65 x1.5	88	75	58	27.5	36	32	14	50.5	37.5	8.5	14	M12 x1.75	G 1/8	2.00	
1058-PLCU63				30	Ø 63	Ø 20	166	179	105	25	80	69	30	22	M80 x1.5	108	90	70	32	42	35	14	63	45	8.5	14	M12 x1.75	G 1/8	2.70	

1058



Mit Rohr / With Pipe

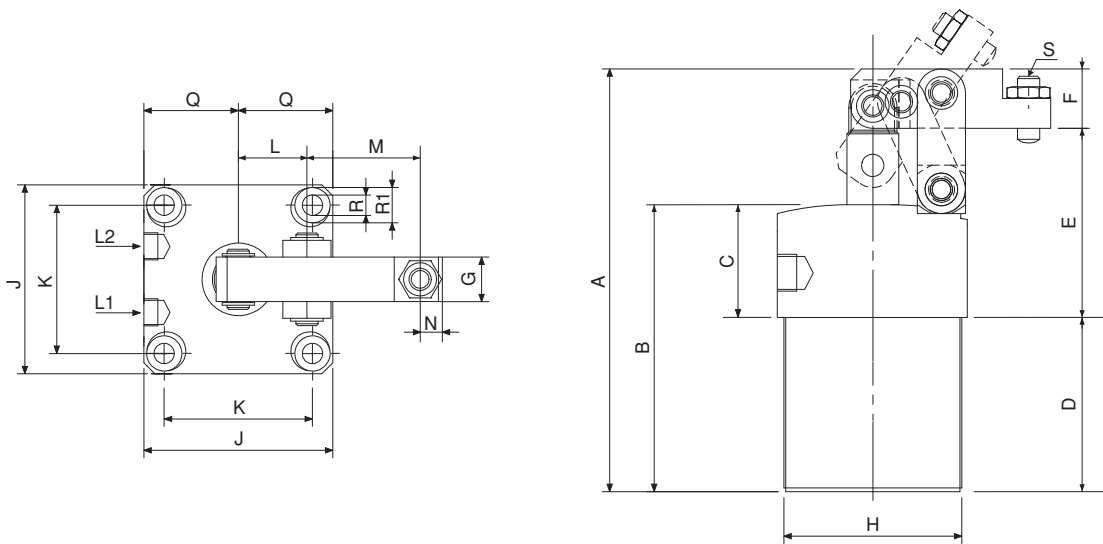

Anwendung Hydraulischer Komponenten

Hydraulic Component Application





ER-EL[®] ZERO CLAMP

Null-Punkt-Spannsystem
Zero Point Clamping Systems



Ø90
1250 kgf



Ø120
2500 kgf



Ø138
4000 kgf



Ø190
6000 kgf



ER-EL[®] ZERO CLAMP



der Wiederholtoleranz
Höhepunkt

0,005 Wiederholtoleranz
0,005 repeating tolerance



Nr. 2475

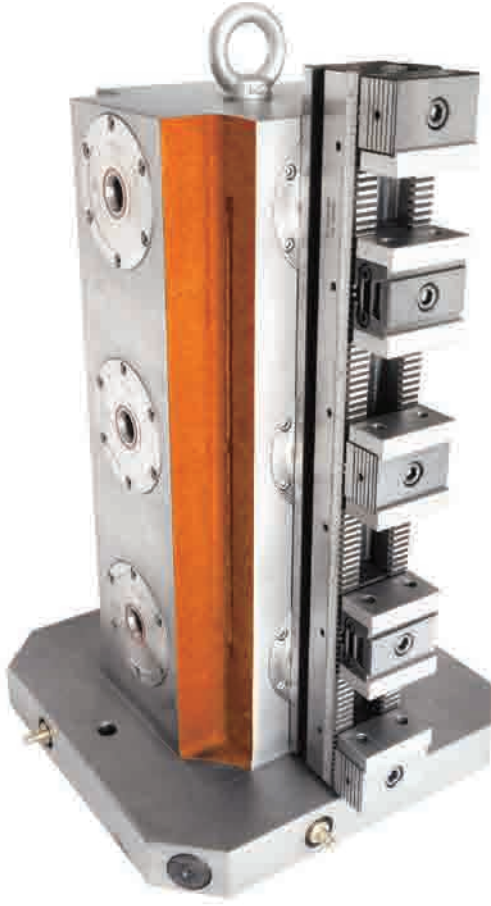

Nr. 2480



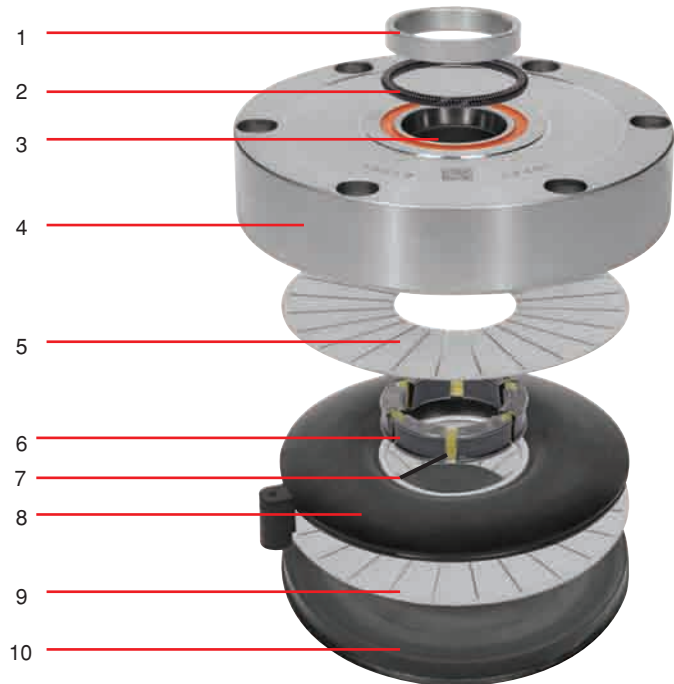

Beschreibung / Description

- 1- Gehärteter Stahlring / Hardened steel cone
- 2- Radiale Feder / Radial spring
- 3- Gummi NBR / NBR rubber
- 4- Spannfutter / Chuck housing
- 5- Spannplatte / Clamping sheets
- 6- Verriegelung / Locking unit
- 7- Distanzscheibe (Elastomer) / Spacer (Elastomer)
- 8- Druckluftschlauch / Air hose
- 9- Spannplatten / Clamping sheets
- 10- Gehäusedeckel / Housing cover

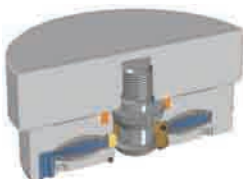

Palette wird einfach auf den geöffneten ZeroClamp Spanntopf aufgesetzt. Dabei besteht keine Gefahr der Verkantung

The pallet is placed on the opened ZeroClamp chuck.



Die Federelemente halten durch den Luftdruck (6 bar) im Luftschlauch die Verriegelungseinheit (Klemmkeile) offen

The spring elements keep the locking unit (clamping wedges) open with the help of the air pressure inside the air hose.



Durch das Entlüften des Luftschlauchs positioniert der Spanntopf das Werkstück an die Plananlage mit einer Haltekraft von 25 kN (mit 2,5 µm Wiederholgenauigkeit)

Venting the air hose results in the positioning and clamping of the clamp bolt in the chuck.

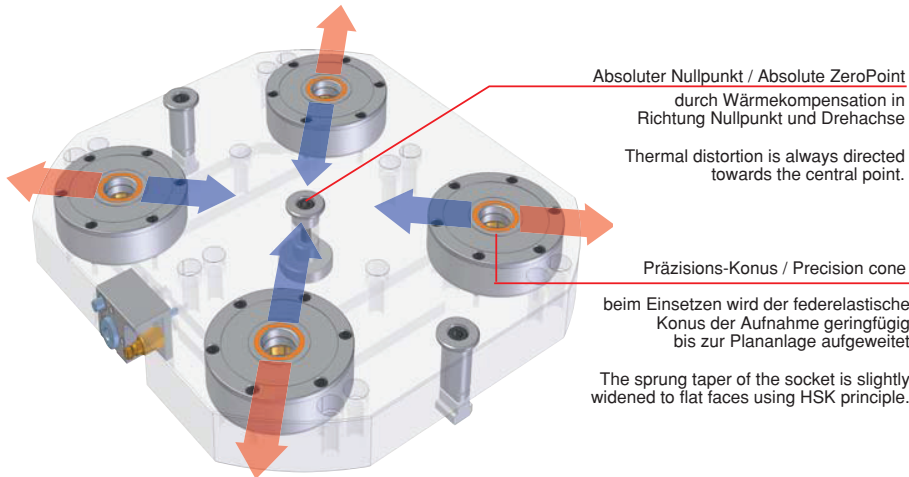

- Der absolute Nullpunkt: Kompensation der Wärmeausdehnungen immer zur Mittelachse
 - Ausgleich von Stichmaßfehlern bis zu max. $\pm 0,1$ mm über 2 Spanntöpfe möglich
 - Spielfreie Spezial-Spannkonusen für vibrationsarmen Lauf
 - Kein Einsatz von Schwert- und Wanderbolzen erforderlich
- Absolute ZeroPoint: Compensation for thermal change is always towards centre axis
 - Clamping stud location errors of up to ± 0.1 mm can be compensated for
 - Precision clamping cones are free from play for low-vibration operation
 - Special sword studs or loose/sliding studs are not required

HSK-Prinzip

Klassische Systeme zentrieren entweder über eine zylindrische Passung oder über einen starren Kegel. Bei einer zylindrischen Passung ist immer eine Spielpassung (z. B. 25 H5 Aufnahme / 25 h5 Bolzen) erforderlich. Eine solche Kombination kann bis zu 18 µm Spiel aufweisen. Bei konischen Passungen muss der Konus extrem genau abgestimmt werden. Wenn nicht, tritt sofort ein Überstand der Palette auf (bei zu großen Bolzen), oder es kommt zu einer Spielpassung wie bei zylindrischen Systemen.

Das ZeroClamp Nullpunktspannsystem funktioniert vergleichbar dem HSK-Werkzeugkegel. Beim HSK-Werkzeugkegel wird beim Einziehen des Kegels in die Aufnahme der dünnwandige Kegel solange verformt bis die Planseite des Kegels an der Aufnahme anliegt.

Im Prinzip arbeitet das Nullpunktspannsystem ähnlich: Der Konusring der Aufnahme wird beim Einziehen minimal aufgeweitet. Wenn die Palette oder das Werkstück an der Plananlage anliegen ist ein absolut spielfreier Sitz gewährleistet.

HSK Principle

Traditional systems use either a cylindrical seat or a rigid cone for centring. A cylindrical seat always requires some amount of play (i.e. 25 H5 holder / 25 h5 bolt). Play in such a combination may be as much as 0.018. With a conical fit the cone must be shaped precisely. Otherwise the pallet will protrude if the bolts are too large, or else the play will be the same as in a cylindrical system.

The function of the Zero Clamp zero point clamping system resembles that of a hollow cone HSK shank. In this system the thin-walled cone is deformed as it is drawn in until its surface exactly matches the contours of the seat.

Zero Clamp zero point clamping system works the same way, using face and taper contact. While the cone is being drawn in, the seat ring will be widened minimally. Within the pallet or the workpiece in contact with the plane seat and so any play is eliminated.

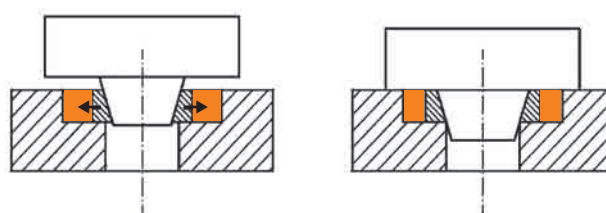

ZeroClamp ZeroClamp Unique Features	Marktübliche Systeme Competitor Systems
<p>Patentiertes Design, einfacher Aufbau. Durch extrem wenige und einfache Bauteile wird eine hohe Zuverlässigkeit erreicht. Selbst Späne können dem Funktionsprinzip nichts anhaben.</p> <p>Patent-registered design with a simple layout. Just a few simple components provide an extremely reliable design. Even swarf will not affect the function of the clamping unit.</p>	<p>Komplexe Mechanik mit Kugellagern, Kolben, Schiebern und anderen Bauteilen. Bei Verschmutzung durch Späne besteht die Gefahr der Blockade oder fehlerhaften Funktion.</p> <p>Complex mechanics using ball cages, pistons, valves, etc. When contaminated with swarf there is a risk of blockage and/or malfunction.</p>
<p>Höchste Genauigkeit durch HSK-Prinzip. Beim Einzug des Spannbolzens wird der Konusring des Spanntopfes im elastischen Bereich leicht aufgeweitet. Dadurch ergibt sich ein absolut spielfreier hochgenauer Sitz, und eine Wiederholgenauigkeit von 0.005.</p> <p>High precision due to the HSK principle When retracting the clamping bolt, the elastic part of the taper ring of the chuck will be slightly expanded providing a perfect and extremely accurate fit with a repeatability of less than 0.005</p>	<p>Üblicherweise ist eine Fügepassung erforderlich (z. B. 32 mm h5/H5 für Bolzen und Aufnahme). Bei dieser genannten Kombination ist ein minimales Spiel von 0 µm und ein maximales von 0.022 möglich. Wie sollen dabei serienmäßige Wiederholgenauigkeiten bis zu 0.005 erreichbar werden?</p> <p>Normally a light sliding fit is required (e.g. 32 mm h5/H5 for bolts and mountings). In this particular case the minimum backlash is 0 µm whereas the maximum is 0.022 So the claimed repeatability (0.005) must be difficult to achieve.</p>
<p>Thermosymmetrie Ausgleich bei thermischen Einflüssen oder Stichmaßfehlern durch das HSK-Prinzip. Die Konusringe gleichen Fehler immer zur Mitte der Spannstellen aus. (Auf einem Rundtisch bleibt beispielsweise die Palettenmitte immer in Achsmitte).</p> <p>Thermal stability Thermal effects and/or micro deviations are compensated for by the hollow shank taper (HSK) principle. The taper rings always compensate for the errors to the centre of the clamping position. (On a rotary table the centre of a pallet always remains on the centre line of the machine).</p>	<p>Starres System mit 3 verschiedenen Bolzentypen. Thermische Einflüsse oder Stichmaßfehler führen zu einer unsymmetrischen Verschiebung ausgehend vom Nullbolzen. (Auf einem Rundtisch wird die Palettenmitte aus der Achsmitte gedrückt)</p> <p>Fixed system with three different bolt designs. Thermal effects and/or micro deviations will cause asymmetrical off sets originating from the zero bolt. (On a rotary table, the centre of a pallet will be pushed away from the centre line of the machine).</p>
<p>Nur ein Spannbolzentyp erforderlich. Logistisch einfach handhabbar da in die vorhandene Bolzenbohrung nur ein Bolzentyp eingeschraubt werden muss.</p> <p>Only one type of clamping bolt required. Far simpler to manage as only one type of bolt needs to be screwed into the pin bore.</p>	<p>Im Allgemeinen drei verschiedene Bolzentypen (Nullbolzen, Wander- oder Schwertbolzen, Freibolzen). Logistisch kompliziert. Es muss für jede Vorrichtung dokumentiert werden, welcher Bolzen an welcher Stelle in welcher Winkellage zu montieren ist. Hohe Fehlergefahr!</p> <p>Generally three different types of bolts required (zero bolt, floating or sword bolt, free bolt). Very complicated, each fixture needs to be documented with set up instructions, showing which bolt has to be mounted where and in which angular position. So there is a high risk of errors.</p>
<p>Keine Selbsthemmung Im Crashfall kann die Vorrichtung oder das Spannmittel nachgeben und damit möglicherweise die Maschinenspindel gerettet werden. Im Falle einer Beschädigung der Energiezufuhr ist es zum Beispiel über Abdruckschrauben möglich die Vorrichtung zu entfernen.</p> <p>No self-locking. In case of a crash, the fixture or the clamping device can give way, possibly saving the machine spindle. In the case of damage to the airways for energy supply, forcing screws will allow the removal of the fixture.</p>	<p>Bei selbsthemmenden Systemen wird im Falle eines Crashes der größtmögliche Schaden auftreten. Bei Beschädigung der Energiezufuhr muss die Vorrichtung in den meisten Fällen zerstört werden um die Palette zu entfernen.</p> <p>In case of a crash self-locking systems will cause the worst possible damage. In the case of a power loss, in most cases the fixture will have to be completely destroyed in order to be able to remove the pallet.</p>
<p>Kein Verkanten Durch konstruktive Maßnahmen kein Verkanten der Bolzen. Unkompliziertes Fügen und Entnehmen auch bei Schräglage oder großem Mittenversatz.</p> <p>No tilting Layout and design will prevent any tilting of the clamping bolts. Easy joining and removal even in inclined positions or with an unbalanced load with a large off set of the centre of gravity.</p>	<p>Teilweise muss ganz stellungsgenau und parallel gefügt oder entnommen werden, da zylindrische oder konische Spannbolzen mit minimaler Verjüngung verwendet werden. Speziell das Entnehmen von stark unsymmetrischen schweren Bauteilen ist sehr problematisch.</p> <p>Joining and removal must be carried out in precisely defined and parallel positions as the cylindrical or tapered clamping bolts used have a minimal taper. The removal of heavy asymmetric components will always cause problems.</p>
<p>Pneumatisches System mit geringer Bauhöhe Durch das patentierte Design des Federspeichers sind sehr hohe Haltekräfte gewährleistet. Bereits gängiger Werkstattdruck löst die Spannvorrichtung.</p> <p>Pneumatic system with low installation height Clamping via spring assembly, unclamping by means of compressed air. Patented design for very high clamping force even with standard air-pressures.</p>	<p>Hydraulische Systeme mit den systembedingten Nachteilen: Pumpe - Zuleitung - Kollision – Leckage - Entlüften etc. Bauhöhen der pneumatischen Systeme teils deutlich größer.</p> <p>Hydraulic systems have disadvantages determined by the system: pump, duct, collision, leakage, bleeding, etc. Also, installation costs tend to be more expensive compared to pneumatic systems.</p>

Referenz-Nr. Order No.	d	h	d1		Spannkraft clamping force Kgf	 (g)
				Nm		
1060-090	90	22	M4	5	1250	730
1060-120	120	28	M6	14	2500	1840
1060-138	138	33	M8	35	4000	2860
1060-190	190	38	M8	35	6000	5460

1060

- Min. Bar 5.5
- Max. Bar 8

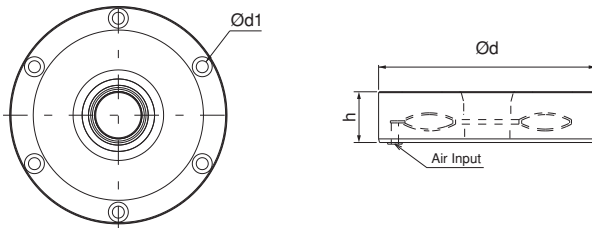

Spannbolzen

Pull Stud

Referenz-Nr. Order No.	m	L	d	sw	Nm	 (g)
1065-12016	M16	22	18 k6	8	170	97
1065-13816	M16	30	25 k6	8	170	235
1065-19024	M24	36	30 k6	10	400	460

1065

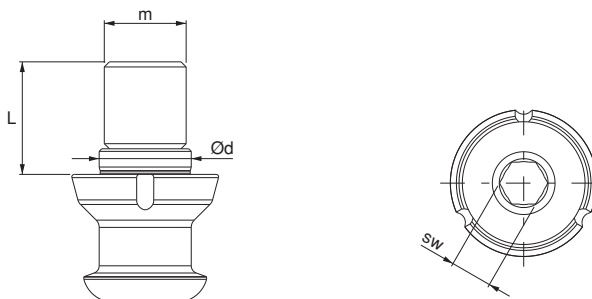

Verschlussbolzen

Body Chip Protector

Referenz-Nr. Order No.	Zero	 (g)
1067-090	90	29
1067-120	120	85
1067-138	138	202
1067-190	190	398

1067



Spannelemente

Clamping Equipment



Kraftspanner Verschiebbar

Combined Sliding Clamp



Berechnung für die Anwendung

Calculation For The Application

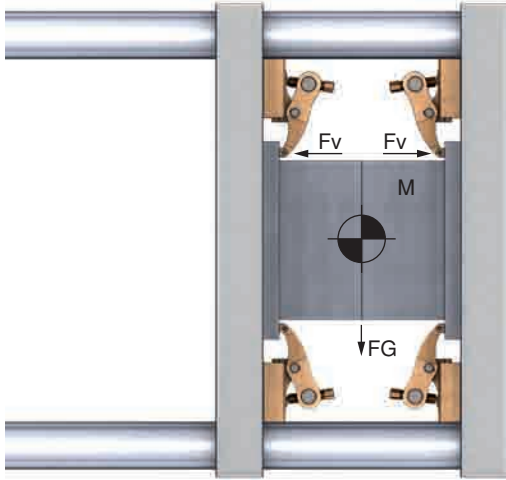

Anwendungsbeispiel für Spritzgusswerkzeuge Power Clamp For Injection Moulding

Rechenformel / Formula Calculator

$$\frac{M \times FG}{1000} = \text{kN} \quad \frac{2500 \times 9.81}{1000} = 24.52 \text{ kN}$$

$$\frac{\text{kN}}{\mu} = \text{Ergebnis / Result} \quad \frac{24.52}{0.14} = 175.14 \text{ kN}$$

$$\frac{\text{Ergebnis}}{F_v} = \text{Spann-Anzahl} \quad \frac{175.14 \text{ kN}}{25 \text{ kN}} = 7 \text{ Spannen / Clamp}$$

8 Stück verwenden
8 pcs Use

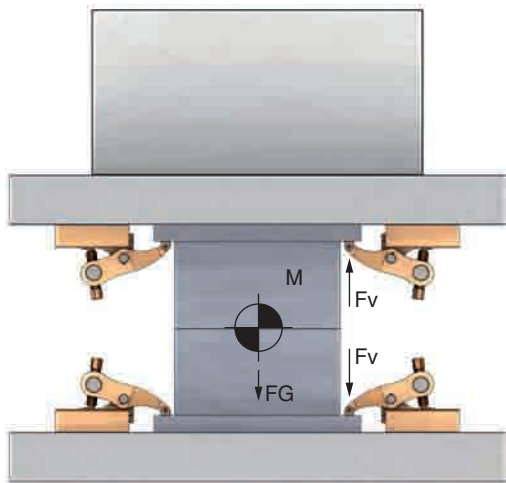

Anwendungsbeispiel für Presswerkzeuge Power Clamp For Press Moulding

Rechenformel / Formula Calculator

$$\frac{M \times FG}{1000} = \text{kN} \quad \frac{5000 \times 9.81}{1000} = 49.050 \text{ kN}$$

$$\frac{\text{kN}}{\mu} = \text{Ergebnis / Result} \quad \frac{49.05}{0.14} = 350.35 \text{ kN}$$

(%60 Oberes Werkzeug= 210.21)
(% 40 Unteres Werkzeug= 140.14)

$$\frac{\text{Ergebnis}}{F_v} = \text{Spann-Anzahl} \quad \frac{210.21 \text{ kN}}{25 \text{ kN}} = 8 \text{ Spann-Anzahl}$$

8 Number of Clamp

$$\frac{\text{Ergebnis}}{F_v} = \text{Spann-Anzahl} \quad \frac{140.14 \text{ kN}}{25 \text{ kN}} = 5.6 \text{ Spannen / Clamp}$$

6 Stück verwenden
6 pcs Use

Kraftdiagramm / Force Diagram

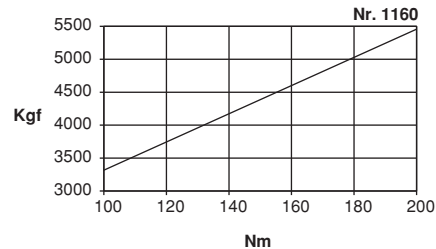
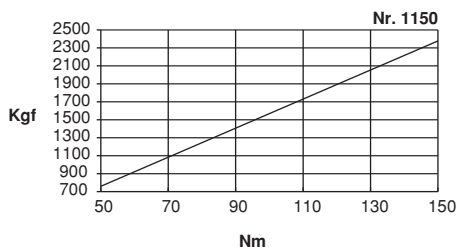
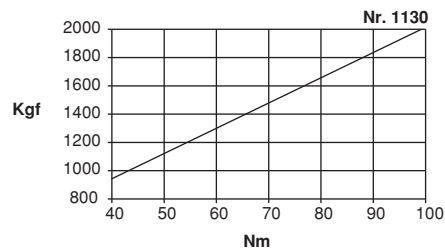
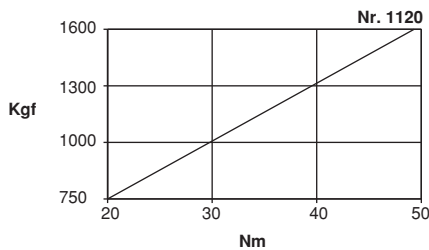

Referenz-Nr. Order No.		m	h		s	s1	e1	d	sw 	L	e	b	c	Spannkraft Clamping Force Kgf	 (g)
			min	max											
1120-014 T	14	M12	0	50	12-66	25	100	M14	8	104	35.5	38	13	1600	1700
1120-016 T	16	M12	0	50	12-66	25	100	M14	8	104	35.5	38	13	1600	1700
1120-018 T	18	M12	0	50	12-66	25	100	M14	8	104	35.5	38	13	1600	1700
1130-014 T	14	M12	0	60	15-83	30	113	M18	10	130	39	48	17.5	2000	3040
1130-016 T	16	M12	0	60	15-83	30	113	M18	10	130	39	48	17.5	2000	3055
1130-018 T	18	M12	0	60	15-83	30	113	M18	10	130	39	48	17.5	2000	3085
1130-020 T	20	M12	0	60	15-83	30	113	M18	10	130	39	48	17.5	2000	3135
1130-022 T	22	M12	0	60	15-83	30	113	M18	10	130	39	48	17.5	2000	3150

1120-1130

• **1120** (a) 14-18 in T-Nut wird Inbusschraube M12 DIN 508 mit T-Nutmutter verwendet. Spannhöhe 0-50 mm, Spannweite 54 mm, Spannkraft 1600 kg.

• **1130** (a) 14-22 in T-Nut wird Inbusschraube M12 DIN 508 mit T-Nutmutter verwendet. Spannhöhe 0-60 mm, Spannweite 68 mm, Spannkraft 2000 kg.

1120-1130

• **1120** (a) 14-18 is used in T-Slot and M12 imbus bolt is used with DIN 508 T-Nut. Height clamping gap of the piece is 0-50mm, back-and- forth movement distance is 54mm. Clamping force is 1600 kgf.

• **1130** (a) 14-22 is used in T-Slot and M12 imbus bolt is used with DIN 508 T-Nut. Height clamping gap of the piece is 0-60mm, back-and- forth movement distance is 68mm. Clamping force is 2000 kgf.

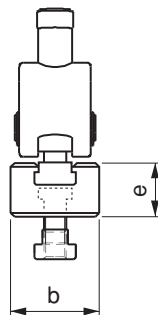
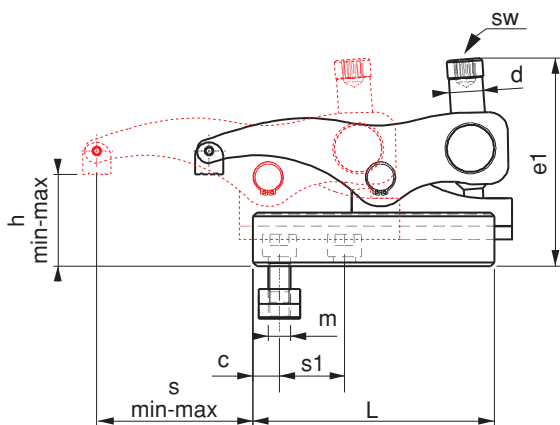
ANWENDUNG;

- 1- Zwischenelement an Werkstück befestigen
- 2- Grundkörper auf Zwischenelement verschieben
- 3- Werkstück mit Inbusschraube befestigen
- 4- Werkstück ist zum Bearbeiten bereit

APPLICATION;

- 1- Slide cradle is brought to suitable form with the work piece and then it is fixed
- 2- Upper body is driven to the slide and it is brought to desired position
- 3- Work piece is fixed with the imbus bolt of the clamp
- 4- Then the work piece becomes ready to be machined.

Verwendung

Injektionsmaschinen, Pressen, Fräsmaschinen, Bohrzentren, verschiedene Industriemaschinen

Area of Use

Injection Machines, Presses, Milling Machines, Drilling Machines and various Industrial Machines

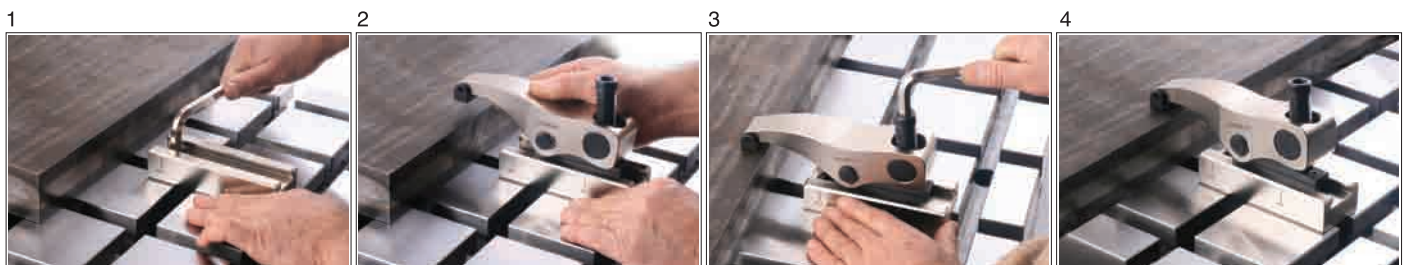

Referenz-Nr. Order No.		m	h		s	s1	e1	d	sw	L	e	b	c	Spannkraft Clamping Force Kgf	 (g)	
			min	max												
1150-118 T	18	M16	0	65	18-96	35	125	M20	12	140	43	55	19.5	2500	4410	
1150-120 T	20	M16	0	65	18-96	35	125	M20	12	140	43	55	19.5	2500	4460	
1150-122 T	22	M16	0	65	18-96	35	125	M20	12	140	43	55	19.5	2500	4515	
1150-124 T	24	M16	0	65	18-96	35	125	M20	12	140	43	55	19.5	2500	4620	
1150-128 T	28	M16	0	65	18-96	35	125	M20	12	140	43	55	19.5	2500	4725	
1160-222 T	22	M20	20	80	17-92	41.5	175	M24	12	24	178	55	74	24	5500	9030
1160-224 T	24	M20	20	80	17-92	41.5	175	M24	12	24	178	55	74	24	5500	9120
1160-228 T	28	M24	20	80	17-92	41.5	175	M24	12	24	178	55	74	24	5500	9180
1160-236 T	36	M24	20	80	17-92	41.5	175	M24	12	24	178	55	74	24	5500	9600

1150-1160

• **1150** (a) 18-28 in T-Nut wird Inbusschraube M16 DIN 508 mit T-Nutmutter verwendet. Spannhöhe 0-65 mm, Spannweite 78 mm, Spannkraft 2500 kg.

• **1160** (a) 22-36 in T-Nut wird Inbusschraube M20-M24 DIN 508 mit T-Nutmutter verwendet. Spannhöhe 20-80 mm, Spannweite 73 mm, Spannkraft 5500 kg.

1150-1160

• **Nr. 1150** (a) 18-28 is used in T-Slot and M16 imbus bolt is used with DIN 508 T-Nut. Height clamping gap of the piece is 0-65mm, back-and- forth movement distance is 78mm. Clamping force is 2500 kgf.

• **Nr. 1160** (a) 22-36 is used in T-Slot and M20-M24 imbus bolt is used with DIN 508 T-Nut. Height clamping gap of the piece is 20-80mm, back-and- forth movement distance is 73mm. Clamping force is 5500 kgf.

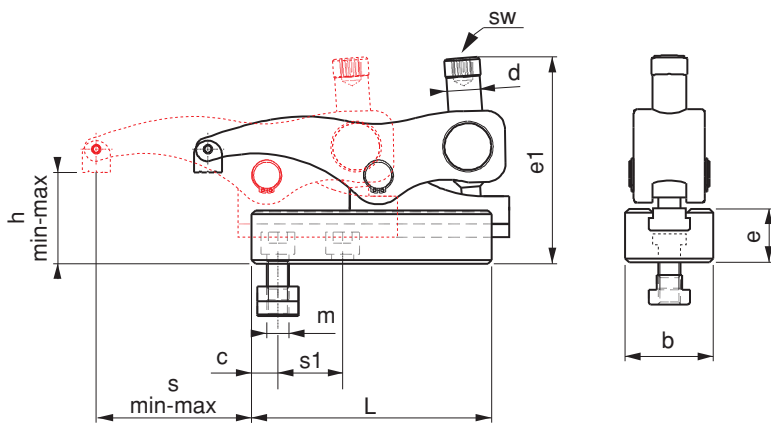
ANWENDUNG;

- 1- Zwischenelement an Werkstück befestigen
- 2- Grundkörper auf Zwischenelement verschieben
- 3- Werkstück mit Inbusschraube befestigen
- 4- Werkstück ist zum Bearbeiten bereit

APPLICATION;

- 1- Slide cradle is brought to suitable form with the work piece and then it is fixed
- 2- Upper body is driven to the slide and it is brought to desired position
- 3- Work piece is fixed with the imbus bolt of the clamp
- 4- Then the work piece becomes ready to be machined.

Verwendung

Injektionsmaschinen, Pressen, Fräsmaschinen, Bohrzentren, verschiedene Industriemaschinen

Area of Use

Injection Machines, Presses, Milling Machines, Drilling Machines and various Industrial Machines

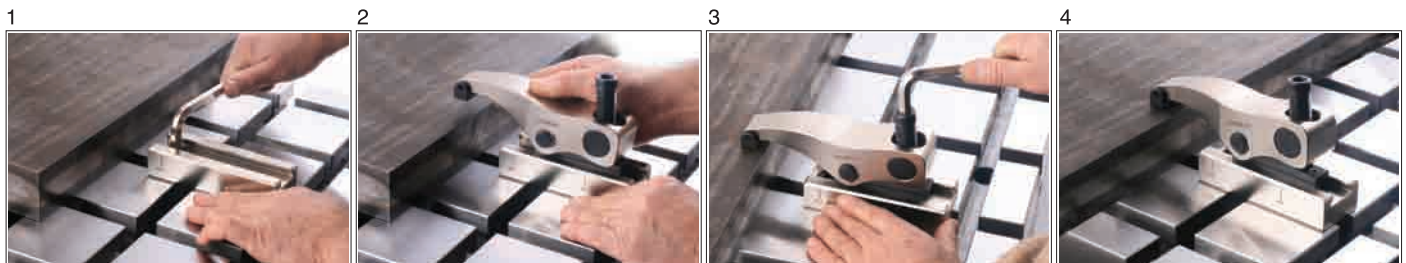

Referenz-Nr. Order No.		m	h		s	e1	e2	d		L	b	e3	c	
			min	max										
1120-014 DT	14	M12	36	86	12-66	136	71.5	M14	8	104	38	38	13	2540
1120-016 DT	16	M12	36	86	12-66	136	71.5	M14	8	104	38	38	13	2540
1120-018 DT	18	M12	36	86	12-66	136	71.5	M14	8	104	38	38	13	2540
1130-014 DT	14	M12	45	105	15-83	158	83	M18	10	130	48	45	17.5	4750
1130-016 DT	16	M12	45	105	15-83	158	83	M18	10	130	48	45	17.5	4775
1130-018 DT	18	M12	45	105	15-83	158	83	M18	10	130	48	45	17.5	4805
1130-020 DT	20	M12	45	105	15-83	158	83	M18	10	130	48	45	17.5	4855
1130-022 DT	22	M12	45	105	15-83	158	83	M18	10	130	48	45	17.5	4905

1120

- Verwendung mit Inbusschraube M12 DIN 508 und T-Nutmutter
- Spannhöhe 36-86 mm
- Spannkraft 1600 kg.

1120

- M12 imbus bolt is used with DIN 508 "T" clamp.
- Height clamping gap of the piece is 36-86mm
- Clamping Force is 1600kgf

1130

- Verwendung mit Inbusschraube M12 DIN 508 und T-Nutmutter
- Spannhöhe 45-105 mm
- Spannkraft 2000 kg.

1130

- M12 imbus bolt is used with DIN 508 "T" clamp.
- Height clamping gap of the piece is 45-105mm
- Clamping Force is 2000kgf

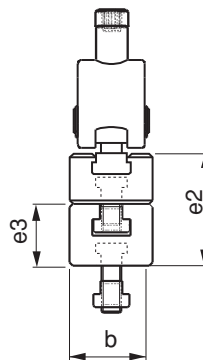
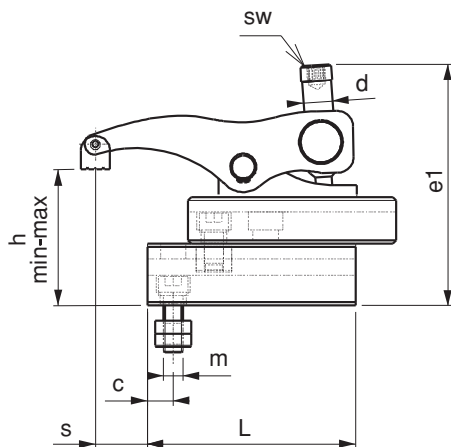
ANWENDUNG;

- 1- Zwischenstück an Werkstück befestigen
- 2- Höhen-Anpassung durch weitere Zwischenstücke
- 3- Grundkörper auf Zwischenstück schieben, Inbusschraube auf T-Nut positionieren
- 4- Werkstück mit Inbusschraube befestigen

APPLICATION

- 1- Bottom support is brought to suitable form with the work piece and then it is fixed.
- 2- Desired distance is reached by increasing K.K.S.P supports
- 3- K.K.S.P. is applied in "T" slot with imbus bolt against "T" clamp
- 4- Work piece is fixed with the imbus bolt of the clamp

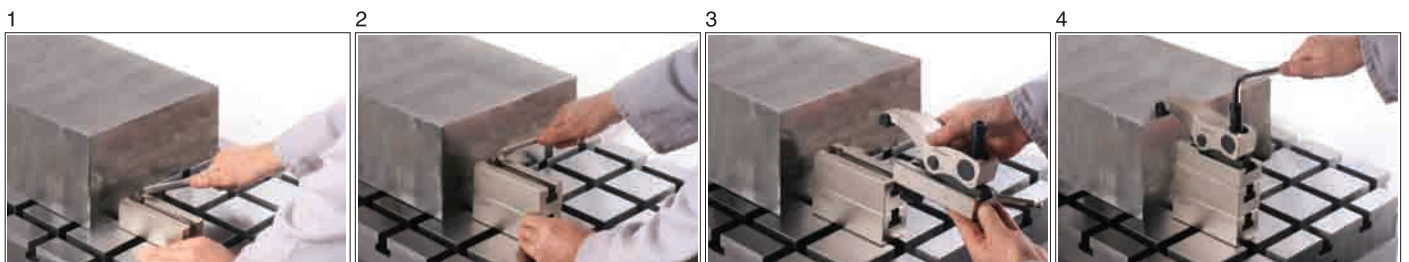

Referenz-Nr. Order No.	a	m	h		s	e1	e2	d	sw		L	b	e3	c	
			min	max											
1150-118 DT	18	M16	48	113	18-96	173	90	M20	12		140	55	48	19.5	6625
1150-120 DT	20	M16	48	113	18-96	173	90	M20	12		140	55	48	19.5	6690
1150-122 DT	22	M16	48	113	18-96	173	90	M20	12		140	55	48	19.5	6750
1150-124 DT	24	M16	48	113	18-96	173	90	M20	12		140	55	48	19.5	6840
1150-128 DT	28	M16	48	113	18-96	173	90	M20	12		140	55	48	19.5	6960
1160-222 DT	22	M20	79	139	17-92	235	114	M24	12	24	178	74	59	24	13330
1160-224 DT	24	M20	79	139	17-92	235	114	M24	12	24	178	74	59	24	13465
1160-228 DT	28	M24	79	139	17-92	235	114	M24	12	24	178	74	59	24	13580
1160-236 DT	36	M24	79	139	17-92	235	114	M24	12	24	178	74	59	24	13890

1150

- Verwendung mit Inbusschraube M16 DIN 508 und T-Nutmutter
- Spannhöhe 48-113 mm
- Spannkraft 2500 kg.

1150

- M16 imbus bolt is used with DIN 508 "T" clamp.
- Height clamping gap of the piece is 48-113mm
- Clamping Force is 2500kgf

1160

- Verwendung mit Inbusschraube M20-M24 DIN 508 und T-Nutmutter
- Spannhöhe 79-139 mm
- Spannkraft 5500 kg.

1160

- M20-M24 imbus bolt is used with DIN 508 "T" clamp.
- Height clamping gap of the piece is 79-139mm
- Clamping Force is 5500kgf

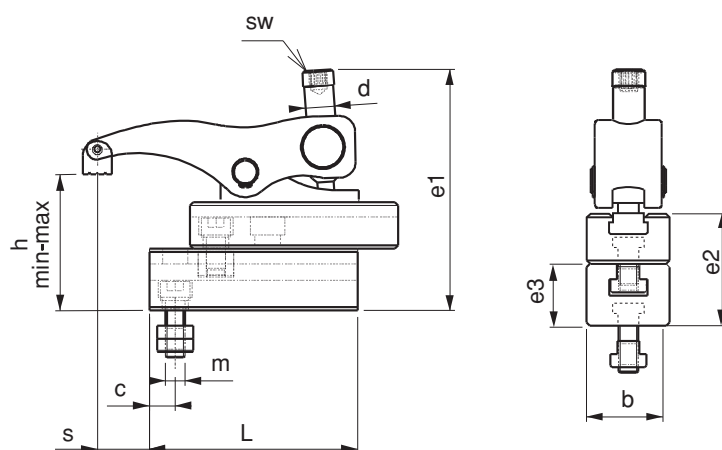

ANWENDUNG;

- 1- Zwischenstück an Werkstück befestigen
- 2- Höhen-Anpassung durch weitere Zwischenstücke
- 3- Grundkörper auf Zwischenstück schieben, Inbusschraube auf T-Nut positionieren
- 4- Werkstück mit Inbusschraube befestigen

APPLICATION

- 1- Bottom support is brought to suitable form with the work piece and then it is fixed.
- 2- Desired distance is reached by increasing K.K.S.P supports
- 3- K.K.S.P is applied in "T" slot with imbus bolt against "T" clamp
- 4- Work piece is fixed with the imbus bolt of the clamp

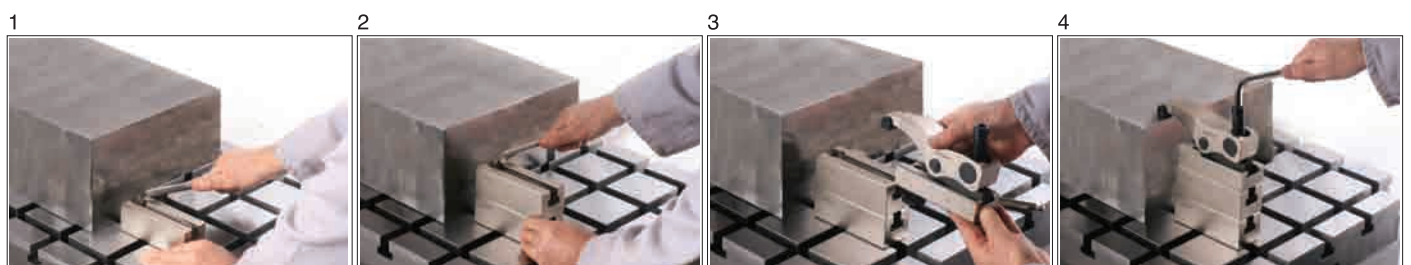

Referenz-Nr. Order No.		h min max	s	s1	e1	d	sw 	L	e	b	c	k	Spannkraft Clamping Force Kgf	
1120-010 M	M10	0 50	12-66	25	100	M14	8	104	35.5	38	13	20	1600	1700
1120-012 M	M12	0 50	12-66	25	100	M14	8	104	35.5	38	13	20	1600	1700
1130-012 M	M12	0 60	15-83	30	113	M18	10	130	39	48	17.5	22	2000	3000
1130-016 M	M16	0 60	15-83	30	113	M18	10	130	39	48	17.5	26	2000	3030

1120

- Für Gewinde M12-M16 Inbusschrauben 1120-310 / 1120-312 verwenden
- Spannhöhe 0-50 mm
- Spannkraft 1600 kg

1120

- In the outer holes M12-M16 are used with the Reference Nr. imbus bolt (1120-310)-(1120-312)
- Height clamping gap of the piece is 0-50mm
- Clamping Force is 1600 kgf.

1130

- Für Gewinde M12-M16 Inbusschrauben 1130-412 / 1130-416 verwenden
- Spannhöhe 0-60 mm
- Spannkraft 2000 kg

1130

- In the outer holes M12-M16 are used with the Reference Nr. imbus bolt (1130-412)-(1130-416)
- Height clamping gap of the piece is 0-60mm
- Clamping Force is 2000 kgf.

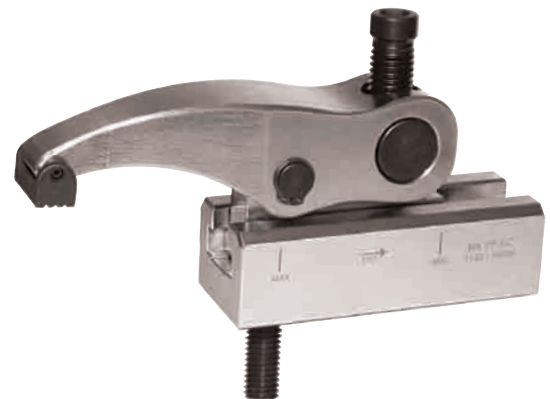
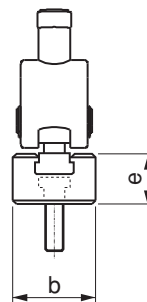
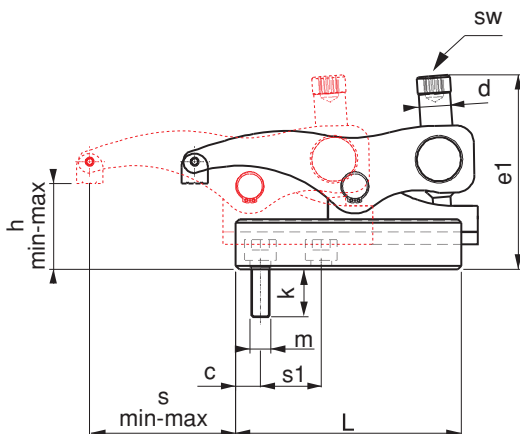

VORTEILE;

- Spannkraft 1600 kg - 2000 kg
- Verwendung in Löchern und T-Kanal
- Mit verschieben unterschiedliche Positionierungen möglich
- Unterschiedliche Spannweiten mittels Inbusschraube ohne Stütze
- Praktische Bauart ermöglicht einfaches und schnelles Spannen

ADVANTAGES

- 1600 kgf - 2000 kgf Clamping Force.
- Usings in the hole and "T" channel.
- Ability to be fixed in verious positions by sliding on the slide.
- It clamps high and low distances without support with the imbus bolt.
- It provides rapid and easy connection due to it's practical structure.

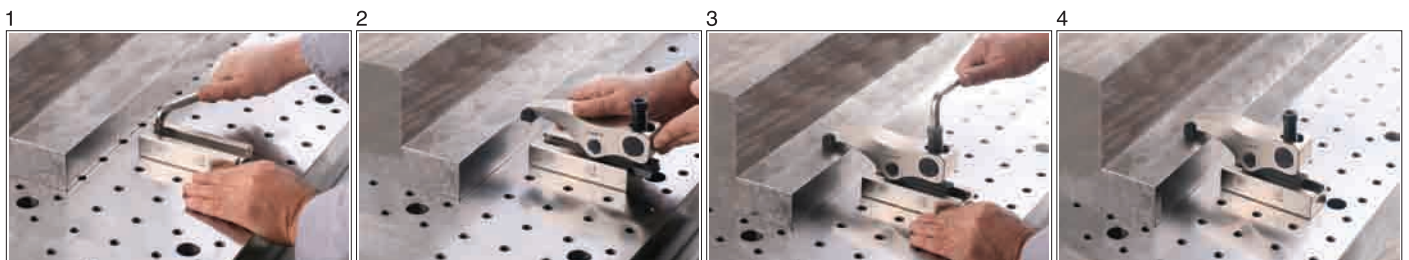

Referenz-Nr. Order No.		h		s	s1	e1	d	sw	L	e	b	c	k	Spannkraft Clamping Force Kgf	 (g)	
		min	max													
1150-116 M	M16	0	65	18-96	35	125	M20	12	140	43	55	19.5	26	2500	4340	
1150-118 M	M18	0	65	18-96	35	125	M20	12	140	43	55	19.5	30	2500	4360	
1150-120 M	M20	0	65	18-96	35	125	M20	12	140	43	55	19.5	30	2500	4370	
1160-220 M	M20	20	80	17-92	41.5	175	M24	12	24	178	55	74	24	34	5500	8880
1160-222 M	M22	20	80	17-92	41.5	175	M24	12	24	178	55	74	24	38	5500	8900
1160-224 M	M24	20	80	17-92	41.5	175	M24	12	24	178	55	74	24	44	5500	8920
1160-230 M	M30*	20	80	17-92	41.5	175	M24	12	24	178	55	74	24	51	5500	9110

1150

- Für Gewinde M16-M18-M20 Inbusschrauben 1150-516 / 1150-518 / 1150-520 verwenden
- Spannhöhe 0-65 mm
- Spannkraft 2500 kg

1160

- Für Gewinde M20-M22-M24-M30 Inbusschrauben 1160-620 / 1160-622 / 1160-624 / 1160-724 / 1160-730 verwenden
- Spannhöhe 20-80 mm
- Spannkraft 5500 kg

Hinweis: Die Bohrung für Zylinderschraube des Trägerelements von 1160-230M ist außerhalb der Standardabmessungen. Sie wird für diesen Artikel speziell gefertigt.

1150

- In the outer holes M16-M18-M20 are used with the Reference Nr. imbus bolt (1150-516)-(1150-518)-(1150-520).
- Height clamping gap of the piece is 0-65mm
- Clamping Force is 2500 kgf.

1160

- In the outer holes M20-M22-M24-M30 are used with the Reference Nr. imbus bolt (1160-620)-(1160-622)-(1160-624)-(1160-724)-(1160-730)
- Height clamping gap of the piece is 20-80mm
- Clamping Force is 5500 kgf.

Note: The drilling for cylinder head screw of the support element for 1160-230M is not standard. It is specially manufactured for this product.

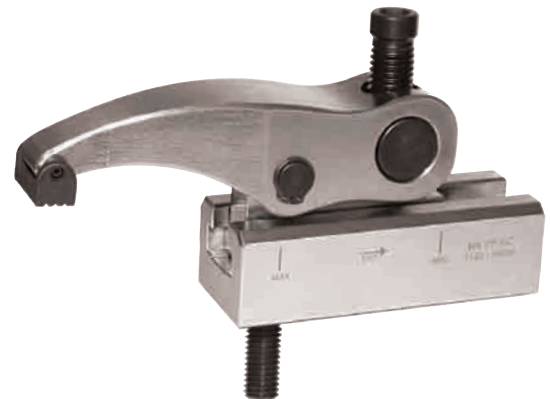
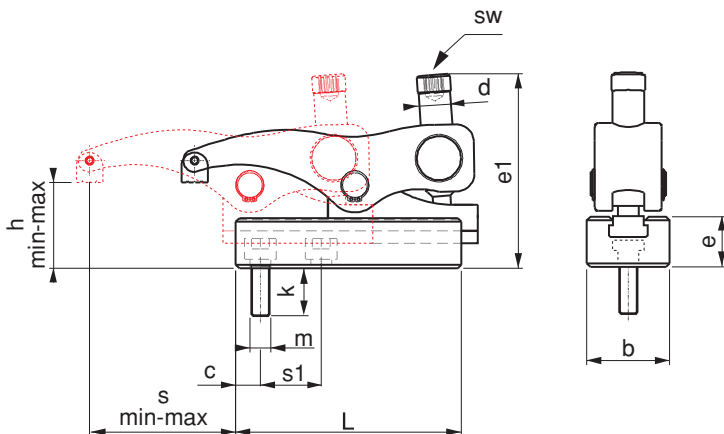
VORTEILE;

- Spannkraft 2500 kg - 5500 kg
- Verwendung in Löchern und T-Kanal
- Mit verschieben unterschiedliche Positionierungen möglich
- Unterschiedliche Spannweiten mittels Inbusschraube ohne Stütze
- Praktische Bauart ermöglicht einfaches und schnelles Spannen

ADVANTAGES

- 2500 kgf - 5500 kgf Clamping Force.
- Usings in the hole and "T" channel.
- Ability to be fixed in verious positions by sliding on the slide.
- It clamps high and low distances without support with the imbus bolt.
- It provides rapid and easy connection due to it's practical structure.

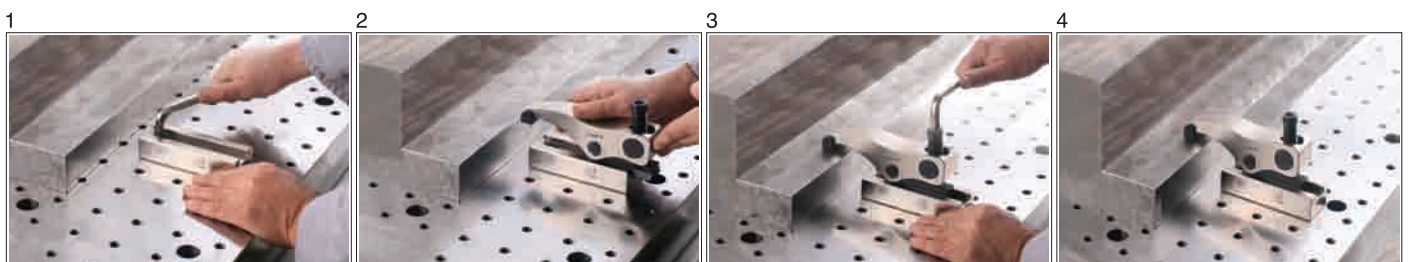

Referenz-Nr. Order No.		h		SW		
		min	max			
1120-0050	14-18	0	50	8	-	860
1130-0060	14-22	0	60	10	-	1680
1150-0062	18-28	0	65	12	-	2565
1160-2080	22-36	20	80	12	24	5050

1120-1130-1150-1160

- Kraftspanner obere Gruppe: Stahl geschmiedet
- Gehärtet

1120-1130-1150-1160

- Upper Slide Group: Forged Steel
- Hardened

Kraftspanner Oberteil

Upper Slide Group



Referenz-Nr. Order No.	g		L	b	e	
1120-045	M10 M12	14-18	104	38	35.5	750
1130-047	M12 M16	18-28	130	48	39	1275
1150-053	M16 M18 M20	18-28	140	55	42	1700
1160-074	M20 M22 M24	22-28	178	74	55	3650
1160-075	M30*	36	178	74	55	3650

1120-1130-1150-1160

- Gehärtet

1120-1130-1150-1160

- Hardened

Kraftspanner Grundelement

Body with Bottom T-Slide

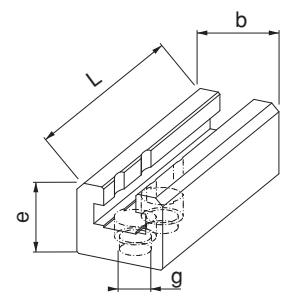

Referenz-Nr. Order No.	g		L	b	e	
1120-040	M10 M12	14	104	38	38	820
1130-045	M12 M16	14	130	48	45	1630
1150-048	M16 M18 M20	18	140	55	48	2070
1160-059	M20 M22 M24	28	178	74	55	3980

1120-1130-1150-1160

- Gehärtet

1120-1130-1150-1160

- Hardened

Kraftspanner Zwischenelement

Bottom Support

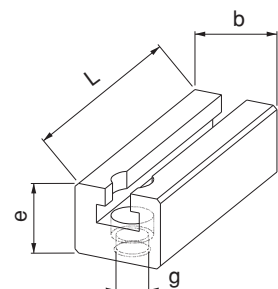

Spannschraubensatz

Clamp Lifting Bolt and Nut

Referenz-Nr. Order No.	m	L	SW		
1120-0714	M14	72	8	-	138
1130-0818	M18	83	10	-	235
1150-0920	M20	96	12	-	360
1160-1024	M24	134	12	24	795

1120-1130-1150-1160

- Gehärtet
- Schwarz beschichtet

1120-1130-1150-1160

- Hardened
- Black Coating

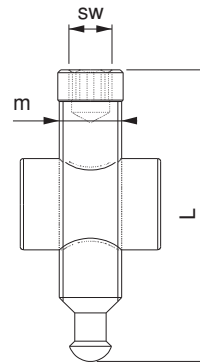

Referenz-Nr. Order No.	m	L	d	sw	
1120-312	M12	29	16.5	8	34
1130-412	M12	30	20.5	10	45
1130-416	M16	34	20.5	10	75
1150-516	M16	34	24.5	12	75
1150-518	M18	38	24.5	12	90
1150-520	M20	38	24.5	12	105
1160-620	M20	45	34	12	170
1160-622	M22	49	34	12	95
1160-624	M24	45	34	12	390
1160-724	M24	55	34	12	405
1160-730	M30*	66	38.5	12	400

1120-1130-1150-1160

- Für Gewindelöcher M12-M16-M18-M20
- Qualität 10.9
- Schwarz beschichtet

1120-1130-1150-1160

- For M12-M16-M18-M20 thread holes
- Quality 10.9
- Black Coating

Inbusschraube

Imbus Bolt for Fixing

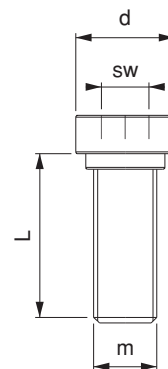

Referenz-Nr. Order No.		m	L	d	sw	
1120-512	12	M10	29	16.5	8	48
1120-514*	14	M12	29	16.5	8	54
1130-614*	14	M12	30	20.5	10	80
1130-616	16	M12	30	20.5	10	100
1130-618	18	M12	30	20.5	10	130
1130-620	20	M12	36	20.5	10	180
1130-622	22	M12	36	20.5	10	220
1150-718*	18	M16	34	24.5	12	145
1150-720	20	M16	34	24.5	12	190
1150-722	22	M16	42	24.5	12	260
1150-724	24	M16	42	24.5	12	350
1150-728	28	M16	42	24.5	12	470
1160-822	22	M20	45	34	12	320
1160-824	24	M20	45	34	12	410
1160-826*	28	M24	45	34	12	550
1160-828	28	M24	55	34	12	580
1160-832	32	M24	61	34	12	603
1160-836	36	M24	66	38.5	12	865

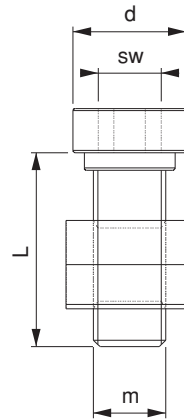

1120-1130-1150-1160

- (a) 14-28 T-Nut Fixier-Imbusschraube und T-Nut DIN 508
- Qualität 10.9
- Schwarz beschichtet
- Stützschrauben unten

1120-1130-1150-1160

- (a) 14-28 T-Slot fixing imbus bolt and T-Nut DIN 508
- Quality 10.9
- Black Coating
- Star-marked codes are bottom support bolts.

Referenz-Nr. Order No.	a	b	c	
1120-DP	13.5	26.5	12	15
1120-BSP	15.5	26.5	12	18
1120-ESP	18	26.5	12	21
1130-DP	17	32	15	20
1130-BSP	19	32	15	30
1130-ESP	22	32	15	30
1150-DP	19	38	18	40
1150-BSP	21	38	18	40
1150-ESP	25	38	18	50
1160-DP	22	44	22	55
1160-BSP	25	44	22	70
1160-ESP	28	44	22	80

1120-1130-1150-1160

- DP: Spannen flacher Werkstücke
- BSP: zylindrisch spannen in der Länge
- ESP: zylindrisch spannen in der Breite
- Schwarz beschichtet

1120-1130-1150-1160

- Product DP : Straight piece clamping
- Product BSP: Longitudinal cylinder clamping
- Product ESP: Lateril cylinder clamping
- Black Coating

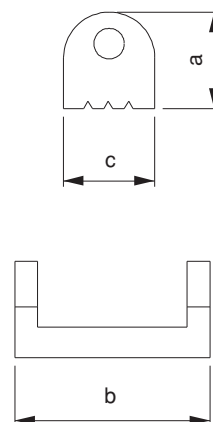

Spannbacke

Front Press Clamp



Referenz-Nr. Order No.		L	Nr.1330		e1	e2	b1	Nr.1610	h	Nr.1490 D x F	 (g)
			a1	b2							
1170-1010080	10	80	15	30	15	30	11	M10x10x80	10-35	M10x42	370
1170-1212100	12	100	20	40	21	40	14.5	M12x12x100	12-40	M12x50	740
1170-1212125	12	125	20	40	21	50	14.5	M12x12x160	12-85	M12x95	940
1170-1214100	14	100	20	40	21	40	14.5	M12x14x100	12-40	M12x50	705
1170-1214125	14	125	20	40	21	50	14.5	M12x14x160	12-85	M12x95	965
1170-1616125	16	125	25	50	26	45	18.5	M16x16x125	15-50	M16x62	1115
1170-1616160	16	160	25	50	26	65	18.5	M16x16x160	15-85	M16x97	1870
1170-1618125	18	125	25	50	26	45	18.5	M16x18x125	15-50	M16x62	1540
1170-1618160	18	160	25	50	26	65	18.5	M16x18x160	15-85	M16x97	1900
1170-2020160	20	160	30	60	30	60	22.5	M20x20x160	15-45	M20x62	1675
1170-2020200	20	200	30	60	30	80	22.5	M20x20x200	15-80	M20x97	3295
1170-2022160	22	160	30	60	30	60	22.5	M20x22x160	15-45	M20x62	2730
1170-2022200	22	200	30	60	30	80	22.5	M20x22x200	15-80	M20x97	3340
1170-2424160	24	160	30	70	35	60	26.5	M24x24x160	16-60	M24x81	3465
1170-2424200	24	200	30	70	35	80	26.5	M24x24x200	16-95	M24x116	4660
1170-2428160	28	160	30	70	35	60	26.5	M24x28x160	16-60	M24x81	5560
1170-2428200	28	200	30	70	35	80	26.5	M24x28x200	16-95	M24x116	4755

1170

- kompatibel mit "T-Nut" DIN 650

1170

- Product is suitable to DIN 650 T-Slot

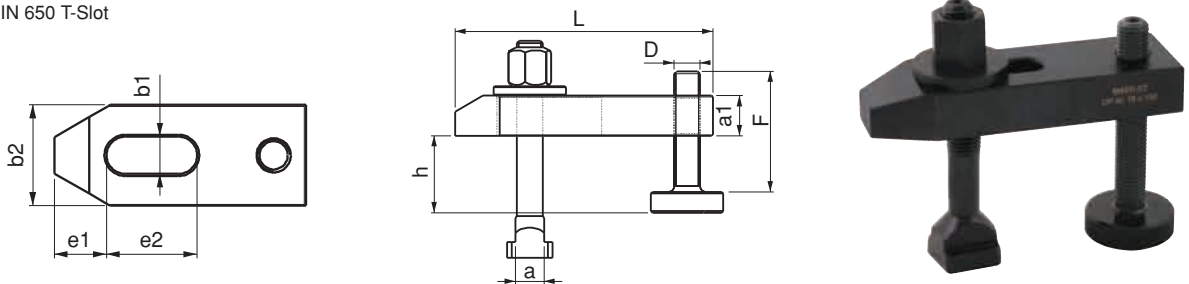

Referenz-Nr. Order No.		L	Nr.1450		e1	e2	b1	Nr.1610	h	Nr.1490 D x F	 (g)
			a1	b2							
1190-1010100	10	100	15	30	32	32	11	M10x10x80	26-50	M10x42	405
1190-1212125	12	125	20	40	40	40	14.5	M12x12x100	33-60	M12x50	870
1190-1214125	14	125	20	40	40	40	14.5	M12x14x100	37-60	M12x50	890
1190-1616160	16	160	25	50	49	50	18.5	M16x16x125	41-75	M16x62	1785
1190-1618160	18	160	25	50	49	50	18.5	M16x18x125	41-75	M16x62	1810
1190-2020200	20	200	30	60	55	70	22.5	M20x20x160	46-75	M20x62	3105
1190-2022200	22	200	30	60	55	70	22.5	M20x22x160	46-75	M20x62	3155
1190-2424200	24	200	35	70	72	60	26	M24x24x200	52-95	M24x81	4695
1190-2428200	28	200	35	70	72	60	26	M24x28x200	52-95	M24x81	4790

1190

- Verwendung in engen Bereichen
- kompatibel mit "T-Nut" DIN 650

1190

- This is used to gain from restricted height distances
- Product is suitable to DIN 650 T-Slot

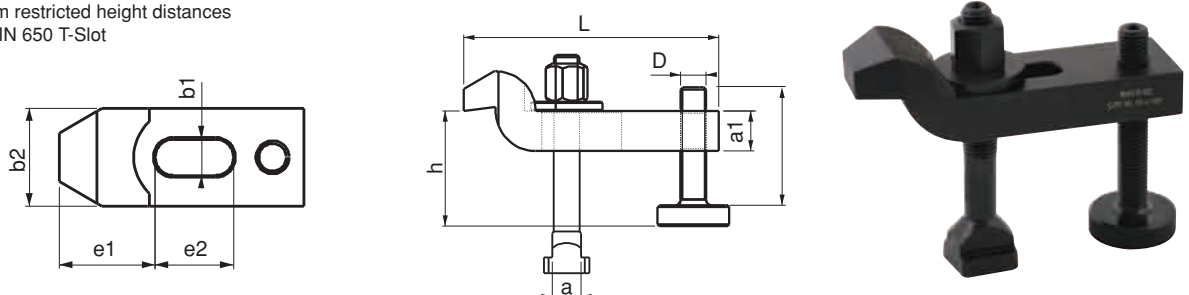

Referenz-Nr. Order No.		a1	a2	a3	b2xL	b3	e1	e2	h2	k	b1	m	h1	kgf	
1195-44115	10-12-14	27	12.5	12	44x115	30	25	30	21	11	13	M12	0-55	3000	506
1195-55150	12-14-16-18	36	18	17	55x150	41	35	36	23	12	17	M16	0-70	4000	1382
1195-63187	16-18-20-22	42	25	20	63x187	30	44	44	32.5	14	21	M20	0-80	6000	2241
1195-70235	20-22-24-28	51	36.5	24	70x235	30	60	47	34	17	25	M20	0-100	7500	3550

1195

- Material: Geschmiedeter Stahl
- Gehärtet
- Schwarz beschichtet

1195

- Material: Forged Steel
- Hardened
- Black coating

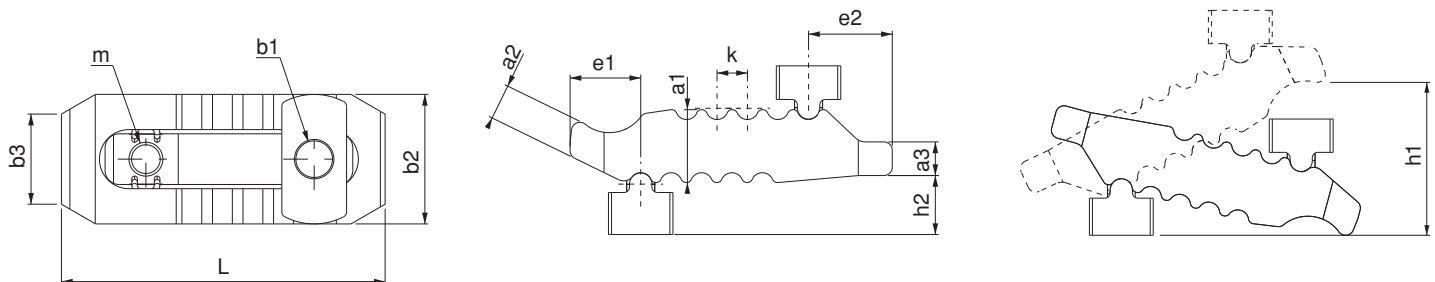

Spannpratze mit Gegenhalter, verstellbar

Combined Coupling Clamps Double Sided

Referenz-Nr. Order No.	b1	b2xL	e1	h1	k	m			Spannkraft Clamping Force Kgf	
1195-1010100	13	44x115	25	0-55	11	M12	10	M10x10x100	2500	613
1195-1212125	13	44x115	25	0-55	11	M12	12	M12x12x125	3000	686
1195-1214125	13	44x115	25	0-55	11	M12	14	M12x14x125	3000	705
1195-1212160	17	55x150	35	0-70	12	M16	12	M12x12x160	3500	1591
1195-1214160	17	55x150	35	0-70	12	M16	14	M12x14x160	3500	1610
1195-1616160	17	55x150	35	0-70	12	M16	16	M16x16x160	4000	1798
1195-1618160	17	55x150	35	0-70	12	M16	18	M16x18x160	4000	1818
1195-1616200	21	63x187	44	0-80	14	M20	16	M16x16x200	5500	2715
1195-1618200	21	63x187	44	0-80	14	M20	18	M16x18x200	5500	3018
1195-2020200	21	63x187	44	0-80	14	M20	20	M20x20x200	6000	3018
1195-2022200	21	63x187	44	0-80	14	M20	22	M20x22x200	6000	3060
1195-2020250	25	70x235	60	0-100	17	M20	20	M20x20x250	7000	4368
1195-2022250	25	70x235	60	0-100	17	M20	22	M20x22x250	7000	4410
1195-2424250	25	70x235	60	0-100	17	M20	24	M24x24x250	7500	4895
1195-2428250	25	70x235	60	0-100	17	M20	28	M24x28x250	7500	4966

1195

- kompatibel mit "T-Nut" DIN 650

1195

- Product is suitable to DIN 650 T-Slot

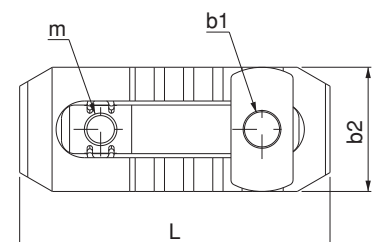
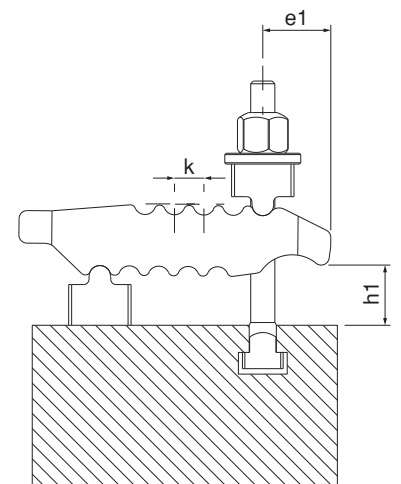

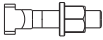
Referenz-Nr. Order No.	B1	D x F	 DIN 787	h1
1195-10101005013	13	M12x50	M10x10x100	15-31
1195-12121605013	13	M12x50	M12x12x160	15-97
1195-12141605013	13	M12x50	M12x14x160	15-97
1195-12122006217	17	M16x62	M12x12x200	18-126
1195-12142006217	17	M16x62	M12x14x200	18-126
1195-16162006217	17	M16x62	M16x16x200	18-126
1195-16182006217	17	M16x62	M16x18x200	18-126
1195-12122009717	17	M16x97	M12x12x200	18-120
1195-12142009717	17	M16x97	M12x14x200	18-120
1195-16162509717	17	M16x97	M16x16x250	39-161
1195-16182509717	17	M16x97	M16x18x250	39-161
1195-16162506221	21	M20x62	M16x16x250	18-129
1195-16182506221	21	M20x62	M16x18x250	18-129
1195-20202506221	21	M20x62	M20x20x250	18-129
1195-20222506221	21	M20x62	M20x22x250	18-129
1195-16162509721	21	M20x97	M16x16x250	18-151
1195-16182509721	21	M20x97	M16x18x250	18-151
1195-20203159721	21	M20x97	M20x20x315	42-184
1195-20223159721	21	M20x97	M20x22x315	42-184
1195-20203156225	25	M20x62	M20x20x315	21-147
1195-20223156225	25	M20x62	M20x22x315	21-147
1195-24243156225	25	M20x62	M24x24x315	21-147
1195-24283156225	25	M20x62	M24x28x315	21-147
1195-20203159725	25	M20x97	M20x20x315	21-182
1195-20223159725	25	M20x97	M20x22x315	21-182
1195-24243159725	25	M20x97	M24x24x315	21-182
1195-24283159725	25	M20x97	M24x28x315	21-182

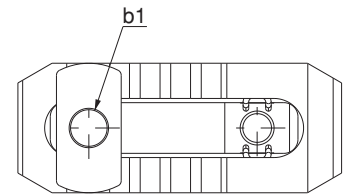
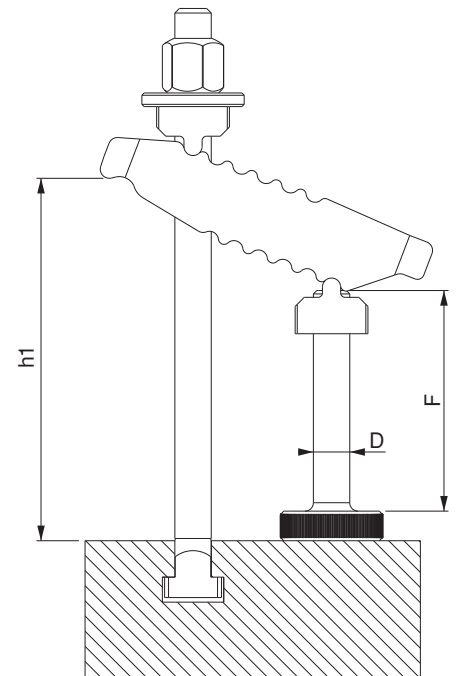



1195

- kompatibel mit "T-Nut" DIN 650

1195

- Product is suitable to DIN 650 T-Slot

Referenz-Nr. Order No.			b1	b2xL	d	e1	e2	h	
1200-50140	-	-	17	50x140	60	30	55	75	900
1200-60175	-	-	21	60x175	80	40	70	85	1600
1200-12125	12	M12x12x125	17	50x140	60	30	55	0-50	1070
1200-14125	14	M12x14x125	17	50x140	60	30	55	0-55	1080
1200-16160	16	M16x16x160	17	50x140	60	30	55	0-75	1270
1200-18160	18	M16x18x160	17	50x140	60	30	55	0-75	1280
1200-20200	20	M20x20x200	21	60x175	80	40	70	0-85	2300
1200-22200	22	M20x22x200	21	60x175	80	40	70	0-85	2370

1200

- Material: Geschmiedeter Stahl
- Gehärtet
- Verzinkt

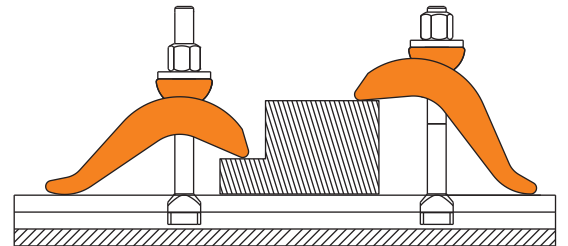
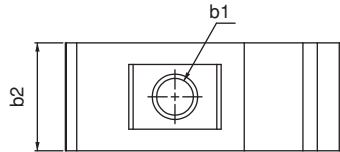
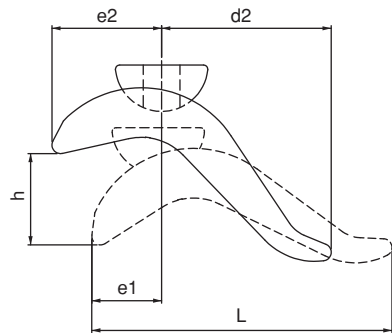

1200

- Material: Forged Steel
- Hardened
- Zinc Coating

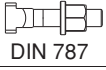

Spannpratze

Stepped Coupling Clamp

Referenz-Nr. Order No.	b1			m	h	b x L	c	d	e1	k x3	
1205-017	17	16-18	-	93	15-50	65x165	39	128	30	17	2.10
1205-021	21	20-22	-	111	20-65	75x189	43	146	33	19	3.20
1205-025	25	24-28	-	126	20-75	85x213	49	164	39	21	4.50
1205-031	31	36	-	143.5	20-85	95x238	56	182	46	23	6.30
1205-016	17	16	M16x16x125	93	15-50	65x165	39	128	30	17	2.50
1205-018	17	18	M16x18x125	93	15-50	65x165	39	128	30	17	2.50
1205-020	21	20	M20x20x160	111	20-65	75x189	43	146	33	19	3.90
1205-022	21	22	M20x22x160	111	20-65	75x189	43	146	33	19	3.90
1205-024	25	24	M24x24x200	126	20-75	85x213	49	164	39	21	5.70
1205-028	25	28	M24x28x200	126	20-75	85x213	49	164	39	21	5.70
1205-036	31	36	M30x36x250	143.5	20-85	95x238	56	182	46	23	8.80

1205

- Verwendung im Bereich 15-85 mm ohne Stütze
- Material: Geschmiedeter Stahl
- Gehärtet
- Verzinkt

1205

- It provides using between 15-85 mm without supporting.
- Material: Forged Steel
- Hardened
- Zinc Coating

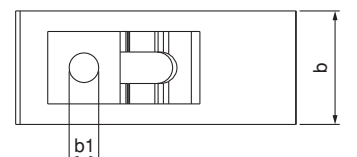
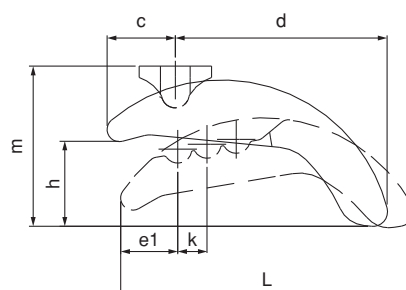

Referenz-Nr. Order No.	b1	a	DIN 787	m	h	b x L	c	d	e1	k x4	(g)
1210-013	13	12-14	-	52	0-40	40x90	28	48	23	14	340
1210-017	18	16-18	-	80	0-60	58x130	38	74	29	18	990
1210-021	22	20-22	-	98	0-75	68x140	46	80	32	20	1450
1210-025	26	24-28	-	110	0-90	78x175	52	100	39	24	2360
1210-012	13	12	M12x12x100	52	0-40	40x90	28	48	23	14	400
1210-014	13	14	M12x14x100	52	0-40	40x90	28	48	23	14	420
1210-016	18	16	M16x16x160	80	0-60	58x130	38	74	29	18	1140
1210-018	18	18	M16x18x160	80	0-60	58x130	38	74	29	18	1145
1210-020	22	20	M20x20x200	98	0-75	68x140	46	80	32	20	1560



1210

- Verwendung im Bereich 0-75 mm ohne Stütze
- Material: Geschmiedeter Stahl
- Gehärtet
- Verzinkt

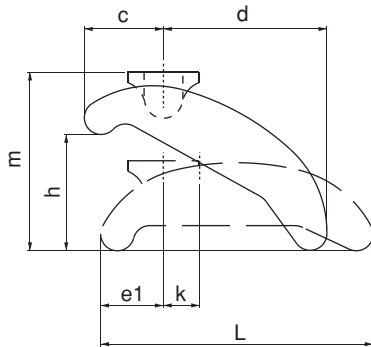

1210

- It provides using between 0-75 mm without supporting.
- Material: Forged Steel
- Hardened
- Zinc Coating

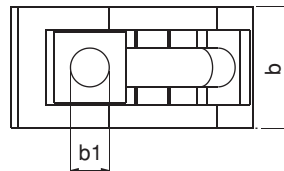

Referenz-Nr. Order No.	a	h min - max	f	c	L	b	(g)
1230-01	14-16-18-20-22	40 - 80	5	16	110	38	1200
1230-02		70 - 125	10	16	110	38	1490
1230-03		120 - 175	10	18	110	38	2700
1230-04		170 - 225	10	23	110	38	4260

1230

- beidseitig verwendbar Feinabstufung der Rastentreppe ermöglicht Verwendung in engen Bereichen
- kompatibel mit "T-Nut" DIN 650
- Spanneisen: gehärtet
- Schraube: 10.9
- Körper: statisch lackiert, Rest Schwarz beschichtet

1230

- Double-sided usage of the clamp provides using advantage in restricted areas
- Product is suitable to DIN 650 T-Slot
- Clamp Material: Hardened
- Bolt Quality: 10.9
- Body is statically painted and the other parts are black coated

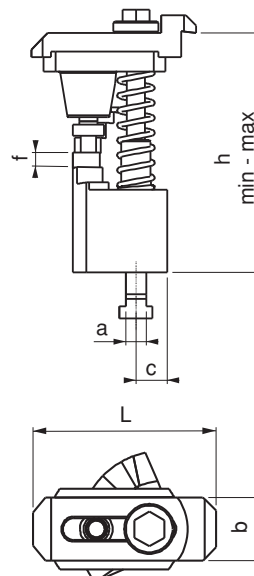

Stufenpratze

Stepped Combined Clamp



Referenz-Nr. Order No.		h min-max	f	c	L	b	m	sw	Spannkraft Clamping Force Kgf	Nm	
1250 - 02	14-16-18-20-22	80-137	3	17	110	38	M12	19	2250	85	2015
1250 - 03		125-224	3	17	110	38	M12	19	2250	85	2910
1250 - 04		160-300	3	17	110	38	M12	19	2250	85	3665



1250

- beidseitig verwendbar Feinabstufung der Rastentreppe ermöglicht Verwendung in engen Bereichen
- kompatibel mit "T-Nut" DIN 650
- Spanneisen: gehartet
- Schraube: 10.9
- Schwarz beschichtet

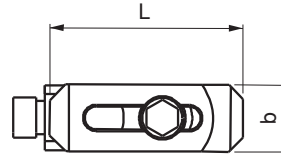

1250

- Double-sided usage of the clamp and it's stepped lifter's support provides using advantage in restricted areas
- It is suitable to DIN 650 T-Slot
- Clamp Hardness: Hardened
- Bolt Quality: 10.9
- Black coating

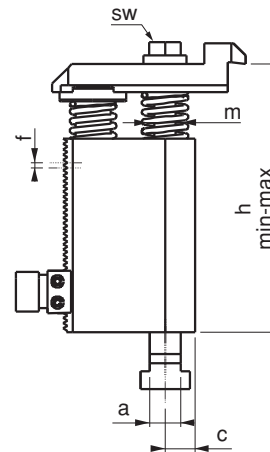

Spannpratze stufenlos verstellbar

Unsupported Suspension Clamp

Referenz-Nr. Order No.		h min-max		b1	e	z	L	b	
1270-1012	12	0-45	M10x12x125	11	48	61	109	40	660
1270-1214	14	0-45	M12x14x125	13	48	61	109	40	705
1270-1416	16	0-55	M14x16x125	15	57	72	129	50	1190
1270-1618	18	0-55	M16x18x125	17	57	72	129	50	1265

Ürün Nr. 1270 Desteksiz Askı Pabuç

- Verwendung ohne Stütze 0-55 mm
- Material: Geschmiedeter Stahl
- Spanneisen: gehartet
- Schraube: 12.9
- Verzinkt

Product Nr. 1270 Unsupported Suspension Clamp

- Product provides using between 0-55 mm without using support
- Material: Forged Steel
- Clamp Hardness: Hardened
- Bolt Quality: 12.9
- Zinc Coating

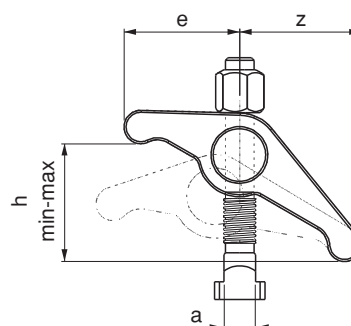
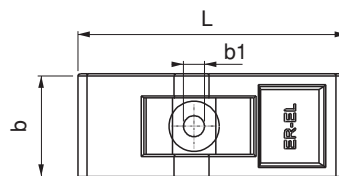

Referenz-Nr. Order No.	a	b	c	d	e	m	sw	m1	imbus	Spannkraft Clamping Force Kgf	Drehmoment Allowable Screw Torque (N-m)	 (g)
1275-3012	30	28	16	40	23	M12	30	M8	M10	750	20	300
1275-5012	50	32	20	45	40	M12	36	M12	M12	1000	30	500
1275-5016	50	32	20	45	40	M16	36	M12	M12	1000	30	510
1275-6016	60	40	25	45	45	M16	41	M16	M16	1250	45	750



1275

- Verwendung in engen Bereichen
- Gehärtet
- Schwarz beschichtet

1275

- Function working in restricted areas
- Hardened
- Black coated

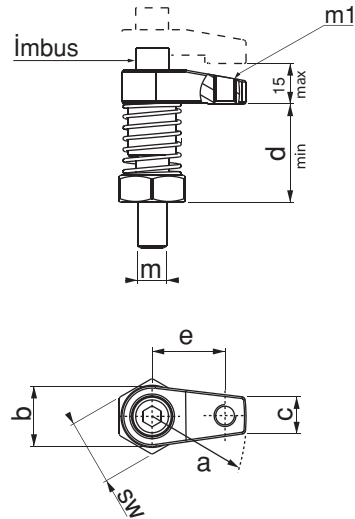
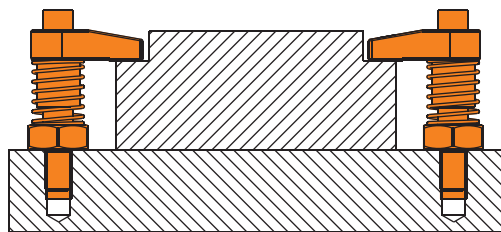

Spannpratze

Combined Clamp With Bush

Referenz-Nr. Order No.	a	Ø b h7	c	d	e	f	g	m	m1	j	Spannkraft Clamping Force Kgf	 (g)
1280-3010	30	22	58	80	28	16	30	M10	M8	23	750	220
1280-5012	50	26	70	90	32	20	40	M12	M12	40	1100	400
1280-6016	60	32	74	95	40	25	40	M16	M16	45	1250	610



1280

- Verwendung in engen Bereichen, auf Platten
- Gehärtet
- Schwarz beschichtet

1280

- Function working in restricted areas and variety application at plate
- Hardened
- Black coated

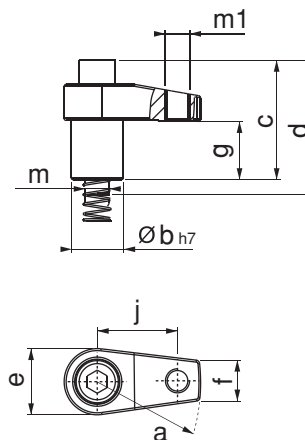

Referenz-Nr. Order No.	a (F7)	b	c	m	
1280-3010	22	30	20	M10	
1280-5012	26	40	25	M12	
1280-6016	32	40	25	M16	

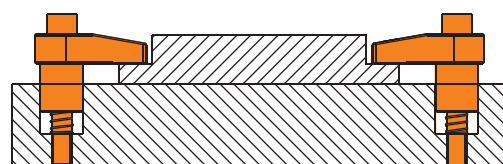

Referenz-Nr. Order No.	a	b	m	d	sw	 (g)
1282-0825	25	12	M8	8	14	10
1282-1030	30	17	M10	10	17	30
1282-1235	35	22	M12	12	22	65
1282-1642	42	26	M16	14	27	125

1282

- für plane und saubere Flächen, kompatibel mit Nr. 1275 und 1280
- Gehärtet
- Schwarz beschichtet

1282

- It is applicable with Nr. 1275 and 1280 for graded clean surfaces.
- Hardened
- Black coated

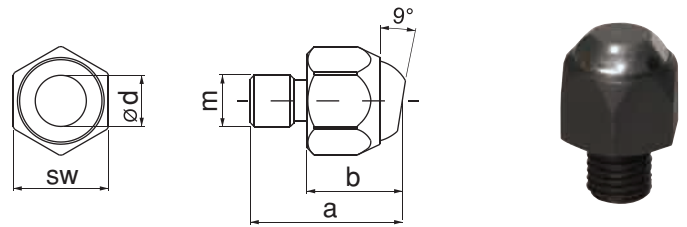

Referenz-Nr. Order No.	a	b	m	d	sw	 (g)
1283-0825	25	12	M8	8	14	10
1283-1030	30	17	M10	10	17	30
1283-1235	35	22	M12	12	22	60
1283-1642	42	26	M16	14	27	120

1283

- für plan-saubere Flächen
- Gehärtet
- Schwarz beschichtet

1283

- Its clamping surface is designed with bead graded bad surfaces.
- Hardened
- Black coated

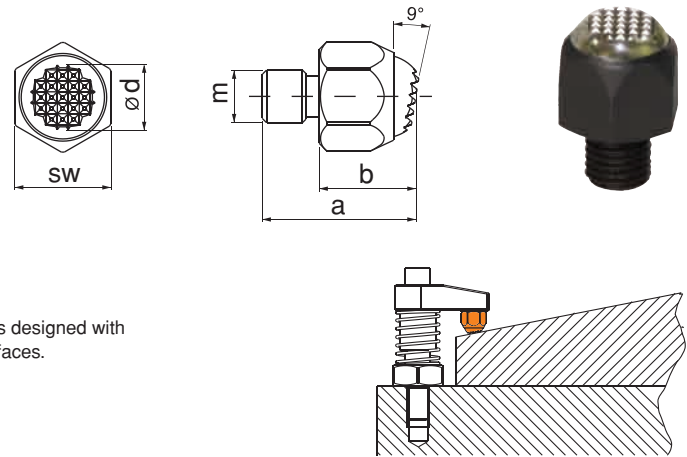

Referenz-Nr. Order No.	a	b F7	c	d	e	f	m	h	 (g)
1285-12080	80	26	36	40	110	M12	M12	40	600
1285-12100	100	26	36	40	130	M12	M12	40	795
1285-16080	80	32	46	50	110	M16	M16	40	945
1285-16100	100	32	46	50	130	M16	M16	40	1230

1285

- verwendbar mit Nr. 1280 zum Spannen hoher Werkstücke
- Gehärtet
- Schwarz beschichtet

1285

- It is used together with Nr. 1280 for clamping high pieces.
- Hardened
- Black coated

Distanzhülse
Support to The Hive

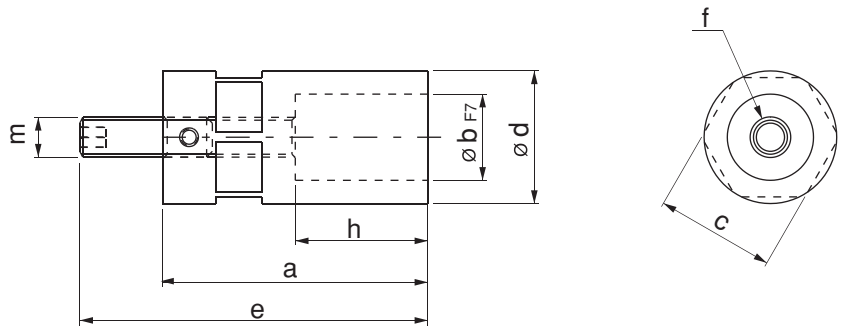
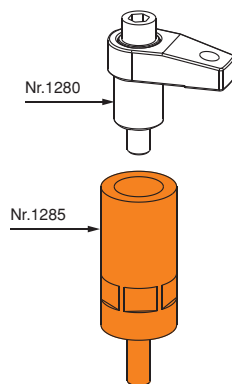

Spannelemente

Clamping Components



Referenz-Nr. Order No.	a ($\begin{smallmatrix} 0 \\ -0.13 \end{smallmatrix}$)	b	 (g)
1287-CT9120	12	7.8	13

1287

- Gehärtet
- Schwarz beschichtet

1287

- Hardened
- Black coating

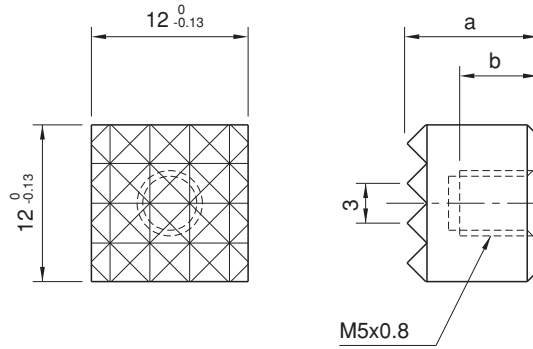

Referenz-Nr. Order No.	a ($\begin{smallmatrix} 0 \\ -0.13 \end{smallmatrix}$)	b ($\begin{smallmatrix} 0 \\ -0.13 \end{smallmatrix}$)	d	p	 (g)
1287-HS9102	10	12	M5x0.8	2.3	7.5
1287-HS9122	12	12	M5x0.8	3	11
1287-HS9160	16	12	M6x1	3	17
1287-HS9202	20	12	M5x0.8	3	33.5
1287-HS9252	25	12	M6x1	3	53

1287

- Gehärtet
- Schwarz beschichtet

1287

- Hardened
- Black coating

Druckstück

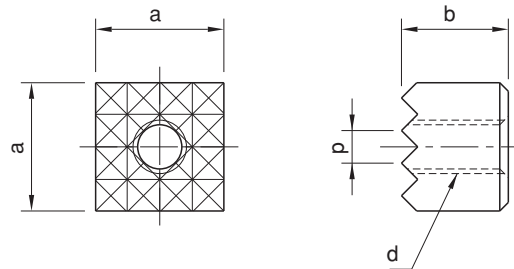

Referenz-Nr. Order No.	a ($\begin{smallmatrix} 0 \\ -0.13 \end{smallmatrix}$)	b ($\begin{smallmatrix} 0 \\ -0.13 \end{smallmatrix}$)	c	d	 (g)
1287-HS9122C	12	12	6.5	M4	10
1287-HS9160C	16	12	4.5	M4	16
1287-HS9202C	20	12	5.5	M5	31
1287-HS9252C	25	12	4.5	M6	49

1287

- Gehärtet
- Schwarz beschichtet

1287

- Hardened
- Black coating

Druckstück

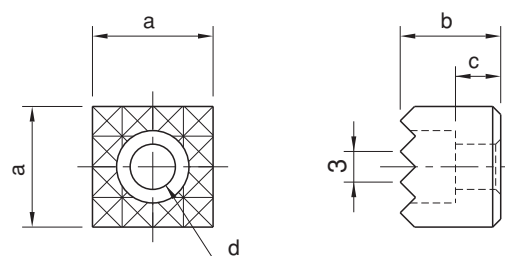

Referenz-Nr. Order No.	a ($\begin{smallmatrix} 0 \\ -0.13 \end{smallmatrix}$)	b ($\begin{smallmatrix} 0 \\ -0.13 \end{smallmatrix}$)	c	d	f	g	p	 (g)
1288-CT102	10	12	6	7.9	M5x0.8	8	2.3	6
1288-CT122	12	12	6	9.5	M5x0.8	8	3	9
1288-CT162	16	12	6	12.7	M6x1	7.8	3	17
1288-CT202	20	12	6	15.9	M6x1	7.8	3	28
1288-CT252	25	12	6	19.1	M6x1	7.8	3	43

1288

- Gehärtet
- Schwarz beschichtet

1288

- Hardened
- Black coating

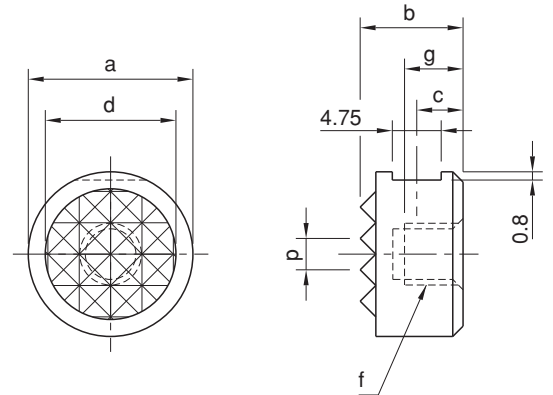

Druckstück

Referenz-Nr. Order No.	a ($\begin{smallmatrix} 0 \\ -0.13 \end{smallmatrix}$)	b ($\begin{smallmatrix} 0 \\ -0.13 \end{smallmatrix}$)	d	e	p	 (g)
1288-HS102	10	12	M5x0.8	6	2.3	6
1288-HS122	12	12	M5x0.8	6	3	9
1288-HS162	16	12	M6x1	6	3	15
1288-HS202	20	12	M6x1	6	3	25
1288-HS252	25	12	M6x1	6	3	40

1288

- Gehärtet
- Schwarz beschichtet

1288

- Hardened
- Black coating

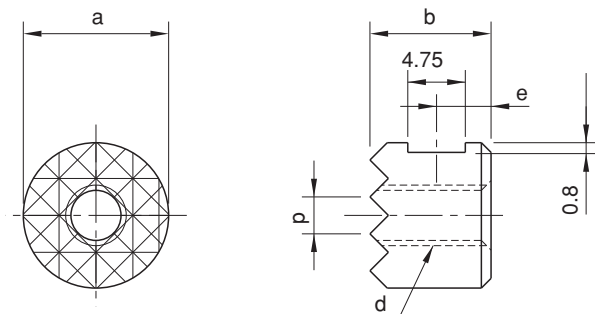

Druckstück

Referenz-Nr. Order No.	a ($\begin{smallmatrix} 0 \\ -0.13 \end{smallmatrix}$)	b ($\begin{smallmatrix} 0 \\ -0.13 \end{smallmatrix}$)	c	d	 (g)
1288-HS122C	12	12	6.5	M4	8
1288-HS162C	16	12	6.5	M4	15
1288-HS202C	20	12	6.5	M5	23
1288-HS252C	25	12	6.5	M6	38

1288

- Gehärtet
- Schwarz beschichtet

1288

- Hardened
- Black coating

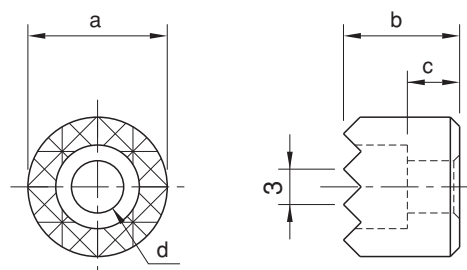

Referenz-Nr. Order No.	L	b1	Gewinde metric	Zollgewinde whitworth	a	b2	b3	e1	e2	(g)
1290-06050	50	6.6	M6	1/4	10	20	8	10	20	50
1290-06080	80								30	95
1290-08060	60	9	M8	5/16	12	25	10	13	22	100
1290-08100	100								45	170
1290-10080	80	11	M10	3/8	15	30	12	15	30	190
1290-10100	100								45	225
1290-12100	100	14.5	M12-M14	1/2	20	40	14	21	45	435
1290-12125	125								55	580
1290-16125	125	18.5	M16-M18	5/8	25	50	18	26	55	855
1290-16160	160								65	1175



- 1290**
- kompatibel mit Nr. 1310
 - Gehärtet
 - Schwarz beschichtet

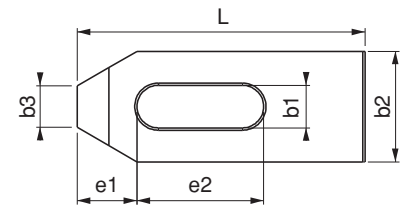

- 1290**
- Product is used with Nr. 1310 Serrated Support
 - Hardened
 - Black Coating

Spannunterlagen mit Treppenzähnen

Serrated Thread Support

Referenz-Nr. Order No.	h-H	a	b	c	min-max	(g)
1310-01	37-85	57	35	60	0-40	505
1310-02	48-112	73	45	76	0-60	825
1310-03	58-139	90	55	93	0-75	1250
1310-04	66-165	108	64	111	0-90	685

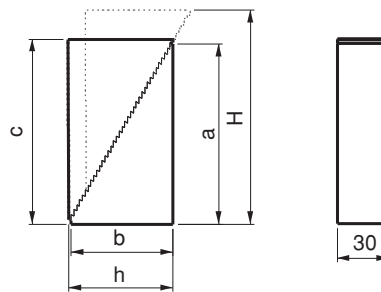

- 1310**
- kompatibel mit Nr. 1290
 - Schwarz beschichtet

- 1310**
- Product is used with Nr. 1290 Serrated Thread Clamp
 - Black Coating

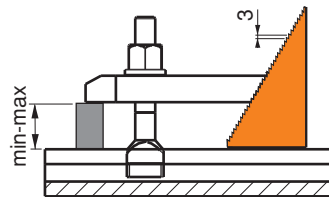

Gabelspanneisen abgeschrägt

Bifurcated Clamp

Referenz-Nr. Order No.	b1	L1	Gewinde metric	Zollgewinde whitworth	a	b2	b3	L2	L3	(g)
1320-08100	9	100	M8	5/16	15	30	16	32	18	240
1320-10125	11	125	M10	3/8	20	30	20	38	24	380
1320-12160	14.5	160	M12-M14	1/2	25	40	24	47	30	800
1320-12200	14.5	200	M12-M14	1/2	25	40	24	47	30	950
1320-16200	18.5	200	M16-M18	5/8	30	50	28	57	36	1500
1320-16250	18.5	250	M16-M18	5/8	30	50	28	57	36	1850
1320-20250	22.5	250	M20-M22	3/4	40	60	35	68	45	2900
1320-20315	22.5	315	M20-M22	3/4	40	60	35	68	45	3600
1320-24250	26	250	M24	1	40	70	43	83	56	3400
1320-24315	26	315	M24	1	40	70	43	83	56	4300
1320-30315	33	315	M30	1 1/4	50	80	50	88	56	6000
1320-30400	33	400	M30	1 1/4	50	80	50	88	56	7300



- 1320**
- Gehärtet
 - Schwarz beschichtet

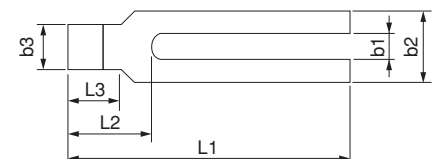

- 1320**
- Hardened
 - Black Coating

Referenz-Nr. Order No.	L	b1	Gewinde		a	b2	b3	e1	e2	d	(g)	
			Gewinde metric	Zollgewinde whitworth								
1330-06050	50	6,6	M6	1/4	10	20	8	10	20	M8	50	
1330-08060	60	9	M8	5/16	12	25	10	13	22	M8	105	
1330-10080	80	11	M10	3/8	15	30	12	15	30	M10	210	
1330-12100	100	14,5	M12-M14	1/2	20	40	14	21	40	M12	465	
1330-12125	125							21	50		590	
1330-16125	125	18,5	M16-M18	5/8	25	50	18	26	45	M16	930	
1330-16160	160							26	65		1200	
1330-20160	160	22,5	M20-M22	3/4	30	60	22	30	60	M20	1710	
1330-20200	200								80		100	2170
1330-20250	250								100		100	3885
1330-24160	160	26	M24	1	30	70	26	35	60	M24	1965	
1330-24200	200								80		100	2920
1330-24250	250								100		100	3720
1330-24315	315								100		100	6435
1330-30250	250								33		M30	1 1/4
1330-30315	315	130	100	7665								
1330-36400	400	43	M36-M42	1 1/2	58	100	43	100	150	M30	14490	

1330

- Gehärtet
- Schwarz beschichtet

1330

- Hardened
- Black Coating

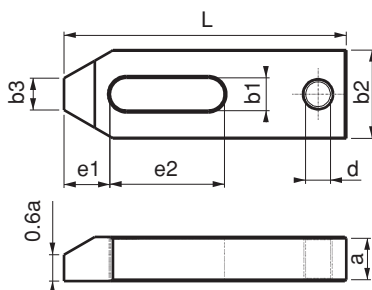

Referenz-Nr. Order No.	L	b1	Gewinde		a	b2	b3	e1	e2	(g)		
			Gewinde metric	Zollgewinde whitworth								
1350-06050	50	6,6	M6	1/4	10	20	8	10	20	60		
1350-08060	60	9	M8	5/16	12	25	10	13	22	110		
1350-10080	80	11	M10	3/8	15	30	12	15	30	185		
1350-12100	100	14,5	M12-M14	1/2	20	40	14	21	40	480		
1350-12125	125							21	50		610	
1350-16125	125	18,5	M16-M18	5/8	25	50	18	26	45	980		
1350-16160	160							26	65		1240	
1350-20160	160	22,5	M20-M22	3/4	30	60	22	30	60	1795		
1350-20200	200								80		100	2255
1350-24200	200								100		100	2570
1350-24250	250	26	M24	1	30	70	26	35	100	3875		
1350-30250	250	33	M30	1 1/4	40	80	34	45	100	4990		
1350-30315	315							130	100		7885	
1350-36400	400	43	M36-M42	1 1/2	60	100	43	100	150	14450		

DIN 6314

1350

- Gehärtet
- Schwarz beschichtet

1350

- Hardened
- Black Coating

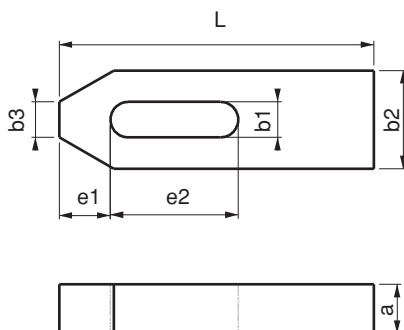

Spanneisen gerade

Straight Clamp



Referenz-Nr. Order No.	L	b1	Gewinde		a	b2	a1xa2	b3	e1	e2	d	
			Gewinde metric	Zollgewinde whitworth								
1370-10080	80	11	M10	3/8	15	30	5x8	12	15	30	M10	180
1370-12100	100	14.5	M12-14	1/2	20	40	8x10	14	21	40	M12	410
1370-12125	125									50		590
1370-16125	125	18.5	M16-18	5/8	25	50	10x12.5	18	26	45	M16	910
1370-16160	160									65		1180
1370-20160	160	22.5	M20-22	3/4	30	60	12x15	22	30	60	M20	1575
1370-20200	200									80		2150
1370-24160	160	26	M24	1	30	70	12x15	26	35	60	M24	1800
1370-24200	200				35		14x17			80		2875
1370-24250	250				35		14x17			100		3500

1370

- verwendbar in engen Bereichen
- Gehärtet
- Schwarz beschichtet



1370

- This product is used in restricted areas with the purpose of gaining height
- Hardened
- Black Coating

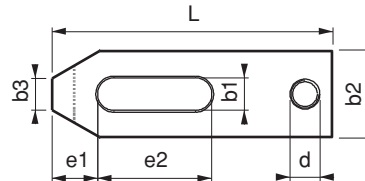

Referenz-Nr. Order No.	L	b1	Gewinde		a	b2	b3	b4	
			Gewinde metric	Zollgewinde whitworth					
1390-06060	60	6.6	M6	1/4	12	19	6.2	3	65
1390-08080	80	9	M8	5/16	15	25	8	4	140
1390-10100	100	11	M10	3/8	20	30	9.5	5	240
1390-12125	125	14.5	M12-M14	1/2	25	38	12	6	700
1390-12160	160								915
1390-12200	200	18.5	M16-M18	5/8	27	48	15	8	945
1390-16160	160				27				1215
1390-16200	200				37				2000
1390-16250	250	22.5	M20-M22	3/4	37	52	15	10	1650
1390-20200	200				37				2765
1390-20250	250				37				3510
1390-20315	315				47				7200
1390-20500	500	26	M24	1	37	66	20	10	2260
1390-24200	200				37				2740
1390-24250	250				37				3515
1390-24315	315				47				7100
1390-24500	500				33				M30
1390-30250	250	47	4190						
1390-30315	315	47	5735						
1390-30400	400	46	8455						
1390-30600	600	57	28000						
1390-301000	1000	40	M36	1 1/2		57	100	30	
1390-36400	400				57	16500			
1390-36600	600				43	M42			1 1/2
1390-42600	600	77	28800						

DIN 6315B

1390

- Erleichterung bei Stufenspannen in engen Bereichen
- Gehärtet
- Schwarz beschichtet

1390

- Due to the structure of the clamp, this product provides convenience for the couplings of formed work pieces on graded surfaces
- Hardened
- Black Coating

Gabelspanneisen abgescrängt

Bifurcated Clamp

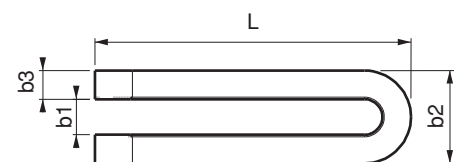

Referenz-Nr. Order No.	L	b1	Gewinde		a	b2	a1xa2	e1	e2	h	 (g)
			Gewinde metric	Zollgewinde whitworth							
1387-12070	70	13	M12	1/2	21.5	40	8x6	11	40	14	255
1387-16070	70	17	M16	5/8	29.5	40	10x7	11	40	22	290



1387

- Vorteil : arbeitet ohne Heber
- Gehärtet
- Schwarz beschichtet

1387

- Provides the advantage of working without support.
- Hardened
- Black coated

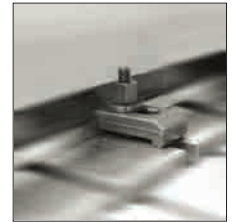
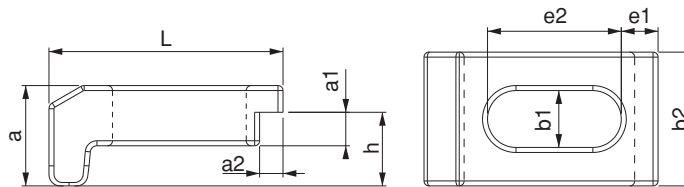

Gabelspanneisen mit Stufe und Stützgewinde

Bifurcated Clamp with Stepped Support Hole

Referenz-Nr. Order No.	L	b1	Gewinde		a	e2	a1xa2	b2	d	 (g)
			Gewinde metric	Zollgewinde whitworth						
1400-10100	100	11	M10	3/8	20	70	10x10	30	M10	260
1400-12125	125	14.5	M12-14	1/2	25	90	12x12	40	M12	565
1400-16160	160	18.5	M16-18	5/8	30	110	15x15	50	M16	1235
1400-20200	200	22.5	M20-22	3/4	40	135	20x20	60	M20	2460



1400

- Gehärtet
- Schwarz beschichtet

Erleichterung bei Stufenspannen in engen Bereichen.

It provides usage advantage in gradual and limited areas.

1400

- Hardened
- Black Coating

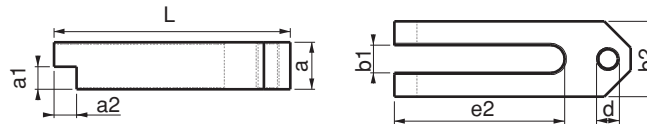

Gabelspanneisen mit Stützgewinde

Bifurcated Clamp with Support Hole

Referenz-Nr. Order No.	L	b1	Gewinde		a	e1	e2	b2	d	 (g)
			Gewinde metric	Zollgewinde whitworth						
1410-10100	100	11	M10	3/8	20	5	70	30	M10	260
1410-12125	125	14.5	M12-14	1/2	25	6	90	40	M12	560
1410-16160	160	18.5	M16-18	5/8	30	8	110	50	M16	1230
1410-20200	200	22.5	M20-22	3/4	40	10	135	60	M20	1490



1410

- Gehärtet
- Schwarz beschichtet

Erleichterung bei Stufenspannen in engen Bereichen.

It provides usage advantage for gradual parts during forward tightenings.

1410

- Hardened
- Black Coating

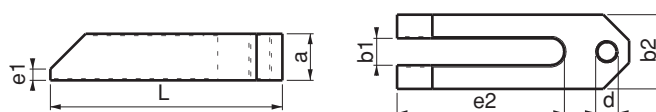

Referenz-Nr. Order No.	L	b1	Gewinde		a	a2	b2	b3	c	e1	e2	d	 (g)
			Gewinde metric	Zollgewinde whitworth									
1450-06060	60	6.6	M6	1/4	10	20	20	10	8	20	20	M8	80
1450-08080	80	9	M8	5/16	12	24	25	12	9	25	25	M8	170
1450-10100	100	11	M10	3/8	15	30	30	15	12	32	32	M10	245
1450-12125	125	14.5	M12-M14	1/2	19	40	38	20	16	40	40	M12	600
1450-16125	125	18.5	M16-M18	5/8	24	50	48	25	20	49	40	M16	925
1450-16160	160										50		1205
1450-20160	160	22.5	M20-M22	3/4	29	58	58	30	24	55	55	M20	1705
1450-20200	200										70		2145
1450-24160	160									53	55		2110
1450-24200	200	26	M24	1	33	70	70	35	28	72	60	M24	3070
1450-24250	250									72	80		3710
1450-30250	250	33	M30	1 1/4	38	80				91	80	M24	4635
1450-30315	315				48	100	77	40	40		100		7050



DIN 6316

1450

- Dieses Produkt bietet den Vorteil, von der Höhe und den Durchgängen der Schraube zu profitieren.
- Gehärtet
- Schwarz beschichtet

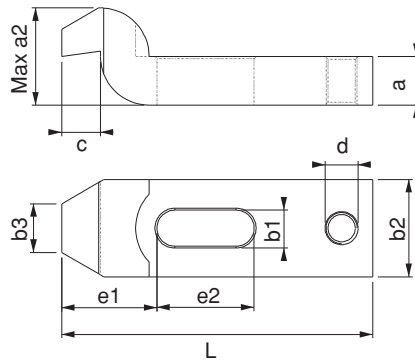

1450

- This product provides advantage to gain from the height and in the passings of the bolt
- Hardened
- Black Coating



Gabelspanneisen mit rundem Spannansatz

Referenz-Nr. Order No.	L1	b1	Gewinde		a	b2	Ød	L2	L3	 (g)
			Gewinde metric	Zollgewinde whitworth						
1470-08100	100	9	M8	5/6	15	30	12	30	18	180
1470-10125	125	11	M10	3/8	20	30	16	36	24	290
1470-12160	160	14.5	M12-M14	1/2	25	40	20	45	30	715
1470-12200	200									815
1470-16200	200	18.5	M16-M18	5/8	30	50	24	55	36	1210
1470-16250	250									1550
1470-20250	250	22.5	M20-M22	3/4	40	60	30	65	45	2680
1470-20315	315									3435
1470-24250	250	26	M24	1	40	70	38	80	56	3060
1470-24315	315									4120
1470-30315	315	34	M30	1 1/4	50	80	45	85	56	5600
1470-30400	400									7135



DIN 6315C

1470

- Befestigung Werkstücke mit Loch in der Spannfläche
- Gehärtet
- Schwarz beschichtet

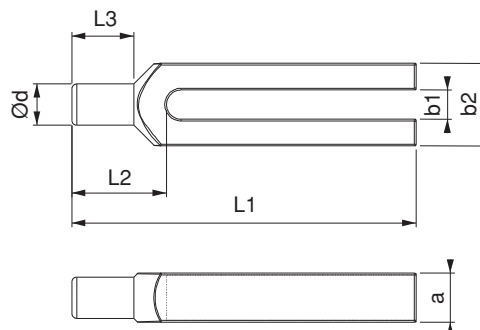

1470

- This product fixes the work pieces by entering in the holed surfaces of various work pieces
- Hardened
- Black Coating



Referenz-Nr. Order No.		H1 - H2 (mm)	Spannkraft Clamping Force Kgf	 (g)
1472-02530	14-16-18-20-22	25 - 30	1000	1000
1472-03035		30 - 35	1000	1150
1472-03540		35 - 40	1000	1225
1472-04045		40 - 45	1000	1245
1472-04550		45 - 50	1000	1275

1472

- Gehärtet
- Schwarz beschichtet

1472

- Hardened
- Black Coating

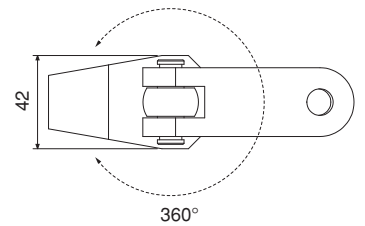
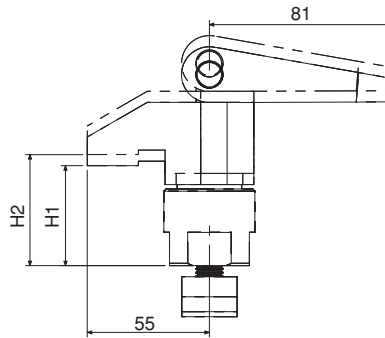
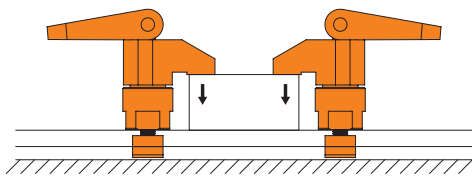

Spannstift

Spring Locating Pins

Referenz-Nr. Order No.	P(N)	D	H (0 -1)	D1	H1	A Bewegung Travel	d (+0.1 0)	 (g)
1473-06001	76	10	11	6	10.7	1	10	4
1473-08001	102	12	13	8	13.9	1.3	12	8
1473-10001	204	16	17	10	16.7	1.6	16	16



1473

Eigenschaft

- Ideal für temporäres Spannen.

Hinweis

- Min. P-Wert für Stiftbewegung
- bis 90 °C

Features

- Ideal for temporary clamping of low-profile workpieces.

Note

- The stated value "P" denotes the minimum force needed to move the pin.
- Heat resistance : 90 °C

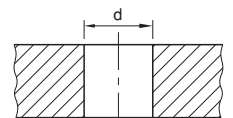
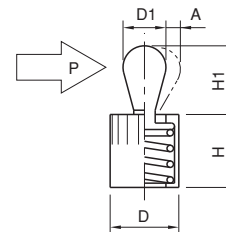

Montage-Bohrung
Installation Hole

Anwendung / How To Use

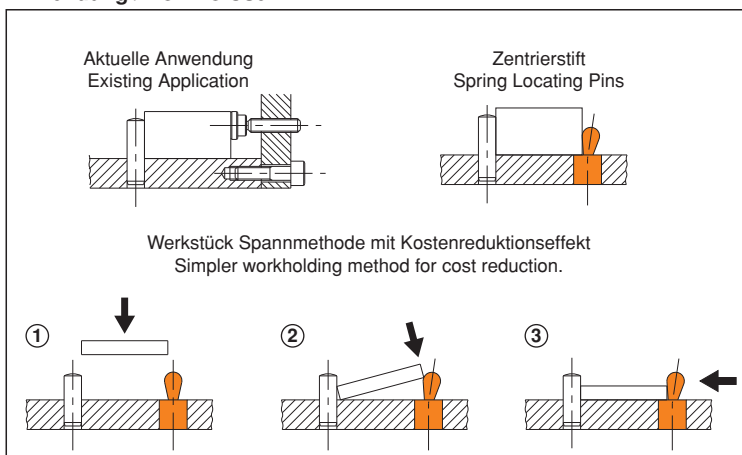

Anwendungsbeispiel / Application Examples

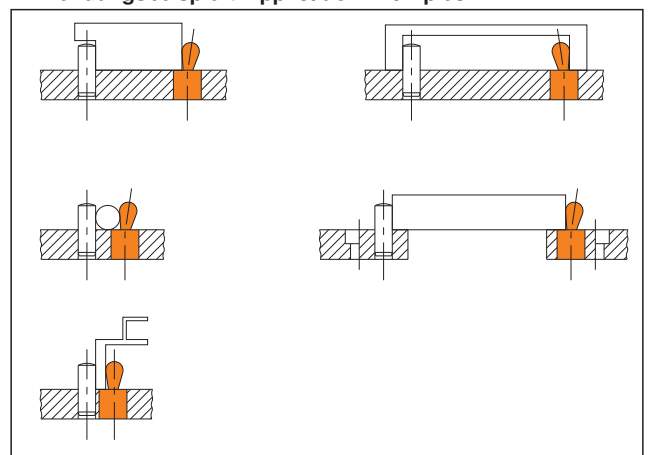

Referenz-Nr. Order No.	S	d (F7)	H2	D1	H (±0.01)	D	M	Dp	R
1474-06000	2	12	10	28	50	65	M8	40	160
1474-08000	2.5	16	12	34	63	80	M10	50	180

Referenz-Nr. Order No.	D2	H1	zulässige Belastung (N) Allowable Operating Load (N)	Spannkraft Clamping Force Kgf	empfohlene Toleranz für Werkstückstärke Recommended Workpiece Thickness Tolerance	 (kg)
1474-06000	26	36	600	600	±0.5	1.2
1474-08000	28	45	600	800	±0.8	2.2

1474

- Schwarz beschichtet

1474

- Black coated

Hinweis 

- Spannbolzen und Zugschrauben müssen extra bestellt werden.

Note 

- Clamping Pins or Screws must be ordered separately.

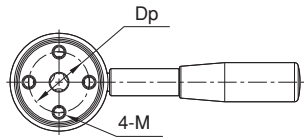
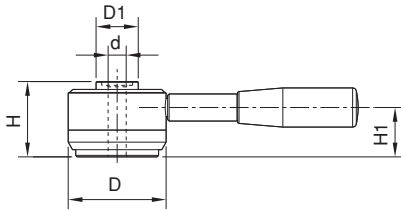

3 mögliche Montagepositionen für den Griff

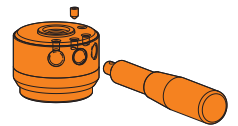

The handle can be removed by loosening the locking screw. To keep the handle mounted permanently, make sure that the locking screw is fully tightened. 3 options of handle mounting position.

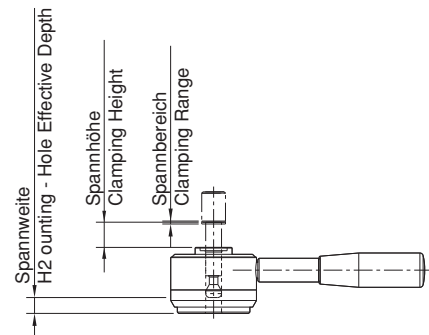
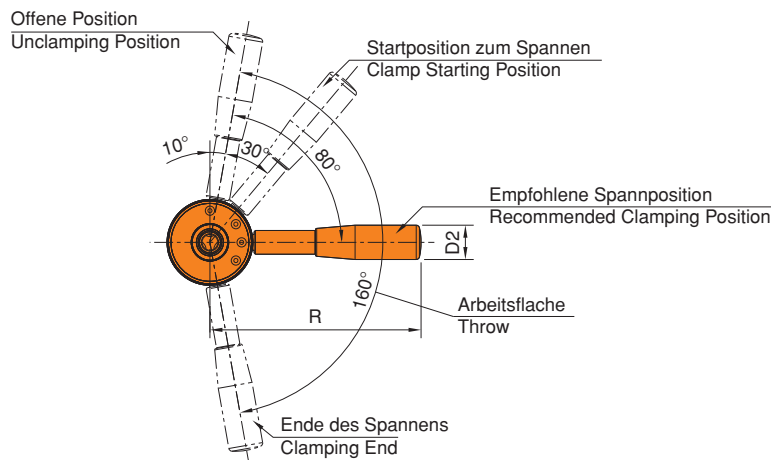

Referenz-Nr. Order No.	D2 (f7)	D1 (f7)	L (By 0.1mm)	D	L2	L1	L3	D3	M	M1	(g)
1475-00012	12	12	0<L<100	18	23	38	21.5	6.5	M8	M8	70 ~ 160
1475-00016	16	16	0<L<100	24	23	38	21.5	6.5	M8	M8	175 ~ 265

1475

- Bolzen**
 • Härte: Induktion
 • Geschliffen

Kopf

- Schwarz beschichtet

1475

- Shank**
 • Hardness: Induction
 • Precision ground

Head

- Black coated



Hinweis

- Fertigung gem. Anforderung

Note

- Custom Clamping Pins are available on request.

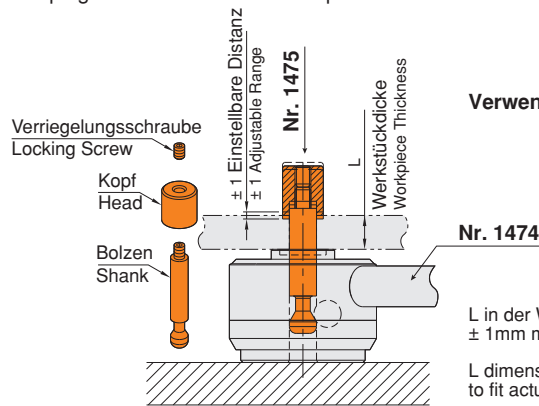
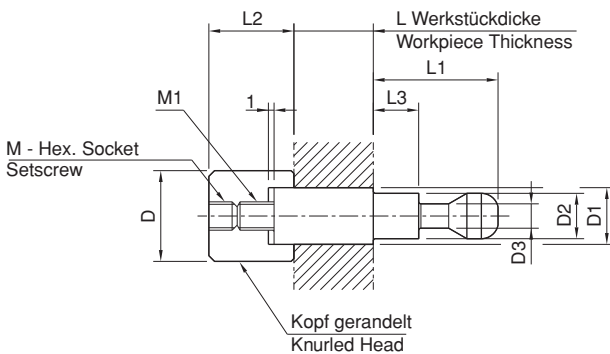

Verwendung / How To Use

L in der Werkstückdicke
 ± 1mm mm einstellbar
 L dimension is adjustable by ± 1mm
 to fit actual workpiece thickness.

Spannschraube

Clamping Screws

Referenz-Nr. Order No.	D1	M	L1	L	D	L2	L3	D2	W	L4	(g)
1476-00012	12	M12	13	38	20	21.5	2	6.5	10	4	40
1476-00016	12	M16	17	38	20	21.5	2	6.5	10	4	55

1476

- Schwarz beschichtet

1476

- Black coated



Hinweis

- Sonderlängen auf Anfrage

Note

- Custom Clamping Screws (different screw thread sizes) are available on request.

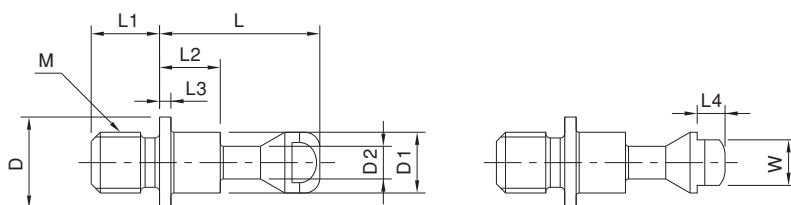

Zugschrauben müssen in den empfohlenen Abstandstoleranzen sein.
 Recommended Spacing Tolerance in Use of Clamping Screws

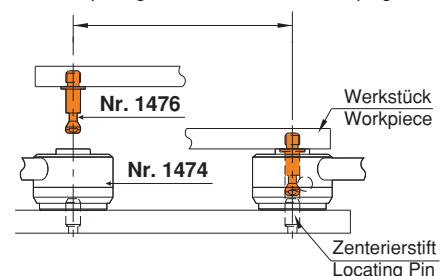

Referenz-Nr. Order No.	Spannkraft Clamping Force Kgf	Tork N-m	 (kg)
1477-00012	1200	40	2.3

1477

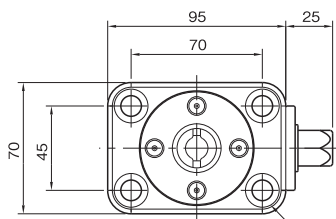

Position Zentrierschraube
For M10 Cap Screws

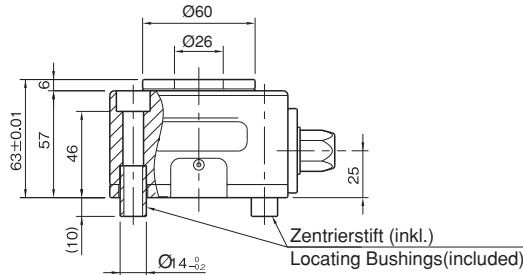

Zentrierstift (inkl.)
Locating Bushings (included)

1. Alle offenen Flächen des Werkstücks können bearbeitet werden.

1. Ideal for 5-Axis Machining
Block Pull Clamps mount under a workpiece making its surfaces to be machined fully open for the cutting tool. This allows completing multiple machining processes at a time.

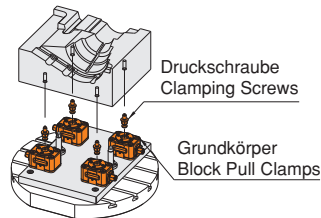

2. Mit Blockziehen ist das Spannen leichter und praktischer als das Konventionelle.

2. Better Workability
Block Pull Clamps allow fastening a workpiece easily, unlike the conventional method of fastening with hexagon head screws from below.

3. Bearbeitung mehrerer unterschiedlicher Werkstücke möglich

3. Actuated Remote-Control Units
If used in conjunction with Power-Tool Actuated Remote-Control Units, Block Pull Clamps can be installed at the best possible position under the workpiece.

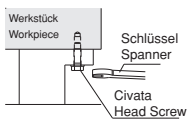

Aktuelle Anwendung
Conventional Method

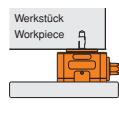

Anwendung mit Druckschraube
Application with pull stud

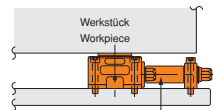

Elektrowerkzeugbetätigte Fernbedieneinheit
Power-Tool Actuated Remote-Control Unit

Verwendung / How To Use

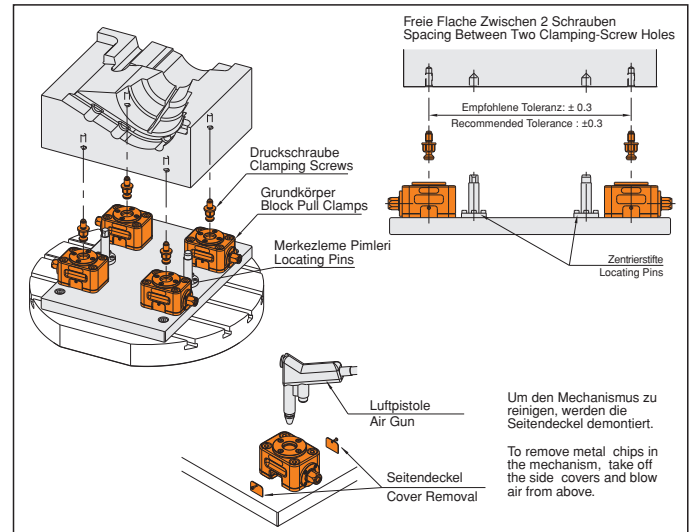

Freie Fläche Zwischen 2 Schrauben
Spacing Between Two Clamping-Screw Holes

Empfohlene Toleranz: ± 0.3
Recommended Tolerance: ± 0.3

Zentrierstifte
Locating Pins

Luftpistole
Air Gun

Seitendeckel
Cover Removal

Um den Mechanismus zu reinigen, werden die Seitendeckel demontiert.
To remove metal chips in the mechanism, take off the side covers and blow air from above.

Spannbolzen
Clamping Screws

Referenz-Nr. Order No.	M	L	 (g)
1478-00012	M12x	21	75
1478-00016	M16	28	98

1478
• Gehärtet
• Schwarz beschichtet

1478
• Hardened
• Black coated

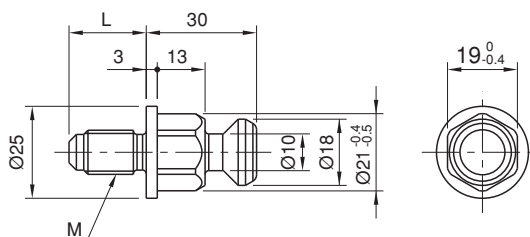

Referenz-Nr. Order No.	Spannhöhe Clamping Height				Spannhub Clamping Stroke	L2	L3	L1	L4	W	L	H4	B	Dp
	Kontakt bearbeitete Fläche Finished Surface Contact		Kontakt grobe Fläche Rough Surface Contact											
	Min.	Max.	Min.	Max.										
1479-0618	21.8 (21.8-24.8)	23.8 (23.8-26.8)	21.4 (21.4-24.4)	23.4 (23.4-26.4)	3	22	6	26	11.5	36	18	6	4.3	27
1479-0823	30.3 (30.3-34.3)	32.3 (32.3-36.3)	31.2 (31.2-35.2)	33.2 (33.2-37.2)	4	30	8	35	15.3	45	23	8	5.3	34
1479-1030	30.5 (30.5-34.5)	37 (37-41)	31.5 (31.5-35.5)	38 (38-42)	4	37	8	45	20.7	65	30	12	8.4	48
1479-1240	34.5 (34.5-39.5)	44 (44-49)	37 (37-42)	46.5 (46.5-51.5)	5	45	8	55	25.4	85	40	15	10.5	64

Referenz-Nr. Order No.	H	D	W1	W2	H2	H1	M1	H3	W3	M	Spannkraft Clamping Force Kgf	zulässiges Drehmoment Allowable Screw Torque (N-m)	 (g)
1479-0618	56.5	18	8	4.3	10	29	M4	22.8	10	M6	230	6	94
1479-0823	73.5	23	10	5.3	14	39	M5	28.5	13	M8	360	10.5	210
1479-1030	91	30	16	8.4	18	48	M8	45.5	17	M10	600	30	515
1479-1240	114	40	20	10.4	22	58	M10	57	19	M12	750	45	1100

1479

Körper

- Gehärtet
- Schwarz beschichtet

Spannspindel

- Schwarz beschichtet

1479

Body

- Hardened
- Black coated

Clamping Spindle

- Black coated

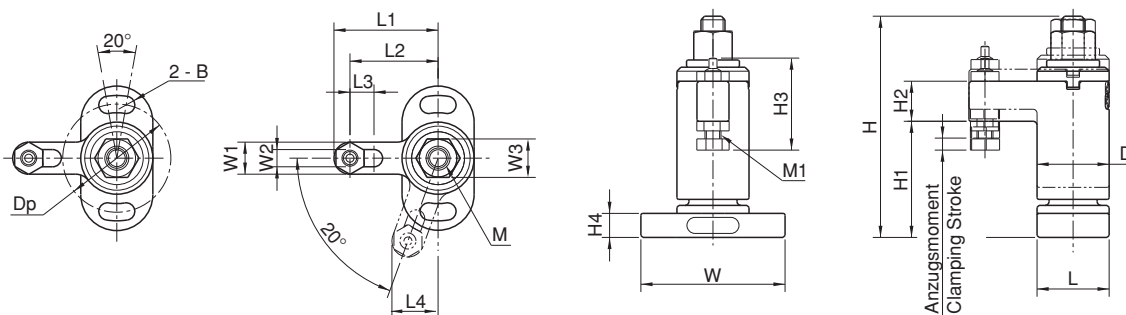

Hinweis

- Spannen mit Drehmomentschlüssel

Note

- Do not use a power tool (impact wrench etc.) to turn the flange nut, for damage prevention.

Verwendung / How To Use

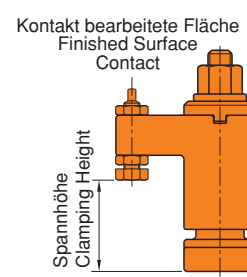
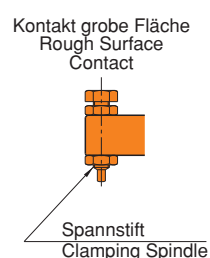
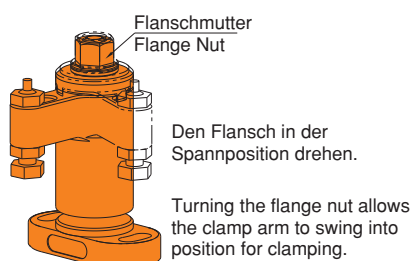

Referenz-Nr. Order No.	H1	S	S1	M	L2	L1	W	L	H4	d	P	H	D	W1	H2	W2	H3
1480-00012	80	10	11	M12	55	66	90	50	15	11	70	139	50	22	30	19	29
1480-00016	95	10	15	M16	65	79	100	60	20	13	80	165	60	28	35	24	35

Referenz-Nr. Order No.	Spannkraft Clamping Force Kgf	Drehmoment Allowable Screw Torque (N - m)	Spannrichtung Clamping Direction	 (kg)
1480-00012	600	28	im Uhrzeigersinn Clockwise	1.6
1480-00016	1000	55	im Uhrzeigersinn Clockwise	2.9



1480

Körper

- Gehärtet
- Schwarz beschichtet

1480

Body

- Hardened
- Black coated

Spannbacke

- Gehärtet
- Schwarz beschichtet

Clamping Arm

- Hardened
- Black coated

Eigenschaften

- Der Klemmarm schwenkt schnell auf die Drehgeschwindigkeit eines Schlagschraubers ein, um schnell zu klemmen.
- Spannt mit kurzer Bewegung

Features

- The clamp arm swings in swift response to the turning speed of an impact wrench, for quick clamping.
- A short clamp-arm travel allows quick clamping.

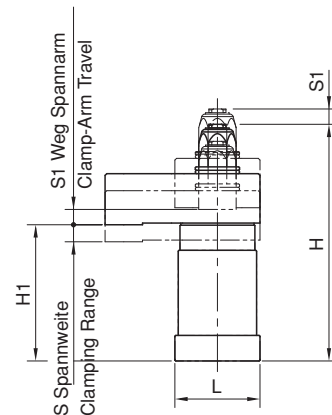
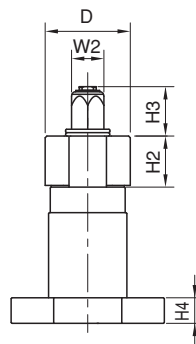
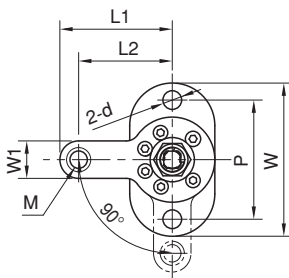

Hinweis

- Spannen unbedingt mit Drehmomentschlüssel

Note

- Do not use applying higher torque than allowable for a long period of time, to avoid damage. Using a torque-settable impact wrench is recommended.

Verwendung / How To Use

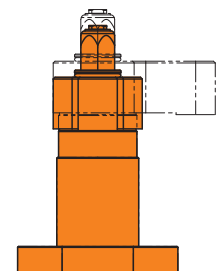
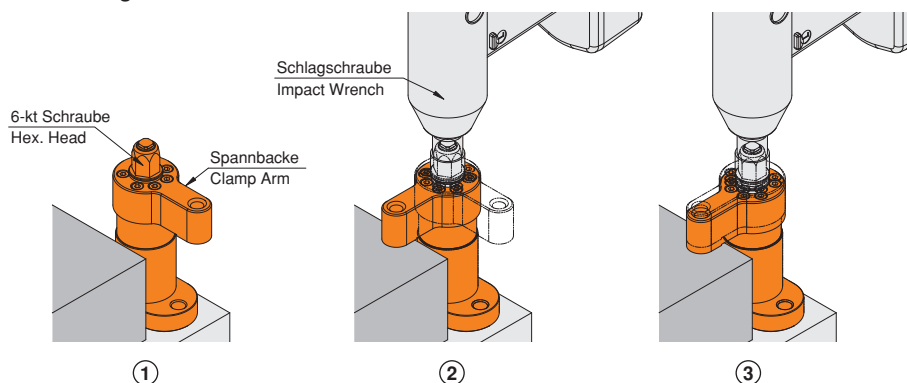

Spannen schwenkbar für Roboterfertigung
For robotized production lines, use Spiral-Acting Swing Clamps.

Referenz-Nr. Order No.	Spannhöhe Clamping Height				Spannhub Clamping Stroke	Vorhubphase Advance Stroke	L2	L3	L1	L4	W	L	H5	B
	Kontakt bearbeitete Fläche Finished Surface Contact		Kontakt grobe Fläche Rough Surface Contact											
	Min.	Max.	Min.	Max.										
1481-0150R	31.3 (30.6-32)	33.3 (32.6-34)	32.2 (31.5-32.9)	34.2 (33.5-34.9)	1.4	1.1	30	8	35	15.3	45	23	8	5.3
1481-0150L														
1481-0200R	32.5 (31.7-33.2)	39 (38.2-39.7)	33.5 (32.7-34.2)	40 (39.2-40.7)	1.5	1.4	37	8	45	20.7	65	30	12	8.4
1481-0200L														
1481-0300R	36.5 (33.5-37.4)	46 (45-46.9)	39 (38-39.9)	48.5 (47.5-49.4)	1.9	1.7	45	8	55	25.4	85	40	15	10.5
1481-0300L														

Referenz-Nr. Order No.	Dp	H	D	W1	W2	H3	H2	M	H4	R	A	H1	zulässige Betriebslast Allowable Operating Load (N)	Spannkraft Clamping Force Kgf	
1481-0150R	34	66	23	10	5.3	14	40	M5	28.5	63	20	61.3	150	180	250
1481-0150L															
1481-0200R	48	82	30	16	8.4	18	50	M8	45.5	80	26	76.5	200	220	570
1481-0200L															
1481-0300R	64	100	40	20	10.4	22	60	M10	57	100	33	93	300	350	1200
1481-0300L															

1481

Körper

- Gehärtet
- Schwarz beschichtet

Spannspindel

- Schwarz beschichtet

1481

Body

- Hardened
- Black coated

Clamping Spindle

- Black coated



Gegen den Uhrzeigersinn
Counterclockwise Clamping

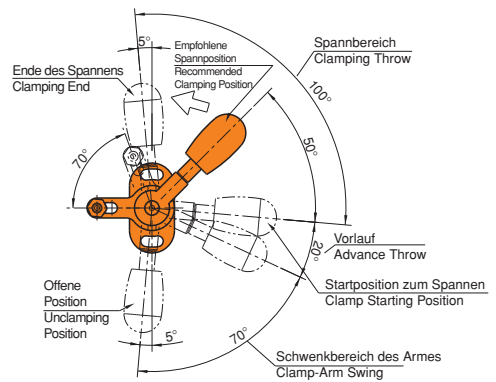

Im Uhrzeigersinn / Clockwise Clamping

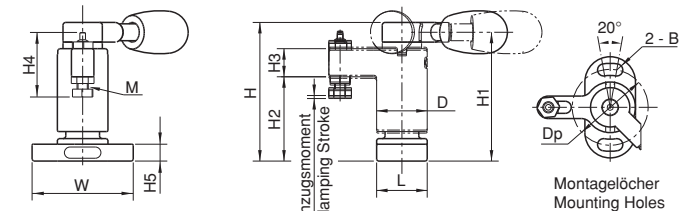
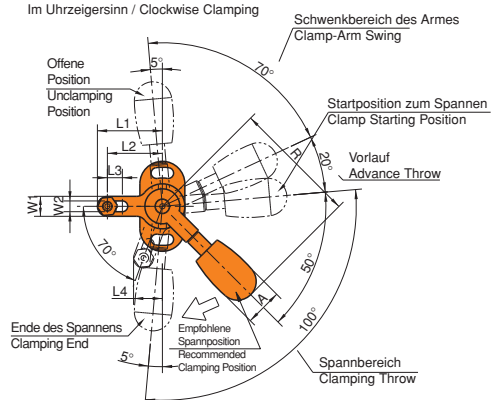

Kontakt grobe Fläche
Rough Surface Contact

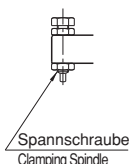

Kontakt bearbeitete Fläche
Finished Surface Contact

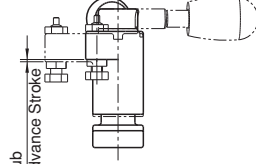
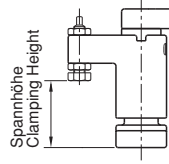

Verwendung / How To Use

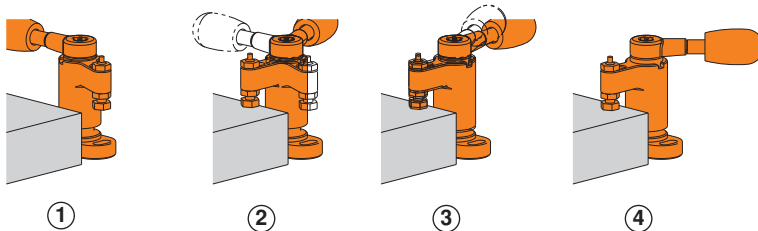

Referenz-Nr. Order No.	Spannhöhe Clamping Height				Spannhub Clamping Stroke	Vorhubphase Advance Stroke	L2	L3	L1	L4	W	L	H5	B
	Kontakt bearbeitete Fläche Finished Surface Contact		Kontakt grobe Fläche Rough Surface Contact											
	Min.	Max.	Min.	Max.										
1482-0150R	31.3 (30.8-31.8)	33.3 (32.8-33.8)	32.2 (31.7-32.7)	34.2 (33.7-34.7)	1	1.5	30	8	35	15.3	45	23	8	5.3
1482-0150L														
1482-0200R	32.5 (31.9-33.1)	39 (38.4-39.6)	33.5 (32.9-34.1)	40 (39.4-40.6)	1.2	1.8	37	8	45	20.7	65	30	12	8.4
1482-0200L														
1482-0300R	36.5 (35.7-37.2)	46 (45.2-46.7)	39 (38.2-39.7)	48.5 (47.7-39.2)	1.5	2.3	45	8	55	25.4	85	40	15	10.5
1482-0300L														

Referenz-Nr. Order No.	Dp	H	D	W1	W2	H3	H2	M	H4	R	A	H1	zulässige Betriebslast Allowable Operating Load (N)	Spannkraft Clamping Force Kgf	
1482-0150R	34	131	23	10	5.3	14	40	M5	28.5	63	19	68	150	150	272
1482-0150L															
1482-0200R	48	167	30	16	8.4	18	50	M8	45.5	80	24	87	200	210	625
1482-0200L															
1482-0300R	64	207	40	20	10.4	22	60	M10	57	100	30	107	300	280	1340
1482-0300L															

1482

Körper

- Gehärtet
- Schwarz beschichtet

1482

Body

- Hardened
- Black coated

Spannspindel

- Schwarz beschichtet

Clamping Spindle

- Black coated

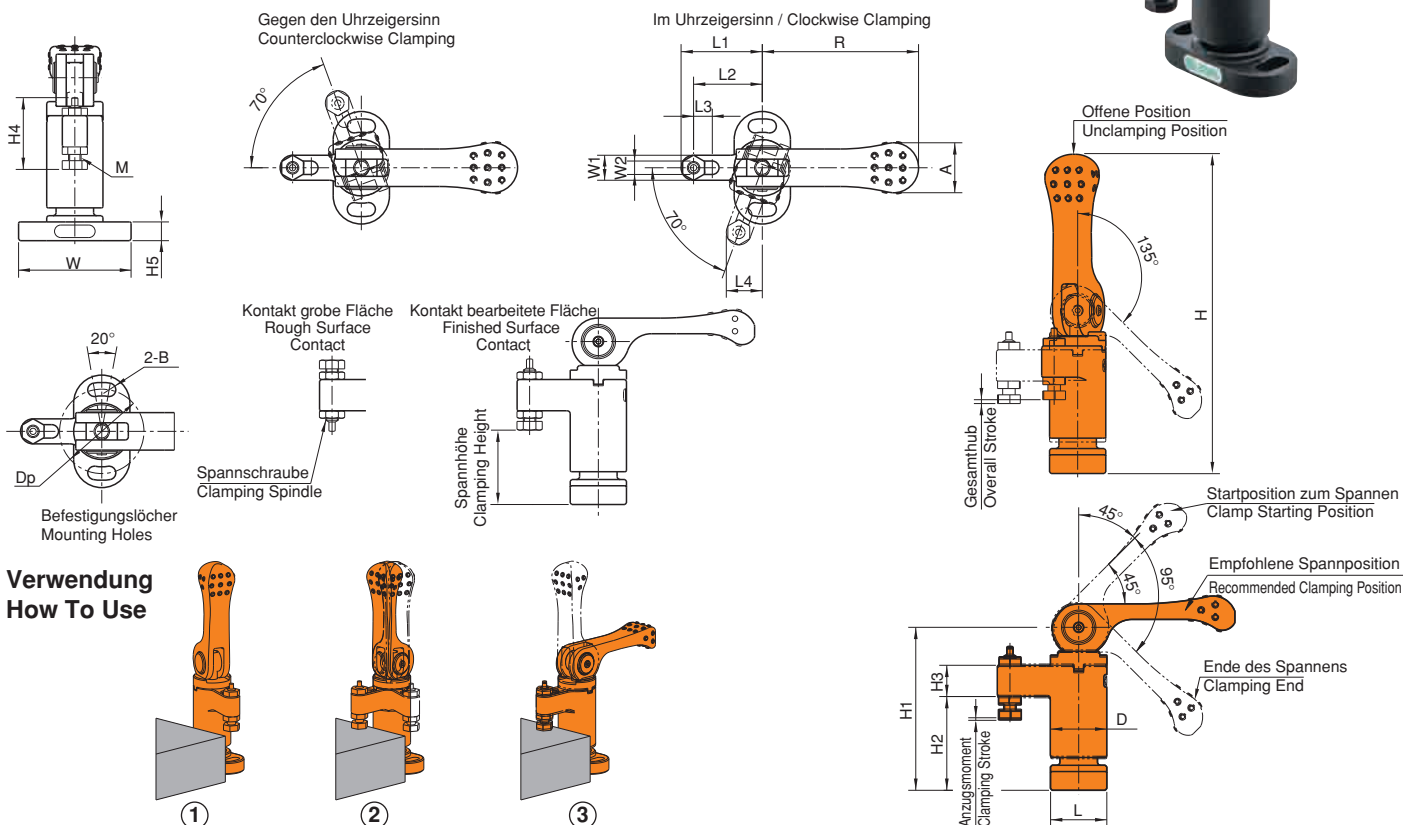

Verwendung How To Use

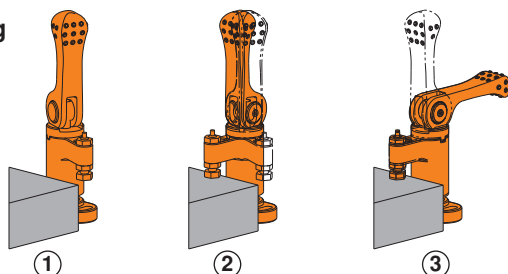

Referenz-Nr. Order No.	Spannhöhe Clamping Height				Spannhub Clamping Stroke	L2	L5	W	L	H4	d	P	H	L1	L3	W1
	Kontakt bearbeitete Fläche Finished Surface Contact		Kontakt grobe Fläche Rough Surface Contact													
	Min.	Max.	Min.	Max.												
1483-03240	32 (32-29.5)	40 (40-37.5)	35 (35-32.5)	43 (43-40.5)	2.5	20	11	42	18	8	5.5	32	81	25.5	25	26
1483-03748	37 (37-33.5)	48 (48-44.5)	42 (42-38.5)	53 (53-49.5)	3.5	25	14	52	22	10	6.6	40	100	32	31	32

Referenz-Nr. Order No.	W2	H2	H1	M	H3	R	H5	L4	verstellbarer Griff Adjustable Handles	zulässige Betriebslast (N) Allowable Operating Load (N)	Spannkraft Clamping Force Kgf	Spannmechanismus Clamping Mechanism	
1483-03240	22	10	45	M6	24	40	47	16	FKF8-BR	170	240	Schraube Screw	242
1483-03748	28	12	55	M8	30.5	65	63	20	FKF8-BR	210	420	Schraube Screw	490

1483

Körper

- Gehärtet
- Schwarz beschichtet

1483

Body

- Hardened
- Black coated

Spannspindel

- Schwarz beschichtet

Clamping Spindle

- Black coated

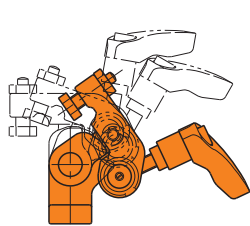
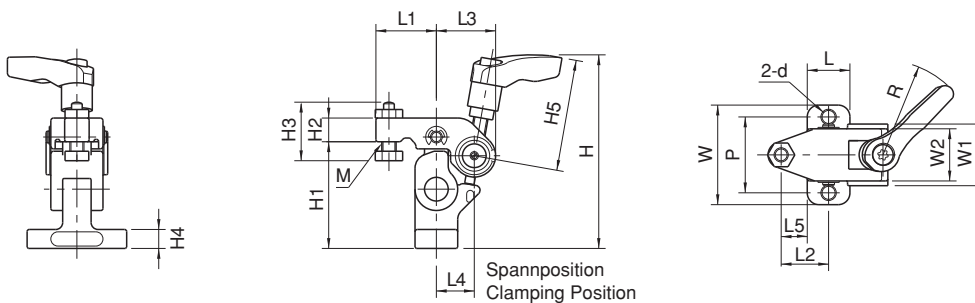

Geöffnete Stellung
Unclamped

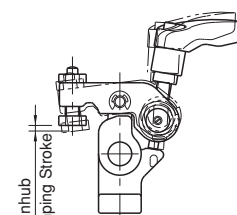
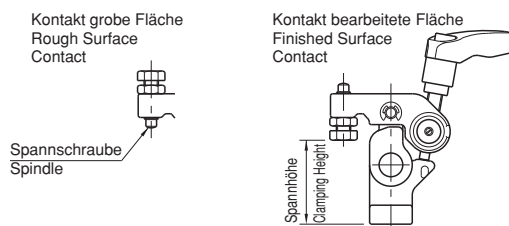

Einstellbarer Bereich
Clamping Throw

Verwendung / How To Use

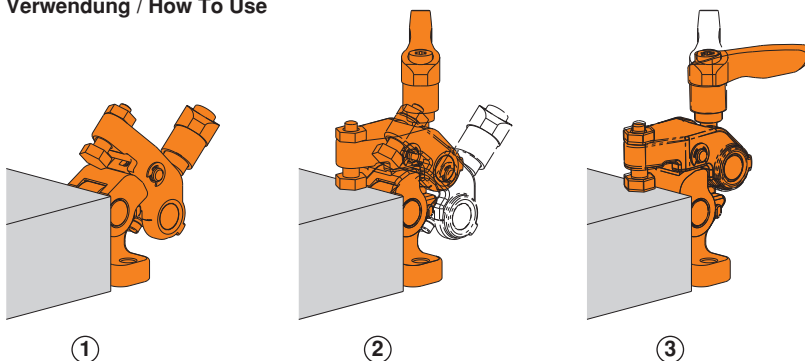

①

②

③

Referenz-Nr. Order No.	A	B	C	D	E	F	G (g6)	H	J (h6)	K	L	M	N	P (±0.02)	Q	R
1484-06501	65	57	10	47	39	70	28	12	6	5	19	M6	42	26	32	25
1484-09001	90	72	15	57	46	95	42	14	8	7	23	M8	60	36	38	28

Referenz-Nr. Order No.	T	U	V	W	Z	Spannkraft Clamping Force Kgf	Drehmoment Allowable Screw Torque (N - m)	 (kg)
1484-06501	15	18	4	M4	M8	400	60	1.1
1484-09001	17	22	6	M5	M10	600	100	2.6

1484

Technische Daten

- Teile-Wiederholgenauigkeit: ±0.03
- Spannbacken Wiederholgenauigkeit : ±0.02

Hinweis

- Ohne Werkstück nicht spannen.
- Bearbeiten nur so weit es zulässig ist.

Inhalt

- 1 St. Sicherungsring
- 1 St. Diamantnadel
- 1 St. Inbusmutter

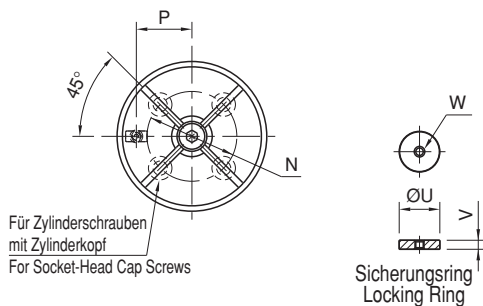

1484

Technical Data

- Part locating repeatability: ±0.03
- Jaw locating repeatability: ±0.02

Notes

- Never tighten the locking screw without a part mounted, to avoid damage and deformation
- Do not machine the jaw deeper than allowed.

Included

- 1 of locking ring
- 1 of diamond pin
- 1 of socket-head cap screw

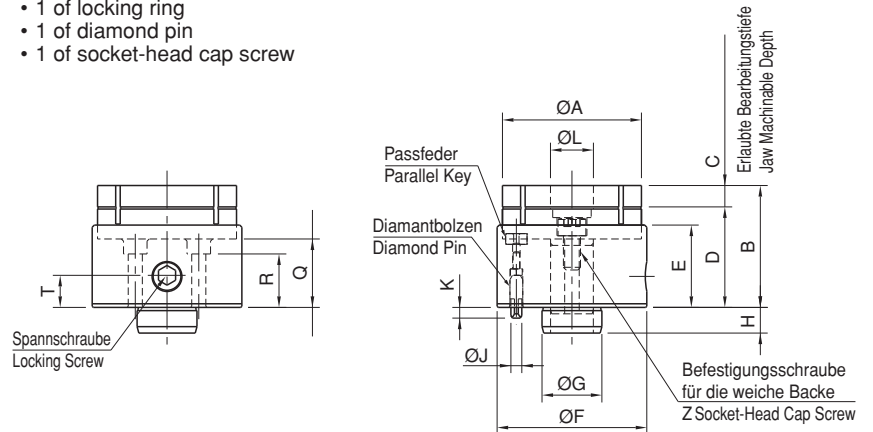

Spannbacken

Jaws

Referenz-Nr. Order No.	A	B	C	D	E	F	G	H	J	K	 (g)
1485-06501	65	25	10	15	19	28	18	4	M4	M10	170
1485-09001	90	34	15	19	23	39	22	6	M5	M12	470

1485

- Material: A7075

1485

- Material: A7075

Eigenschaft / Feature

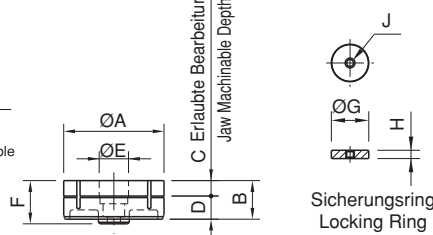
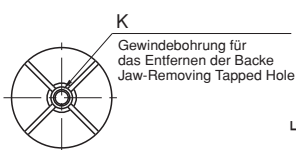
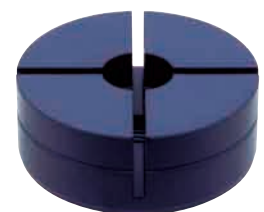
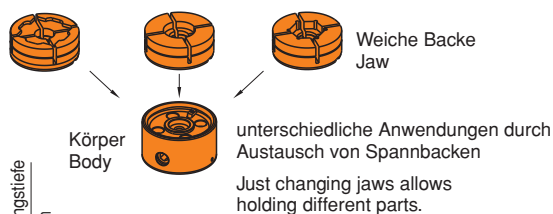

Entfernen der Backe / How To Remove Jaw

Demontage evtl. mittels Schraube

When it is hard to remove the jaw by hand, screw a bolt into the jaw-removing tapped hole to push it against the body, for easier removal.

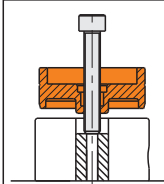

Referenz-Nr. Order No.	d	h (±0.01)	d1 (g6)	h1	M	h2	dp	p (±0.02)	w	h3	M1	Drehmoment Allowable Screw Torque (N - m)	 (kg)
1486-CP125.06501	65	25	28	12	M6	27	42	22	8	12	M8x1.25	15	0.8
1486-CP125.09001	90	30	42	14	M8	30	60	30	8	14	M10x1.5	25	1.7
1486-CP125.12001	120	35	55	18	M10	33	80	43	10	16	M10x1.5	40	3.5
1486-CP125.16001	160	40	63	24	M12	36	110	60	10	18	M12x1.75	40	7.1

geeignete Spannbacken / Proper Jaws

äußere Formen spannen / For External Form Holding			innere Formen spannen / For Internal Form Holding		
Referenz-Nr. Order No.	Spannkraft Clamping Force Kgf	Klemmmoment Clamping Torque	Referenz-Nr. Order No.	Spannkraft Clamping Force Kgf	Klemmmoment Clamping Torque
1486-CP126.06501	4.5	Ø 0.3	1486-CP127.06501	4.5	Ø 0.3
1486-CP126.09001	7		1486-CP127.09001	7	
1486-CP126.12001	10		1486-CP127.12001	10	
1486-CP126.16001	12		1486-CP127.16001	10	



1486

- Nickelbeschichtung
- Werkstück Wiederholgenauigkeit ±0.03
- Weiche Backe Wiederholgenauigkeit ±0.03

1486

- Nickel Coating
- Part locating repeatability: ±0.03
- Jaw locating repeatability: ±0.03

Hinweis

die Backen muss separat bestellt werden.

Note

Jaws must be ordered separately.

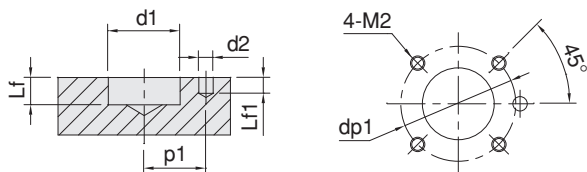
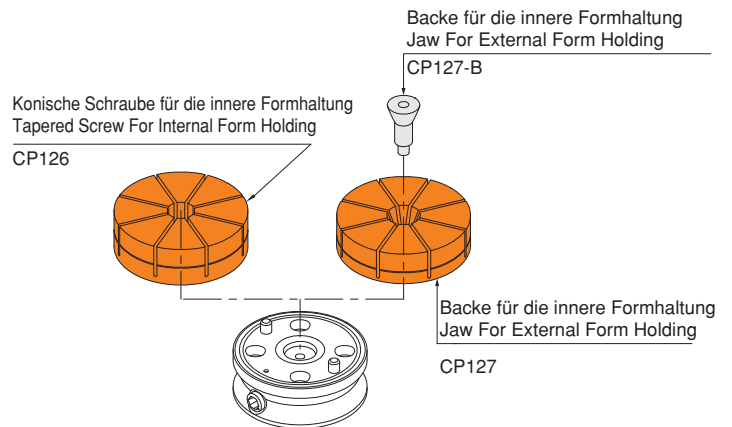
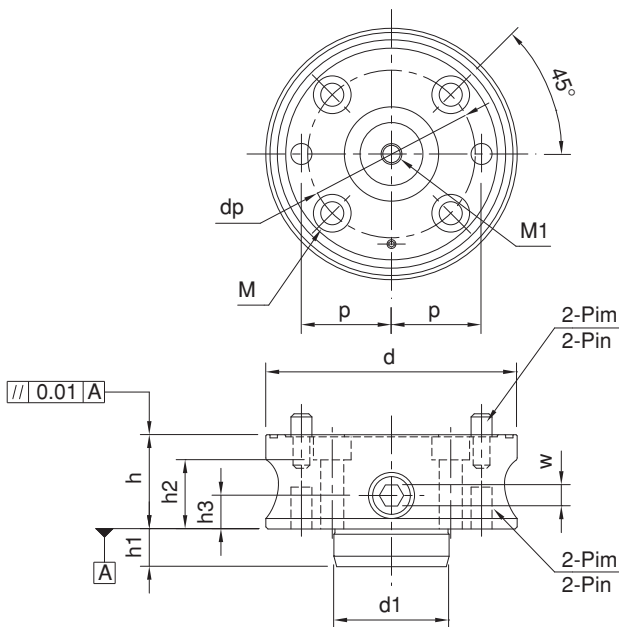

Referenz-Nr. Order No.	d1 (H7)	Lf	d2 (G7)	Lf1	p1 (±0.02)	M2	dp1
1486-CP125.06501	28	13	6	6	22	M 6x1	42
1486-CP125.09001	42	15	8	8	30	M 8x1.25	60
1486-CP125.12001	55	19	10	11	43	M10x1.5	80
1486-CP125.16001	63	25	12	13	60	M12x1.75	110

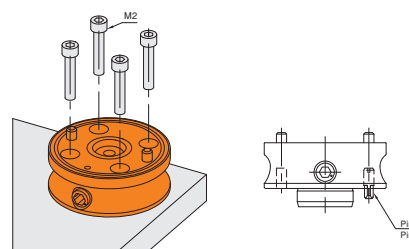

Stiftdurchmesser Pin Dimensions

Referenz-Nr. Order No.	Durchmesser Diameter
1486-CP125.06501	Ø 6h6
1486-CP125.09001	Ø 8h6
1486-CP125.12001	Ø 10h6
1486-CP125.16001	Ø 12h6

Referenz-Nr. Order No.	D	d	h1	h2	M	h	M	d1	t	 (g)
1486-CP126.06501	65	21	25	10	M8x20	29	M5	20	4	200
1486-CP126.09001	90	25	35	15	M10x20	40	M6	24	5	500
1486-CP126.12001	120	25	40	20	M10x25	46	M6	24	5	1100
1486-CP126.16001	160	29	45	25	M12x25	52	M8	28	6	2200



- 1486**
- Material: Aluminium A7075
 - Blau Beschichtet
 - Klemmmoment 0.15mm

- 1486**
- Material: Aluminum A7075
 - Blue coating
 - Clamping Torque 0.15mm

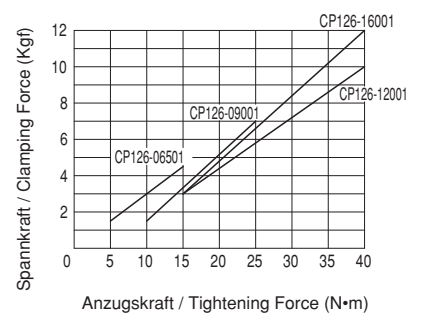
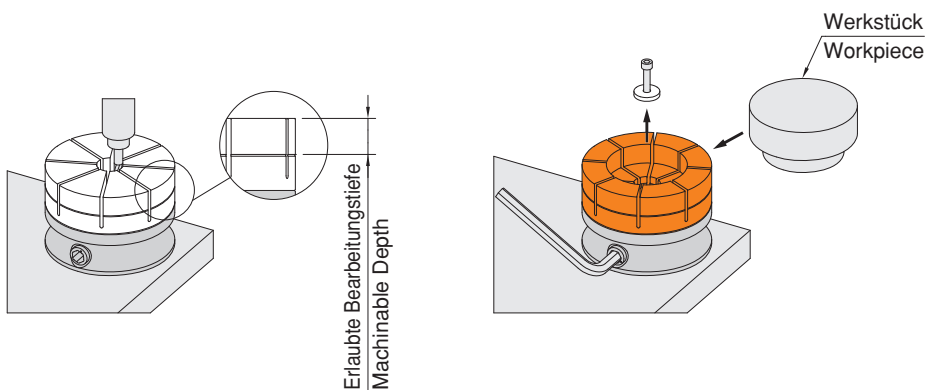
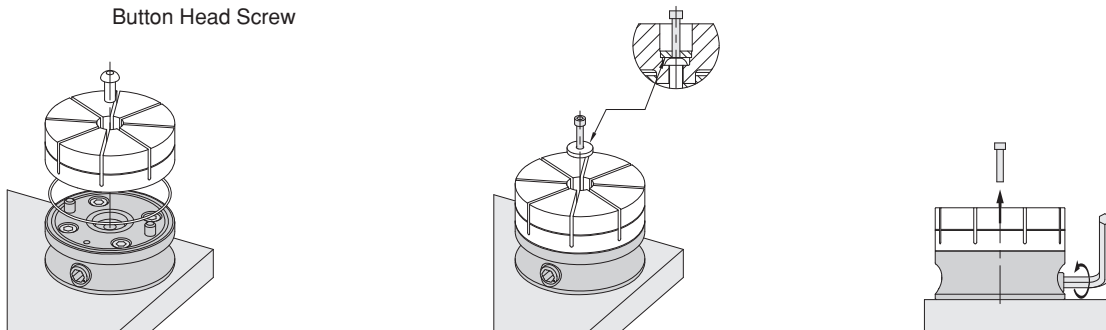
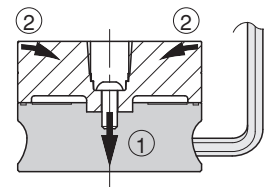
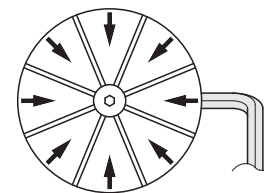
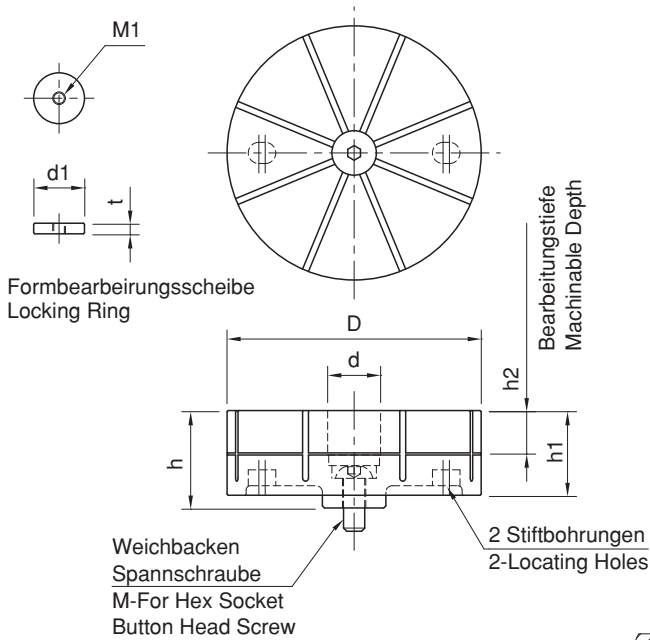

Referenz-Nr. Order No.	D	h1	h2	h	(g)
1486-CP127.06501	65	25	10	28.5	200
1486-CP127.09001	90	30	15	34.5	400
1486-CP127.12001	120	35	20	40.5	900
1486-CP127.16001	160	40	25	46.5	1900



1486

- Material: Aluminium A7075
- SilberBeschichtet
- Klemmoment 0.15mm

1486

- Material: Aluminum A7075
- Silver coating
- Clamping Torque 0.15mm

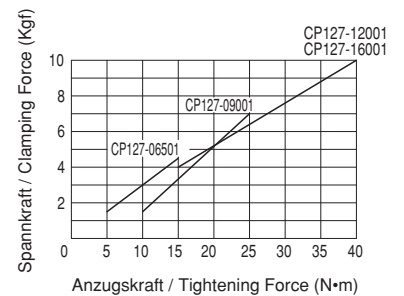
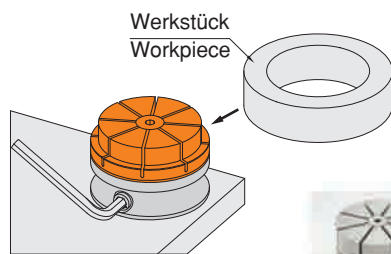
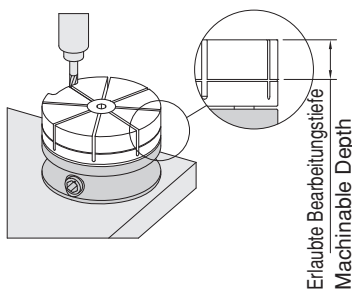
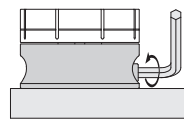
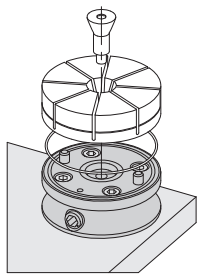
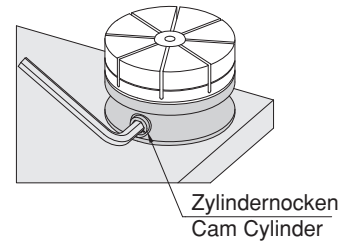
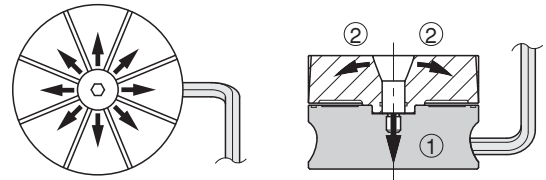
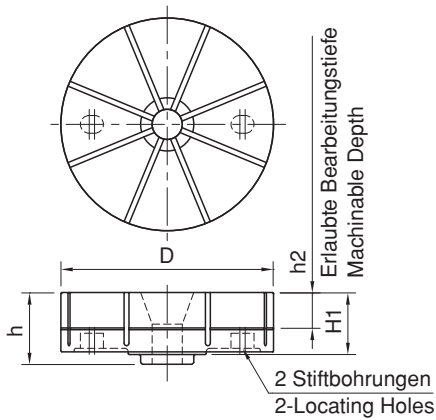

Schraube für innere Spannbacken Außendurchmesser

Referenz-Nr. Order No.	D	L	M	L1	d1	w	(g)
1486-CP127.06501B	22.5	29	M8	10	13.2	6	50
1486-CP127.09001B	27	35	M10	11	16	8	80
1486-CP127.12001B	29	41	M10	13	16	8	100
1486-CP127.16001B	33	47	M12	14	18	10	150

1486

- SilberBeschichtet

1486

- Silver coating

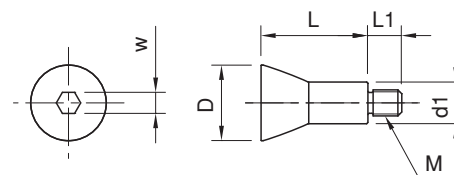

Referenz-Nr. Order No.	D		H	H1	R	H2		L1	geeignete Schrauben Proper Cap Screws	Spannkraft Clamping Force Kgf	 (g)
	min.	max.				min.	max.				
1487-04001	19.5	24	9	2.5	R9.5	8	2.6	9.4	M4	200	20
1487-06001	23.5	29	13	4	R11.5	11.5	5	13	M6	500	45
1487-08001	28.5	36	17	5.5	R14	15	6	19	M8	900	90

1487

- Gehärtet
- Schwarz beschichtet

1487

- Hardened
- Black coated



Eigenschaften

- Spannen im Innendurchmesser
- Konische Passfeder ermöglicht kräftiges Spannen.
- Einsatz in Gusslöchern und groben Löchern ist möglich durch langen Hub.

Feature

- These clamps hold the inside diameter of the workpiece.
- The wedge construction allows powerfully clamping the workpiece.
- Long clamping stroke is ideal for holding as-cast or roughly-finished holes.

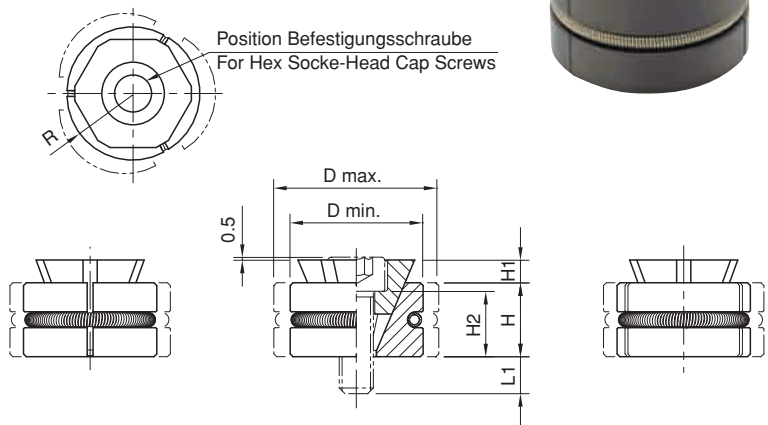

Verwendung / How To Use

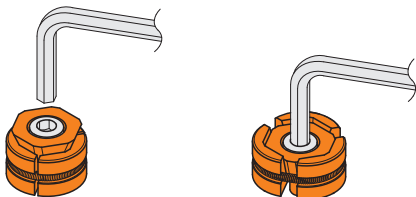

Beim Werkstückspannen Kontakt in Linienform. Bei bearbeiteten Löchern nicht empfehlenswert, da sonst im Loch Deformationen entstehen können.

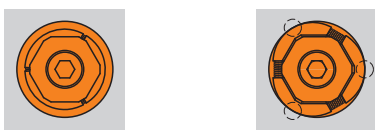

Geöffnet
Unclamping Mode

Geschlossen
Clamping Mode

The clamp makes a line contact with the workpiece at the clamping mode. This contact can mar the surface of the workpiece depending on its materials, and using these clamps for accurately finished holes is not recommended.

Hinweis

- Richtige Zentrierung gem. Zeichnung unten

Notes

- For accurate locating, use these clamps with a locator as shown below.

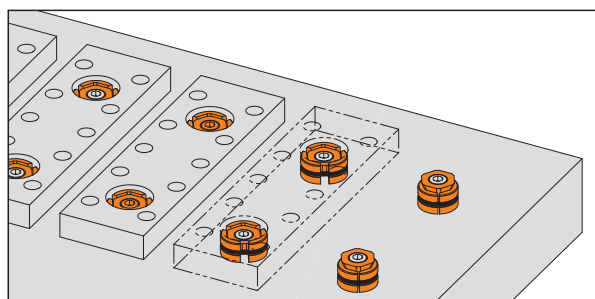
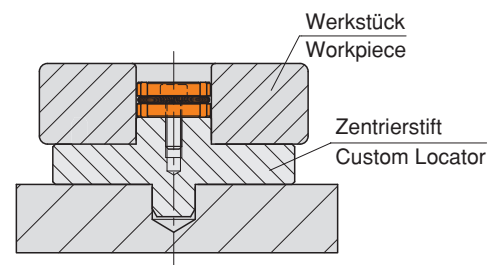

Beispiel Spannen 2-fach.
Example of application where two I.D. Holding Clamps are used.

Referenz-Nr. Order No.	d		h		h1	M	L1	W	Spannkraft Clamping Force kgf	Drehmoment Allowable Screw Torque (N · m)	 (g)
	min.	max.	d min.	d max.							
1487-04001A	8	10.3	5.5	4.6	0.9	M4x12	7.3	2.5	900	2.1	3
1487-05001A	10	12.3	6.4	5.6	1.1	M5x15	9.1	3.	1500	4.3	5
1487-06001A	12	16.3	8.6	7	1.3	M6x18	11.2	4.	2100	7.3	9
1487-08001A	16	22	11.5	9.4	1.6	M8x25	16.2	5	4000	18	22
1487-04001B	8	10.3	5.5	4.6	5.1	M4x12	7.1	3	1500	2.7	4
1487-05001B	10	12.3	6.4	5.6	6.2	M5x15	9	4	2500	5.4	7
1487-06001B	12	16.3	8.6	7	7.9	M6x18	10.6	5	5000	9.1	11
1487-08001B	16	22	11.5	9.4	10.4	M8x25	15.4	6	9000	25	28



1487

- Gehärtet
- Schwarz beschichtet

1487

- Hardened
- Black Coated

Eigenschaften

- Diese Spannelemente greifen das Werkstück von innen.
- Nockkonstruktion ermöglicht starkes Spannen.
- Der langspannhub ist ideal zum halten der Gussteile oder grob fertige löcher.

Features

- These clamps hold the inside diameter of the workpiece.
- The wedge construction allows powerfully clamping in the workpiece.
- Long clamping stroke is ideal for holding as-cast or roughly-finished holes.

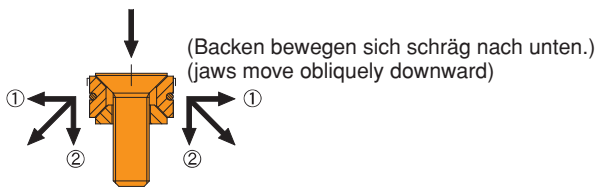

- ① Horizontaler Druck gegen Wertstück
Horizontal pressure against workpiece
- ② Vertikaler Druck verhindert, dass sich das Werkstück hebt.
Vertical pressure preventing workpiece lift

Verwendung / How To Use

Hinweis

- Klemm das Werkstück auf die Spannmodus der Verbindungsleitung .
Es ist nicht diese Klemme zu verwenden, für die Fertigbohrungen empfohlen.

Notes

- The clamp makes a line contact with the workpiece at the clamping mode.
This contact can mark the surface of the workpiece depending on its materials
and using these clamps for accurately finished holes is not recommended.

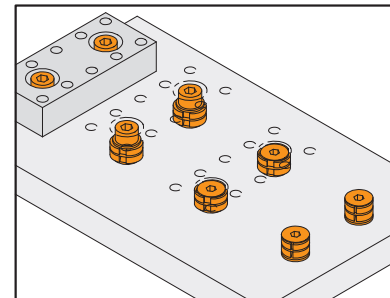
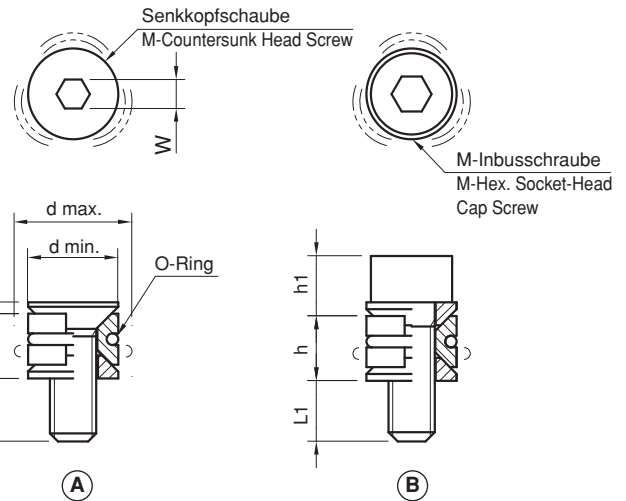
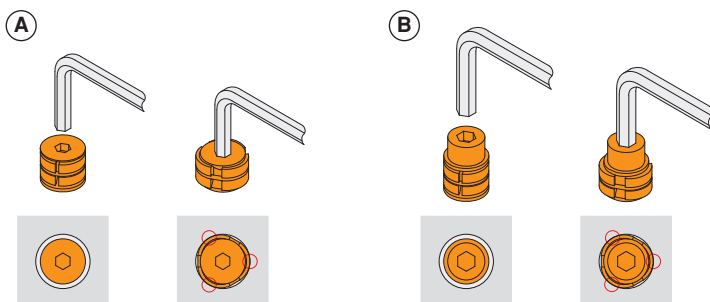

Beispiel: 2 kompakte Anwendungen für Spannen im Loch

Example of applications where two compact ID holding clamps are used.

Hinweis

- Für eine genaue Ortung, verwenden Sie diese Klemmen mit einem Locator, wie unten gezeigt.

Notes

- For accurate locating, use these clamps with a locator as shown below.

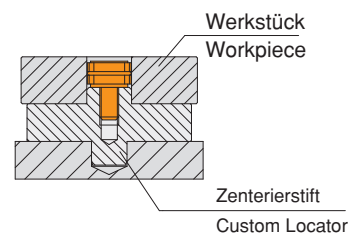

Referenz-Nr. Order No.	Durchmesser verstellbarer Werkstückdurchmesser Adaptable Workpiece Dia.	d1	d2	h2	h1	d (⁰ / _{0.05})	h	M	L	w	M1	L1	dp	Spannkraft Clamping Force Kgf	Drehmoment Allowable Screw Torque (N - m)	zulässige Dehnung Recommended Range of Expansion of Dia	zulässiger Öffnungsdurchmesser Allowable Expansion of Dia	(g)
1488-00004	Ø7.1-Ø12.4	12.4	7.1	15	16	29.72	21.8	M4	7.2	3	M3	6	21	420	5	0.07	0.13	45
1488-00006	Ø12.2-Ø14.2	14.2	12.2	15	19	31.5	24.9	M6	11.2	5	M3	6	23.1	440	17	0.08	0.23	60
1488-00008	Ø13.5-Ø20	20	13.5	15	19	37.5	24.9	M8	13.2	6	M3	6	29	1100	34	0.08	0.30	95
1488-00010	Ø18-Ø27	27	18	17.5	22.2	50	28.6	M10	16.3	8	M4	7	39.4	2000	60	0.08	0.35	190
1488-00012	Ø23-Ø35.3	35.3	23	20.6	25.4	56	31.8	M12	20.3	10	M4	7	45.5	2600	150	0.08	0.35	300
1488-0016A	Ø29.3-Ø42	42	29.3	27	31.8	69.5	39.6	M16	21.4	14	M5	13	55.9	4400	280	0.08	0.35	570
1488-0016B	Ø29.3-Ø51.5	51.5	29.3	27	31.8	75.5	39.6	M16	21.4	14	M5	13	63.9	4400	280	0.08	0.35	750
1488-0016C	Ø29.3-Ø77.7	77.7	29.3	32.3	37.6	107.5	45.5	M16	19.3	14	M6	14	92.6	4400	280	0.15-0.4	0.60	1800
1488-0016D	Ø29.3-Ø103	103	29.3	32.3	37.6	132.9	45.5	M16	19.3	14	M6	14	118.1	4400	280	0.15-0.4	0.60	2900
1488-0016E	Ø29.3-Ø175	175	29.3	32.3	37.6	132.9	45.5	M16	19.3	14	M6	14	118.1	4400	280	0.15-0.4	0.80	6500
1488-0016F	Ø29.3-Ø250.2	250.2	29.3	32.3	37.6	152.4	45.5	M16	19.3	14	M6	14	133.4	2600	170	0.15-0.4	0.80	4800

1488

Körper

- Schwarz beschichtet

Schraube

- Gehärtet

Eigenschaft

- Lochdurchmesser halten
- Durch perfekte Verwendung ist mehrfaches Spannen möglich.
- Spannen auch durch hydraulisches Ziehen möglich.
- Anpassung gem. Werkstück möglich.

Hinweis

- Kanten-/Eckenradius bearbeiteter Werkstücke muss mind. 0,5 mm sein.
- Wenn Kanten-/Eckenradius dem Werkstückloch entspricht, dann Buchse verwenden.

1488

Body

- Black coated

Tapered Screw

- Hardened

Features

- Can hold workpieces on an inside diameter.
- Perfect for multiple-parts holding arrangement.
- Using hydraulic pull cylinders to clamp instead of using hex wrenches allows automation.
- Can be machinable to suit your workpieces.

Notes

- The minimum radius of corners at the machined part should be 0.5mm for clamping small workpieces. To prevent stress concentration on these corners, make the radius as large as possible.
- If the radius will interfere with the bottom of the workpiece bore, we suggest a ring or rest-pads be fixed to the flange.

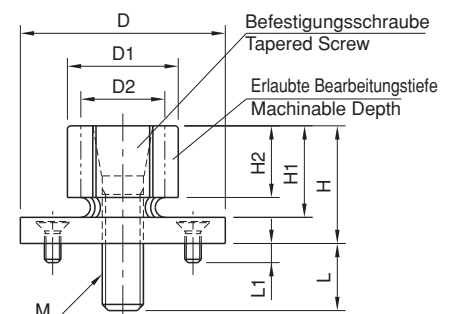
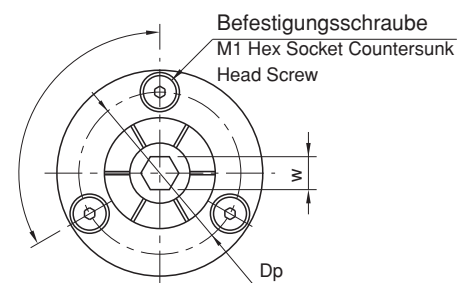
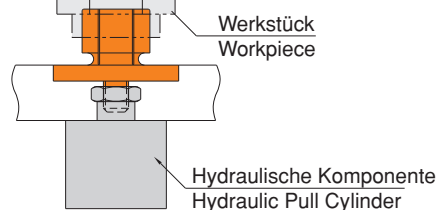
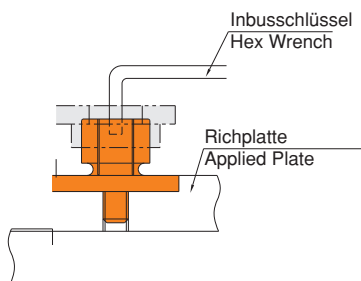

Referenz-Nr. Order No.	Spannkraft Clamping Force (N)	Hubkraft Lifting Force (N)	 (g)
1489-0840R.06	600	100	220
1489-0840R.06N	700	-	215

0840R.06

0840R.06N



1489
• Schwarz beschichtet

1489
• Black coating

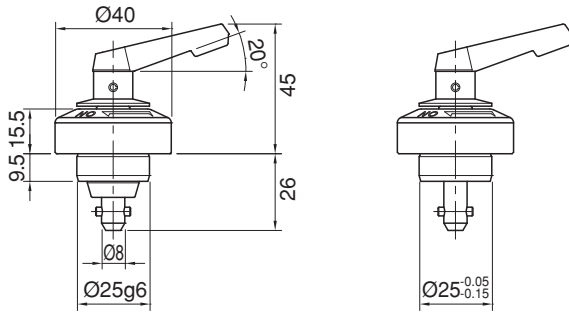
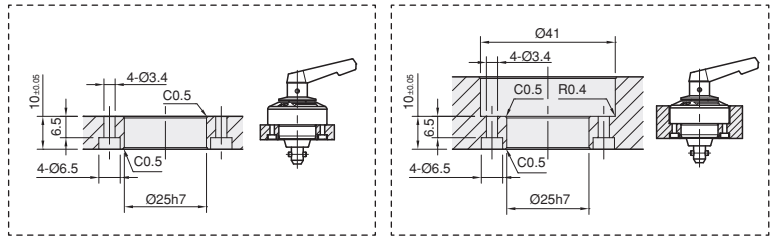
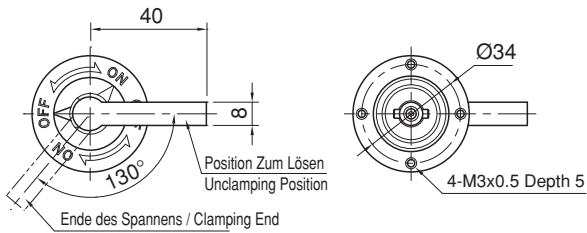

0840R.06

0840R.06N

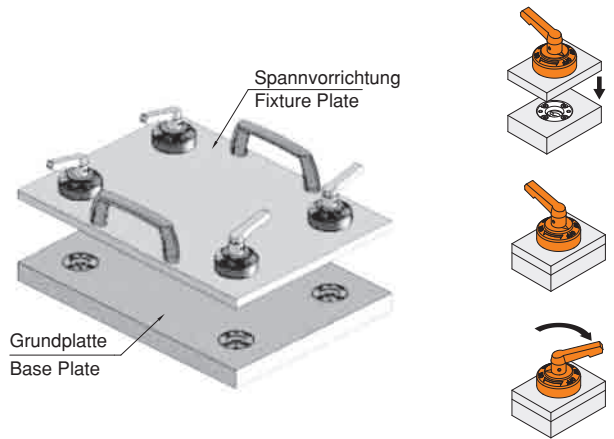

Buchse für Single-Touch Spanner

Single Touch Clamping Bush

Referenz-Nr. Order No.	 (g)
1489-0840R	32

1489
• Schwarz beschichtet

1489
• Black coating

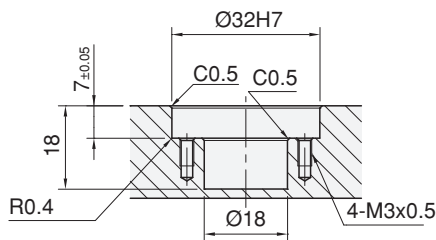
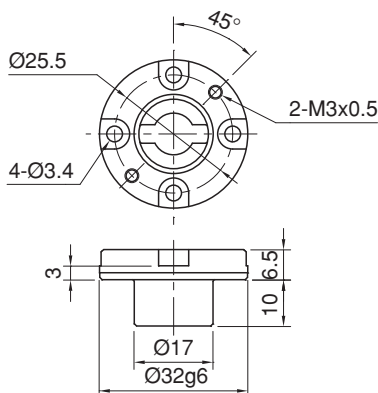

Toleranz / Tolerance ±0.02

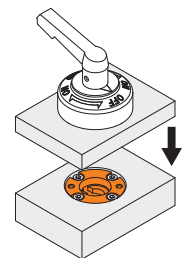
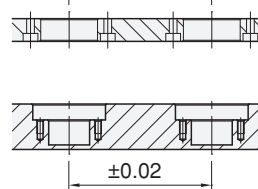

Referenz-Nr. Order No.	D (g6)	H	D1	H1	M	H2	M1	Dp	Hubkraft Lifting Force (N)	 (g)
1489-16032K	32	6.5	20	7	M3	3	M3x0.5	25.5	110	60
1489-25050K	50	10	32	9	M4	5	M4x0.7	42	180	160
1489-38070K	70	15	48	14	M5	9	M5x0.8	60	400	508
1489-56095K	95	22	70	21	M6	15	M6x1.0	84	690	1451



1489

- Die Auftriebskraft ist die Kraft der inneren Feder des Körper die bewegliche Konusbuchsen nach oben zu drücken. (N)
- Wenn die Schrauben nicht in der richtigen Reihenfolge angezogen werden, die Ortung Wiederholbarkeit 0.01 nicht überschreiten
- Wenn die Gesamtbelastung die maximale Ladekapazität überschreitet, die Ortung Wiederholbarkeit 0.01 nicht überschreiten

1489

- The lifting force is the power of the inner spring of the body to push up the movable tapered bushing. (N)
- If the screws are not tightened in the correct order, the locating repeatability may exceed 0.01
- If the total load exceeds the maximum loading capacity, the locating repeatability may exceed 0.01

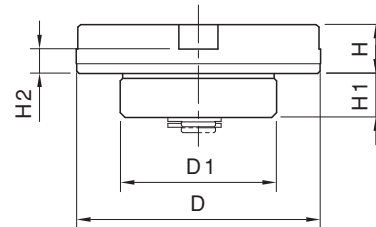
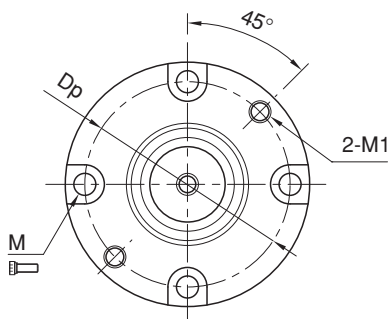

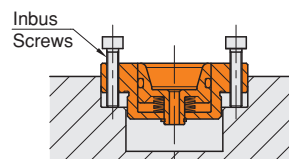
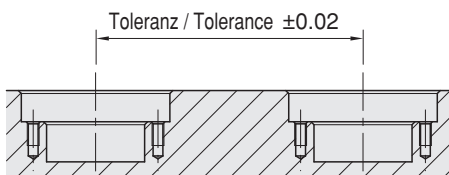
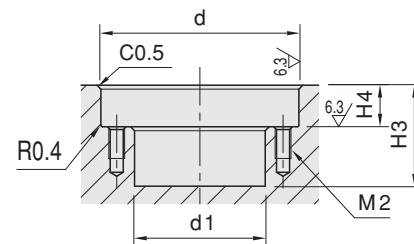

Montagedetails / Mounting Details

Referenz-Nr. Order No.	d (H7)	H4 (±0.05)	d1	H3	M
1489-16032	32	7	21	18	M3x0.5
1489-25050	50	10.5	33	24	M4x0.7
1489-38070	70	15.5	49	35	M5x0.8
1489-56095	95	22.5	71	51	M6x1.0

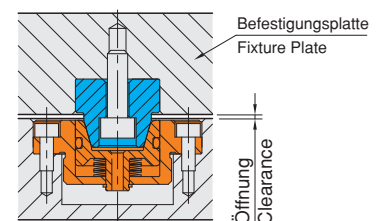
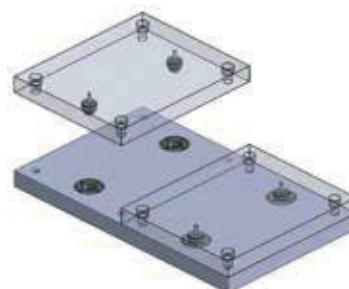
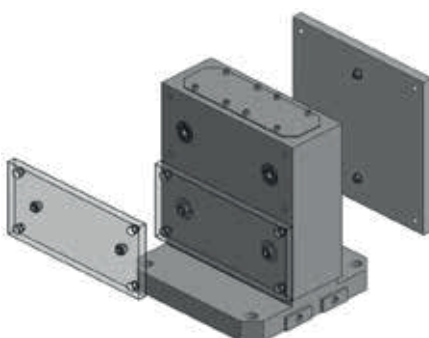

Anwendungsbeispiel / Application Examples



Referenz-Nr. Order No.	D (g6)	H2	H	M	H1	d	 (g)
1489-16032	16	5.5	11.5	M5x0.80	6	8	18
1489-25050	25	10	20	M8x1.25	11.5	11	49
1489-38070	38	15	29.5	M10x1.50	18	14	176
1489-56095	56	22	43.5	M16x2.00	28.5	20	569



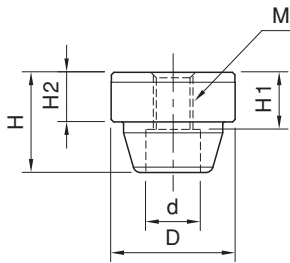

1489

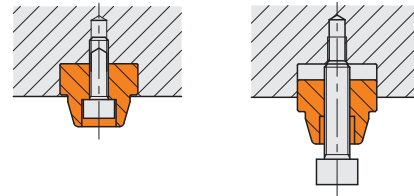
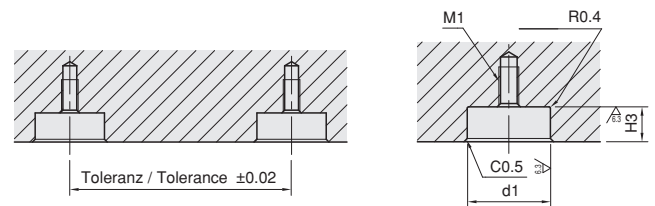

Montagedetails / Mounting Details

Referenz-Nr. Order No.	d1 (H7)	H3 (±0.05)	M1
1489-16032	16	6	M4x0.7
1489-25050	25	10.5	M6x1.00
1489-38070	38	15.5	M8x1.25
1489-56095	56	22.5	M12x1.75



Referenz-Nr. Order No.	D	H	M	W	 (g)
1489-16032P	12	4	M3x0.5	2	3
1489-38070P	19	6	M4x0.7	2.5	5
1489-25050P	29	7	M5x0.8	3	14
1489-56095P	44	8	M6x1.0	4	35

Zentrierschutzkappe

Flex Locator Protecting Covers



1489

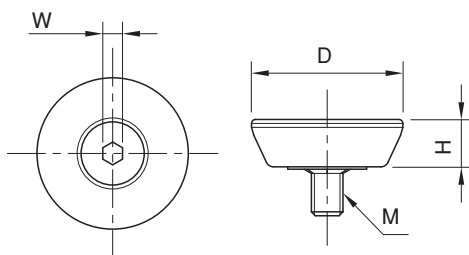

Montagedetails / Mounting Details

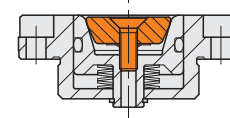



Referenz-Nr. Order No.	D	H	H1	M	Hubkraft Lifting Force (N)	 (g)
1489-12025A	25 ^{+0.028} / _{+0.018}	16	8	M8x1.25	540	46
1489-15032A	32 ^{+0.031} / _{+0.021}	20	9	M10x1.50	600	92
1489-20045A	45 ^{+0.031} / _{+0.021}	26	11	M14x1.50	780	230

1489

- Die Auftriebskraft ist die Kraft der inneren Feder des Körpers die bewegliche Konusbuchsen nach oben zu drücken. (N)
- Wenn die Schrauben nicht in der richtigen Reihenfolge angezogen werden, die Ortung Wiederholbarkeit 0.01 nicht überschreiten
- Wenn die Gesamtbelastung die maximale Ladekapazität überschreitet, die Ortung Wiederholbarkeit 0.01 nicht überschreiten

1489

- The lifting force is the power of the inner spring of the body to push up the movable tapered bushing. (N)
- If the screws are not tightened in the correct order, the locating repeatability may exceed 0.01
- If the total load exceeds the maximum loading capacity, the locating repeatability may exceed 0.01

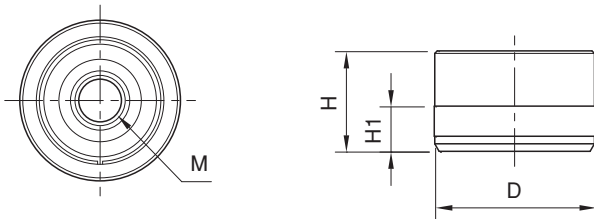

Montagedetails / Mounting Details

Referenz-Nr. Order No.	d (H6)	H2 (±0.05)	d1	H3	M1	M2
1489-12025	25	16.5	25.2	8	M6x1.00	M10x1.50
1489-15032	32	20.5	32.2	11	M8x1.25	M12x1.75
1489-20045	45	26.5	45.2	15	M12x1.75	M16x2.00

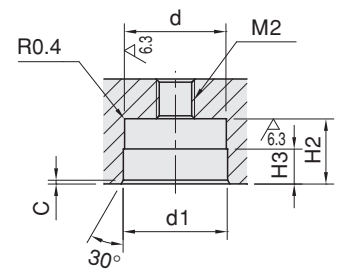
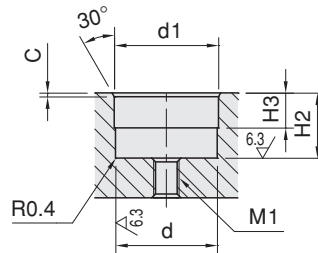
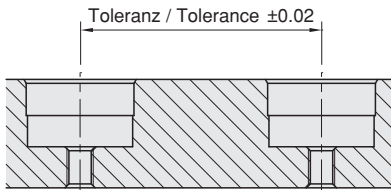
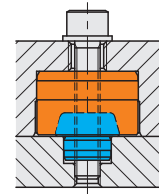
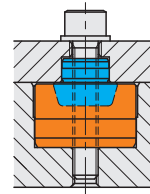

Anwendungsbeispiel / Application Examples

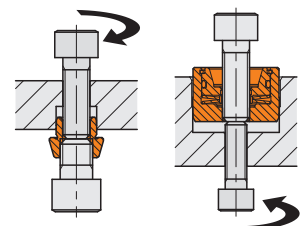
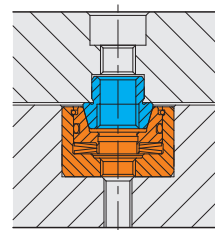
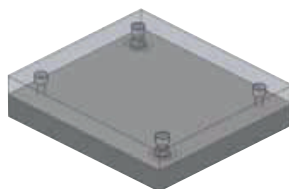
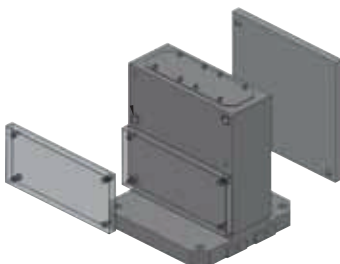



Referenz-Nr. Order No.	D1 (p6)	H1	D	H	M	d	
1489-12025	12	4.5	15	10	M10x1.50	8.5	6
1489-15032	15	7.5	20	15	M12x1.75	10.2	16
1489-20045	20	10	30	20	M16x2.00	14	47

1489

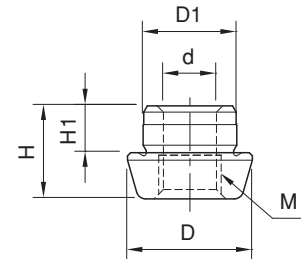

Montagedetails / Mounting Details

Referenz-Nr. Order No.	d (H6)	H2	M1	M2
1489-12025	12	5.5	M8x1.25	M6x1.00
1489-15032	15	8.5	M10x1.50	M8x1.25
1489-20045	20	11	M14x1.50	M12x1.75

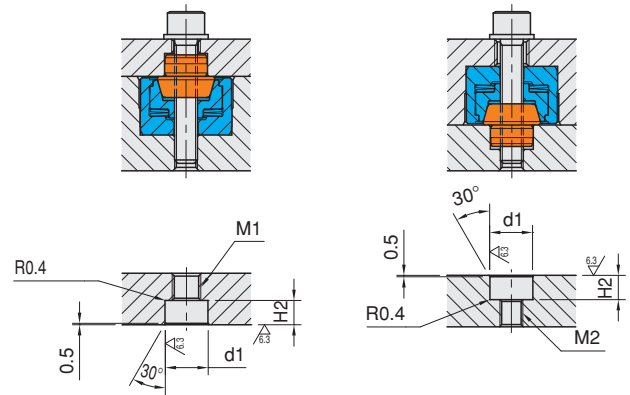
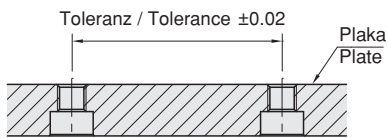

Referenz-Nr. Order No.	D	H	D1	M	
1489-12025P	15	10	9	M4x0.7	2
1489-15032P	19	13	11	M5x0.8	5
1489-20045P	29	18	16	M6x1.0	17

1489

Zentrierschutzkappe

Flex Locator Protecting Covers

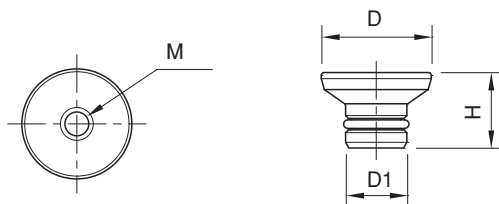

Montagedetails / Mounting Details

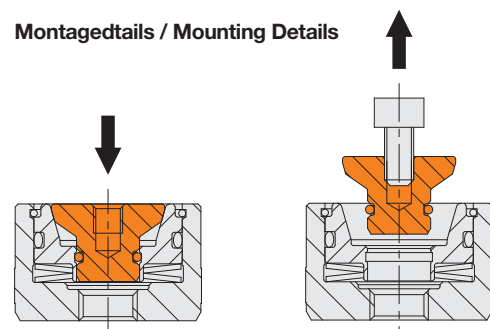

Referenz-Nr. Order No.	d1 g6	h3	d2	h1	D	h	d3 (h8)	h2	d	Lf	d4	dp	M	Luftdruck Air Pressure (MPa)	Spannkraft Clamping Force (N)	(g)
1489-18L4S	24	8	23.4	29.5	40	8	12	11	4.5	3.5	8	32	-	0.5	250	154
1489-26L4S	32	8.5	31.4	31.7	51	9.5	16	16	5.5	4	9.5	41	-	0.5	350	289
1489-18L4SG	24	8	23.4	29.5	40	8	12	11	4.5	3.5	8	32	M4x0.7	0.5	250	136
1489-26L4SG	32	8.5	31.4	31.7	51	9.5	16	16	5.5	4	9.5	41	M5x0.8	0.5	350	252

1489

- Nickel beschichtet
- Wiederholungsgenauigkeit ±10µm

1489

- Nickel Coating
- Repeat Accuracy ±10µm

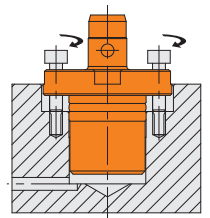
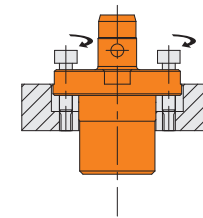
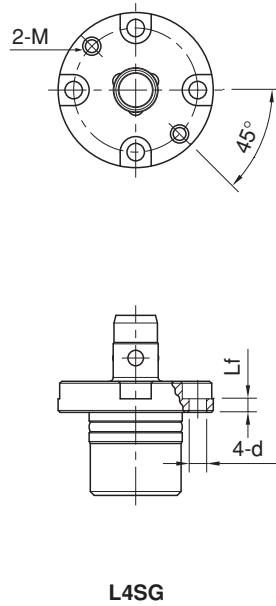
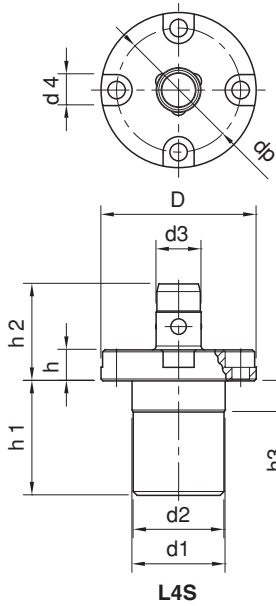

pneumatische Spannbuchse

Pneumatic Clamping Bush

Referenz-Nr. Order No.	D1 g6	h2	d2	h1	D	h	d e7	d1	Lf	d3	M	dp	(g)
1489-18BU	20	7.5	19.6	10.5	36	8	12.1	4.5	3.5	8	M4x0.7	28	57
1489-26BU	25	7	24.6	11	44	9.5	16.1	5.5	4	9.5	M5x0.8	34	97

1489

- Nickel beschichtet
- Wiederholungsgenauigkeit ±10µm

1489

- Nickel Coating
- Repeat Accuracy ±10µm

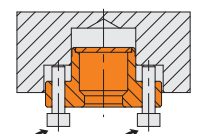
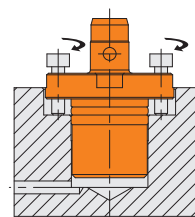
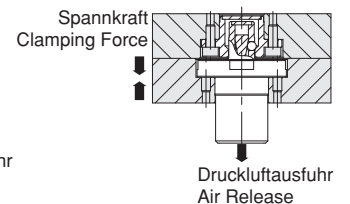
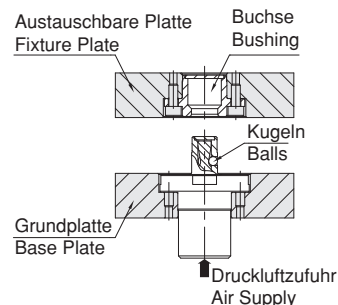
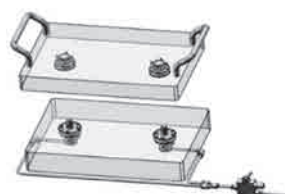
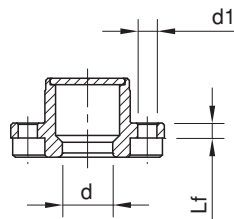
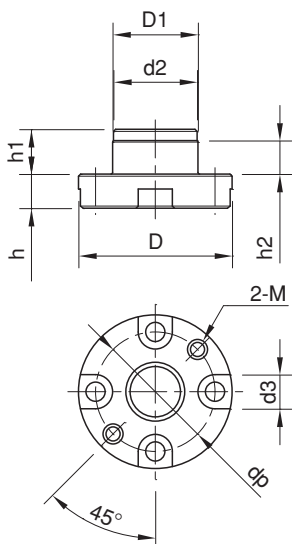

Stützelemente

Supports



Referenz-Nr. Order No.	D x F	d1	k	 (g)
1490-08032	M8x32	25	8	40
1490-10042	M10x42	30	8	60
1490-12050	M12x50	36	10	110
1490-12095	M12x95	36	10	150
1490-16062	M16x62	45	13	240
1490-16097	M16x97	45	13	285
1490-16117	M16x117	45	13	310
1490-20062	M20x62	50	13	320
1490-20097	M20x97	50	13	390
1490-20117	M20x117	50	13	430
1490-24081	M24x81	50	14	445
1490-24116	M24x116	50	14	555
1490-30180	M30x180	70	24	1650

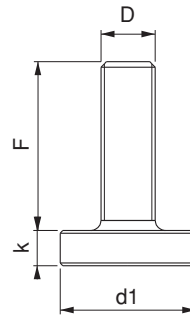

1490

- Schwarz beschichtet



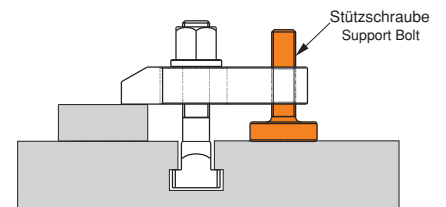

1490

- Black Coating



Höhen-Richtscharbstock

Trapeze Thread Lifter Support

Referenz-Nr. Order No.		d				kgf	 (g)
1510-023030	23-30	M16	34	32	1000	140	
1510-040060	40-60	M16	34	32	1800	250	
1510-042052	42-52	Tr 30x4	50	50	6000	570	
1510-050070	50-70	Tr 30x4	50	50	6000	680	
1510-070100	70-100	Tr 30x4	50	50	6000	960	
1510-100140	100-140	Tr 30x4	50	50	6000	1395	
1510-140220	140-220	Tr 30x4	54	54	6000	2285	
1510-210330	210-330	Tr 30x6	58	58	8000	3950	
1510-260430	260-430	Tr 30x6	68	68	8000	7250	

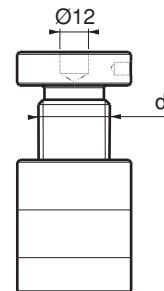

1510

- kompatibel mit Spannbacken DIN 6314-6315-6316
- Loch 12 mm auf beweglichem Werkstück verwendbar mit
- Nr. 1555-1560-1565-1570-1575 aufeinander zu unterschiedlichen Zwecken
- Schwarz beschichtet
- Stützschraube: gehartet

1510

- Nr.1510 Lifters are used in DIN 6314-6315-6316 clamps as the lifter support
- Hole with Ø12mm taking place on the moving part are used with the lifters with the Reference Nr.1 555-1560-1565-1570-1575 on top of each other and also used with different purpose.
- Black Coating
- Support Bolt : Hardened



Referenz-Nr. Order No.	H min.	H max.	D1	Ø12x50 H1 min.- H1 max.	Ø12x80 H1 min.- H1 max.	↓ Kgf	⚖ (g)
1515-065085	65	85	50	93-113	123-143	3000	810
1515-085125	85	125	50	113-153	143-183	3000	1050

Ürün Nr. 1515 Manyetik Vidalı Yükseltici

- Vorteil bei Horizontal-Spannen durch Magnet insbesondere bei Injektionsmaschinen
- Gehärtet
- Schwarz beschichtet

Product Nr. 1515 Magnetic Screw Booster

- Because of magnetic it holds its own weight. Therefore it provides using advantage in horizontal clamping especially on injection machines.
- Hardened
- Black coating

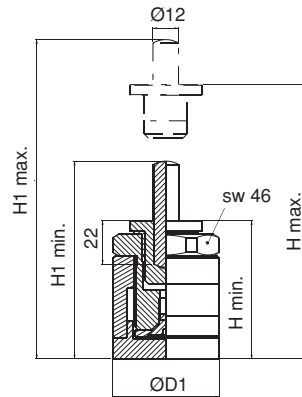

Schraubbock mit flacher Auflage und Magnetfuß - Gewinde

Referenz-Nr. Order No.	H min-max. A	H min-max. B	TR	d1	d2	d3	↓ kgf	⚖ (g)
1517-04262	42-52	52-62	30x4	50	50	53.5	6000	700
1517-05080	50-70	60-80	30x4	50	50	53.5	6000	770
1517-70110	70-100	80-110	30x4	50	50	53.5	6000	1050

- 1517**
- Schwarz beschichtet

- 1517**
- Black coating

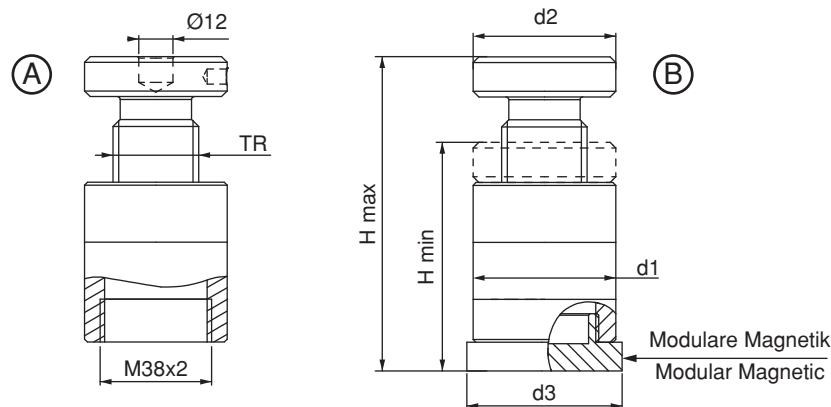

Referenz-Nr. Order No.	H min.	H max.	b1	b2	L	sw	↑ kgf	⚖ (g)
1520-050063	50	63	-	40	63	8	4000	1890
1520-100125	100	125	115	60	125	14	10000	9910
1520-170190	170	190	145	80	175	22	25000	28480

- 1520**
- konstruiert für Stützen und Heben schwerer Werkstücke
 - Gehärtet
 - Schwarz beschichtet

- 1520**
- Designed for supporting and lifting of heavy work pieces
 - Hardened
 - Black coating

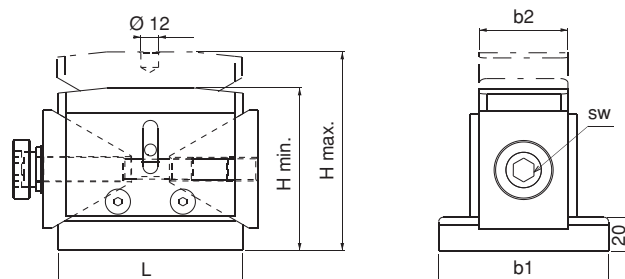

Richtkeil
Support Block



Referenz-Nr. Order No.		d	g	k	kgf	(kg)
1530-200	200-300	Tr40x7	69	28	8000	10.0
1530-280	280-460	Tr40x7	69	28	6000	11.8
1530-430	430-750	Tr40x7	69	28	5000	14.2
1530-710	710-1250	Tr40x7	69	28	4000	20.9

1530

- Verwendung bei hohen Teilen
- Grundkörper: Statisch lackiert
- Es bietet verschiedene Nutzungsvorteile, wenn das Loch Ø12mm verwendet wird, während 1555-1560-1560-1565-1565-1570-1575 referenznummerierte Produkte verwendet werden.

1530

- This is a trapeze thread lifting support having the purpose of using with High Pieces.
- Body and statical painting. It provides different usage advantages when Ø12mm hole is used with 1555-1560-1565-1570-1575 reference numbered products taking place.

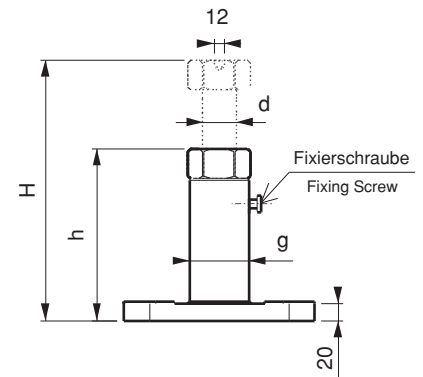
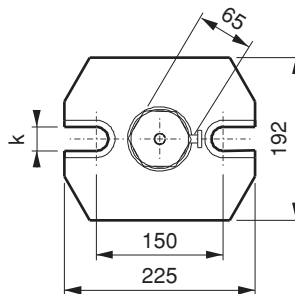

Referenz-Nr. Order No.		d	g	k	kgf	(kg)
1550-100	100-140	Tr30x6	49	18	6000	2.05
1550-140	140-200	Tr30x6	49	18	6000	2.45
1550-200	200-320	Tr30x6	49	22	4000	3.90
1550-320	320-550	Tr30x6	49	22	2500	5.15

1550

- Verwendung bei hohen Teilen
- Grundkörper: Statisch lackiert
- Es bietet verschiedene Nutzungsvorteile, wenn das Loch Ø12mm verwendet wird, während 1555-1560-1560-1565-1565-1570-1575 referenznummerierte Produkte verwendet werden.

1550

- This is a trapeze thread lifting support having the purpose of using with High Pieces.
- Body and statical painting. It provides different usage advantages when Ø12mm hole is used with 1555-1560-1565-1570-1575 reference numbered products taking place.

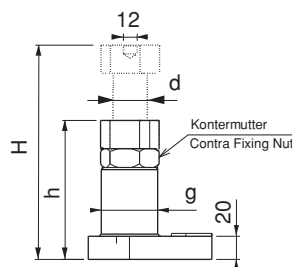
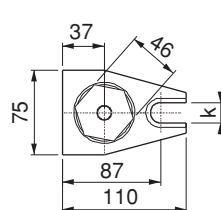
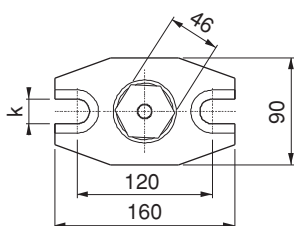

Referenz-Nr. Order No.	h	Ø d	
1555	10	37	75

Zubehör für Richt- und Stützelemente kompatibel mit Nr. 1510 + 1517 + 1530 + 1550

These products are used with the product Nos 1510-1517-1530-1550 taking place.

1555

- Vorteil bei winkligen Oberflächen
- Schwarz beschichtet

1555

- This part provides usage convenience on angled surfaces
- Black Coating

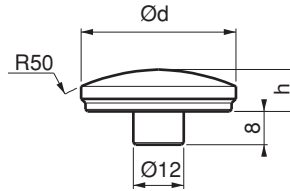
Kugelaufsatz
Rad-top Support



Referenz-Nr. Order No.	h	Ø d		
1560	25	45	3000	220

1560

- Vorteil bei ungleichförmigen Oberflächen
- Schwarz beschichtet

1560

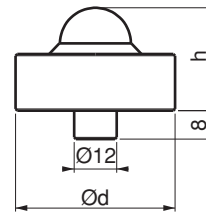
- This part provides usage convenience on irregular surfaces
- Black Coating

Aufsatz mit drehbarer Kugel
Ball Support



Referenz-Nr. Order No.	h	Ø d	Ø d1		
			min	max	
1565	15	45	10	50	130

1565

- Prisma für zylindrische Werkstücke
- Schwarz beschichtet

1565

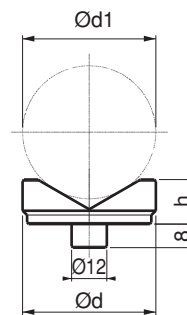
- V clamping block support for cylindrical pieces
- Black Coating

Prismaufsatz
V-Clamping Block



Referenz-Nr. Order No.	h	Ø d	Ø d1	L	
1570	12	50	15	20	220

1570

- Stütze bei geformten Werkstücken
- Schwarz beschichtet

1570

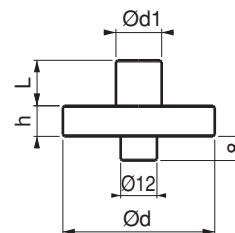
- This part provides support for formed pieces by entering in between
- Black Coating

Fixieraufsatz
Pin Support



Referenz-Nr. Order No.	h	Ø d	Ø d1	Ø d2	
1575	8	45	35.8	30	105

1575

- Verwendung bei Schraubstock
- Schwarz beschichtet

1575

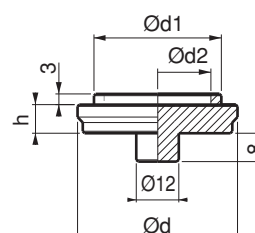
- This part is used as Intermediary Centering Mean when used with Trapeze Thread Lifters
- Black Coating

Zentrierplatte
Intermediary Centering Mean

Referenz-Nr. Order No.	h	a	c	k	b	L	b1	b2	
1580-050	13	8	13	37	52	50	52	78	460
1580-060	16	10	17	47	64	60	64	96	860
1580-070	19	13	18	57	76	70	76	114	1420

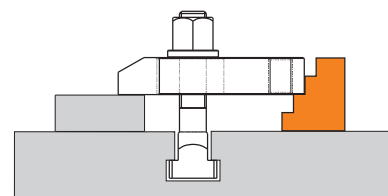
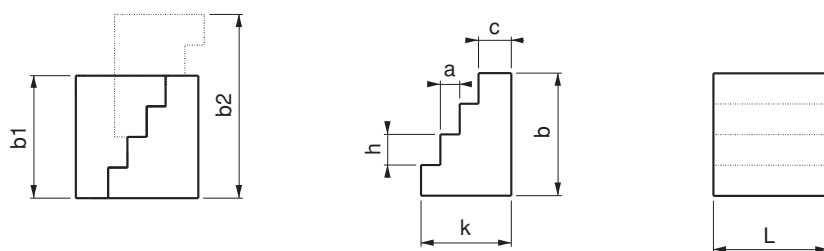

1580
• Schwarz beschichtet

1580
• Black Coating



gezahnte Spannunterlagen

Serrated Thread Combined Support

Referenz-Nr. Order No.	h-H	e	 kgf	
1585-050	110-150	48x48	4000	1120
1585-060	155-220	60x58	5000	2710
1585-080	220-340	80x78	6000	6560

1585
• Stufenhöhe 3 mm
• Schwarz beschichtet

1585
• Lifting gap (screw pitch) is 3 millimeters
• Black Coating

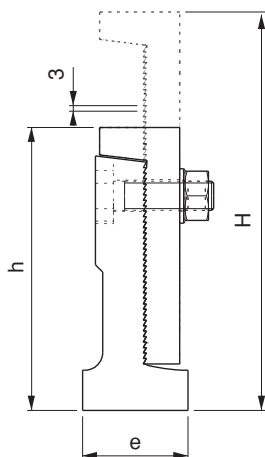

Referenz-Nr. Order No.	h	s	M1	d1	d	M	L	w	h1	L1	M2	zulässiges Drehmoment Allowable Screw Torque(Nm) a	Stütze Kapazität Support Capacity (kgf)	Kolbenfederkraft Piston Spring Force (N)	(g)
1588-060	33	6	M6x12	14	28	M6	10	4	22	14.1	M6x16	7.5	400	10~22	150
1588-080	42	10	M8x16	19	35	M8	15	5	28.5	18.8	M8x20	14	600	10~27	300
1588-100	50	10	M10x20	22	42	M10	14	6	34	23.8	M10x25	18	750	14~28	540
1588-120	60	10	M12x24	26	50	M12	17	8	42	28.5	M12x30	22	900	15~30	865
1588-160	70	10	M16x32	33	60	M16	22	10	47	26.5	M12x30	25	900	15~35	1.390

1588
• Schwarz beschichtet

1588
• Black coating

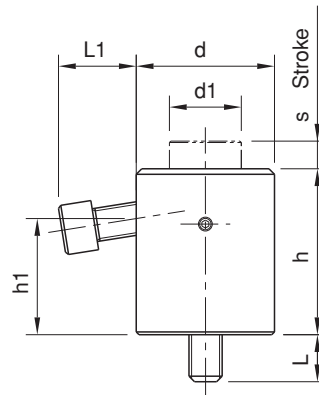
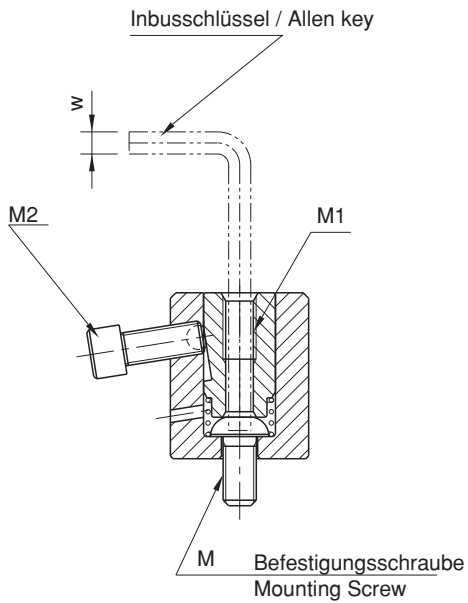
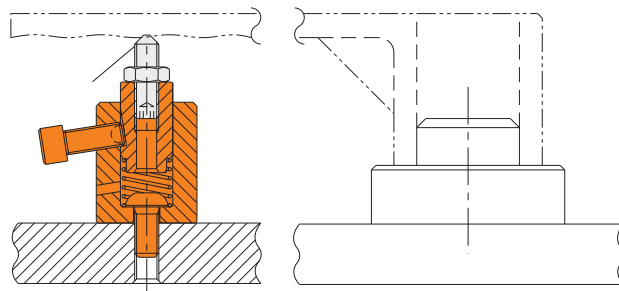
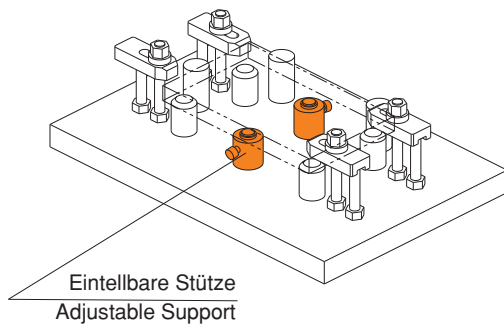
Anwendungsbeispiel / Application Examples

Schrauben

Bolts



	Festigkeitsklasse Quality Strength Classes		
	10	10.9	12.9
DIN 787 	-	-	X
DIN 6379 	-	X	-
DIN 6330B DIN 6331 Nr. 1830 	X	-	-
Zugfestigkeit [N/mm ²] Nominal tensile strength [N/mm ²]	1000	1000	1200
Streckgrenze [N/mm ²] Minimum yield point [N/mm ²]	-	900	1080

ERLÄUTERUNG ZUR TABELLE:

ZULÄSSIGE SCHRAUBENBELASTUNG ist die Zugbelastung, mit der die Schraube bei axial und zentrisch angreifender Betriebskraft durch die Summe aller wirkenden Kräfte maximal beansprucht werden darf. Die Streckgrenze wird zur Sicherheit üblicherweise nur zu 80% ausgenutzt.

ZULÄSSIGE VORSPANNKRAFT ist die Kraft, mit der die Schraube beim Anziehen der Mutter maximal vorgespannt werden darf. Die Tabellenwerte gelten bei einer Reibung von $\mu = 0,14$ an den Auflagflächen und im Gewinde, dies entspricht der Reibung bei mittlerer Oberfläche in gefettetem Zustand.

ERFORDERLICHE HEBELLÄNGEN: Diese Hebellängen werden mit dem Mittelwert der Handkräfte errechnet, die bei einer Versuchsreihe von verschiedenen Arbeitern erreicht wurden.

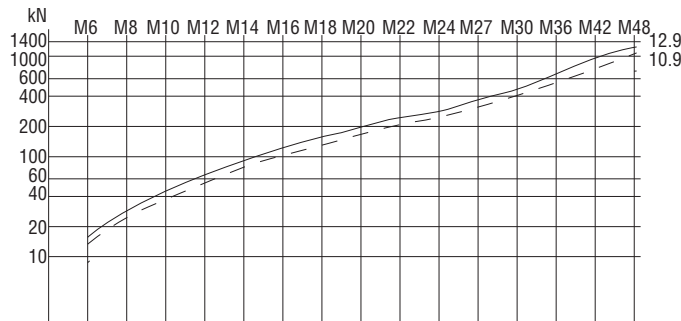

Festigkeit der passenden schrauben
Pre-stress Force With Standard Spanner

Explanation Of Table Characteristics:

- **Permissible Bolt Load:** is the maximum tension load, the screw can be stressed with taking into account all active forces. The yield point is only utilized to 80% for safety.
- **Permissible Pre-stress Force:** is the load, the screw can be pre-stressed at most, when tightening the matching nut. Figures of table are valid for a friction of $\mu = 0,14$ in thrust faces and thread, corresponding to the friction of greased medium faces.
- **Allowed pretension with oil calculation:** At an application with screws and nuts, the load must be calculated with a $\mu = 0,1$ frictional factor of the workpiece.

SCHRAUBEN- UND MUTTERN-FESTIGKEITEN UND ANZIEHDREHMOMENTE: / Strength Figures And Torques For Bolts And Nuts:

Gewinde / Threads	Festigkeitsklasse Quality	M6	M8	M10	M12	M14	M16	M18	M20	M22	M24	M27	M30	M36	M42	M48	
Steigung / Pitch of thread	mm	1	1.25	1.50	1.75	2	2	2.50	2.50	2.50	3	3	3.50	4	4.50	5	
Muttern / Nuts																	
Härte / Hardness DIN 6330 / 6331 / 6334	HRC	10															
Prüfkraft (AS x Sp) Test force DIN EN 20898-2	kN	10	20.9	38.1	60	88	121	165	203	260	321	374	486	595	866	-	-
Muttern für T-Nutten / Nuts for T-Slots DIN 508 / Nr. 1710																	
Größe / Size		M6x8	M8x10	M10x12	M12x14	-	M16x18	-	M20x22	-	M24x28	-	M30x36	M36x42	M42x48	M48x54	
Härte / Hardness	HRC	22 - 30															
Prüfkraft / Test Force	kN	16	29	46	67	-	128	-	196	-	282	-	448	653	653	653	
Schrauben / Bolts																	
Härte / Hardness	HRC	10.9	32 - 39										12.9	39 - 44			

Anziehwerte / Tightening Data

Mindestbruchkraft Minimum Breaking Force (AS x Rm)	kN	10.9	21	38	60	88	(120)	(163)	(200)	(255)	(315)	(367)	(477)	(583)	(850)	(1165)	(1531)
Zulässige Schraubenbelastung max. 80% der Streckgrenze Permissible bolt load max. 80% of yield point	kN	10.9	14	27	43	63	86	118	144	184	228	265	345	421	614	843	1107
Prüfkraft (AS x Sp) nach DIN EN ISO 898, Teil 1 Test force (AS x Sp) to DIN EN ISO 898, part 1	kN	10.9	17	30	48	70	(96)	(130)	(159)	(203)	(252)	(293)	(381)	(466)	(678)	(930)	(1222)
Zulässige Vorspannkraft bei 90% Streckgrenzansatz kN zung und Reibung $\mu = 0,14$ Permissible pre-stress force max. 90% of yield Point and friction $\mu = 0,14$	kN	10.9	13	25	38	55	77	107	130	167	208	240	315	384	561	773	1018
Erforderliches Anziehdrehmoment für zulässige Vorspannkraft mit der üblichen Handkraft Required torque for permissible pre-stress Force and friction $\mu = 0,14$	Nm	10.9	14	36	67	120	191	302	405	580	772	994	1455	1930	3378	5415	8162
Erford. Hebellänge zum Erreichen der zulässigen Vorspannkraft mit der üblichen Handkraft Required length for lever to achieve permissible pre-stress force	mm	10.9	42	90	175	300	450	700	920	1200	1560	-	-	-	-	-	-
Mögl. Drehmoment mit normalen Ringschlüssel und Drehkraft Daraus resultiert Vorspannkraft Possible torque to obtain with standard spanner, resulting Prestress force	Nm kN	-	60	80	90	100	110	125	140	150	170	185	225	240	300	330	410
Mit dieser Vorspannkraft With this pre-stress force there is danger of	10.9 12.9	Bruchgefahr breakage		Filegefahr deformation		Gefahr des Lösens der gespannten Teile bei einsetzender Betriebskraft loosening of clamping unit at start of motive force											

As = Nennspanquerschnitt in mm²
As = Nominal cross section in mm²

Sp = Prüfspannung in N / mm²
Sp = min. Clamping force in N/mm²

Rm = Mindestzugfestigkeit in N/mm²
Rm = min. load factor in N/mm²

μ = Reibungszahl
 μ = friction

Referenz-Nr. Order No.	dx	x L	b	a	e	k	Spannwerte Tightening Data		
							Nm	kN	
1590-0606025	M6x6	x25	15	5.7	10	4	17	17	8
1590-0606040		x40	28						11
1590-0606063		x63	40						15
1590-0808032	M8x8	x32	22	7.7	12	6	43	32	13
1590-0808050		x50	35						16
1590-0808080		x80	50						20
1590-1010040	M10x10	x40	23	9.7	15	6	79	51	35
1590-1010063		x63	45						45
1590-1010080		x80	50						60
1590-1010100	x100	60	70						
1590-1012050	M10x12	x50	35	11.7	18	7	79	51	50
1590-1012063		x63	40						60
1590-1012080		x80	55						65
1590-1012100		x100	60						75
1590-1012125		x125	75						90
1590-1012160		x160	90						105
1590-1012200	x200	120	120						
1590-1212050	M12x12	x50	35	11.7	18	7	141	74	65
1590-1212063		x63	40						70
1590-1212080		x80	55						80
1590-1212100		x100	65						100
1590-1212125		x125	75						110
1590-1212160		x160	100						140
1590-1212200	x200	120	160						
1590-1214050	M12x14	x50	35	13.7	22	8	141	74	80
1590-1214063		x63	45						90
1590-1214080		x80	55						100
1590-1214100		x100	65						110
1590-1214125		x125	75						135
1590-1214160		x160	100						160
1590-1214200	x200	120	180						
1590-1416063	M14x16	x63	45	15.7	25	9	223	101	115
1590-1416080		x80	55						140
1590-1416100		x100	65						160
1590-1416125		x125	75						180
1590-1416160		x160	100						220
1590-1416200		x200	120						255
1590-1416250	x250	150	300						
1590-1616063	M16x16	x63	45	15.7	25	9	354	138	140
1590-1616080		x80	55						160
1590-1616100		x100	65						190
1590-1616125		x125	85						225
1590-1616160		x160	100						270
1590-1616200		x200	120						315
1590-1616250	x250	150	380						
1590-1618063	M16x18	x63	45	17.7	28	10	354	138	170
1590-1618080		x80	55						185
1590-1618100		x100	65						220
1590-1618125		x125	85						245
1590-1618160		x160	100						295
1590-1618200		x200	120						340
1590-1618250	x250	150	405						
1590-1820080	M18x20	x80	55	19.7	32	12	474	169	260
1590-1820100		x100	65						290
1590-1820125		x125	85						340
1590-1820160		x160	110						390
1590-1820200		x200	125						455
1590-1820250		x250	150						535
1590-1820315	x315	190	650						
1590-2020080	M20x20	x80	55	19.7	32	12	679	215	300
1590-2020100		x100	65						330
1590-2020125		x125	85						380
1590-2020160		x160	110						450
1590-2020200		x200	125						535
1590-2020250		x250	160						635
1590-2020315	x315	190	760						
1590-2022080	M20x22	x80	55	21.7	35	14	679	215	345
1590-2022100		x100	65						380
1590-2022125		x125	85						435
1590-2022160		x160	110						500
1590-2022200		x200	125						590
1590-2022250		x250	150						695
1590-2022315	x315	190	820						

Referenz-Nr. Order No.	dx	x L	b	a	e	k	Spannwerte Tightening Data		
							Nm	kN	
1590-2224080	M22x24	x80	55	23.7	40	16	903	266	465
1590-2224100		x100	65						515
1590-2224125		x125	85						580
1590-2224200		x160	110						660
1590-2224250		x200	125						775
1590-2224315	x250	150	805						
1590-2224315	x315	190	1050						
1590-2424100	M24x24	x100	70	23.7	40	16	1163	310	550
1590-2424125		x125	85						630
1590-2424160		x160	110						725
1590-2424200		x200	125						850
1590-2424250		x250	150						990
1590-2424315		x315	190						1180
1590-2424400	x400	240	1410						
1590-2428100	M24x28	x100	70	27.7	44	18	1163	310	660
1590-2428125		x125	85						730
1590-2428160		x160	110						820
1590-2428200		x200	125						950
1590-2428250		x250	150						1090
1590-2428315		x315	190						1300
1590-2428400	x400	240	1530						
1590-2428500	x500	290	1800						
1590-3036125	M30x36	x125	80	35.6	54	22	2258	493	1280
1590-3036160		x160	110						1440
1590-3036200		x200	135						1620
1590-3036250		x250	150						1880
1590-3036315		x315	200						2150
1590-3036500	x500	300	3010						
1590-3642160	M36x42	x160	100	41.6	65	26	3953	719	2260
1590-3642250		x250	175						2890
1590-3642400		x400	250						4010
1590-3642600	x600	340	5900						
1590-4248160	M42x48	x160	100	47.6	75	30	6337	986	3550
1590-4248250		x250	175						4530
1590-4248400		x400	250						6160

DIN 787
1590

- Qualität 12.9
- Schwarz beschichtet

1590

- Quality 12.9
- Black coating





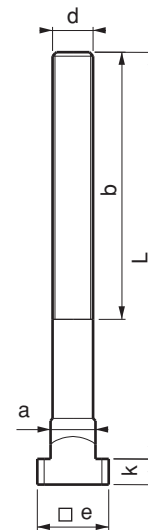

Loctite 8150

Hinweis: Bei Anwendung über 150 °C ist auf das Gewinde Loctite 8150 aufzutragen.

Note: Environments on the 150 °C when clamping action on the thread Loctite 8150 is used.



Referenz-Nr. Order No.	dx 	x L	b	a	e	k	Spannwerte Tightening Data		
							Nm	kN	
1610-0606025	M6x6	x25	15	5.7	10	4	17	17	19
1610-0606040		x40	28						25
1610-0606063		x63	40						36
1610-0808032	M8x8	x32	22	7.7	12	6	43	32	39
1610-0808050		x50	35						45
1610-0808080		x80	50						56
1610-1010040	M10x10	x40	23	9.7	15	6	79	51	65
1610-1010063		x63	45						80
1610-1010080		x80	50						90
1610-1010100	x100	60	110						
1610-1012050	M10x12	x50	35	11.7	18	7	79	51	85
1610-1012063		x63	40						95
1610-1012080		x80	55						100
1610-1012100	x100	60	110						
1610-1012125	x125	75	125						
1610-1012160	x160	90	140						
1610-1012200	x200	120	160						
1610-1212050	M12x12	x50	35	11.7	18	7	141	74	120
1610-1212063		x63	40						128
1610-1212080		x80	55						140
1610-1212100	x100	65	160						
1610-1212125	x125	75	170						
1610-1212160	x160	100	195						
1610-1212200	x200	120	220						
1610-1214050	M12x14	x50	35	13.7	22	8	141	74	140
1610-1214063		x63	45						150
1610-1214080		x80	55						155
1610-1214100	x100	65	175						
1610-1214125	x125	75	195						
1610-1214160	x160	100	220						
1610-1214200	x200	120	240						
1610-1416063	M14x16	x63	45	15.7	25	9	223	101	200
1610-1416080		x80	55						230
1610-1416100		x100	65						245
1610-1416125	x125	75	270						
1610-1416160	x160	100	310						
1610-1416200	x200	120	340						
1610-1416250	x250	150	390						
1610-1616063	M16x16	x63	45	15.7	25	9	354	138	260
1610-1616080		x80	55						285
1610-1616100		x100	65						310
1610-1616125	x125	85	345						
1610-1616160	x160	100	385						
1610-1616200	x200	120	435						
1610-1616250	x250	150	505						
1610-1618063	M16x18	x63	45	17.7	28	10	354	138	290
1610-1618080		x80	55						305
1610-1618100		x100	65						340
1610-1618125	x125	85	370						
1610-1618160	x160	100	415						
1610-1618200	x200	120	460						
1610-1618250	x250	150	525						
1610-1820080	M18x20	x80	55	19.7	32	12	474	169	405
1610-1820100		x100	65						435
1610-1820125		x125	85						480
1610-1820160	x160	110	535						
1610-1820200	x200	125	610						
1610-1820250	x250	150	680						
1610-1820315	x315	190	790						
1610-2020080	M20x20	x80	55	19.7	32	12	679	215	480
1610-2020100		x100	65						515
1610-2020125		x125	85						570
1610-2020160	x160	110	635						
1610-2020200	x200	125	725						
1610-2020250	x250	160	820						
1610-2020315	x315	190	950						
1610-2022080	M20x22	x80	55	21.7	35	14	679	215	530
1610-2022100		x100	65						565
1610-2022125		x125	85						620
1610-2022160	x160	110	690						
1610-2022200	x200	125	775						
1610-2022250	x250	150	880						
1610-2022315	x315	190	1050						

Referenz-Nr. Order No.	dx 	x L	b	a	e	k	Spannwerte Tightening Data		
							Nm	kN	
1610-2224080	M22x24	x80	55	23.7	40	16	903	266	700
1610-2224100		x100	65						740
1610-2224125		x125	85						805
1610-2224160	x160	110	890						
1610-2224200	x200	125	1000						
1610-2224250	x250	150	1115						
1610-2224315	x315	190	1280						
1610-2424100	M24x24	x100	70	23.7	40	16	1163	310	885
1610-2424125		x125	85						970
1610-2424160		x160	110						1060
1610-2424200	x200	125	1180						
1610-2424250	x250	150	1320						
1610-2424315	x315	190	1515						
1610-2424400	x400	240	1750						
1610-2428100	M24x28	x100	70	27.7	44	18	1163	310	1000
1610-2428125		x125	85						1065
1610-2428160		x160	110						1150
1610-2428200	x200	125	1280						
1610-2428250	x250	150	1425						
1610-2428315	x315	190	1640						
1610-2428400	x400	240	1870						
1610-2428500	x500	290	2170						
1610-3036125	M30x36	x125	80	35.6	54	22	2258	493	1900
1610-3036160		x160	110						2065
1610-3036200		x200	135						2250
1610-3036250	x250	150	2500						
1610-3036315	x315	200	2770						
1610-3036500	x500	300	3630						
1610-3642160	M36x42	x160	100	41.6	65	26	3953	719	3310
1610-3642250		x250	175						3930
1610-3642400		x400	250						5010
1610-3642600	x600	340	6900						
1610-4248160	M42x48	x160	100	47.6	75	30	6337	986	4600
1610-4248250		x250	175						5600
1610-4248400		x400	250						7200

DIN 787

1610

- Qualität 12.9
- Schwarz beschichtet

1610

- Quality 12.9
- Black coating

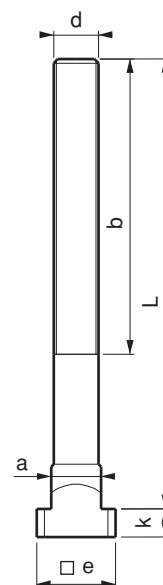



Hinweis: Bei Anwendung über 150 C° ist Auf das Gewinde Loctite 8150 aufzutragen.

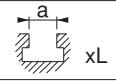

Loctite 8150

Note: Environments on the 150 °C when clamping action on the thread Loctite 8150 is used.

Referenz-Nr. Order No.	dx  xL	a	e	k	h-H	e1	e2	c	s	f	sw	Spannwerte Tightening Data		
												Nm	kN	
1630-2022200	M20x22x200	21.7	35	14	25-75	49	69	92	12	30	30	679	215	1635
1630-2022250	M20x22x250	21.7	35	14	70-120	49	69	92	12	30	30	679	215	1720
1630-2424200	M24x24x200	23.7	40	16	25-75	53	74	92	12	30	36	1163	310	2075
1630-2424250	M24x24x250	23.7	40	16	70-120	53	74	92	12	30	36	1163	310	2250
1630-2428200	M24x28x200	27.7	44	18	25-75	53	74	92	12	30	36	1163	310	2180
1630-2428250	M24x28x250	27.7	44	18	70-120	53	74	92	12	30	36	1163	310	2340
1630-3036200	M30x36x200	35.6	54	22	25-75	68	88	94	14	30	46	2258	493	3660
1630-3036250	M30x36x250	35.6	54	22	70-120	68	88	94	14	30	46	2258	493	3910

1630

- Verwendung bei schweren Pressen, großen Werkzeugen
- Lockerungen aufgrund Vibrationen werden durch Konterspannen verhindert
- Qualität 12.9
- Schwarz beschichtet

1630

- Because of it's contra tightening structure, it prevents loosening which may be generated by the vibration during working with heavy presses and big moulds.
- Quality 12.9
- Black coating



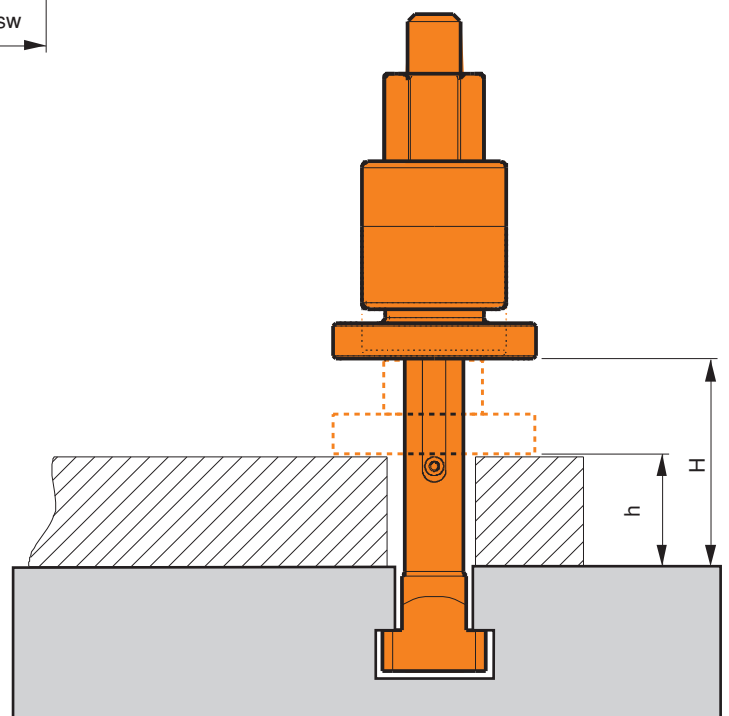
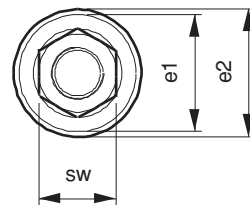
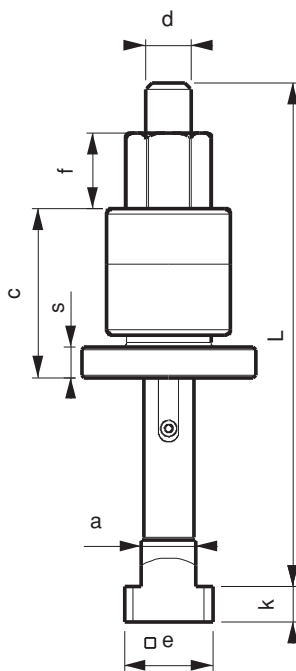

Hinweis: Bei Anwendung über 150 °C ist Auf das Gewinde Loctite 8150 aufzutragen.

Note: Environments on the 150 °C when clamping action on the thread Loctite 8150 is used.



Loctite 8150

Referenz-Nr. Order No.	dx  x L	b	a	e	k	Spannwerte Tightening Data		
						Nm	kN	
1650-1214050	x50	35						70
1650-1214080	M12x14 x80	55	13.7	22	8	141	74	100
1650-1214125	x125	75						120
1650-1618063	x63	45						160
1650-1618100	M16x18 x100	65	17.7	28	10	354	138	220
1650-1618160	x160	100						280
1650-2022080	x80	55						330
1650-2022125	M20x22 x125	85	21.7	35	14	679	215	430
1650-2022200	x200	120						570
1650-2428100	x100	70						650
1650-2428125	M24x28 x125	85	27.7	44	18	1163	310	770
1650-2428250	x250	150						1150

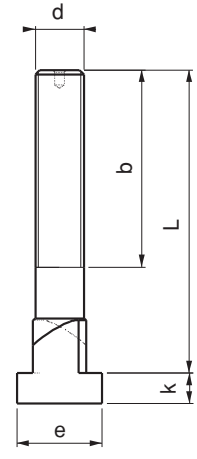

1650

- Eigenschaft: Bei Platten mit T-Nut von oben stecken und spannen
- Qualität 12.9
- Schwarz beschichtet

1650

- In "T" slot plates it has the feature of making the coupling by entering "T" from the top.
- Quality 12.9
- Black Coating

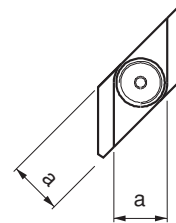

Hinweis: Verwenden Sie die Marke Loctite Produktcode 8150 auf dem Bolzengewinde während Werkstück Umgebung oberhalb von 150 ° C Klemm



Note: Use Loctite brand product code 8150 on the bolt thread while clamping workpiece environment above 150 ° C

Schraube mit Schlüsselweite für T-Nut

Wrench Mouth Stud

Referenz-Nr. Order No.	d	L	b	b1	m	sw	Spannwerte Tightening Data		
							Nm	kN	
1670-12130	M12	130	65	24	14	14	120	63	160
1670-12160		160	90						185
1670-14130	M14	130	65	28	15	15	191	86	216
1670-14160		160	90						246
1670-16140	M16	140	70	32	16	17	302	118	310
1670-16160		160	95						340
1670-18150	M18	150	70	35	19	19	405	144	395
1670-18180		180	95						450
1670-20150	M20	150	70	40	22	22	580	184	520
1670-20180		180	95						575
1670-22150	M22	150	70	40	22	24	772	228	610
1670-22180		180	95						705
1670-24170	M24	170	75	47	22	27	994	265	875
1670-24205		205	105						990
1670-24250		250	140						1125
1670-30250	M30	250	135	55	32	36	1930	421	1950
1670-30315		315	195						2260

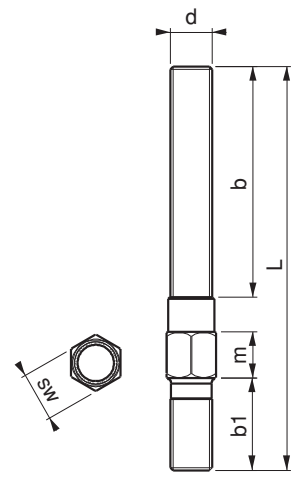

1670

- Verwendung bei Injektionsmaschinen und Platten mit Gewinde
- Qualität 10.9
- Schwarz beschichtet

1670

- Area of Use: This stud is used in injection machines and in plates with M12-14-16-18-20-22-24-30 threads
- Quality 10.9
- Black Coating

Hinweis: Verwenden Sie die Marke Loctite Produktcode 8150 auf dem Bolzengewinde während Werkstück Umgebung oberhalb von 150 ° C Klemm

Note: Use Loctite brand product code 8150 on the bolt thread while clamping workpiece environment above 150 ° C



Referenz-Nr. Order No.	d x L	b1	b	Spannwerte Tightening Data		 (g)
				Nm	kN	
1690-08040 1690-08063 1690-08080 1690-08100 1690-08125 1690-08160	M8 x40 x63 x80 x100 x125 x160	11	20 40 50 63 75 100	36	27	10 15 20 30 35 45
1690-10050 1690-10063 1690-10080 1690-10100 1690-10125 1690-10160 1690-10200	M10 x50 x63 x80 x100 x125 x160 x200	13	25 32 50 63 75 100 125	67	43	20 25 35 45 55 70 95
1690-12050 1690-12063 1690-12080 1690-12100 1690-12125 1690-12160 1690-12200	M12 x50 x63 x80 x100 x125 x160 x200	15	25 32 50 63 75 100 125	120	63	35 40 55 70 90 115 140
1690-14063 1690-14080 1690-14100 1690-14125 1690-14160 1690-14200 1690-14250	M14 x63 x80 x100 x125 x160 x200 x250	17	32 50 63 75 100 125 160	191	86	60 75 95 120 150 195 240
1690-16063 1690-16080 1690-16100 1690-16125 1690-16160 1690-16200 1690-16250 1690-16315 1690-16500	M16 x63 x80 x100 x125 x160 x200 x250 x315 x500	19	32 50 63 75 100 125 160 180 315	302	118	85 105 130 160 205 260 325 405 650
1690-18080 1690-18100 1690-18125 1690-18160 1690-18200 1690-18250 1690-18315	M18 x80 x100 x125 x160 x200 x250 x315	23	50 60 75 100 125 150 180	405	144	130 160 200 260 320 400 510
1690-20080 1690-20100 1690-20125 1690-20160 1690-20200 1690-20250 1690-20315 1690-20400 1690-20500	M20 x80 x100 x125 x160 x200 x250 x315 x400 x500	27	32 60 70 100 125 160 200 250 315	580	184	155 200 250 330 400 510 640 815 1020
1690-22100 1690-22125 1690-22160 1690-22200 1690-22250 1690-22315 1690-22400	M22 x100 x125 x160 x200 x250 x315 x400	31	45 70 100 125 160 180 250	772	228	250 305 400 500 620 780 1010
1690-24100 1690-24125 1690-24160 1690-24200 1690-24250 1690-24315 1690-24400 1690-24500 1690-24630	M24 x100 x125 x160 x200 x250 x315 x400 x500 x630	35	45 70 100 125 160 200 250 315 315	994	265	290 365 470 580 730 920 1170 1470 1860
1690-30125 1690-30200 1690-30250 1690-30315 1690-30500 1690-30700 1690-301000	M30 x125 x200 x250 x315 x500 x700 x1000	43	56 125 160 200 315 400 400	1930	421	570 910 1150 1435 2315 3215 4700

Referenz-Nr. Order No.	d x L	b1	b	Spannwerte Tightening Data		 (g)
				Nm	kN	
1690-36160 1690-36200 1690-36250 1690-36315 1690-36400 1690-36500 1690-36700	M36 x160 x200 x250 x315 x400 x500 x700	51	80 125 160 200 250 315 400	3378	614	1100 1340 1710 2150 2700 3450 4750
1690-42315 1690-42400 1690-42500	M42 x315 x400 x500	59	200 250 315	5415	843	2950 3750 4690

DIN 6379
1690

- Qualität 10.9
- Schwarz beschichtet

1690

- Quality 10.9
- Black coating

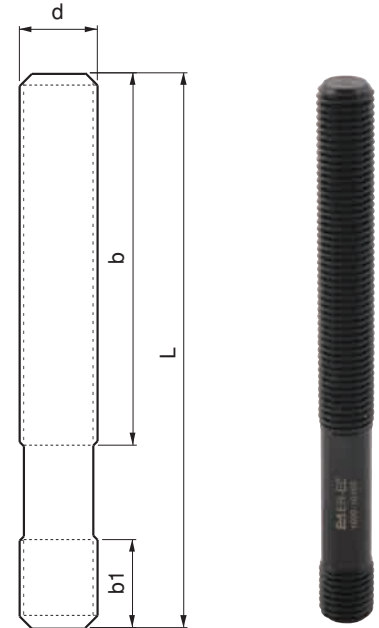

Hinweis: Bei Anwendung über 150 °C ist Auf das Gewinde Loctite 8150 aufzutragen.

Note: Environments on the 150 °C when clamping action on the thread Loctite 8150 is used.



Sechskantmutter, Scheibe, Zubehör

Nut, Washer, Accessories



Referenz-Nr. Order No.		a	e	l	h	k	
1710-0608	M6x8	7.7	13	26	10	6	14
1710-0810	M8x10	9.7	15	30	12	6	25
1710-1012	M10x12	11.7	18	36	14	7	49
1710-1214	M12x14	13.7	22	44	16	8	82
1710-1416	M14x16	15.7	25	50	18	9	120
1710-1618	M16x18	17.7	28	56	20	10	165
1710-1820	M18x20	19.7	32	64	24	12	260
1710-2022	M20x22	21.7	35	70	28	14	365
1710-2224	M22x24	23.7	40	80	32	16	535
1710-2428	M24x28	27.7	44	88	36	18	745
1710-3036	M30x36	35.6	54	108	44	22	1390

1710

- schützt T-Kanal bei empfindlichen Maschinenplatten
- Gehärtet
- Schwarz beschichtet
- Qualität 10.

1710

- This clamp protects T-Slot in sensitive machine plates
- Hardened
- Black coating
- Quality 10

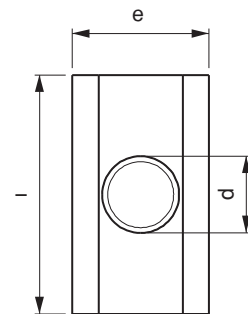
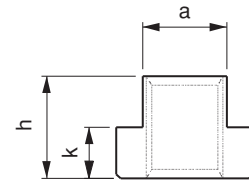

Referenz-Nr. Order No.		a	e	h	k	
1730-06	6	5.7	10	8	4	4
1730-08	8	7.7	13	10	6	10
1730-10	10	9.7	15	12	6	16
1730-12	12	11.7	18	14	7	27
1730-14	14	13.7	22	16	8	50
1730-16	16	15.7	25	18	9	70
1730-18	18	17.7	28	20	10	95
1730-20	20	19.7	32	24	12	150
1730-22	22	21.7	35	28	14	210
1730-24	24	23.7	40	32	16	310
1730-28	28	27.7	44	36	18	430
1730-36	36	35.6	54	44	22	800
1730-42	42	41.6	65	52	26	1400

1730

- Gewindebohren und lochen nach Bedarf

1730

- Arbitrary thread cutting can be applied

Muttern-Rohling für T-Nuten

T-Nut without Hole

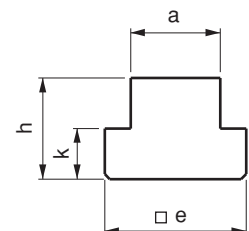

Referenz-Nr. Order No.	dx	a	e	h	k	 (g)
1750-0506	M5x6	5.7	10	8	4	4
1750-0608	M6x8	7.7	13	10	6	10
1750-0810	M8x10	9.7	15	12	6	12
1750-0812	M8x12*	11.7	18	14	7	22
1750-1012	M10x12					20
1750-0814	M8x14*					40
1750-1014	M10x14*	13.7	22	16	8	37
1750-1214	M12x14					30
1750-0816	M8x16*					60
1750-1016	M10x16*	15.7	25	18	9	55
1750-1216	M12x16*					55
1750-1416	M14x16					45
1750-0818	M8x18*					90
1750-1018	M10x18*	17.7	28	20	10	87
1750-1218	M12x18*					80
1750-1418	M14x18*					75
1750-1618	M16x18					65
1750-1620	M16x20*	19.7	32	24	12	115
1750-1820	M18x20					105
1750-1622	M16x22*	21.7	35	28	14	170
1750-1822	M18x22*					160
1750-2022	M20x22					150
1750-1624	M16x24*	23.7	40	32	16	260
1750-2024	M20x24*					240
1750-2224	M22x24					220
1750-1628	M16x28*	27.7	44	36	18	375
1750-2028	M20x28*					350
1750-2228	M22x28*					330
1750-2428	M24x28					330
1750-2436	M24x36*	35.6	54	44	22	665
1750-3036	M30x36					585
1750-3642	M36x42	41.6	65	52	26	1025
1750-4248	M42x48	47.6	75	60	30	1600

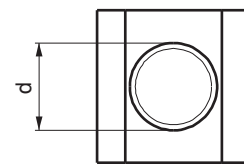
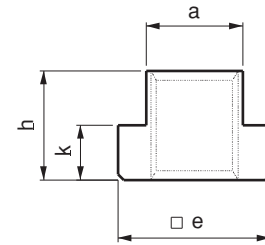
DIN 508
1750

- Für die Lebensdauer der T-Nutenstein muss das gesamte Gewindeteil genutzt werden.
- Gehärtet
- Schwarz beschichtet
- Qualität 10.

1750

- Screwing must be done on the entire thread part for the endurance of T-Nut
- Hardened
- Black coating
- Quality 10

Referenz-Nr. Order No.	dx	a	e	h	k	 (g)
1770-0810	M8x10	9.7	15	12	6	10
1770-1012	M10x12	11.7	18	14	7	15
1770-1014	M10x14*	13.7	22	16	8	30
1770-1214	M12x14					25
1770-1416	M14x16	15.7	25	18	9	40
1770-1018	M10x18*	17.7	28	20	10	70
1770-1618	M16x18					60
1770-1620	M16x20*	19.7	32	24	12	95
1770-1820	M18x20					90
1770-1622	M16x22*	21.7	35	28	14	135
1770-2022	M20x22					125
1770-1628	M16x28*	27.7	44	36	18	330
1770-2028	M20x28*					295
1770-2428	M24x28					265

Ürün Nr. 1770 Dereceli T-Pabuç

- Vorteil: Stecken von oben und spannen bei Platten mit T-Nuten
- Gehärtet
- Schwarz beschichtet
- Qualität 10.

Product Nr. 1770 Graded T-Nut

- It has the feature of making the coupling by entering T-Slot plates from the top
- Hardened
- Black coating
- Quality 10

Mutter für T-Nut "Rhombus"

Graded T-Nut

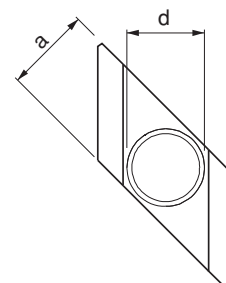
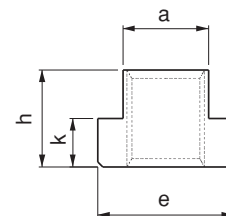

Referenz-Nr. Order No.		sw	e	m	r	
1790-06	M6	10	11.5	9	9	5
1790-08	M8	13	15	12	12	9
1790-10	M10	17	19.6	15	15	20
1790-12	M12	19	21.9	18	17	25
1790-14	M14	22	25.4	21	20	40
1790-16	M16	24	27.7	24	22	55
1790-18	M18	27	31.2	27	24	80
1790-20	M20	30	34.6	30	27	110
1790-22	M22	32	36.9	33	30	130
1790-24	M24	36	41.5	36	32	190
1790-30	M30	46	53.1	45	41	400
1790-36	M36	55	63.5	54	50	680
1790-42	M42	65	75	63	58	1150

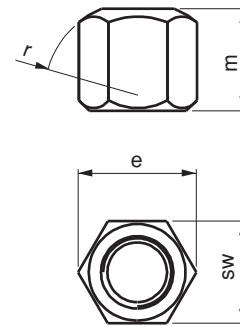

DIN 6330B
1790

- bei flachen Oberflächen verwendbar mit Scheibe DIN 6340
- bei Radius-Oberflächen verwendbar mit Scheiben DIN 6319D und DIN 6319G
- Gehärtet
- Schwarz beschichtet
- Qualität 10.

1790

- Flat surface is used with DIN 6340 Washer
- This nut is used with Rad-top surface DIN 6319D and DIN 6319G washers
- Hardened
- Black Coating
- Quality 10

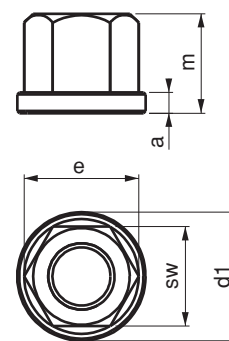
Referenz-Nr. Order No.		sw	e	m	a	d1	
1810-08	M8	13	14.7	12	3.5	18	12
1810-10	M10	17	19.2	15	4	22	25
1810-12	M12	19	21.5	18	4	25	30
1810-14	M14	22	24.9	21	4.5	28	50
1810-16	M16	24	27.2	24	5	31	65
1810-18	M18	27	30.6	27	5	34	90
1810-20	M20	30	34	30	6	37	130
1810-22	M22	32	36.3	33	6	40	155
1810-24	M24	36	40.8	36	6	45	220
1810-30	M30	46	52.3	45	8	58	465
1810-36	M36	55	62	54	10	68	500
1810-42	M42	65	75	63	12	80	1340

Sechskantmutter mit Bund
 Nut with Washer

DIN 6331
1810

- Gehärtet
- Schwarz beschichtet
- Qualität 10.

1810

- Hardened
- Black Coating
- Quality 10

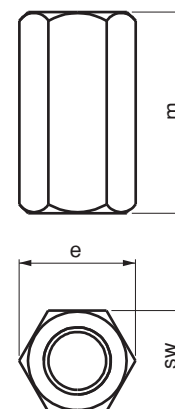
Referenz-Nr. Order No.		sw	e	m	
1830-06	M6	10	11.7	18	8
1830-08	M8	13	15	24	19
1830-10	M10	17	19.6	30	40
1830-12	M12	19	21.6	36	55
1830-14	M14	22	25.4	42	90
1830-16	M16	24	27.7	48	115
1830-18	M18	27	31.2	54	165
1830-20	M20	30	34.6	60	230
1830-22	M22	32	36.9	66	245
1830-24	M24	36	41.5	72	400
1830-30	M30	46	53.1	90	840
1830-36	M36	55	63.5	108	1430
1830-42	M42	65	75	126	2330

Verlängerungsmutter
 Extension Nut

DIN 6334
Ürün Nr. 1830 Uzatma Somun

- Verwendung zur Verlängerung von Stift-/Schrauben für T-Nuten DIN 787 / DIN 6379
- Gehärtet
- Schwarz beschichtet
- Qualität 10.

Product Nr. 1830 Extension Nut

- It is used in DIN 787 T-Studs and DIN 6379 Straight Studs as extension
- Hardened
- Black Coating
- Quality 10

Referenz-Nr. Order No.	Gewinde metric	a	d1	e	m	sw	
1840-16	M16	11.5	34	30.7	27.5	27	105
1840-20	M20	14	44	38.8	33	34	210
1840-24	M24	18.5	50.4	46	35	41	365



1840

- Ermöglicht schnelles Gleiten bei langen Gewinden, mit Mutter in geöffneten Position.
- Gehärtet
- Verzinkt
- Qualität 10.

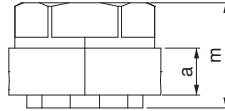

1840

- Enables fast sliding on long threads, with nut at open position.
- Hardened
- Zinc Coating
- Quality 10

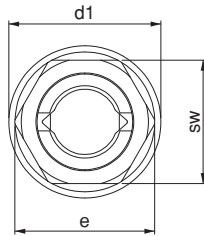

Sechskantmutterereinheit mit beweglichem Kopf

Ball Head Nut

Referenz-Nr. Order No.		sw	d1	m	
1850-08	M8	13	17	14	10
1850-10	M10	17	21	18	30
1850-12	M12	19	24	22	40
1850-16	M16	24	30	28	70
1850-20	M20	30	36	35	140
1850-24	M24	36	44	43	260

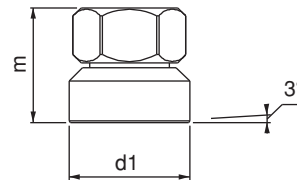

1850

- Vorteil bei winkligen Auflageflächen durch bewegliche Eigenschaft
- Gehärtet
- Schwarz beschichtet
- Qualität 10.

1850

- It provides advantage for using on angled surfaces due to the movement of the washer within itself
- Hardened
- Black Coating
- Quality 10

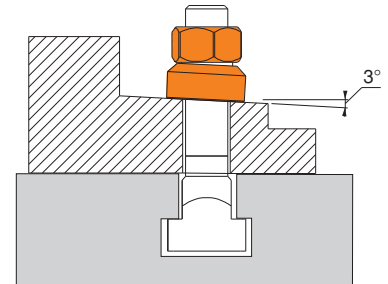
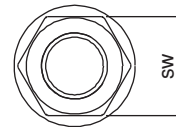

Referenz-Nr. Order No.	Gewinde metric	Zollgewinde whitworth	d1	d2	s	
1870-06	M6	1/4	6.4	17	3	6
1870-08	M8	5/16	8.4	23	4	10
1870-10	M10	3/8	10.5	28	4	16
1870-12	M12	1/2	13	35	5	30
1870-14	M14	-	15	40	5	40
1870-16	M16	5/8	17	45	6	60
1870-18	M18	-	19	45	6	60
1870-20	M20	3/4	21	50	6	70
1870-22	M22	7/8	23	50	8	90
1870-24	M24	7/8	25	60	8	140
1870-30	M30	1 1/8	31	68	10	215
1870-36	M36	1 1/4	38	80	12	360
1870-42	M42	1 1/2	44	98	15	640

DIN 6340 1870

- Gehärtet
- Schwarz beschichtet

DIN 6340 1870

- Hardened
- Black Coating

Scheibe

Washer

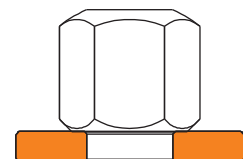
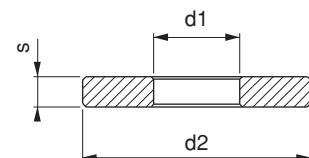

Referenz-Nr. Order No.		d1	d3	h2	r	
1890-06	M6	6.4	12	2.3	9	1.5
1890-08	M8	8.4	17	3.2	12	2.5
1890-10	M10	10.5	21	4.0	15	5
1890-12	M12	13	24	4.6	17	7
1890-14	M14	15	28	5.0	22	10
1890-16	M16	17	30	5.3	22	15
1890-20	M20	21	36	6.3	27	20
1890-24	M24	25	44	8.2	32	40
1890-30	M30	31	56	11.2	41	95
1890-36	M36	37	68	14.0	50	190
1890-42	M42	43	78	17.0	58	297

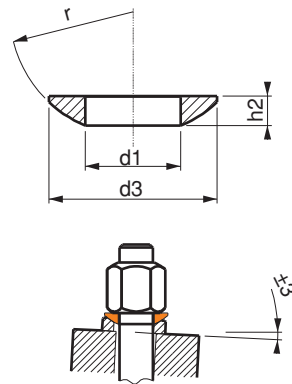

DIN 6319C

1890

- kompatibel mit Scheiben DIN 6319D und DIN 6319G auf winkelförmigen Flächen
- Gehärtet
- Schwarz beschichtet

1890

- This washer is used with DIN 6319G washers on angled surfaces
- Hardened
- Black Coating

Kegelscheibe / Kegelpfanne

Graded Washer

Referenz-Nr. Order No.		max. KN	d2	d4	h3	
1910-06	M6	9	7.1	12	2.8	2
1910-08	M8	17	9.6	17	3.5	4
1910-10	M10	26	12	21	4.2	6.5
1910-12	M12	38	14.2	24	5	10
1910-14	M14	53	16.5	28	5.6	10
1910-16	M16	73	19	30	6.2	15
1910-20	M20	117	23.2	36	7.5	25
1910-24	M24	168	28	44	9.5	55
1910-30	M30	269	35	56	12	120
1910-36	M36	394	42	68	15	220
1910-42	M42	542	49	78	18	365

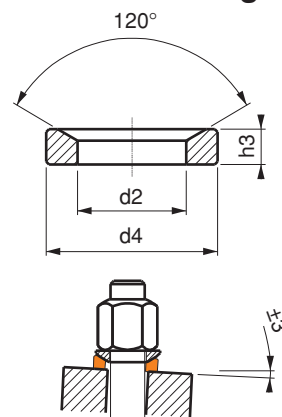

DIN 6319D

1910

- verwendbar mit Kugelscheibe DIN6319C auf winkelförmigen Flächen
- Gehärtet
- Schwarz beschichtet

1910

- This washer is used with DIN 6319C rad-top washers on angled surfaces
- Hardened
- Black Coating

Kegelscheibe / Kegelpfanne

Graded Washer

Referenz-Nr. Order No.		d2	d4	h3	
1930-06	M6	7.1	17	4	5.5
1930-08	M8	9.6	24	5	13
1930-10	M10	12	30	5	19
1930-12	M12	14.2	36	6	32
1930-14	M14	16.5	40	6	45
1930-16	M16	19	44	7	65
1930-20	M20	23.2	50	8	90
1930-24	M24	28	59	10	150
1930-30	M30	35	68	10	180
1930-36	M36	42	79	12	285
1930-42	M42	49	100	15	640

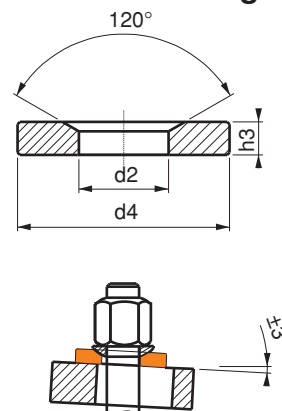

DIN 6319G



1930

- verwendbar mit Kugelscheibe DIN6319C auf winkelförmigen Flächen
- im Vergleich zu 6319D verwendbar bei größeren Löchern
- Gehärtet
- Schwarz beschichtet

1930

- This washer is used with DIN 6319C rad-top washers on angled surfaces
- According to DIN 6319D, it is used in the holes with bigger diameter
- Hardened
- Black Coating



Referenz-Nr. Order No.		
1950-1214	12-14	25
1950-1618	16-18	45
1950-2022	20-22	45
1950-2428	24-28	70



1950

- zur Reinigung von T-Nuten

1950

- This scraper is used to clean T-Slots

T-Nut Abdeckung

Milling T-Slot Cover

Referenz-Nr. Order No.	Breite Width (mm)	Länge Length (mm)	Anzahl Quantity
1955-T010	10	300	6
1955-T012	12	400	6
1955-T014	14	400	6
1955-T016	16	400	6
1955-T018	18	450	6
1955-T181	18	1000	5
1955-T205	20	500	10
1955-T020	20	1000	5
1955-T022	22	1000	5
1955-T024	24	1000	5
1955-T028	28	1000	5
1955-T036	36	1000	5



1955

- Es verhindert, dass unnötige Späne abfließen und verschmutzen.
Es wird zur Reinigung von T-Nuten verwendet.
- Material: Aluminium

1955

- It prevents unnecessary shavings filling and become dirty.
It is used to clean T-Slots.
- Material: Aluminum



Referenz-Nr. Order No.		
1960-110	14-16-18-20	1160

- 1960**
- Gehärtet
 - Schwarz beschichtet

Es bietet die Möglichkeit, das Werkstück an einer geeigneten Stelle der Platte während des nichtproportionalen Anschlags des Werkstücks zu befestigen.



- 1960**
- Hardened
 - Black coating

It provides convenience to fix the work piece on a suitable place of the plate during the non-proportional stopping of the work piece to be applied on the plate of the bench

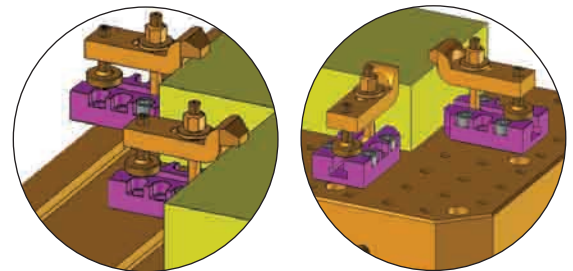
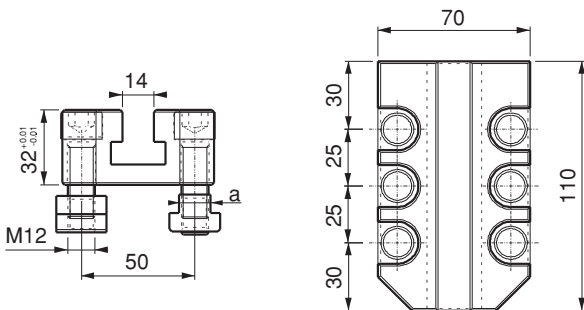

Spanneisenhalter federnd

for Lifting the Washer

Referenz-Nr. Order No.		Ø D	Ø d	L	L1	
1970-10	M10	27	10.5	35	20	65
1970-12	M12	27	12.5	40	33	70
1970-14	M14	28	14.5	40	30	60
1970-16	M16	37	16.5	45	30	110
1970-18	M18	37	18.5	45	40	115
1970-20	M20	37	21	45	42	105
1970-22	M22	37	23	45	45	120
1970-24	M24	45	25	50	45	170

- 1970**
- Arbeitserleichterung durch Stützen bei Werkstückaufnahme bzw. -abnahme
 - Schnelles und sicheres Entspannen wird gewährleistet.
 - Schwarz beschichtet

- 1970**
- This washer provides convenience of using in coupling and dismantling processes by lifting the clamp evenly
 - Black coating

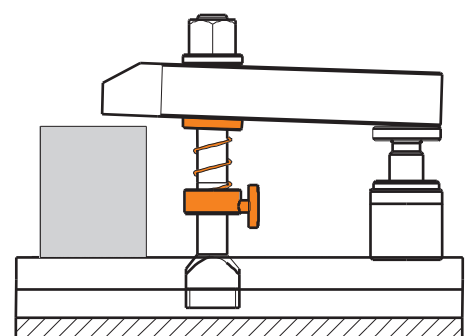
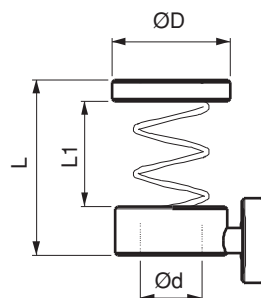

Sets

Sets



Referenz-Nr. Order No.			 (kg)	d x L DIN 6379
1990-1012	M10x12	265x255	6.44	M10x80-100-160-200
1990-1214	M12x14	305x255	8.72	M12x80-100-160-200
1990-1416	M14x16	435-255	12.98	M14x80-100-160-200
1990-1618	M16x18	435-255	16.30	M16x80-100-160-200
1990-1820	M18x20	495x255	17.82	M18x80-100-160-200
1990-2022	M20x22	540x255	23.10	M20x100-125-160-200

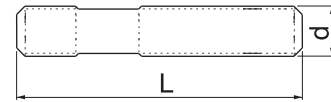

1990

• Dies ist ein aus Stahl hergestellte Spannelemente-Satz, um das Werkstück oder die Vorrichtungen schnell und sicher auf dem Tisch zu spannen.

1990

• This is the coupling set produced from steel product in order to couple the work piece or apparatuses on the table in a rapid and safe way.

Nr.	L	b1		a	e2	b2
1330	80	11	M10	15	30	30
1330	100	14.5	M12-M14	20	40	40
1330	125					
1330	125	18.5	M16-M18	25	45	50
1330	160					
1330	160	22.5	M20-M22	30	60	60
1330	200					

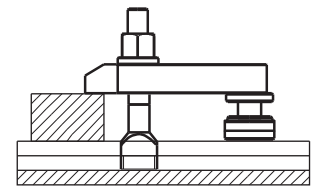
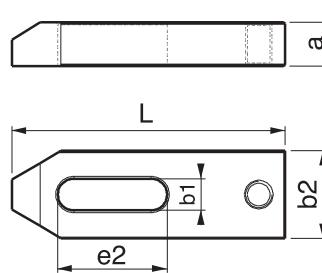

	DIN 508	DIN 6330 B	Nr 1830	DIN 6331	DIN 6340
12	M10	M10	M10	M10	M10
14	M12	M12	M12	M12	M12
16	M14	M14	M14	M14	M14
18	M16	M16	M16	M16	M16
20	M18	M18	M18	M18	M18
22	M20	M20	M20	M20	M20

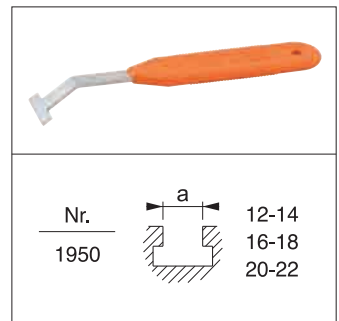

Nr.	h	H	d	D
1510	23	30	M16	34
1510	40	60	M16	34
1510	70	100	Tr 30x4	50
1510	100	140	Tr 30x4	50

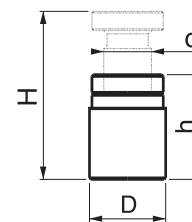





Set-Inhalt

- 6 St T-Backen DIN 508 (M20x22 4 St)
- 16 St Bolzen DIN 6379
- 6 St Mutter DIN 6330B
- 4 St Mutter mit Scheibe DIN 6331
- 2 St Verlängerungsmutter Nr. 1830
- 4 St Scheibe DIN 6340
- 4 St. Backen Nr. 1330
- 8 St. Höhen-Richtsraubstock Nr. 1510
- 1 St. Nutenräumer 1950
- 1 St Stahlset lackiert
- Hinweis : 1990-2022= 6kt-Mutter und Scheibe = 4 St
- 1990-1012 und 1990-1214= 6 St. Höhen-Richtsraubstock 1510

Product: 52 piece set

- 6 pieces of DIN 508 T-Nut (M20x22 4 piece)
- 16 pieces of DIN 6379 Stud
- 6 pieces of DIN 6330B Supported Nut
- 4 pieces of DIN 6331 Nut with Washer
- 2 pieces of No. 1830 Extension Nut
- 4 pieces of DIN 6340 Thick Washer
- 4 pieces of No. 1330 Clamp with Support Hole
- 8 pieces of No. 1510 Screw Thread Lifter Support
- 1 piece of No. 1950 T-Slot Scraper
- 1 piece of Steel Set with Statical Paint
- Note: 1990-2022= Hexagon nut and washer = 4 pcs
- 1990-1012 and 1990-1214= 1510 support 6 pcs

Referenz-Nr. Order No.	 dx		 (kg)	DIN 6379 d x L 
2010-1012	M10x12	330x255	7.27	M10x80-100-160-200
2010-1214	M12x14	380x255	9.26	M12x80-100-160-200
2010-1416	M14x16	435x255	12.29	M14x80-100-160-200
2010-1618	M16x18	435x255	15.62	M16x80-100-160-200
2010-1820	M18x20	495x255	18.00	M18x80-100-160-200



2010



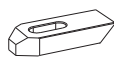

- Dies ist ein aus Stahl hergestellte Spannelemente-Satz, um das Werkstück oder die Vorrichtungen schnell und sicher auf dem Tisch zu spannen.

2010

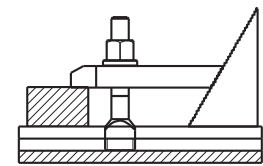
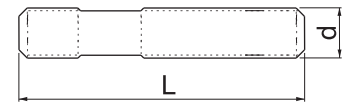
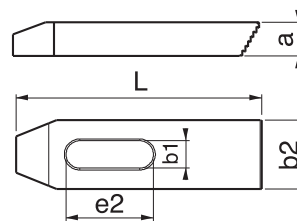
- This is the coupling set produced from steel product in order to couple the work piece or apparatuses on the table in a rapid and safe way.

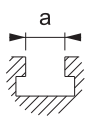
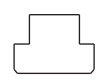
Nr.	L	b1		a	e2	b2
1290	80 100	11	M10	15	30 45	30
1290	100 125	14.5	M12-M14	20	45 55	40
1290	125 160	185	M16-M18	25	65 65	50

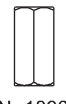

 a	 DIN 508	 DIN 6330 B	 Nr 1830	 DIN 6331	 DIN 6340
12	M10	M10	M10	M10	M10
14	M12	M12	M12	M12	M12
16	M14	M14	M14	M14	M14
18	M16	M16	M16	M16	M16
20	M18	M18	M18	M18	M18

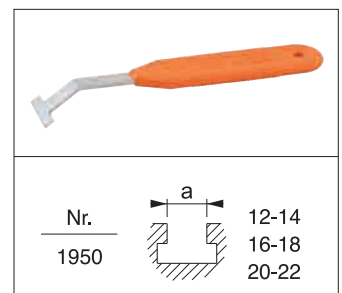

Nr.	h-H	a	min-max
1310	37-85	57	0-40
1310	48-112	73	0-60
1310	58-139	90	0-75
1310	66-165	108	0-90

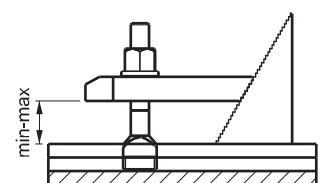
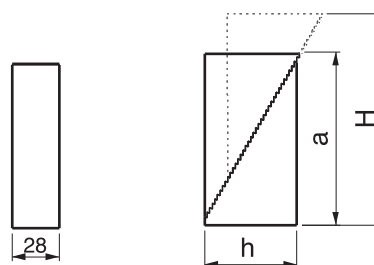

Set-Inhalt

- 6 St T-Backen DIN 508 (M20x22 4 St)
- 16 St Bolzen DIN 6379
- 6 St Mutter DIN 6330B
- 4 St Mutter mit Scheibe DIN 6331
- 2 St Verlängerungsmutter Nr. 1830
- 4 St Scheibe DIN 6340
- 4 St Spanneisen mit Treppenzähnen Nr. 1290
- 8 St Spannunterlagen mit Treppenzähnen Nr. 1310
- 1 St. Nutenräumer 1950
- 1 St Stahlset lackiert

Product: 52 piece set

- 6 pieces of DIN 508 T-Nut (M20x22 4 piece)
- 16 pieces of DIN 6379 Stud
- 6 pieces of DIN 6330B Supported Nut
- 4 pieces of DIN 6331 Nut with Washer
- 2 pieces of No. 1830 Extension Nut
- 4 pieces of DIN 6340 Thick Washer
- 4 pieces of No. 1290 Serrated Clamp
- 8 pieces of No. 1310 Clamp with Support Hole
- 1 piece of No. 1950 T-Slot Scraper
- 1 piece of Steel Set with Statical Paint

Referenz-Nr. Order No.			Sikma kuvveti Clamping force kgf	L	m	n	
2020-120125	M12	14-16-18	1500	125	20	15	1414
2020-120250	M12		1500	250	20	15	1528
2020-120500	M12		1500	500	20	15	1755
2020-121000	M12		1500	1000	20	15	2210
2020-160125	M16	18-20-22-24	4000	125	33	21	3495
2020-160250	M16		4000	250	33	21	3810
2020-160500	M16		4000	500	33	21	4480
2020-161000	M16		4000	1000	33	21	5820

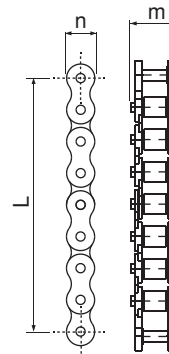
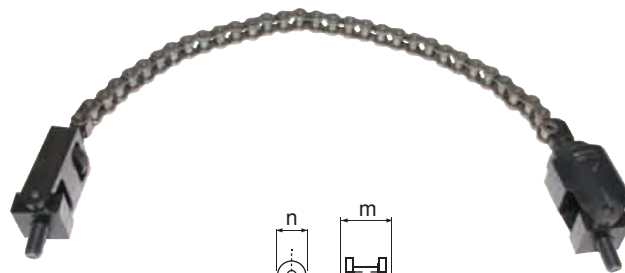

2020

- konstruiert für zylindrische und ovale Werkstücke
- Gehärtet
- Schwarz beschichtet

2020

- It is designed for clamping of cylinder and oval workpieces.
- Hardened
- Black coated

Referenz-Nr. Order No.		a	b	c	e1	f1	h1 min.	h1 max.	m	s1	Sikma kuvveti Clamping force kgf	
2020-12125	14-16-18	36	36	18	49	21	95	125	M12	35	1500	580
2020-16162	18-20-22-24	37	44	25	64	29	117	162	M16	45	4000	1275

Verstelleinheit

Setting Unit

2020

- Gehärtet
- Schwarz beschichtet

2020

- Hardened
- Black coated

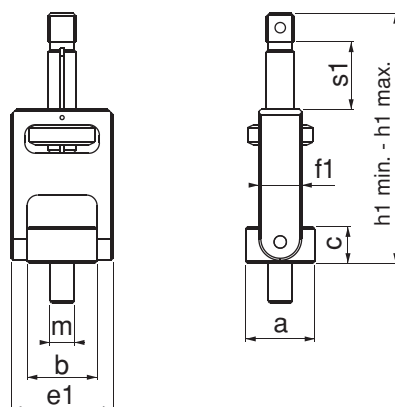

Referenz-Nr. Order No.		a	b	c	e2	f2	h2 min.	h2 max.	s2	SW	m	Spannkraft clamping force kgf	
2020-12127	14-16-18	36	36	18	54	49	111	127	16	36	M12	1500	945
2020-16170	18-20-22-24	37	44	25	70	62	140	170	30	46	M16	4000	1890

Hakeneinheit

Hook Unit

2020

- Gehärtet
- Schwarz beschichtet

2020

- Hardened
- Black coated

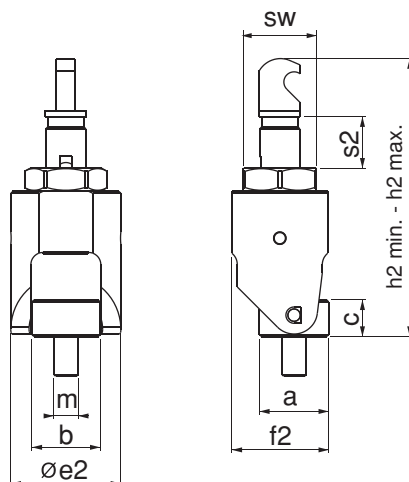

Seitenspanner

Side Clamps



Referenz-Nr. Order No.		c	L	b	n	k	k1	k2	L1	d	d1	d2	sw	Spannkraft clamping force kgf	Drehmoment Allowable Screw Torque (N-m)	 (g)
2030-14	14	5	90	23	47	47	26	26	65	M12	M12	M12	10	2000	35	3490
2030-16	16															3670
2030-18	18															5000
2030-20	20															5355
2030-22	22															5720
2030-24	24															6190
2030-28	28															6650



2030

- Wenn das Produkt das Werkstück in spannt, führt dies nicht zu einer Veränderung der ursprünglichen Form des Werkstücks.
- Gehärtet
- Schwarz beschichtet
- Set in Plastikbox

2030

- When the product clamps the work piece in the direction of rest, it does not cause alteration in the genuine structure of the piece.
- Hardened
- Black coating
- Set is in the plastic box

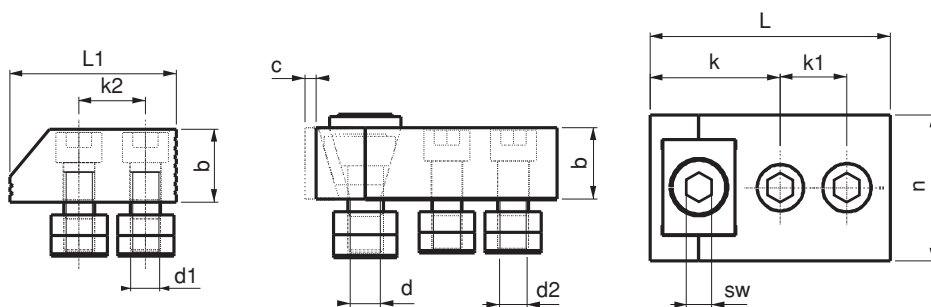

Set-Inhalt / The set consists of						
Teil Part						
Menge Quantity	2	2	10	10	1	1

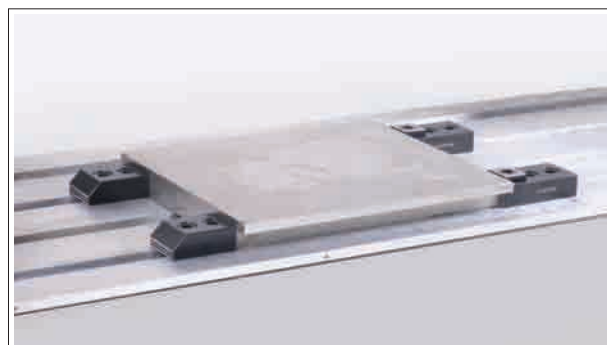

Referenz-Nr. Order No.		c	L	L1	L2	L3	b	b1 ±0.01	n	k	k1	k2	d	d1	d2	sw	Spannkraft clamping force Kgf	Drehmoment Allowable Screw Torque (N-m)	 (g)
2050-14	14	5	110	90	85	65	41	18	47	47	26	26	M12	M12	M12	6	1000	15	5920
2050-16	16																		6210
2050-18	18																		8090
2050-20	20																		8440
2050-22	22																		8825
2050-24	24	10080																	
2050-28	28	10750																	



2050

- Wenn das Produkt das Werkstück in spannt, führt dies nicht zu einer Veränderung der ursprünglichen Form des Werkstücks. Aufgrund der Parallelität kann der Bohrprozess auf das bearbeitete Teil angewendet werden.
- Gehärtet
- Schwarz beschichtet
- Set in Plastikbox

2050

- When the product clamps the work piece in the direction of rest, it does not cause alteration in the genuine structure of the piece. Because of being with parallel, hole process can be applied on the machined piece.
- Hardened
- Black coating
- Set is in the plastic box

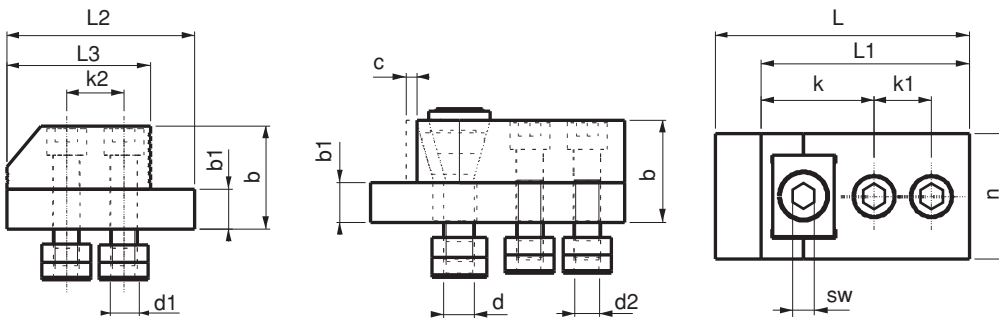

Set-Inhalt / The set consists of						
Teil Part						
Menge Quantity	2	2	10	10	2	1

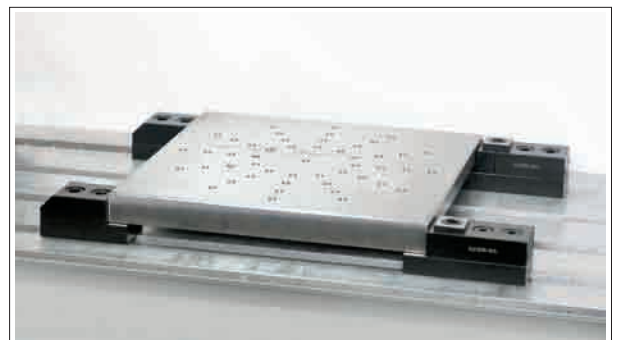

Referenz-Nr. Order No.		c	L	b	b1	n	n1	n2	k	k1	k2	sw	i	h	h1	d	d1	sıkma kuvveti clamping force Kgf	Tork Değeri Allowable Screw Torque (N-m)	 (g)
2070-14	14	10	142	24	8	37	12.5	18.5	65	54	26	6	65	23	10	M12	M12	850	15	3575
2070-16	16																			3710
2070-18	18																			5215
2070-20	20	14	145	28	10	48	12.5	18.5	74	56	26	8	65	28	11	M12	M12	1000	35	5400
2070-22	22																			5610

2070

- Durch die Gleitstruktur der beweglichen Backe spannt sie das Werkstück in Richtung Auflage und Platte. Die breite Bewegung der Backe bietet Komfort beim Spannen und Entspannen des Werkstücks.
- geeignet für T-Nut DIN 650
- Gehärtete Backen
- Schwarz beschichtet
- Set in Plastikbox

2070

- Because of the sliding structure of the moving jaw it clamps the work piece in the direction of resting and plate. Wide movement of the jaw provides convenience in coupling and dismantling of the workpiece.
- It is in compliance with DIN 650 T-Slot
- Hardness of jaw: Hardened
- Black coating
- Set is in the plastic box

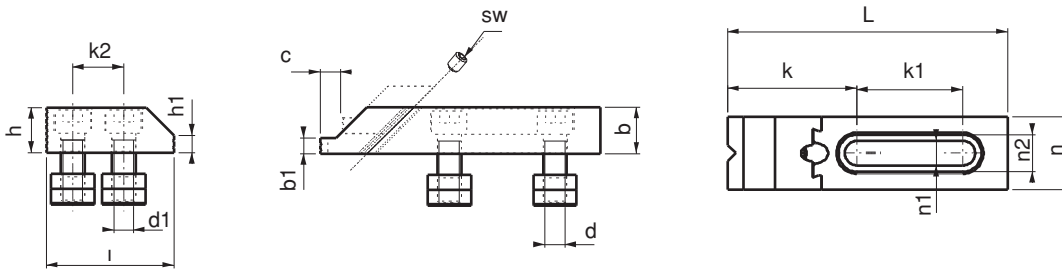

Set-Inhalt / The set consists of						
Teil Part						
Menge Quantity	2	2	8	8	2	1

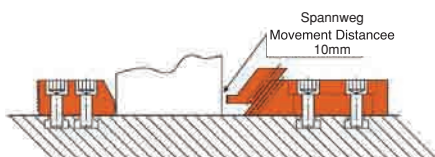
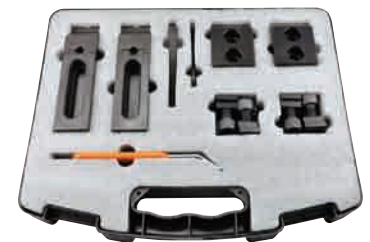

Die Winkelauflagefläche ist für dünne Werkstücke und die gerade Fläche für dicke Werkstücke.

Note: Fixed rest can be used as two different ways: Graded side is used for thin pieces and the Straight side is used with thick pieces.



Referenz-Nr. Order No.	A	B	C	D	E	F	G	H	J	K	L	M	Spannkraft Clamping Force Kgf	Drehmoment Allowable Screw Torque (N-m)	 (g)
2072-08016	39.5	65	7.5	25	45	16	7	1.5	7	4	M8	25	400	8	160
2072-12022	60	85	10	40	60	22	12	2	9	6	M12	35	900	26	450
2072-16030	77	100	14	50	70	30	14	2	13	8	M16	40	1700	60	900

2072

- Schwarz beschichtet

2072

- Black Coating

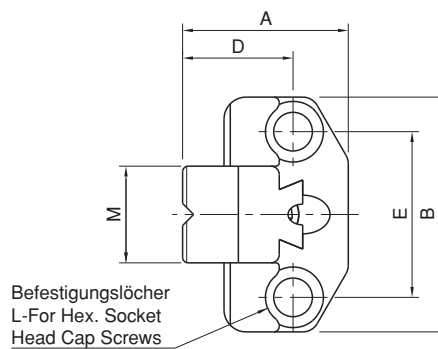
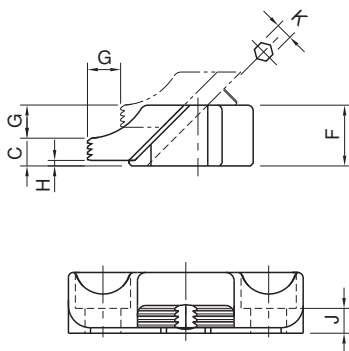

Seitenspannbacke

Side Clamps

Referenz-Nr. Order No.	A	B	C	D	E	F	G	H	J	K	L	M	Spannkraft Clamping Force Kgf	Drehmoment Allowable Screw Torque (N-m)	 (g)
2073-08016	39.5	65	19.5	25	45	16	7	1.5	7	4	M8	25	400	8	180
2073-12022	60	85	29	40	60	22	12	2	9	6	M12	35	900	26	500
2073-16030	77	100	38	50	70	30	14	2	13	8	M16	40	1700	60	1010

2073

- Gehärtete Backen
- Schwarz beschichtet

2073

- Hardness of jaw: Hardened
- Black Coating

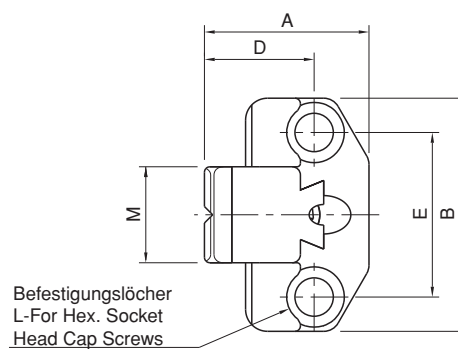
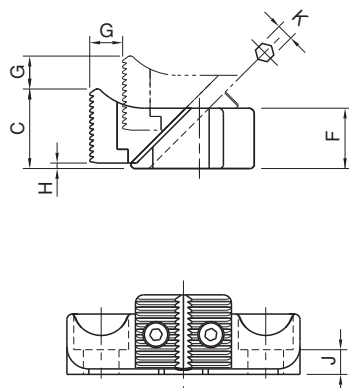

Referenz-Nr. / Order No.	A	B	C	D	E	F	G	H	J	K	L	M	N
2077-08001	44	32	20	8	28.5	4	26.5	23	7	15	19	10	M8x1.25
2077-10001	54	40	25	10	35	5	33	29	9	16	24	12	M10x1.5
2077-12001	62	46	30	12	39.5	5.5	37.5	35	11	17	27	14	M12x1.75

Referenz-Nr. / Order No.	P	Spannkraft Clamping Force Kgf	Drehmoment Allowable Screw Torque (N-m)	
2077-08001	6	350	45	160
2077-10001	8	550	55	310
2077-12001	10	700	70	490



2077

• Schwarz beschichtet

2077

• Black Coating

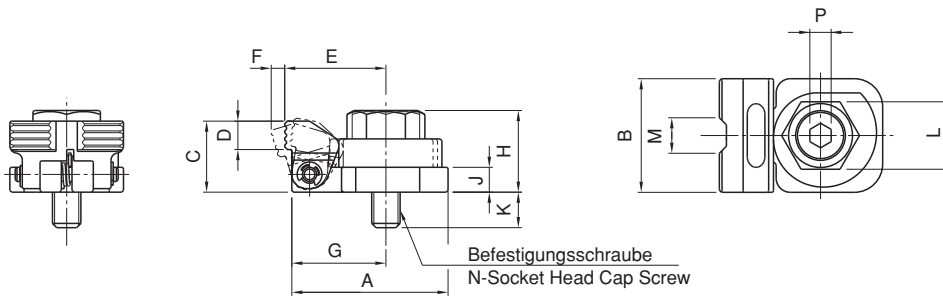

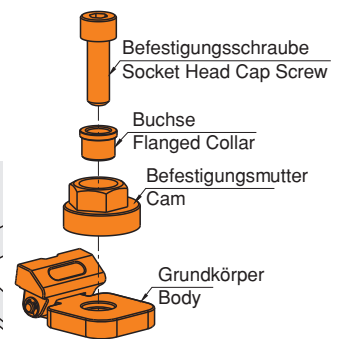
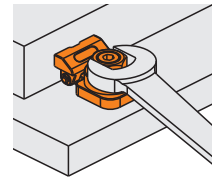

Verwendung / How To Use

- Zuerst die Seitenspannbacke platzieren und dann mit einem Schraubenschlüssel spannen.
- Secure the body and the flanged collar with a socket head cap screw, and then turn the the cam with a wrench to clamp a workpiece.



Seitenspannbacke

Side Clamps

Referenz-Nr. / Order No.		A	H	L	S	Spannkraft Clamping Force Kgf	
2080-01428	14 - 16 - 18 - 20 - 22 - 24 - 28	61	57	108	5	1500	1850

2080

• Spannen horizontal und vertikal möglich

Körper

• Statische Lackierung

Backe

• Gehärtet

2080

• Vertical down thrust and horizontal clamping force available simultaneously with the operation of leverage screw

Body

• Statical Painting

Jaw

• Hardened

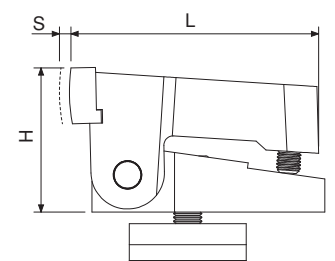
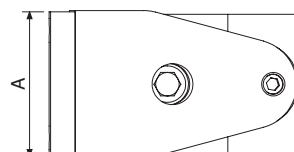
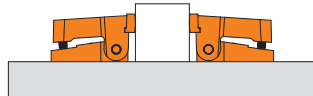
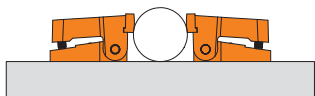

Referenz-Nr. Order No.		c	b	k1	k2	k3	k4	L	h	h1	d	d1	Spannkraft clamping force kgf	 (g)
2090-14	14	3.5	30	95	99	26	26	65	28	10	M12	M12	3500	7925
2090-16	16													8490
2090-18	18													4610
2090-20	20													8850
2090-22	22													9030
2090-24	24													9490
2090-28	28													9800



2090

- Ürünün eksantrik çalışma sistemi saat yönünde sıkıldığında iş parçasını dayama ve pleyt yönüne özel dizayn anahtarı ile yüksek kuvvette sıkar.

1. Spannweite 3,5 mm
 2. Werkstückdistanz bis 1,5-2 mm
 3. Befestigung mit 10 mm Allen und Inbusschraube
 4. Befestigung des Werkstücks durch Drehen im Uhrzeigersinn
- geeignet für T-Nut DIN 650
 - Mutter: gehartet
 - Schwarz beschichtet
 - Set in Plastikbox

2090

- When the eccentric working system of the product is tightened clockwise, it clamps the work piece with high force in the direction of resting and plate with it's special designed wrench.

- 1-Eccentric movement of Armed Side Clamp 3.5 mm.
 - 2-It brings the product 1.5 - 2mm close to the work piece
 - 3-imbus bolts are fixed with 10mm allen.
 - 4-Fixing of the work piece is implemented by turning the product clockwise with the wrench.
- It is in compliance with DIN 650 T-Slot
 - Hardness of nut: Hardened
 - Black coating
 - Set is in the plastic box

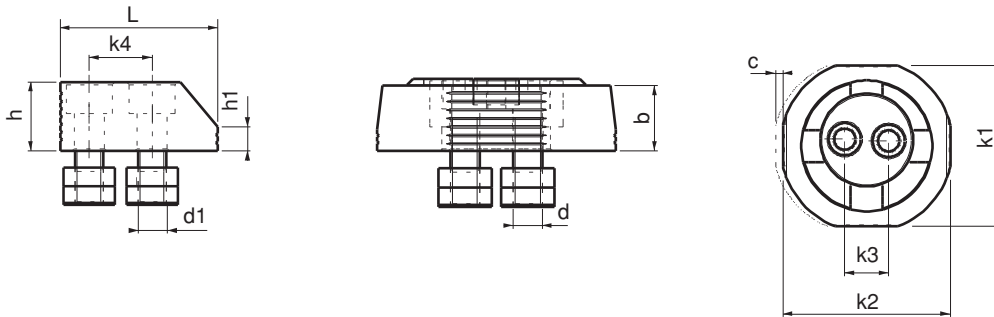

Set-Inhalt / The set consists of							
Teil Part							
Menge Quantity	2	2	1	8	8	1	1

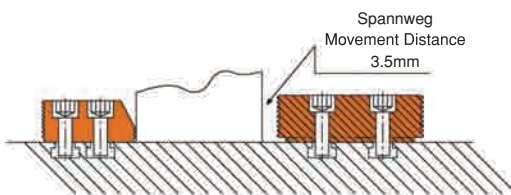

Die Winkelaufschlagfläche ist für dünne Werkstücke und die gerade Fläche für dicke Werkstücke.
Note: Fixed rest can be used as two different ways: Graded side is used for thin pieces and the Straight side is used with thick pieces.



Referenz-Nr Order No.		a1	a2	b	b1	c	h min-max	L	SW	F1 Spannkraft clamping force kgf	F2 Spannkraft clamping force kgf	 (kg)
2095-571	14-16-18	37	37	57	19	8	78-98	185	10	2250	350	3.68
2095-761	20-22-24-28	37	45	76	26	11	98-118	240	14	3000	450	7.66

2095

- Er spannt die Werkstücke in Spannauflagen- und Plattenrichtung, er ist speziell für hohe Werkstücke ausgelegt.
- Gehärtete Backen
- Schwarz beschichtet

2095

- It clamps the workpieces in clamp rest direction and plate direction, it is designed especially for high workpieces.
- Hardness of jaw: Hardened
- Black coating

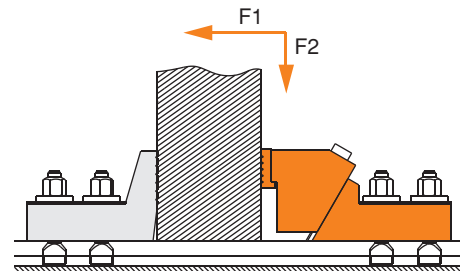
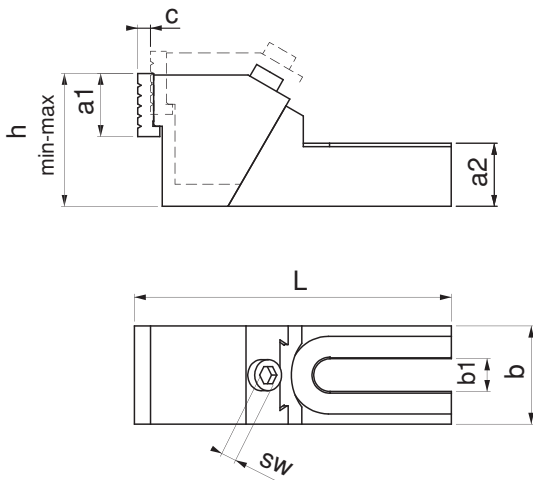

Stabilspannbacken

Referenz-Nr Order No.		a1	a2	b	b1	c	h min-max	L	SW	F1 Spannkraft clamping force kgf	F2 Spannkraft clamping force kgf	 (kg)
2095-572	14-16-18	37	37	57	19	8	78-98	185	10	2250	350	3.6
2095-762	20-22-24-28	37	45	76	26	11	98-118	240	14	3000	450	6.7



2095

- Er spannt die Werkstücke in Spannauflagen- und Plattenrichtung, er ist zum Spannen großer Platten ausgelegt.
- Gehärtete Backen
- Schwarz beschichtet

2095

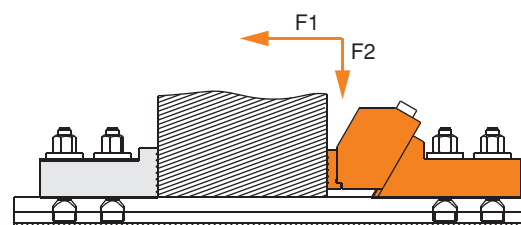
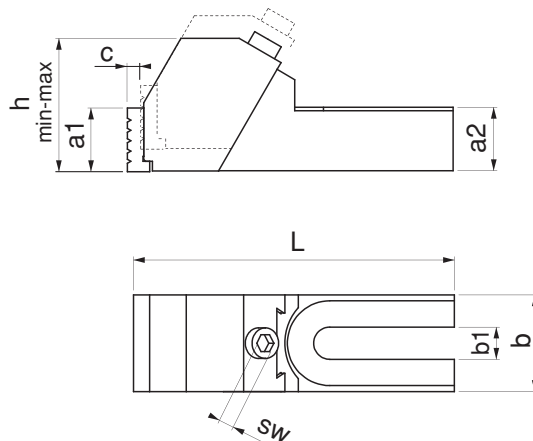
- It clamps the workpieces in clamp rest direction and plate direction, it is designed for clamping big plates.
- Hardness of jaw: Hardened
- Black coated



Referenz-Nr. Order No.		a2	b	b1	h	L	 (kg)
2098-571	14-16-18	37	57	19	85	124	2.025
2098-761	20-22-24-28	45	76	26	105	154	4.185

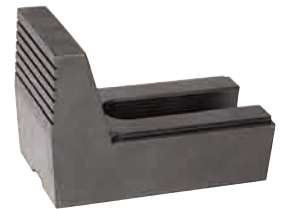

2098

- passend zu 2095-571 und 2095-761
- Schwarz beschichtet

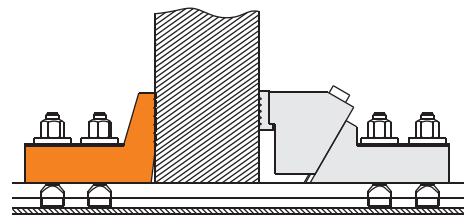
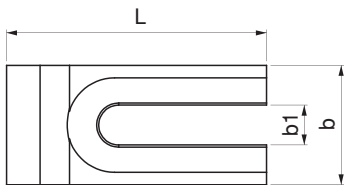
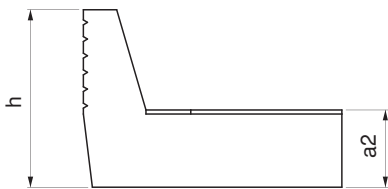

2098

- It is designed as clamp rest for clamps 2095-571 and 761.
- Black coating



Gegenhalter

Block Stopper Side Press

Referenz-Nr. Order No.		a2	b	b1	h	L	 (kg)
2098-572	14-16-18	37	57	19	47	112	2.800
2098-762	20-22-24-28	45	76	26	49	140	4.185



2098

- passend zu 2095-572 und 2095-762
- Schwarz beschichtet

2098

- It is designed as clamp rest for clamps 2095-572 and 762.
- Black coating

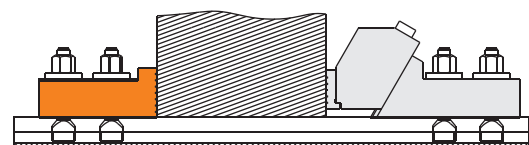
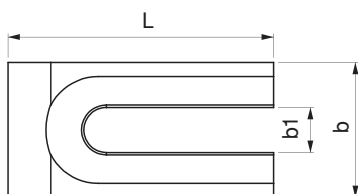

Referenz-Nr. Order No.		c	h	b	L	L1	L2	sw	d	Spannkraft Clamping Force		
										f1 Kgf	f2 Kgf	
2110-12	12	3	20	40	80	39	26	6	M10	1600	60	415
2110-14	14									2200	90	425
2110-16	16									3200	120	785
2110-18	18	4	25	50	100	46	34	8	M14	3600	140	810
2110-20	20									3600	140	850
2110-22	22									3600	140	2275
2110-24	24	5	28.5	78	140	65	50	10	M20	3600	140	2360
2110-28	28									4000	160	2500

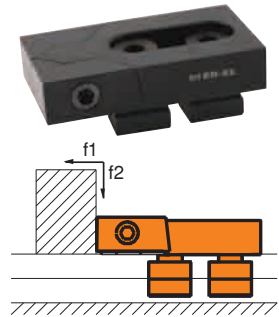

2110

- Das Produkt spannt das Werkstück in Spannauflagen- und Plattenrichtung. Durch die Struktur der Klemme wird eine kraftvolle Spannung erreicht.
- Gehärtet
- Schwarz beschichtet

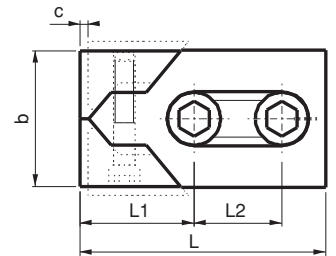
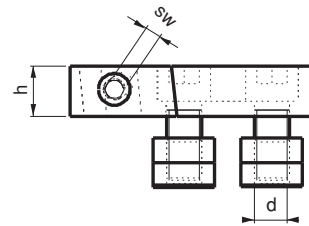

2110

- Product clamps the work piece in the direction of rest and plate. It achieves powerful clamping because of the clamp's structure.
- Hardened
- Black coating

Referenz-Nr. Order No.		a h6	b -0.6	c DIN 650	d ±0.01	h1 ±0.01	h1 ±0.02	h2	h3	ISO 4762	
2120-1450	14	0-0.011	14	24	32	-	50	9	8	M8x60	355
2120-1825	18	0-0.011	18	30	40	25	-	15	10	M10x40	360
2120-1850	18	0-0.011	18	30	40	-	50	15	10	M10x65	600
2120-2225	22	0-0.013	22	38	40	25	-	15	14	M10x50	410
2120-2250	22	0-0.013	22	38	40	-	50	15	14	M10x75	650

Anschlagstück
Cylinder Pluggable

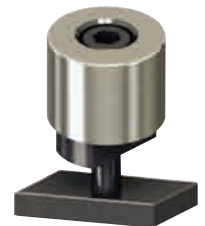

2120

- Gehärtet
- Schwarz beschichtet

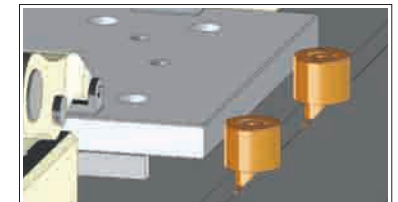
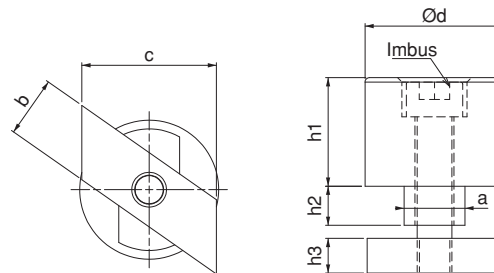

2120

- Hardened
- Black coating

Referenz-Nr. Order No.		n	e	c	d	b	h	k	L	sw	
2130-14	14	13.7	22	22	M8	11	4	8	44	6	180
2130-16	16	15.7	25	25	M12	12.5	5	9	50	10	270
2130-18	18	17.7	28	28	M12	14	5	10	56	10	355
2130-20	20	19.7	32	32	M16	16	5	12	64	14	570
2130-22	22	21.7	35	35	M16	17.5	6	14	70	14	770
2130-24	24	23.7	40	40	M20	20	6	16	80	17	1180
2130-28	28	27.7	44	44	M20	22	6	18	88	17	1560

Nutanschlag
Clamp Rest



2130

- Verwendung für Referenzen in der Länge/Breite
- Gehärtet
- Schwarz beschichtet

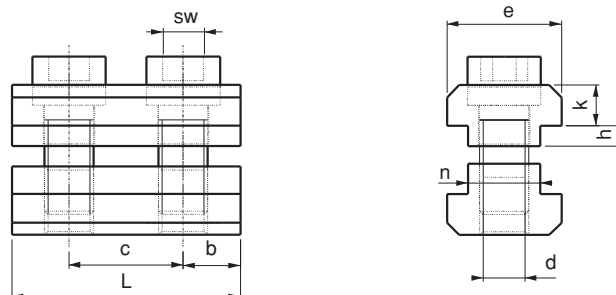

2130

- Clamp Rest is used for reference taking, longitudinal and cross-wise.
- Hardened
- Black coating

Referenz-Nr. Order No.	Verwendung ohne Anschlag In Use Without Slip Stopper		Verwendung mit Anschlag In Use With Slip Stopper		 (kg)
	Spannkraft Clamping Force Kgf	Drehmoment Allowable Screw Torque (N-m)	Spannkraft Clamping Force Kgf	Drehmoment Allowable Screw Torque (N-m)	
2135-1260	2900	38	6900	90	2.4

inkl. Schraub M12 und 4 Beilagscheiben
4 washers for M12 bolts are included.

2135

Grundkörper

- Material: Stahlguss
- Schwarz beschichtet

Backe

- Gehärtet
- Schwarz beschichtet

Schraube

- Gehärtet: Induktion
- Schwarz beschichtet

2135

Body

- Material: Cast Iron
- Black coating

Jaw

- Hardened
- Black coating

Bolt

- Hardness: Induction
- Black coating

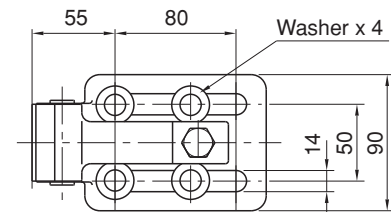
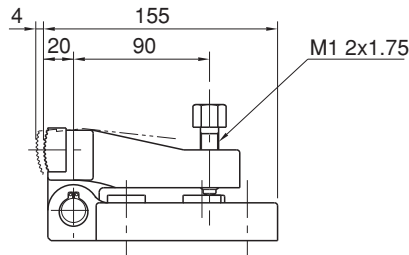
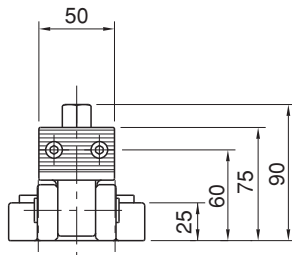

Seitenspannbacke

Referenz-Nr. Order No.	Spannkraft Clamping Force Kgf	Drehmoment Allowable Screw Torque (N-m)	 (kg)
2137-16060	5800	150	2.9

inkl. 2 Beilagscheiben für Schrauben M12 und M16
2 spherical washers for both M12 and M16 screws are included.

2137

Grundkörper

- Material: Stahlguss
- Schwarz beschichtet

Backe

- Gehärtet
- Schwarz beschichtet

Schraube

- Gehärtet: Induktion
- Schwarz beschichtet

2137

Body

- Material: Cast Iron
- Black coating

Jaw

- Hardened
- Black coating

Bolt

- Hardness: Induction
- Black coating

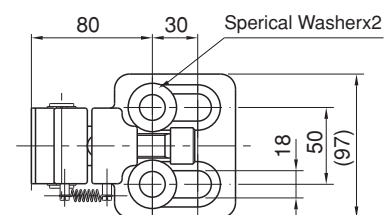
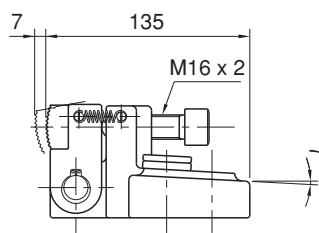
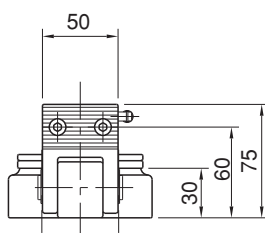

Referenz-Nr. Order No.	W1	W2	H1	H2	M	P1	H4	L4	W	L3	H5	d	L5	P
2139-32150	45	15	27	18	M4x0.7	30	18	13	75	20	8	6.6	3	60
2139-40200	60	20	33	22	M5x0.8	40	22	17	100	26	10	8.6	4	80

Referenz-Nr. Order No.	H	L	L2	R	L1	H3	M1
2139-32150	32	51	48	63	51.5	18	M4x0.7
2139-40200	40	67	63	80	67	22	M5x0.8

Referenz-Nr. Order No.	A	Spannhub Clamping Stroke	Betriebslast Operating Load (N)	Spannkraft Clamping Force Kgf	 (g)
2139-32150	19	1.6	150	200	620
2139-40200	24	2.2	200	300	1360



2139

• Schwarz beschichtet

2139

• Black coating

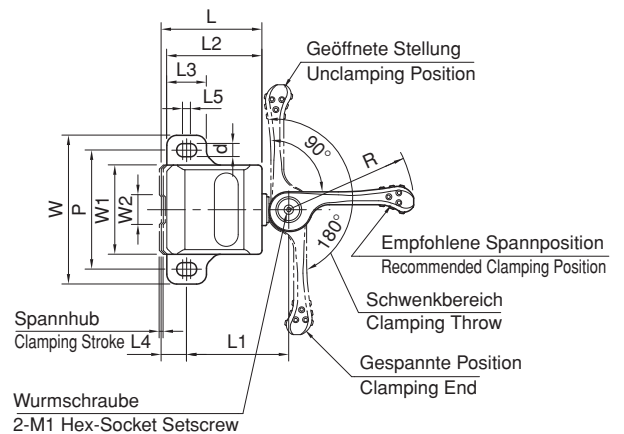
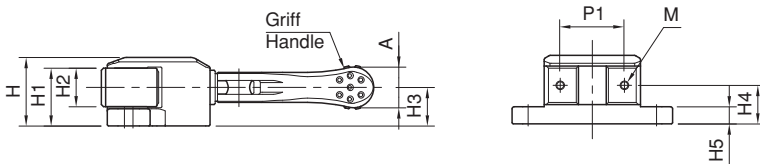

Eigenschaft

- Spannen mit Griff mit 1-Touch
- Perfektes Spannen bei Bearbeitung
- Perfekter Halt durch den Druck nach unten und nach vorne

Features

- The cam handle allows fast clamping in single operation.
- Precision-ground jaw is perfect for clamping the workpiece on its finished surface.
- In clamping, the jaw provides downward force to prevent part lift.



Wechsel der Griffposition

Griff mit 4 Optionen

Changing Handle Position

The handle shaft has 4 countersinks which are provided every 90° for 4 options of handle position

**Verwendung
How To Use**

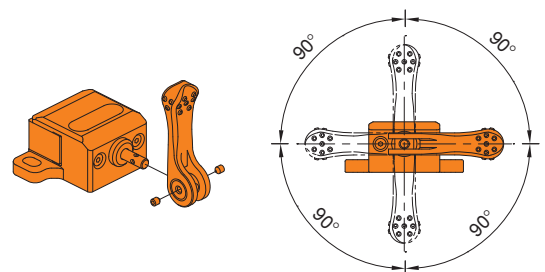
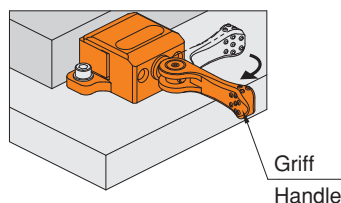

Referenz-Nr. Order No.	Spannhub Clamping Stroke	W1	W2	H3	H4	L2	W	L	H2	d	P	H5	L1
2141-00010	1	38	8	6	3	15	45	33.5	10	5.2	36	5	30.5
2141-00015	2	60	12	9	5	22	70	50	15	8.2	55	7	46

Referenz-Nr. Order No.	H	D	H1	R	A	W3	M1	zulässiges Drehmoment Allowable Screw Torque (N m)	Spannkraft Clamping Force Kgf	 (g)
2141-00010	30	13	20	63	12	6	M4x0.7	10	400	85
2141-00015	46	19	30	100	18	10	M5x0.8	27	600	290

2141

Grundkörper

- Schwarz beschichtet

Backe

- Gehärtet
- Schwarz beschichtet

2141

Body

- Black coating

Jaw

- Hardened
- Black coating

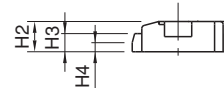
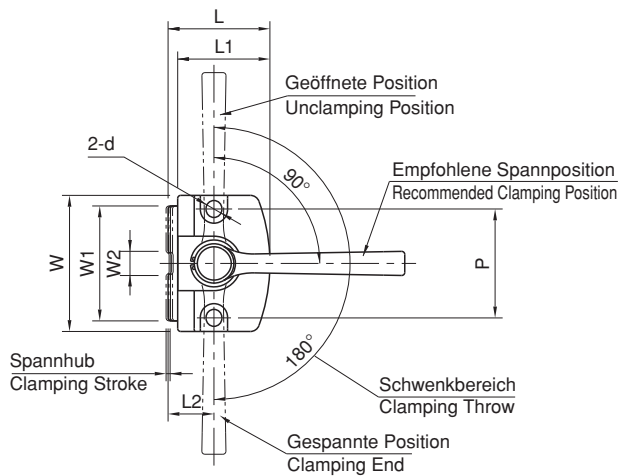

Verwendung / How To Use

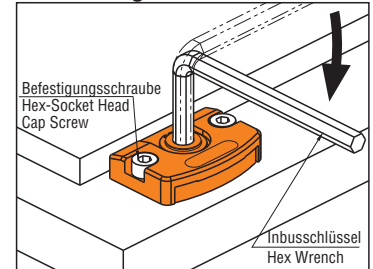

Seitenspannbacke

Referenz-Nr. Order No.	S	W	W1	H1	L1	P	D (h7)	H2	M	L	H	T	Spannkraft Clamping Force Kgf	Drehmoment Allowable Screw Torque (N-m)	 (g)
2143-08015	3	25	10	25	21.5	10	6	7	M8	32	15	1.6	700	25	115
2143-10019	4	30	11	32	26	12	6	7	M10	40	19	2	850	50	225
2143-12023	5	35	12	38	33	16	8	10	M12	50	23	2.3	2000	90	390
2143-16025	6	40	14	45	40	20	10	10	M16	60	25	3.2	3000	150	640



2143

- Gehärtet
- Schwarz beschichtet

2143

- Hardened
- Black coating

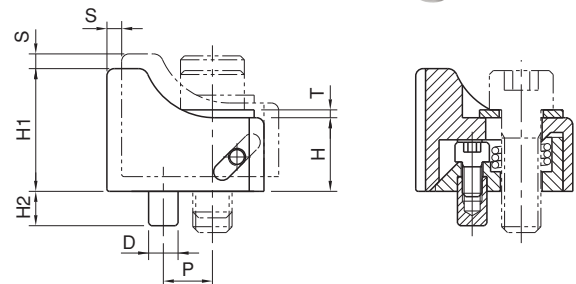

Montage und Verwendung / How To Use and Install

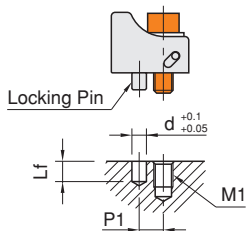

Nr.	M1	d	Lf	P1
CP107-08015	M 8	6	8	10
CP107-10019	M10	8	11	12
CP107-12023	M12	10	14	16
CP107-16025	M16	14	18	20

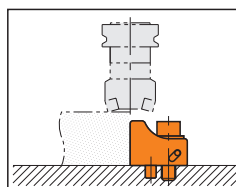

1 Stift und 1 Schraube erforderlich

Drill a cap-screw hole and a locking-pin hole as specified on the up.

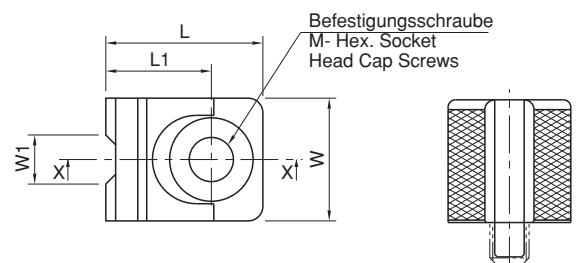

Referenz-Nr. Order No.	s	w	w1	h1	L1	P	d (h7)	h2	M	L	h	t	Spannkraft Clamping Force (N)	zulässiges Drehmoment Allowable Screw Torque (N·m)	 (g)
2144-08015	3	25	10	6	24.5	10	6	7	M8	35	15	1.6	7.000	25	100
2144-10019	4	30	11	8	29	12	6	7	M10	43	19	2	8.500	50	185
2144-12023	5	35	12	9	37	16	8	10	M12	54	23	2.3	20.000	90	320
2144-16025	6	40	14	10	45	20	10	10	M16	65	25	3.2	30.000	150	520

2144

- Gehärtet
- Schwarz beschichtet

2144

- Hardened
- Black coating

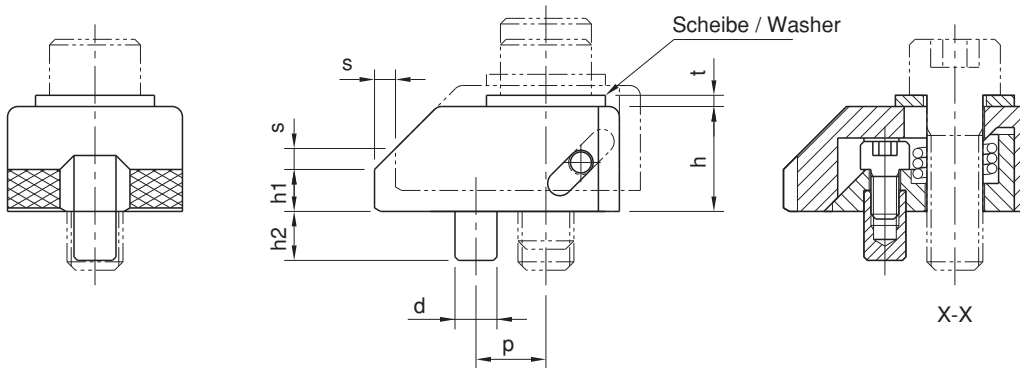
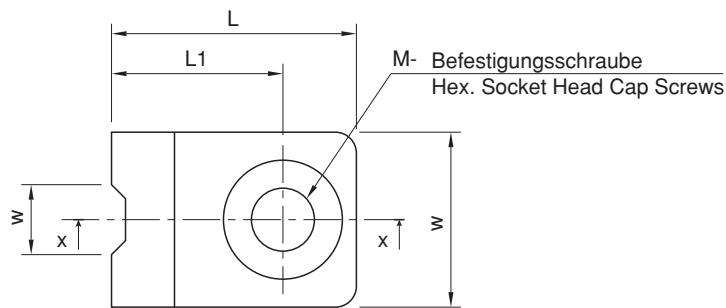

Anwendungsbeispiel / Application Examples

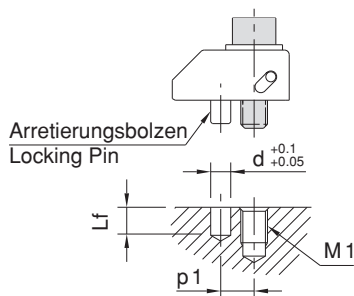

Referenz-Nr. Order No.	M1	d	Lf	p1
2144-08015	M 8	6	8	10
2144-10019	M10	6	8	12
2144-12023	M12	8	11	16
2144-16025	M16	10	11	20

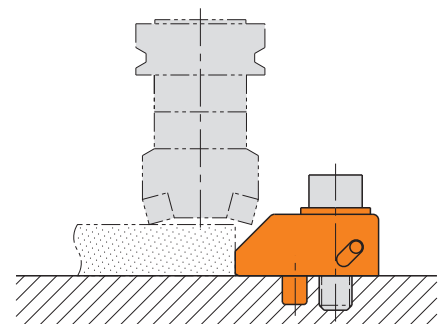

Referenz-Nr. Order No.		s1	m	sw	L	h	k	n	b	Spannkraft Clamping Force kgf	
											(g)
2150-08	8	1.4	5	4	23	9.5	6	7.7	13	310	25
2150-10	10	1.4	5	4	23	14	6	9.7	15	310	35
2150-12	12	1.2	7	5	28	15	7	11.7	18	340	60
2150-14	14	1.7	7	7	30	22	8	13.7	22	800	95
2150-16	16	1.7	10	8	30	22	9	15.7	25	1500	130
2150-18	18	2	10	8	35	28	10	17.7	28	1500	190
2150-20	20	2.5	13	10	40	32	12	19.7	32	2000	290
2150-22	22	2.5	13	12	45	38	14	21.7	35	2000	390

2150

- Die T-Nut des Produkts tritt vollständig in die Nut der Tischplatte ein. Da nur der exzentrische Kopfstück auf der Tischoberfläche verbleibt, ist ein einfaches Spannen der dünnen Teile möglich.
- geeignet für T-Nut DIN 650
- Gehärtet
- Schwarz beschichtet

2150

- T-Slot of the product enters in the slot of the bench completely. Since only the eccentric headpiece remains on the surface of the table, this provides easy clampings of the thin pieces.
- It is in compliance with DIN 650 T-Slot
- Hardened
- Black coating

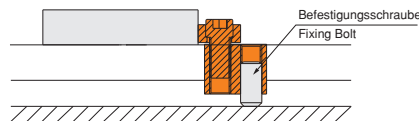
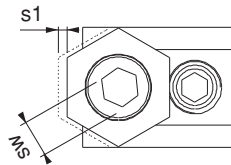
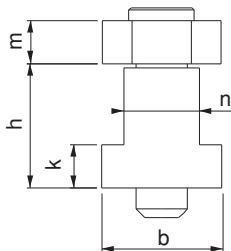

Flachspanner

Jaw Clamp

Referenz-Nr. Order No.		c	n		x	L	b	m1	sw	Spannkraft clamping force		
			min	max						f1 kgf	f2 kgf	
2170-12	12	2	2	6	4	46	21	10	5	500	60	120
2170-14	14	2.5	2.5	7.5	5	51	26	10	6	550	70	200
2170-16	16	3	2.5	8.5	6	61	27.5	12	6	800	90	290
2170-18	18	3	2	8	6	67	35	13	8	900	100	420
2170-20	20	4	2.5	11	8.5	78	38	13	10	1200	140	640
2170-22	22	4.5	2.5	12	9.5	87	39	16.5	10	1600	190	830

2170

- Spannt das Werkstück gegen die Anlagefläche und Richtung Platte
- Arbeiten in T-Nut verschafft Höhenvorteil
- DIN 650 T-Nut konform
- Gehärtet
- Schwarz beschichtet

2170

- This product clamps the workpiece in the direction of resting and plate
- It's working in T-Slot provides height advantage
- It is in compliance with DIN 650 T-Slot
- Hardened
- Black coating

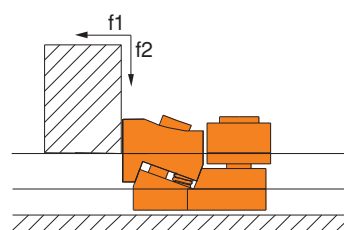
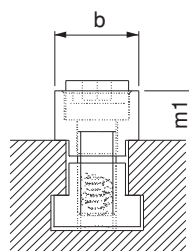
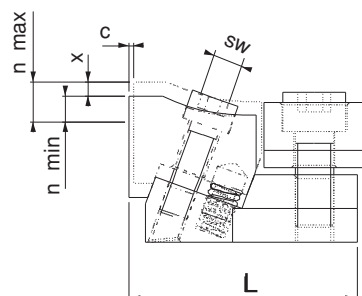

Referenz-Nr. Order No.	c			m	k	b	L	e DIN 912	Sikma Kuvveti Clamping Force kgf	
	min	max								
2190-5055	50	55	14-16-18-20-22	35	4	30	42	M12	1750	390



2190

- Spannen von einem Punkt in beide Richtungen und Plattenrichtung
- passend zu M12 Gewinde auf Platten und (a) 14-16-18-20-22
- Verwendung für T-Nuten
- Gehärtet
- Schwarz beschichtet

2190

- This product makes press process from one point to two directions and towards the direction of the plate.
- It is used in M12 thread plates and (a) 14-16-18-20-22
- T-Slot measurings
- Hardened
- Black coating

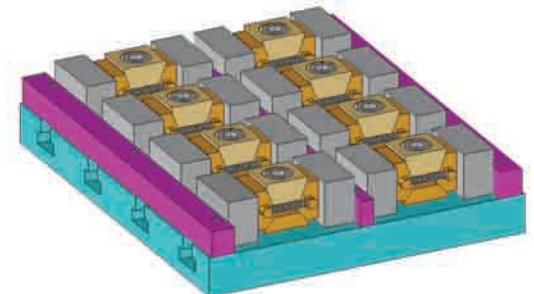
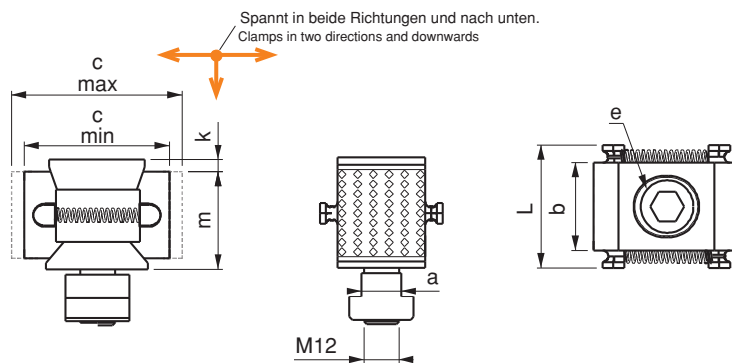

Referenz-Nr. Order No.	c			m	k	b	L	e DIN 912	Spannkraft clamping force kgf	
	min	max								
2210-4954	49	54	14-16-18-20-22	23	4	30	42	M12	1500	280



2210

- Spannen von einem Punkt in beide Richtungen und Plattenrichtung
- passend zu M12 Gewinde auf Platten und (a) 14-16-18-20-22
- Verwendung für T-Nuten
- Gehärtet
- Schwarz beschichtet

2210

- This product makes press process from one point to two directions.
- It is used in M12 thread plates and (a) 14-16-18-20-22
- T-Slot measurings
- Hardened
- Black coating

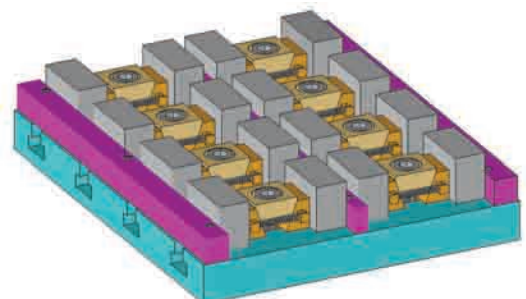
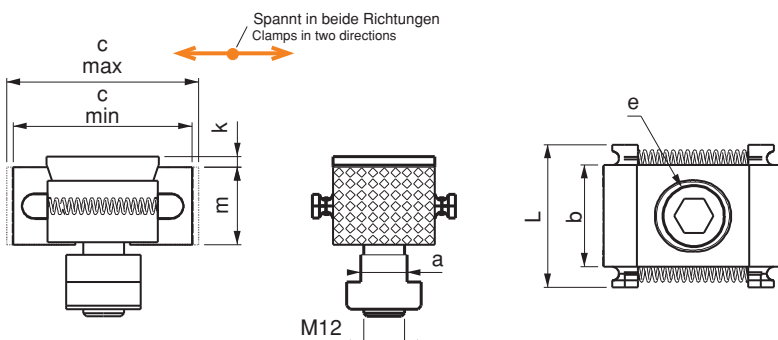

Referenz-Nr. Order No.	h x b x L	toleranz tolerance h	toleranz tolerance b	 (kg)	Stück Piece
2230-028	14x10x150	±0.01	±0.01	10.8	2
	16x10x150				2
	18x10x150				2
	20x10x150				2
	22x10x150				2
	24x10x150				2
	26x10x150				2
	28x10x150				2
	30x10x150				2
	32x10x150				2
	35x10x150				2
	40x10x150				2
	45x10x150				2
50x10x150	2				



- 2230**
- Als Unterlage beim Parallel- Spannen und Feinbearbeitung
 - 28 Stück.
 - Gehärtet
 - Set in Holzkiste

- 2230**
- This product is used for parallel coupling of the workpieces and as the base for sensitive machinings of the work pieces.
 - 28 pieces.
 - Hardened
 - Set is in the wooden box

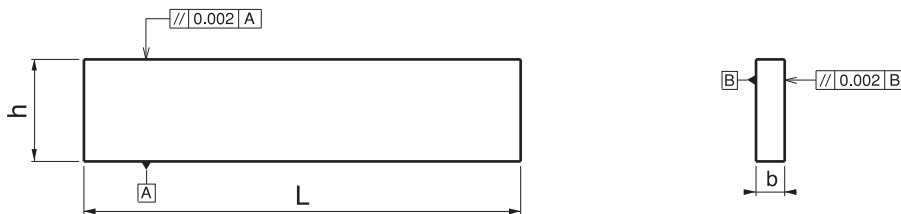



Referenz-Nr. Order No.	h x b x L	toleranz tolerance h	toleranz tolerance b	 (kg)	Stück Piece
2250-016	20x6x100	±0.01	±0.01	10.6	2
	23x8x100				2
	28x10x100				2
	36x12x150				2
	42x14x150				2
	48x16x150				2
	58x18x150				2
	65x22x150				2

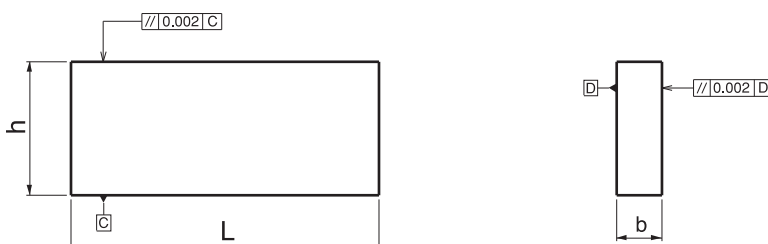

- 2250**
- Als Unterlage beim Parallel- Spannen und Feinbearbeitung
 - 16 Stück.
 - Gehärtet
 - Set in Holzkiste

- 2250**
- This product is used for parallel coupling of the workpieces and as the base for sensitive machinings of the work pieces.
 - 16 pieces.
 - Hardened
 - Set is in the wooden box



Referenz-Nr. Order No.	a	b	c	Øv		 (g)
				min	max	
2270-140	140	82	40	20	110	1980
2270-204	204	115	66	15	150	6150

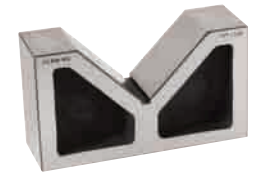

2270

- Material: Guss
- Verwendung als Unterlage bei Spannen zylindrischer Werkstücke und Feinbearbeitung
- 2-er Set

2270

- Material: Casting
- This product is used in parallel couplings of cylindrical pieces and it is also used as the base for sensitive machinings of the workpieces.
- Set of two pieces

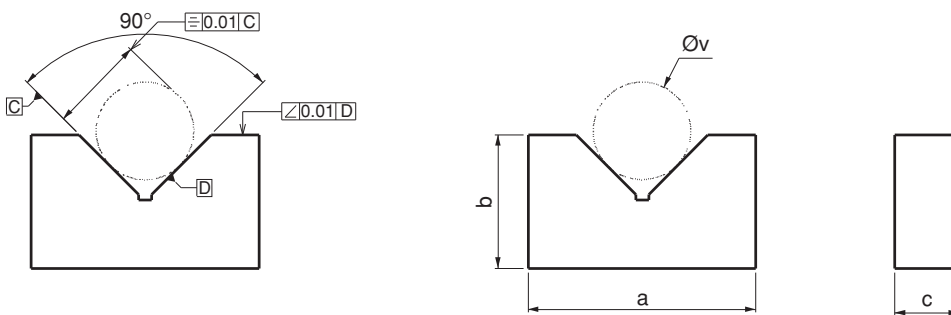

“X V” Spannblock

XV-Clamping Block

Referenz-Nr. Order No.	a	b	c	Øv1		Øv2		Øv3		Øv4		 (g)
				min	max	min	max	min	max	min	max	
2290-120	120	100	60	12	40	12	60	12	75	12	90	2840
2290-150	152	132	74	15	80	15	95	15	110	15	120	4975



2290

- Material: Guss
- Verwendung als Unterlage beim Spannen der Zylinderwerkstücke und Feinbearbeitung. Aufgrund X-Form kann man alle 4 Flächen verwenden.

- 2-er Set

2290

- Material: Casting
- This product is used in parallel couplings of cylindrical pieces and it is also used as the base for sensitive machinings of the workpieces. It provides using advantage in 4 different surfaces because of being in X form.

- Set of two pieces

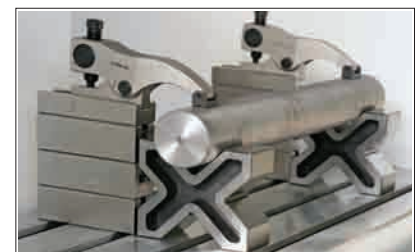
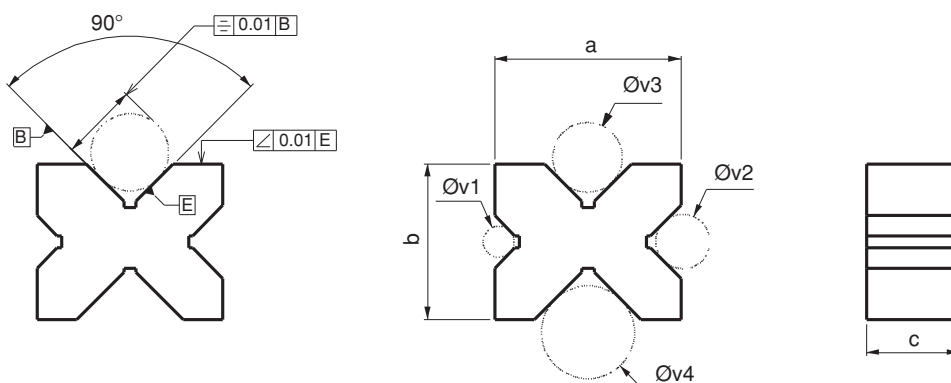

Referenz-Nr. Order No.	L	h	a	a1	b	b1	sw	 (g)
2295-090	90	39	55	73	7	21-35	8	1480
2295-115	115	49	65	82.5	8.5	31-42	10	2690
2295-130	130	56	75	98	10	37-48	12	4160





2295

- Durch Einfräsung eines, Vogelnestes kann das Werkstück gespannt werden.
- Gehärtet
- Schwarz beschichtet

2295

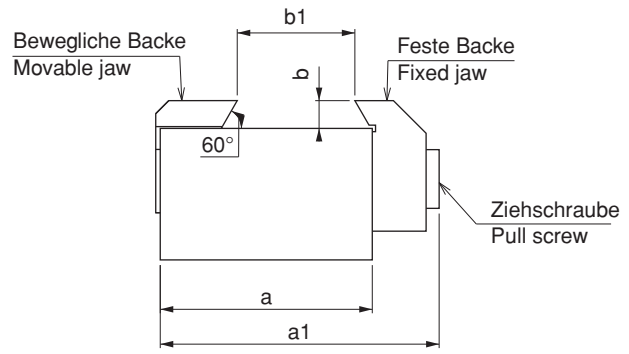
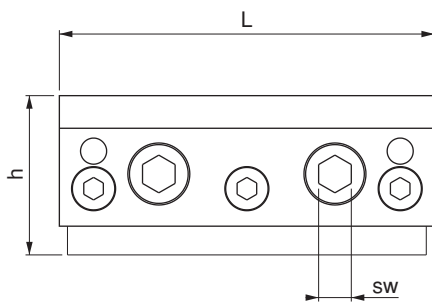
- Apparatus is connected at workpiece, swallow nest opening.
- Hardened
- Black coating



Referenz-Nr. Order No.	a	h	L	d	 (g)
2297-090	55	58	87	M10	2110
2297-115	65	68	110	M12	3750
2297-130	75	80	126.5	M12	5830



2297

- Gehärtet
- Schwarz beschichtet

2297

- Hardened
- Black coating

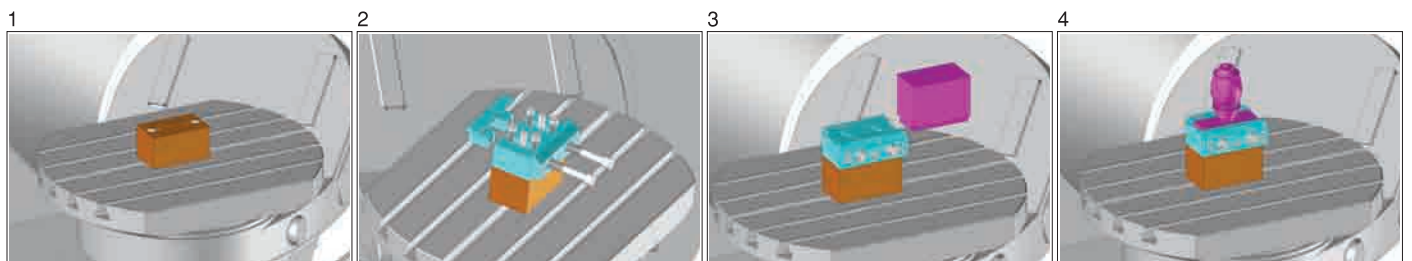
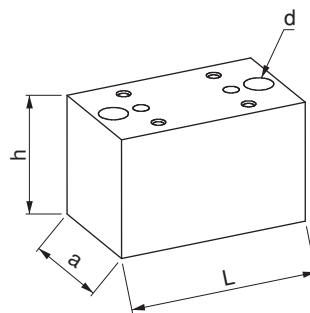

Schraubstöcke

Vices

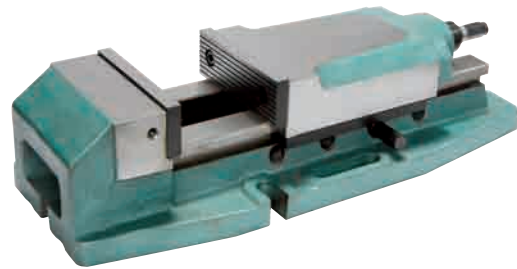

Referenz-Nr. Order No.	a	a1	b	c	e	f	h	L	i	s	n	Spannkraft clamping force kgf	 (kg)
2300-127130	170	127	0-130	63	112	209	112	374	115	100	49	2750	31



2300

- Wichtigste Eigenschaft: Der Grip-Schraubstock passt sich dem Werkstück an.
Bei Bedarf wird die Form festgesetzt (siehe bilder untetn 1-2-3-4)
- Backe: Gehärtet

2300

- Clamping jaws need to be connected to this form and take the form according to the workpiece to be set permanently, the most important feature of the vice grip. (1-2-3-4 shape as shown in)
- Jaw : Hardened

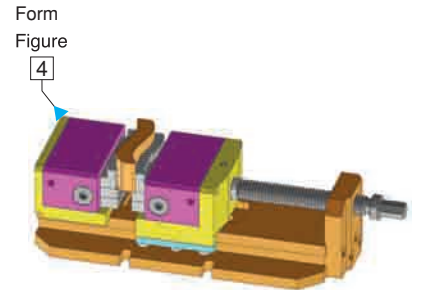
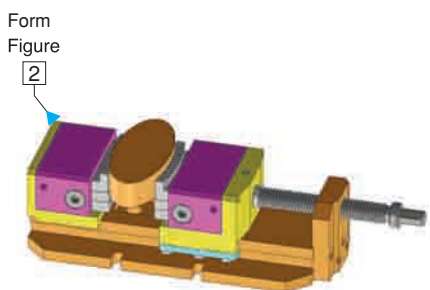
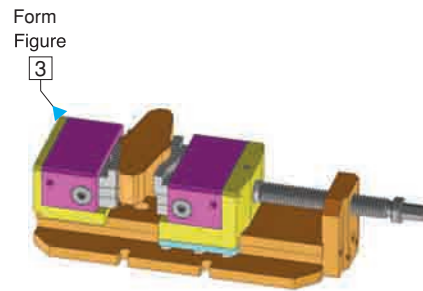
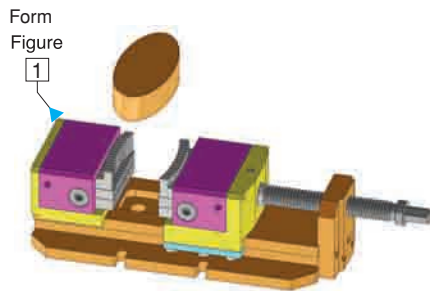
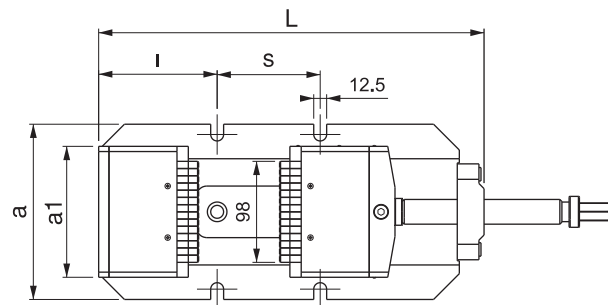
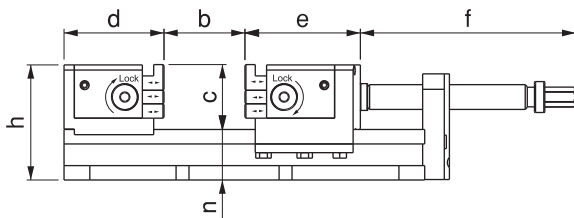

Referenz-Nr. Order No.	A min-max	Strok	hydraulisch hydraulic Bar	Spannkraft Clamping Force kgf	(kg)
2305-0251	0 - 251	13 x 2	30	750	15.2
			40	1000	
			50	1250	
			60	1500	



2305

- Beim Werkstückspannen wird gleichzeitig zentriert. Der Vorteil dieses Systems ist, dass besonders bei unterschiedlichen Außendurchmessern ohne zusätzliches Zentrieren bearbeitet werden kann.
- Weiterer Vorteil: Weichbacken können dem Werkstück angepasst werden (siehe Bild 1-2-3-4)
- Sämtliche bewegliche Flächen sind feingeschliffen.
- System hydraulisch betrieben
- Ölzufluss - Ölausfluss
- Schwarz beschichtet

2305

- This product fixes the material to be processes and at the same time it makes centering. The advantage of this system specially shows itself when making machinings of the materials having different outer diameter measurements as it implements this process without changing the center. It's other characteristic is to apply the form of the piece to be machined with soft claws (as seen in Figures: 1-2-3-4-5 and 6).
- Entire moving surface is sensitively grinded and hardened.
- Hydraulic system works
- Oil inlet - Oil outlet
- Black coating

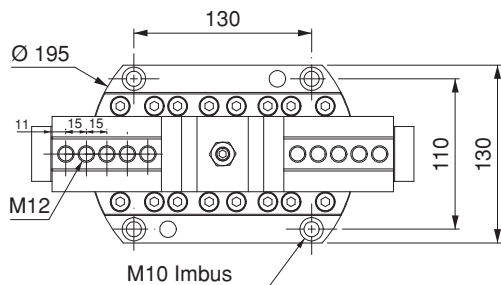
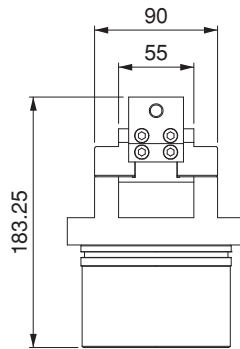
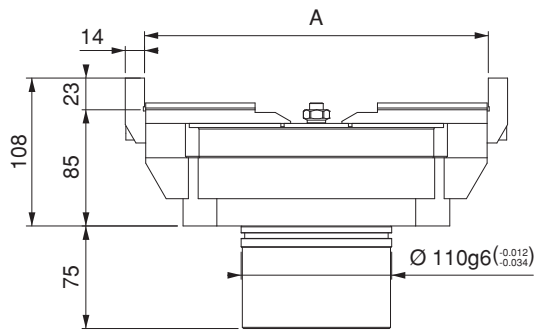

Form Figure 1

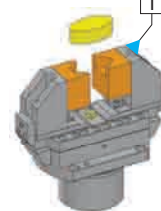

Form Figure 2

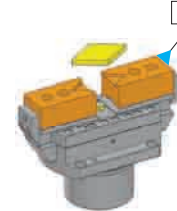

Form Figure 3

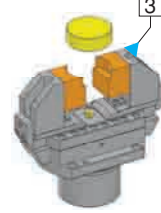

Form Figure 4

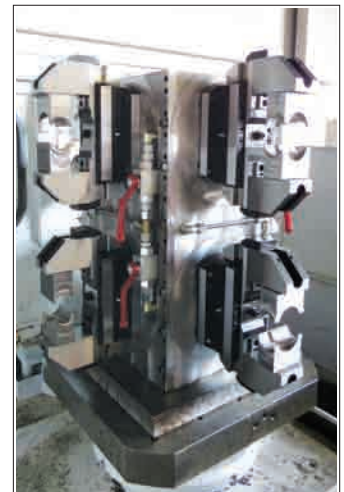
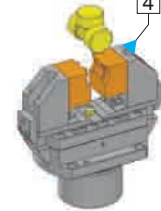

Pneumatischer Zentrierschraubstock

Pneumatic Centering Vice

Referenz-Nr. Order No.	A min-max	Strok	pneumatisch pneumatic Bar	Spannkraft Clamping Force kgf	(kg)
2307-0188	0-188	8.5x2	6	750	18.5

2307

- Pneumatikbetrieb

2307

- Pneumatic system works

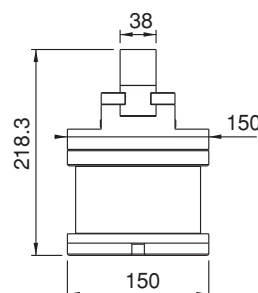
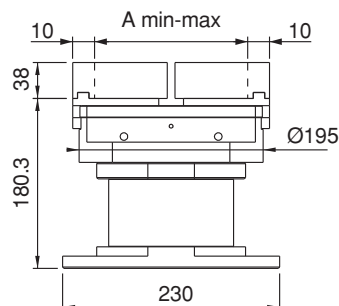
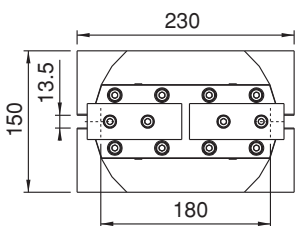

Mechanischer Schraubstock Anwendungsbeispiel

Mechanical Steel Vice Application



Ref.-Nr. Order No.	a	L	c/2	öffnen opens 2 x mm	Werkstückspannkapazität work piece coupling capacity (mm)	b	b1	b2 ±0,02	b3	p1	p2	s1	s2	Spannkraft Clamping Force kgf	Drehmoment Allowable Screw Torque (N-m)	SW	(kg)
2310-060	60	120	90	20	120	23.5	70.5	67.5	91	174	124	150	100	800	45	9	7
2310-078	78	180	130	30	180	33	97	93	126	224	124	200	100	1500	110	12	14
2310-100	100	220	154	38	220	35	99	95	130	274	174	250	150	1500	110	12	22
2310-125	125	260	174	47	260	38	108	103	141	324	174	300	150	2000	190	14	35
2310-157	157	350	208	75	350	46	123	118	164	424	224	400	200	2200	210	17	65

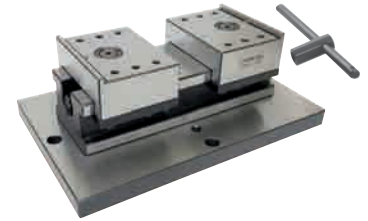

2310

- Zentrieren automatisch beim Spannen
- Vorteil: verwendbar auch bei unterschiedlichen Abmessungen (siehe Abb. 1-2-3-4-5-6)
- Verwendung: Fräsen CNC und mechanisch, Schleifen und sonstige Industriemaschinen
- Backen müssen separat bestellt werden.
- Schwarz beschichtet

2310

- This product fixes the material to be processes and at the same time it makes centering. The advantage of this system specially shows itself when making machinings of the materials having different outer diameter measurements as it implements this process without changing the center. It's other characteristic is to apply the form of the piece to be machined with soft claws (as seen in Figures: 1-2-3-4-5 and 6).
- Area of Using: This product is used in various industry machines such as CNC and mechanical milling machines, grinding and auger.
- Entire moving surface is sensitively grinded and hardened.
- You need to purchase jaws separate.
- Black coating

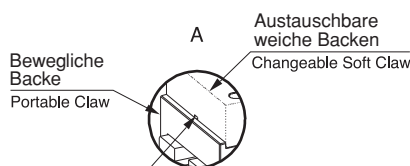
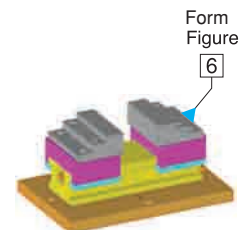
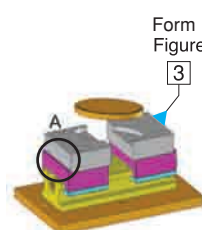
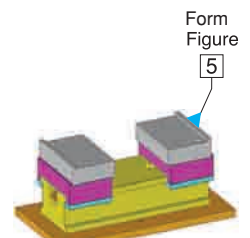
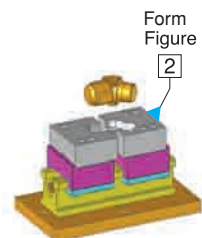
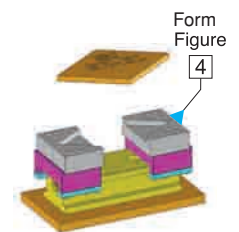
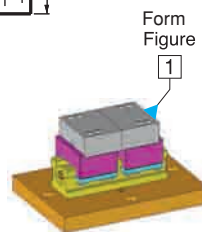
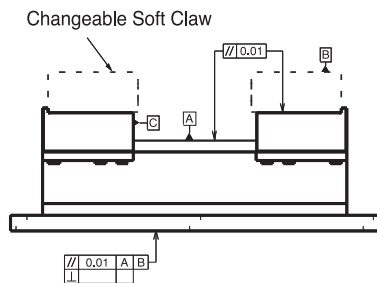
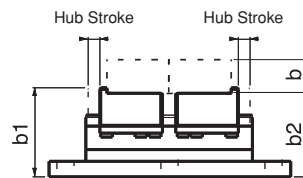
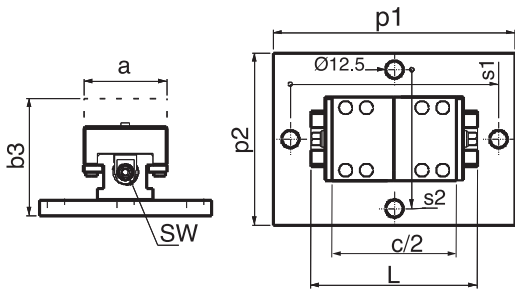
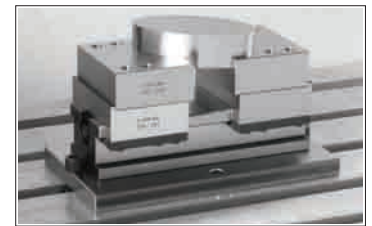

Wiederholgenauigkeit Demontage und Montage von weichen Backen ist ±0.02.
Demounting and mounting of portable jaw wedge soft claws is ±0.02.

Ref.-Nr. Order No.	a	L	c/2	öffnen opens 2 x mm	b1	b2 ±0,02	p1	p2	s1	Spannkraft Clamping Force kgf	Drehmoment Allowable Screw Torque (N-m)	sw	 (kg)
2315-060	60	120	90	20	117.5	114.5	174	56	150	800	45	9	4.1
2315-078	78	180	130	30	159	155	224	73.5	200	1500	110	12	10
2315-100	100	220	154	38	159	155	274	95	250	1500	110	12	17.2



2315

- Dieses Produkt fixiert das zu bearbeitende Werkstück und führt gleichzeitig eine Zentrierung durch.
Der Vorteil dieses Systems zeigt sich besonders bei der Bearbeitung von Materialien mit unterschiedlichen Außendurchmessern, da es diesen Prozess ohne Wechsel des Zentrums durchführt.
- Anwendungsbereiche: CNC Maschinen und 5-Achs Bearbeitungszentren
- Die gesamte Lauffläche ist fein geschliffen und gehärtet.
- Backen müssen separat bestellt werden.
- Schwarz beschichtet

2315

- This product fixes the material to be processes and at the same time it makes centering. The advantage of this system specially shows itself when making machinings of the materials having different outer diameter measurements as it implements this process without changing the center.
- Area of Using: This product is used in various industry machines such as CNC and CNC 5-Axis mechanical milling machines,
- Entire moving surface is sensitevely grinded and hardened.
- You need to purchase jaws separate.
- Black coating

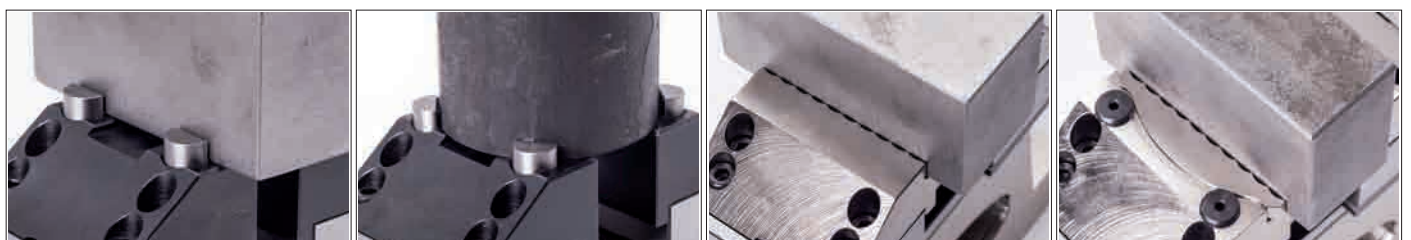
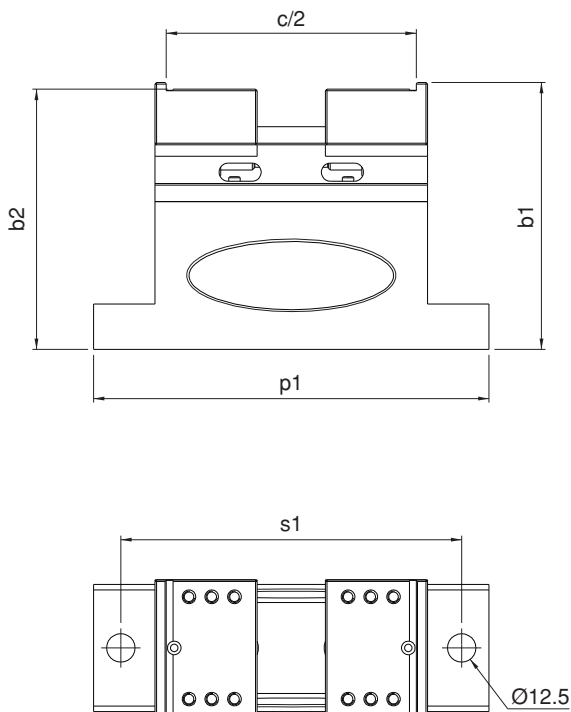

Referenz-Nr. Order No.	f min-max	h	h1	L1	a
2310-23150601	10-50	16.5	23.5	45	60
2310-23150781	10-70	26	33	65	78
2310-23151001	10-86	28	35	77	100
2310-23151251	10-104	31	38	87	125
2310-23151571	10-160	39	46	104	157

- Gehärtet
- Nickelbeschichtung
- Hardened
- Nickel Coating

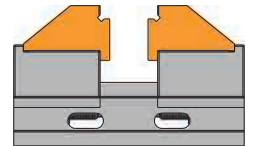
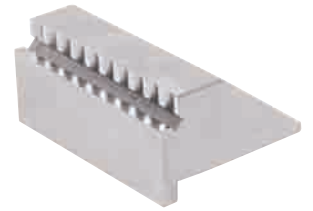
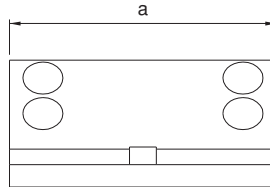
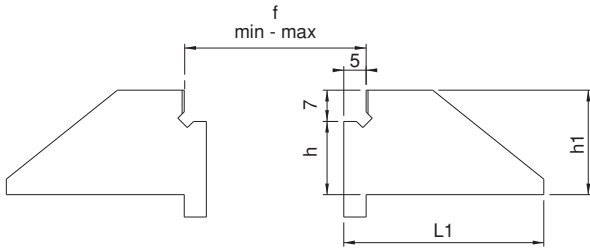

Passend für Produktnr.
2310 und 2315

Referenz-Nr. Order No.	f min-max	h	h1	L1	a
2310-23150602	8-48	20.5	23.5	45	60
2310-23150782	8-68	29	33	65	78
2310-23151002	8-84	31	35	77	100
2310-23151252	8-102	34	38	87	125
2310-23151572	8-158	46	46	104	157

- Gehärtet
- Nickelbeschichtung
- Hardened
- Nickel Coating

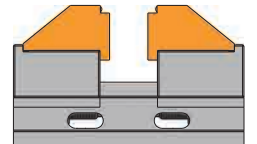
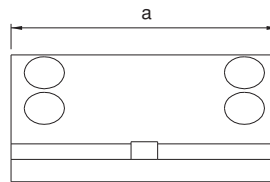
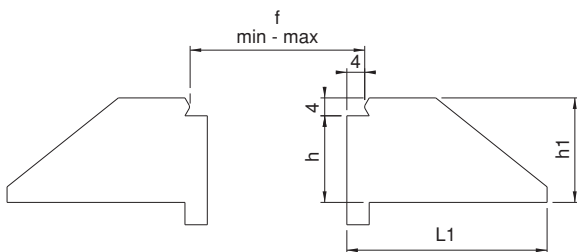

Passend für Produktnr.
2310 und 2315

Referenz-Nr. Order No.	f min-max	h	h1	L1	a
2310-23150603	10-50	16.5	23.5	47	60
2310-23150783	10-70	26	33	67	78
2310-23151003	10-86	28	35	79	100

- Gehärtet
- Nickelbeschichtung
- Hardened
- Nickel Coating

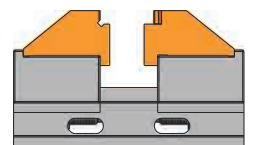
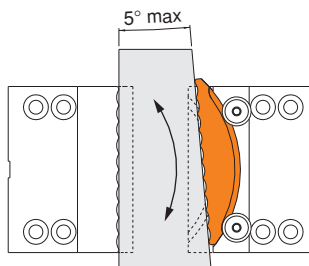
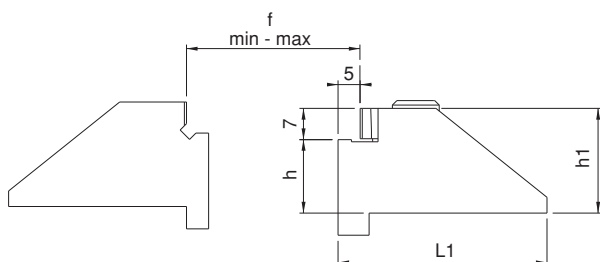

Passend für Produktnr.
2310 und 2315

Referenz-Nr. Order No.	f		h	h1	L1	a
	min	max				
2310-23150604	46-72	23-63	23.5	27.5	45	60
2310-23150784	59-95	23-83	33	37	65	78
2310-23151004	77-124	23-99	35	39	77	100

- Vor dem Kauf bitte die Backeneigenschaft angeben. (Verzahnt oder Glatt)
- Gehärtet
- Schwarz beschichtet
- You should specify the jaw feature before make purchase. (Serrated or Straight)
- Hardened
- Black Coating

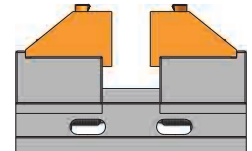
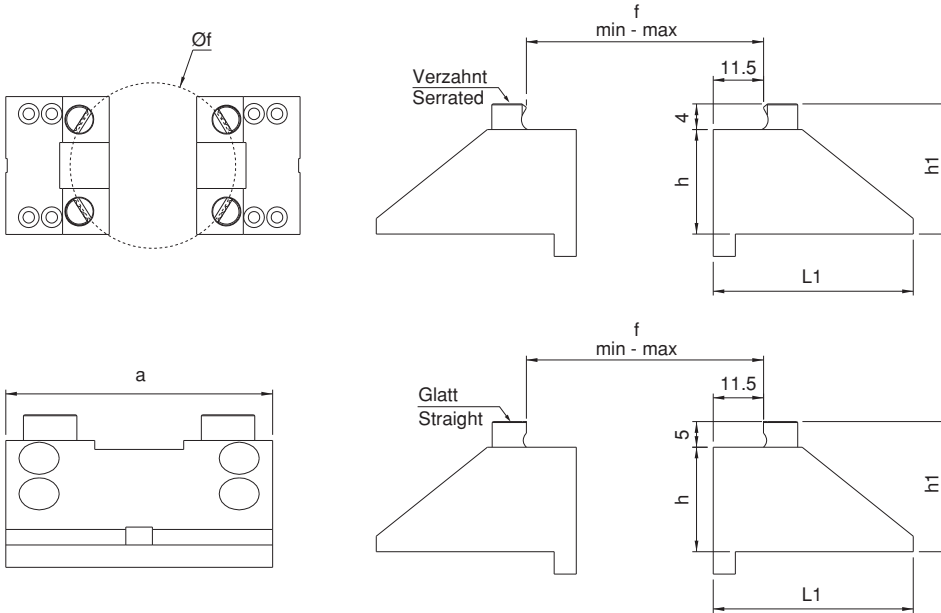

Passend für Produktnr. 2310 und 2315

Referenz-Nr. Order No.	f min-max	f1 min-max	h	h1	g	L1	a
2310-23150785	10-70	20-80	10	33	16	65	78
2310-23151005	10-86	20-96	10	35	18	77	100
2310-23151255	10-104	20-114	10	38	21	87	125
2310-23151575	10-160	20-170	10	46	29	104	157

- Gehärtet
- Schwarz beschichtet
- Hardened
- Nickel Coating

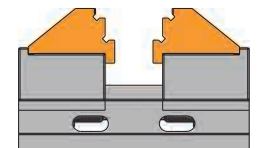
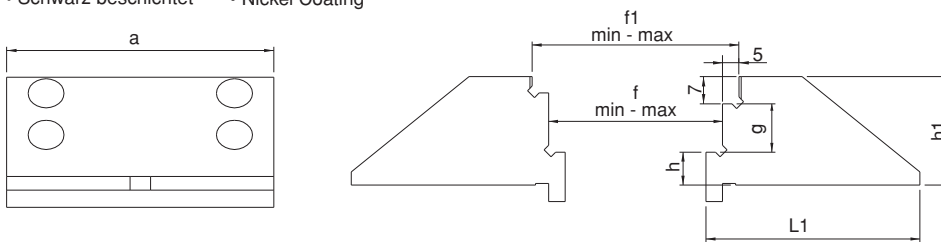
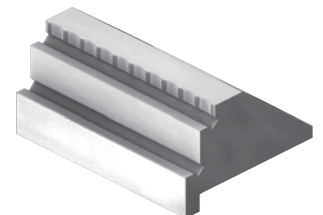

Passend für Produktnr. 2310 und 2315

Referenz-Nr. Order No.	a	b	c
2310-23150606	60	23.5	45
2310-23150786	78	33	65
2310-23151006	100	35	77
2310-23151256	125	38	87
2310-23151576	157	46	104

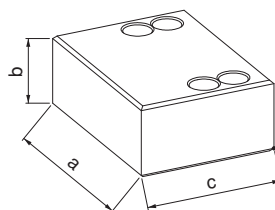

Weiche Backe
Soft Jaw

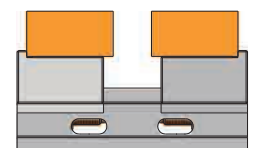

Passend für Produktnr. 2310 und 2315

Referenz-Nr. Order No.
2310-2315-060AG
2310-2315078AG
2310-2315100AG
2310-2315125AG
2310-2315157AG

Grundkörper
Sub-body

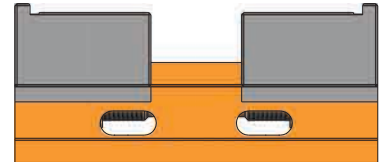

Referenz-Nr. Order No.
2310-2315060GÇ
2310-2315078GÇ
2310-2315100GÇ
2310-2315125GÇ
2310-2315157GÇ

Bewegliche Backe
Portable Jaw

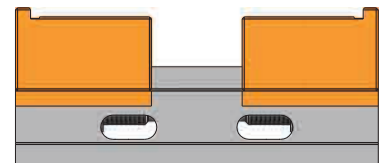

Referenz-Nr. Order No.
2310-2315060M
2310-2315078M
2310-2315100M
2310-2315125M
2310-2315157M

Spindel
Pin

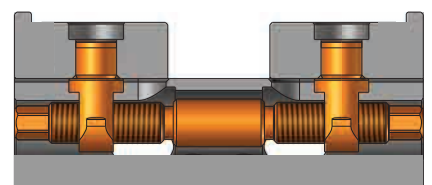

Referenz-Nr. Order No.	b	Spannkraft Clamping Force kgf	 (kg)
2320-160200	0-200	4500	60

2320

- Verwendung: Fräsen CNC und mechanisch, Schleifen und sonstige Industriemaschinen
- Aktivflächen komplett feingeschliffe und feingehärtet

2320

- Area of Using: CNC and mechanical milling machines, drilling machines, various industrial machines
- Entire moving surface is sensitively grinded and hardened.

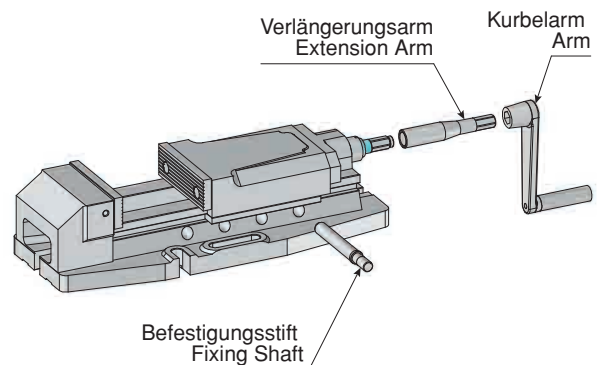
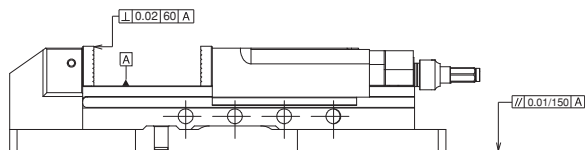
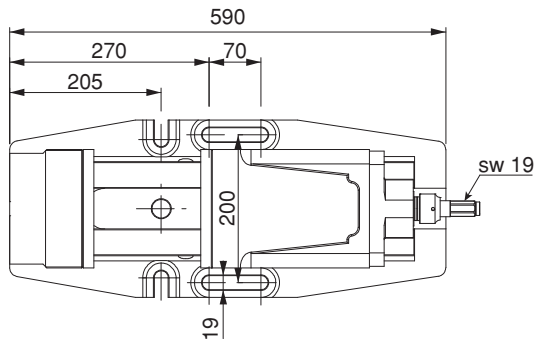
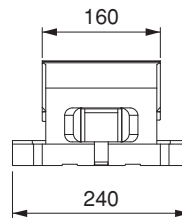
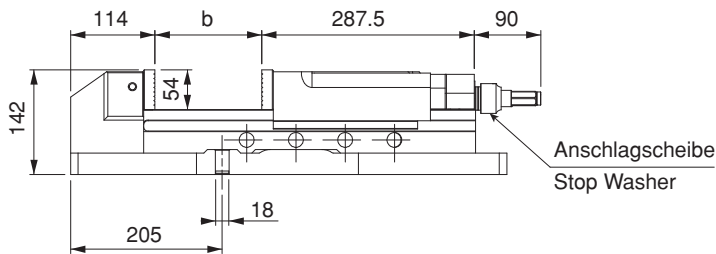
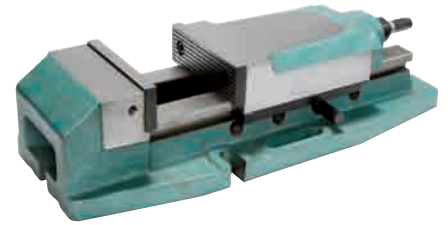

Referenz-Nr. Order No.	a	b	c	L	d	e	f	h	i	n	s	Spannkraft clamping force kgf	Drehmoment Allowable Screw Torque (N-m)	 (kg)
2330-127160	127	0-160	60	422	99	78	160	115	125	55	200	4500	170	28
2330-157200	157	0-200	60	462	99	78	160	115	150	55	200	4500	170	46
2330-157300	157	0-300	60	562	99	78	160	115	150	55	250	4500	170	51
2330-197300	197	0-300	60	562	99	78	160	115	150	55	250	4500	170	66
2330-197400	197	0-400	60	662	99	78	160	115	150	55	350	4500	170	73
2330-197500	197	0-500	60	762	99	78	160	115	150	55	250/250	4500	170	80



2330

- gehärtet und feingeschliffen Aufgrund Federsystem wird das Werkstück nach unten gespannt
Aktivflächen komplett fein geschliffen
- Verwendung: Fräsen CNC und mechanisch, Schleifen und sonstige Industriemaschinen
- Aktivflächen komplett feingeschliffen und feingehärtet

2330

- Mechanical Steel Vice is hardened and it has excellent way of using because of being sensitively grinded. It's usage characteristic fixes the material to be machined and at the same time it pulls the material to the base of the vice because of having springed system of modular jaws taking place in the moving jaws. Entire moving surface is sensitively grinded. With it's wedged fixing characteristic, moving jaw distance can be adjusted rapidly and can be used with convenience.
- Area of Using: CNC and mechanical milling machines, grinding and drilling machines, various industrial machines
- Entire moving surface is sensitively grinded and hardened.

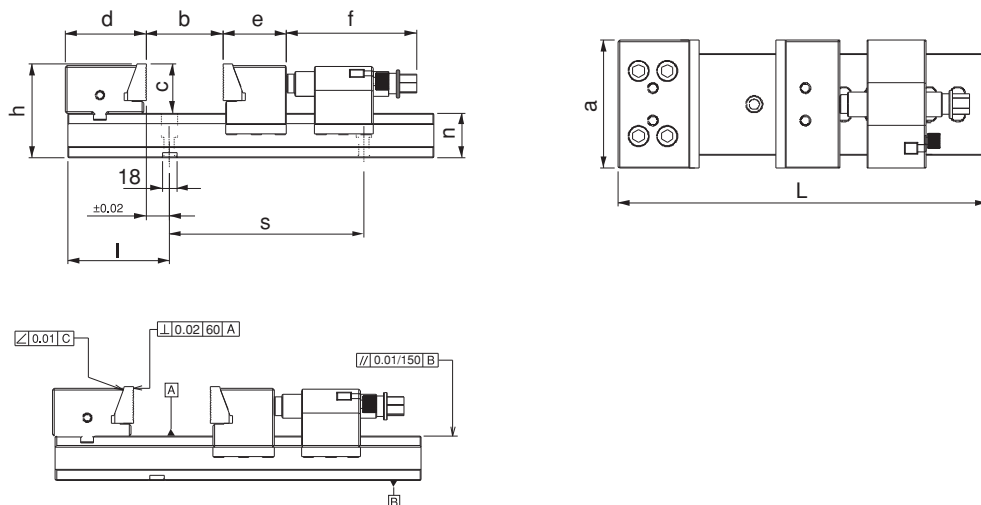



Mittlerer Teil zum Spannen von zwei Werkstücken

Medium Part to Connect Two Work Piece

Referenz-Nr. Order No.	b1	 (kg)
2330-127	50	3.1
2330-157	50	3.8
2330-197	50	4.7

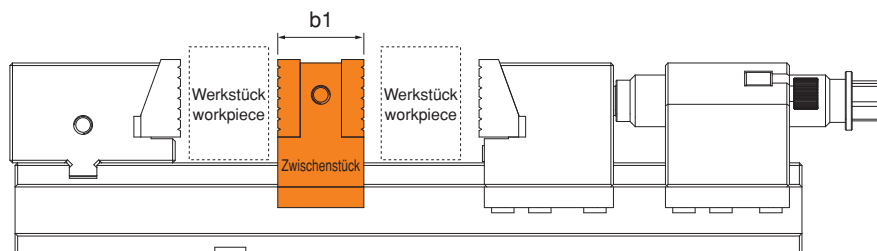
Hinweis: Um mehrere Werkstücke spannen zu können, werden Zwischenstücke benötigt.
Notes: To be able to clamp several workpieces, intermediate pieces are required.



Referenz-Nr. Order No.	a	L	L1	b1	b	c	h	i	n	Ød	Spannkraft clamping force kgf	Drehmoment Allowable Screw Torque (N-m)	 (kg)
2345-127	127	202	260	53	0-58	60	115	163.5	55	12.5	4500	170	28



2345

- bestehend aus 2 beweglichen Teilen
- Werkstück wird nach unten gespannt
- Aktivflächen komplett feingeschliffen und feingehärtet

2345

- Because of sliding clamping jaws it clamps the workpieces in opposite direction and down. The vice consists of two parts and it is parallel which provides clamping big tools, threading and similar processes easy.
- Entire moving surface is sensitively grinded and hardened.

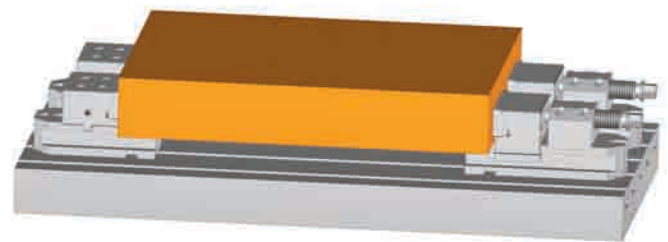
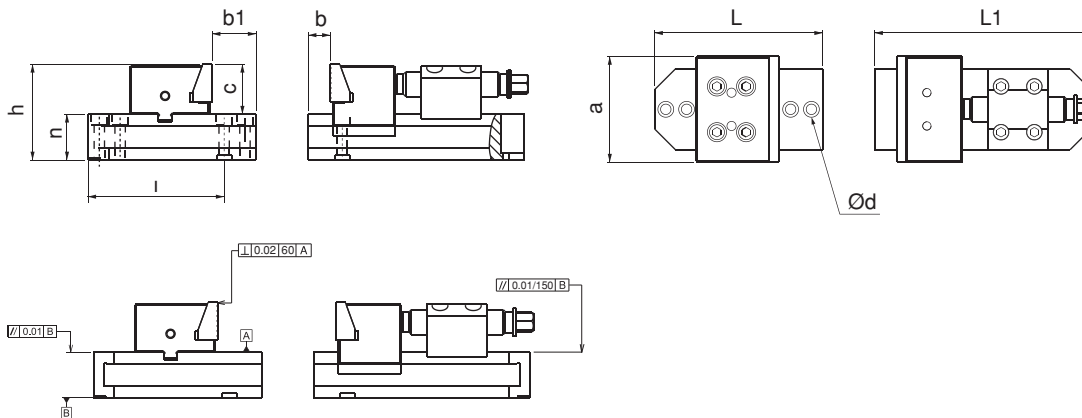

Referenz-Nr. Order No.	a	b	c	d	e	f	
2333-127	127	45	7	-	5	-	760
2333-157	157	45	7	-	5	-	935
2333-197	197	45	7	-	5	-	1180

2333
• Gehärtet

2333
• Hardened

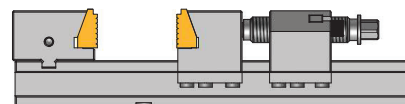
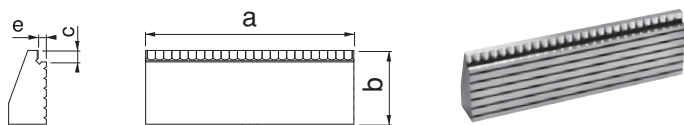

Referenz-Nr. Order No.	a	b	c	d	e	f	
2334-127	127	45	-	-	-	-	765
2334-157	157	45	-	-	-	-	960
2334-197	197	45	-	-	-	-	1185

2334
• Gehärtet

2334
• Hardened

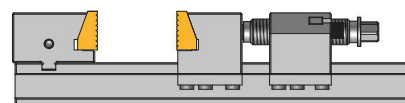
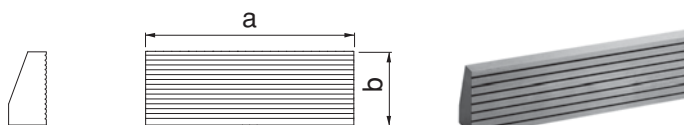

Referenz-Nr. Order No.	a	b	c	d	e	f	
2335-127	127	45	7	-	5	-	760
2335-157	157	45	7	-	5	-	935
2335-197	197	45	7	-	5	-	1180

2335
• Gehärtet

2335
• Hardened

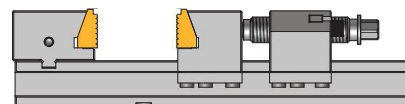
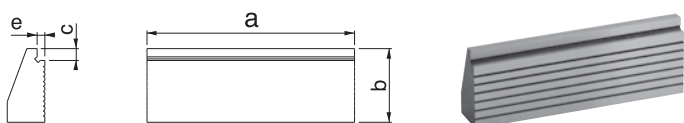

Referenz-Nr. Order No.	a	b	c	d	e	f	
2340-127	127	45	7	34	5	5	950
2340-157	157	45	7	34	5	5	1010
2340-197	197	45	7	34	5	5	1290

2340
• Gehärtet

2340
• Hardened

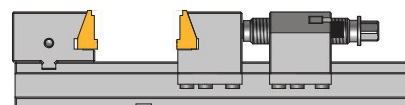
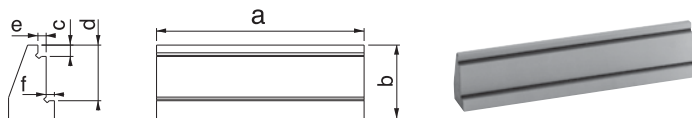

Referenz-Nr. Order No.	a	b	c	d	e	f	
2336-127	127	45	7	34	5	5	950
2336-157	157	45	7	34	5	5	1010
2336-197	197	45	7	34	5	5	1290

2336
• Gehärtet

2336
• Hardened

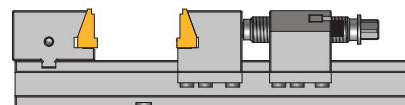
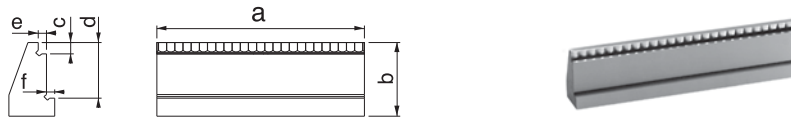

Referenz-Nr. Order No.
2330-127160AG
2330-157200AG
2330-157300AG
2330-197300AG
2330-197400AG
2330-197500AG

**2330
Grundkörper
Sub-body**

Hinweis: Um mehrere Werkstücke spannen zu können,
werden Zwischenstücke benötigt.
Notes: To be able to clamp several workpieces,
intermediate pieces are required.

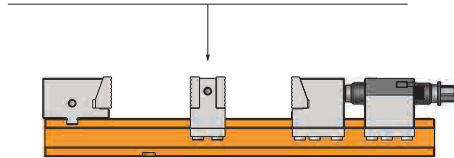

Referenz-Nr. Order No.
2330-127SÇ
2330-157SÇ
2330-197SÇ

**2330
Fixe Backe
Fixed Jaw**

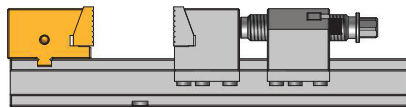

Referenz-Nr. Order No.
2330-127GÇ
2330-157GÇ
2330-197GÇ

**2330
Bewegliche Backe
Portable Jaw**

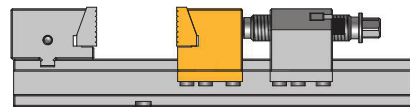

Referenz-Nr. Order No.
2330-127GS
2330-157GS
2330-197GS

**2330
Bewegliche Mutter
Portable nut**

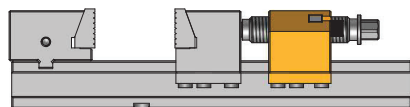

Referenz-Nr. Order No.
2330-127SK
2330-157SK
2330-197SK

**2330
Anschlag
Wedge of Stop**

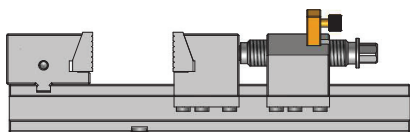

Referenz-Nr. Order No.
2330-127157197M

**2330
Spindel
Pin**

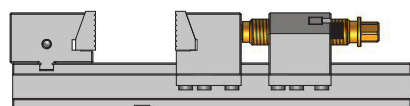

Referenz-Nr.
Order No.
2345-127SAG

2345
Grundkörper
Fixed Sub-body

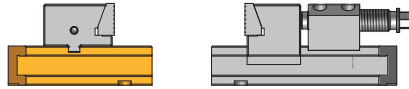

Referenz-Nr.
Order No.
2345-127GAG

2345
Beweglicher Grundkörper
Portable Sub-body



Referenz-Nr.
Order No.
2345-127SÇ

2345
Fixe Backe
Fixed Jaw



Referenz-Nr.
Order No.
2345-127GÇ

2345
Bewegliche Backe
Portable Jaw



Referenz-Nr.
Order No.
2345-127SS

2345
Bewegliche Mutter
Fixed Nut

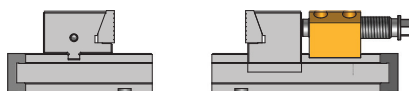

Referenz-Nr.
Order No.
2330-127157197M

2330
Spindel
Pin



Referenz-Nr. Order No.	a	b	c	k	L	d	e	h	i	n ±0.01	Spannkraft clamping force kgf	Bewegungsstärz Moving Distance Torque	(kg)
2350-160E	160	160	58	310	530	130	145	160	190	105	2000	4	62

2350

- 6 bar
- Spannkraft 2000 kg, verstellbar
- Verwendung: Fräsen CNC und mechanisch undsonstige Industriemaschinen
- Aktivflächen komplett feingeschliffen und feingehärtet

2350

- It works with 6 Bar Air. It provides speed in clamping-opening processes because of it's pneumatic structure.
- It fixes the workpiece with it's 2000 kgf clamping force. Clamping force can be adjusted with it arbitrary bar adjustment button.
- Area of Using: CNC and mechanical milling machines, drilling machines, various industrial machines
- Entire moving surface is sensitively grinded and hardened.

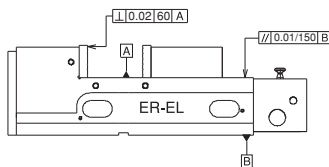
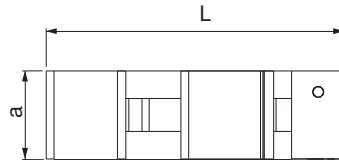
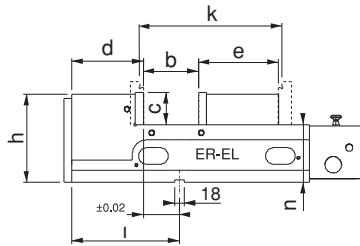

• Ersatzbacken sind nicht enthalten

• "k" measurement is reached by the spare jaws. The spare jaws are not included in the set.

Referenz-Nr. Order No.	a	a1	b	c	k	L	d	e	h	i	n ±0.01	Spannkraft clamping force kgf	Bewegungsstärz Moving Distance Torque	(kg)
2370-051	130	188	60	58	135	327	64	209	160	-	105	1100	4	37
2370-052	130	185	140	63	225	400	69	300	160	173	105	2200	4	44
2370-053	160	201	200	63	300	485	93	353	166	170	105	3300	4	63
2370-054	200	240	250	63	360	530	93	410	166	185	105	4100	4	81

2370

- 6 bar
- Spannkraft 1100 - 4100 kg, einstellbar
- Verwendung: Fräsen CNC und mechanisch und sonstige Industriemaschinen
- Aktivflächen komplett feingeschliffen und feingehärtet

2370

- It works with 6 Bar Air. It provides speed in clamping-opening processes because of it's pneumatic structure.
- It fixes the workpiece with it's 1100 kgf and 4100 kgf clamping force. Clamping force can be adjusted with it arbitrary bar adjustment button.
- Area of Using: CNC and mechanical milling machines, drilling machines, various industrial machines
- Entire moving surface is sensitively grinded and hardened.

Pneumatischer Schraubstock

Pneumatic Vice

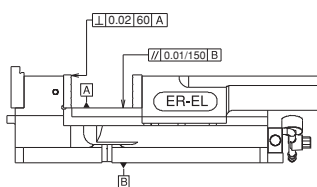
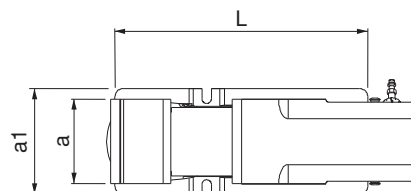
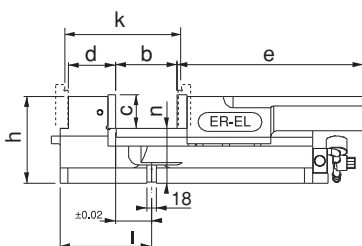

• Ersatzbacken sind nicht enthalten

• "k" measurement is reached by the spare jaws. The spare jaws are not included in the set.

2370-051 Detail

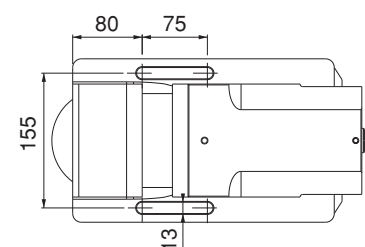

Referenz-Nr. Order No.	b	b1	b2	L	h	s	sw	Spannmenge coupling piece	Spannkraft Clamping force kgf	 (kg)
2375-092	92	61	224	430	119	400	19	2	2000	44
2375-192	192	61	324	530	119	500	19	2	2000	48.7
2375-342	342	61	474	680	124	650	19	2	2000	52.5
2375-442	442	61	575	780	124	750	19	2	2000	57



2375

- feingeschliffen, mehrfach verwendbar
- Spannen von 1 oder mehreren Werkstücken mit einer Bewegung
- Aktivflächen komplett feingeschliffen und feingehärtet

2375

- It is fine ground. As figures below it is multifunctional.
- It is designed for clamping 1 or more than one workpieces with only 1 tool motion.
- Entire moving surface is sensitively grinded and hardened.

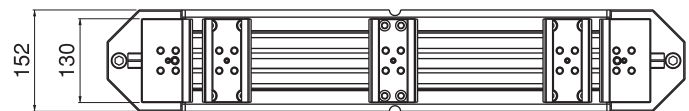
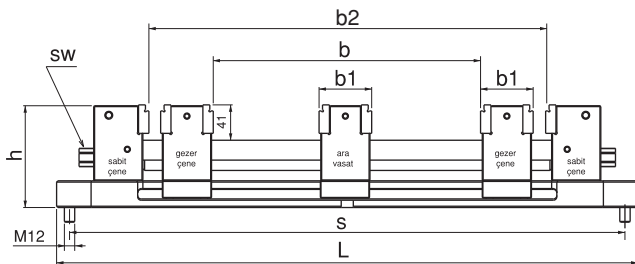

Referenz-Nr. Order No.	Spannmengen / Volume Workholding				
	1 Werkstück 1 Workpiece	2 Werkstück 2 Workpiece	3 Werkstück 3 Workpiece	4 Werkstück 4 Workpiece	5 Werkstück 5 Workpiece
2375-092					
2375-092	92	15	-	-	-
2375-192	192	66	23	-	-
2375-342	342	140	73	39.5	-
2375-442	442	190	106.5	64.5	39

Eigenschaft: Alle Anwendungen mit einer Bewegung spannen / All applications feature a single motion-Tightening

Form
Figure

1

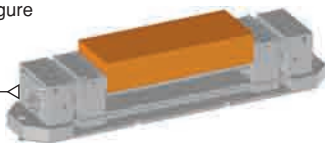

Spannen 1 Werkstück
Figure clamping 1 piece

Form
Figure

4

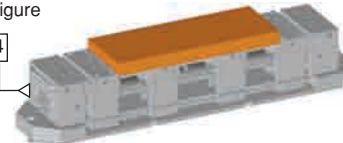

Spannen empfindlicher
Teile auf Parallelen
Figure clamping thin workpiece
on motion parallels

Form
Figure

2

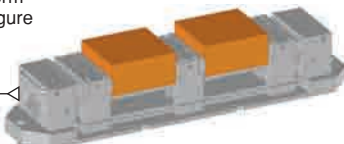

Spannen 2 Werkstücke
Figure clamping 2 peaces

Form
Figure

5



Mehrfachspannen
Figure multiple clamping

Form
Figure

3



System: Zusätzliche einseitige Spannerweiterungstoleranz von 2 mm beim Spannen des Werkstücks
System: Onesided added clamping tolerance 2 mm on clamping of the workpiece
Konstante Backen,
vom Zentrum nach außen spannen
Figure based on fixed jaw clamping
from centre in outward

Form
Figure

6

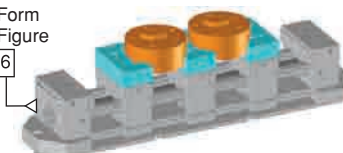

Spannen mit Weichbacken
Figure clamping with soft legs

Schraubstock Anwendung

Vise Applications

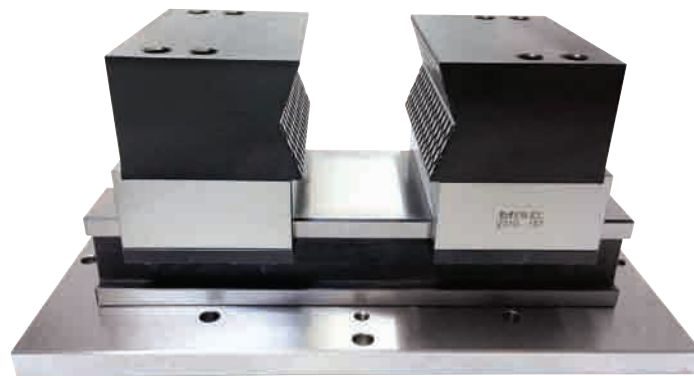

Referenz-Nr. Order No.	d	d1	h	h1	L	 (kg)
2385-130	48	32	91	60	151	3.05



2385

- Präzision 0,01 Bearbeitung Durchmesser 9-130 mm und Tiefe 170 mm

2385

- It works with 0.01 sensitivity in diameter 9-130 mm and 145 mm depth. Because of replaceable function kater and cartouche it is perfect in using.

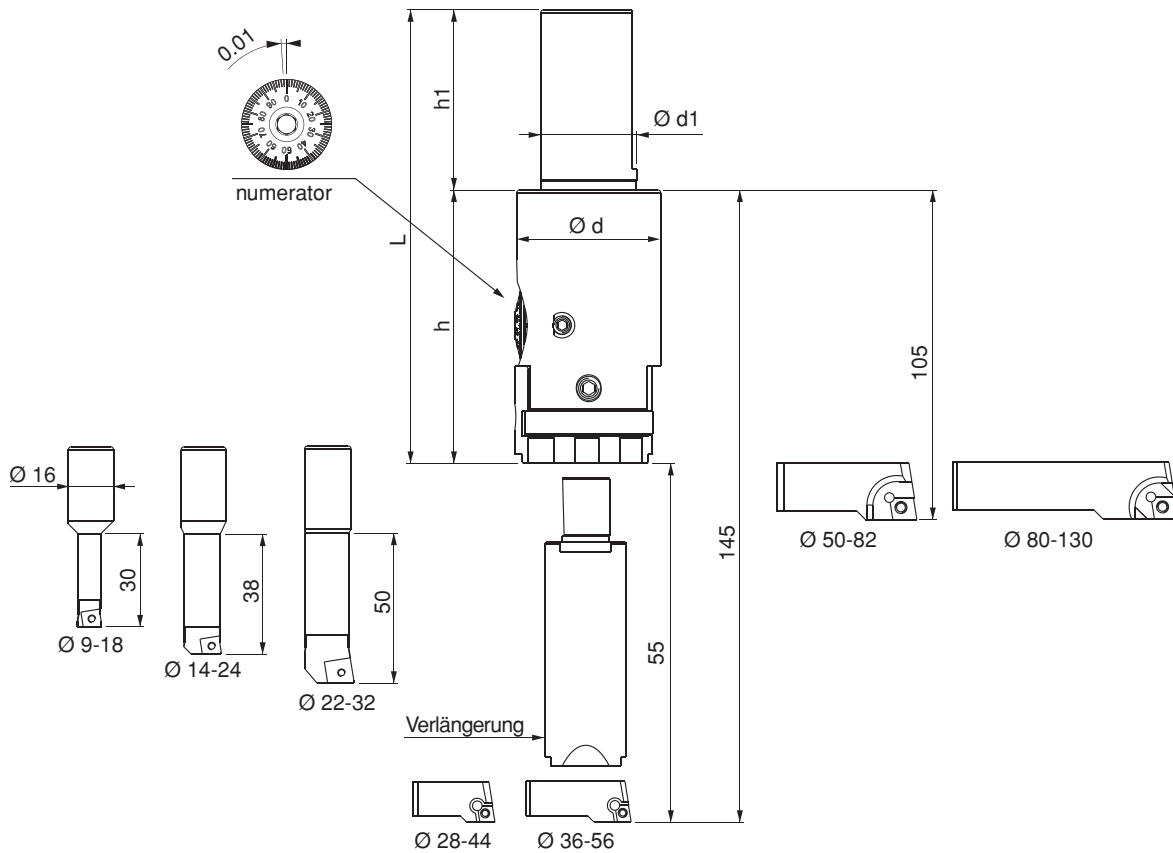

Hinweis :
ab 52 mm Durchmesser
kann mit dem
Grundkörper 105 mm
Tiefe und mit Verlängerung
eine Tiefe von 145 mm
erreicht werden

Referenz-Nr. Order No.	Type	Einsatz-Type Type of Inserts	Rotation	Progress	ap
2386-00918	09-18 Einsatz	CCMT 06	2700 d/dk.	F 75	0.1 - 0.5 mm
2386-01424	14-24 Einsatz	CCMT 06	2500 d/dk.	F 75	0.1 - 0.5 mm
2386-02232	22-32 Einsatz	CCMT 09	2000 d/dk.	F 50	0.1 - 1 mm
2386-02844	28-44 Kartusche	CCMT 06	1800 d/dk.	F 60	0.1 - 1 mm
2386-03656	36-56 Kartusche	CCMT 06	1500 d/dk.	F 65	0.1 - 1.5 mm
2386-05082	50-82 Kartusche	CCMT 09	1500 d/dk.	F 70	0.1 - 2 mm
2386-80130	80-130 Kartusche	CCMT 09	360 d/dk.	F 75	2 mm
2386-00055	Verlängerung	-	400 d/dk.	F 75	1.5 mm

Note; from diameter 52: It reaches 105 mm depth with its slot and 145 mm depth with its extended kater

Referenz-Nr. Order No.	J x M	k	h	h1	e	L	L1	L2	 (g)
2390-010	ISO30-M12	83	99	35	18	85	128	26	6030
2390-015	ISO40-M16								6555
2390-020	ISO50-M24								9110
2390-025	BT40 -M16								6900
2390-030	BT50 - M24								9840
2390-035	SK40- M16								6750
2390-040	SK50- M24					8970			
2390-045	MK4 - M16					132	6180		
2390-050	MK4 Keil / wedge					6880			
2390-055	MK5 - M20					7785			
2390-060	MK5 Keil / wedge					7450			

2390

- Präzision 0,01 Bearbeitung 18-210 mm beinhaltet 4 Lochensätze und 1 Nutenräumer in Holzkiste wechselbare Einsätze: ISO 30-40; BT 40-50; SK40-50; MK4-5

2390

- Product has 0.02 machining sensitivity and it can implement processes from 18mm to 210mm. It's modular system structure provides convenience in using. It provides the possibility of using in CNC and Mechanical benches by changing the holder. The product takes place in a wooden box with it's 4 hole bar, 1 T-Slot scraper. Changeable Holders: Possibility to be used with ISO30-40-50 BT 40-50 SK40-50 MK4-5.

Referenz-Nr. Order No.	L	L1	e	Kanten Schneid-Typ Cutting Edge type	 (g)
2395-1	85	-	18	DCMT	112
2395-2	95	-	18	DCMT	130
2395-3	132	-	18	DCMT	200
2395-4	-	128	18	-	360

min	Ø	max	c1	Umdrehung / Min Revolution per minute
18		95	50	400-450
18		95	63	400-450
20		100	100	170-220



- Bei Montage der Einsätze ist Bearbeitung 18-100 mm Durchmesser und 0-100 mm Tiefe möglich
- It is possible to have enlargement from 18mm to 100mm by attaching bars to the bottom holes taking place in the slide of the product and it can go down to depth up to 0-100mm.

min	Ø	max	c2	Umdrehung / Min Revolution per minute
95		210	55	90-170
95		210	65	90-170



- Bei Montage der Zwischeneinsätze ist Bearbeitung Durchmesser 95-210 mm und Tiefe 0-65 mm möglich
- By applying intermediary means to the side hole of the product's slide, it is possible to have enlargement from 95mm to 210mm and it can go down to depth up to 0-65mm as seen in the figure.



Es ist modular aufgebaut. Befestigung erfolgt durch im Uhrzeigersinn in den Prozess zu schrauben.

It is modular. Fixing process is done screwing towards clockwise

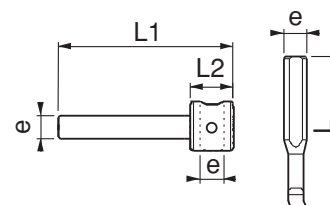
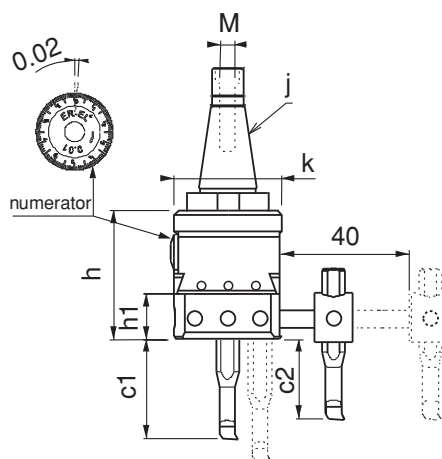

Referenz-Nr. Order No.	ISO	d	d1	L	L1	m	
2410-3016	ISO 30	16	48	125	17	M12	665
2410-3022	ISO 30	22	48	125	19	M12	760
2410-3027	ISO 30	27	48	125	21	M12	790
2410-3032	ISO 30	32	63.5	125	22	M12	1020
2410-4016	ISO 40	16	63.5	153	17	M16	1170
2410-4027	ISO 40	27	63.5	153	19	M16	1360
2410-4032	ISO 40	32	63.5	153	24	M16	1605
2410-4040	ISO 40	40	73.5	153	27	M16	1795
2410-5016	ISO 50	16	98	195	17	M24	3250
2410-5022	ISO 50	22	98	195	19	M24	3350
2410-5027	ISO 50	27	98	195	21	M24	3400
2410-5032	ISO 50	32	98	195	24	M24	3590
2410-5040	ISO 50	40	98	195	27	M24	3750

2410 ISO 30-40-50

- Gehärtet
- Fein geschliffen

2410 ISO 30-40-50

- Hardened
- Sensitive Grinding

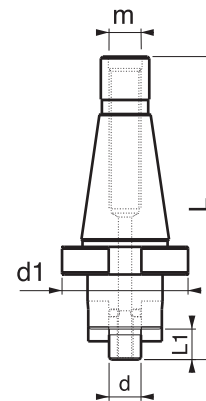

Werkzeugaufnahme

Milling Machine Hatching Headpiece Holder

Referenz-Nr. Order No.	MK	d	d1	L	L1	m	
2415-0416	MK 4	16	40	168	17	M16	945
2415-0422	MK 4	22	48	168	19	M16	1010
2415-0427	MK 4	27	53	168	21	M16	1135
2415-0432	MK 4	32	63.5	168	24	M16	1255
2415-0516	MK 5	16	63.5	208	17	M20	2145
2415-0522	MK 5	22	63.5	208	19	M20	2375
2415-0527	MK 5	27	63.5	208	21	M20	2360
2415-0532	MK 5	32	63.5	208	24	M20	2500
2415-0540	MK 5	40	73.5	208	27	M20	2700

2415 MK4-MK5

- Gehärtet
- Fein geschliffen

2415 MK4-MK5

- Hardened
- Sensitive Grinding

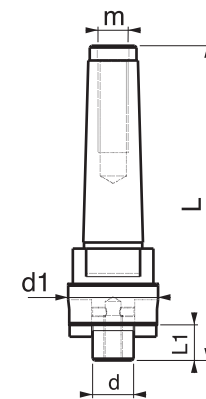

Fräskopf

Milling Machine Hatching Headpiece

Referenz-Nr. Order No.	d	h	d1	p	e		Kanten Schneid-Typ Cutting Edge type	
2420-0403	40	44	16	8.5	16	3	TPKN	230
2420-0503	50	44	22	10.5	16	3	TPKN	310
2420-0633	63	44	22	10.5	16	3	TPKN	410
2420-0634	63	44	22	10.5	16	4	TPKN	480
2420-0804	80	52	32	14.5	22	4	TPKN	800
2420-1005	100	52	32	14.5	22	5	TPKN	1320

2420

- Gehärtet
- Schwarz beschichtet

2420

- Hardened
- Black Coating

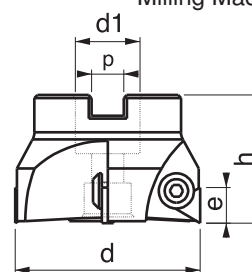

Referenz-Nr. Order No.	d	Gewinde Thread	Allen
2420-06	40-50-63	M6x0.75	4
2420-08	80-100	M8x1	5

2420

- Gehärtet
- Schwarz beschichtet

2420

- Hardened
- Black Coating



Montage und unterschiedliche Anwendungen

Mounting and Various Applications

Mehrfachspanner eine Richtung

One Direction Clamping of Multi Jawed Wrench Tooling

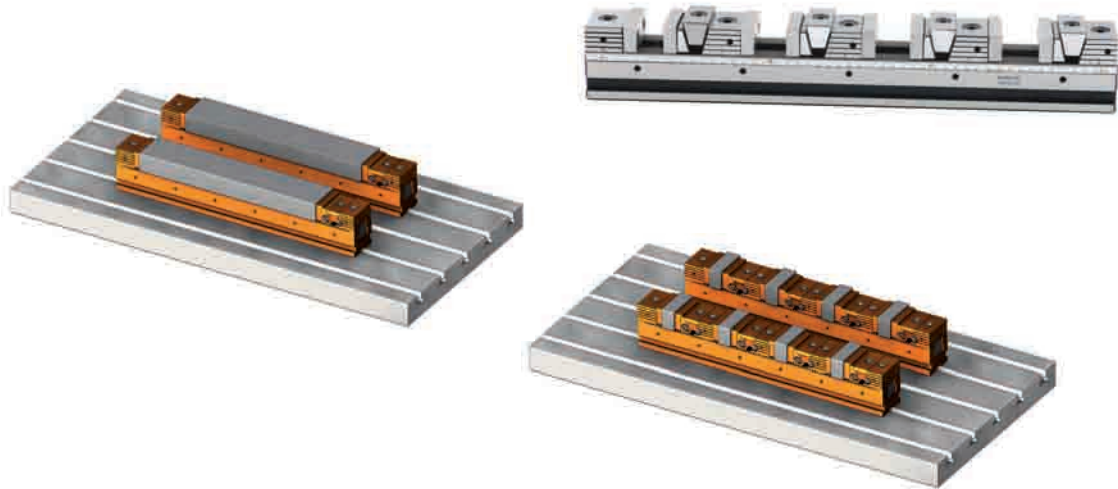

Mehrfachspanner beide Richtungen

Two Direction Clamping of Multi Jawed Wrench Tooling

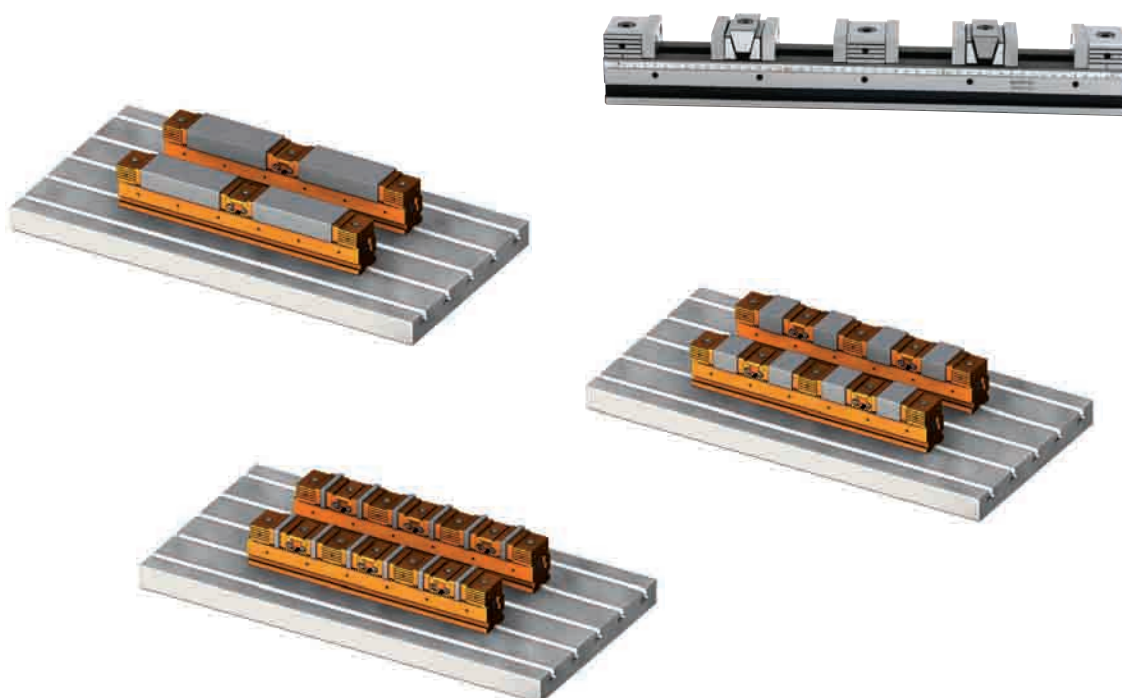

Referenz-Nr. Order No.	L	n	h1	h2	h	o	e	f	b	c	k	i	p H7	Spannmenge Coupling Piece	Spannkraft clamping force kgf	Drehmoment Allowable Screw Torque (N·m)	(kg)
2430-055300	300	55	50	32	72	12.5	36	65	100	50	100	100	18	2	1750	25	9
2430-055500	500	55	50	32	72	12.5	36	65	100	50	100	300	18	4			15
2430-075400	400	75	65	37	102	12.5	48	77	100	50	100	200	18	2	2000	35	20
2430-075600	600	75	65	37	102	12.5	48	77	100	50	100	400	18	4			33
2430-100400	400	100	65	37	102	12.5	48	80	100	50	100	200	18	2	2500	50	27
2430-100600	600	100	65	37	102	12.5	48	80	100	50	100	400	18	3			41

2430

- Spannen mehrerer Werkstücke möglich
- Formanpassung möglich
- Feinbeschichtung
- Backen müssen separat bestellt werden.

2430

- It provides the attachments of more than one workpieces to the product. Jaws are modular and can be adjusted to the desired measurement.
- Form of the workpiece can be applied on the soft legs connected to the groups.
- Sensitive Grinding
- You need to purchase jaws separate.

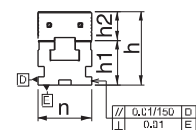
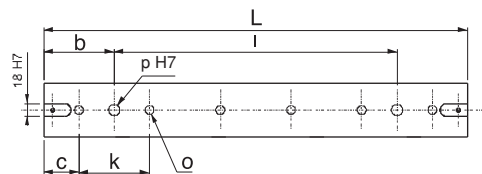
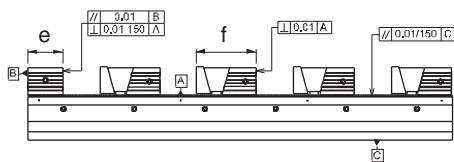

Referenz-Nr. Order No.	Spannmengen / Numbers of Portable Jaw with Workpiece Couplings				
	1 Werkstück 1 Workpiece	2 Werkstück 2 Workpiece	3 Werkstück 3 Workpiece	4 Werkstück 4 Workpiece	5 Werkstück 5 Workpiece
2430-055300	196mm	65mm	22mm	-	-
2430-055500	394mm	165mm	88mm	50mm	26mm
2430-075400	268mm	95mm	38mm	-	-
2430-075600	472mm	197mm	106mm	60mm	32mm
2430-100400	265mm	93mm	35mm	-	-
2430-100600	469mm	195mm	103mm	57mm	30mm

Hinweis: Bei den Werkstückmaßen sind die weichen Backen nicht inkludiert. **Note:** It does not include binding units of measure soft feet in business.



Referenz-Nr. Order No.	L	n	h1	h2	h	o	e	f	b	c	k	i	p H7	Spannkraft Clamping Force Kgf	Drehmoment Allowable Screw Torque (N-m)
2435-055300	300	55	50	32	82	12.5	32	37	100	50	100	100	18	1750	25
2435-055500	500	55	50	32	82	12.5	32	37	100	50	100	300	18		
2435-075400	400	75	65	37	102	12.5	37	57	100	50	100	200	18	2000	35
2435-075600	600	75	65	37	102	12.5	37	57	100	50	100	400	18		
2435-100400	400	100	65	37	102	12.5	37	57	100	50	100	200	18	2500	50
2435-100600	600	100	65	37	102	12.5	37	57	100	50	100	400	18		

2435

- Spannt doppelseitig
- Backen müssen separat bestellt werden.

2435

- Double Opening
- You need to purchase jaws separate.

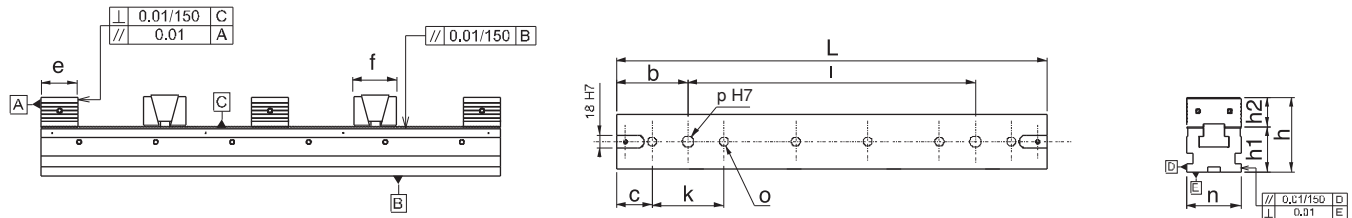

Referenz-Nr. Order No.	Spannmengen / Numbers of Double Opening Jaw with Workpiece Couplings		
	2 Werkstück 2 Workpiece	3 Werkstück 3 Workpiece	4 Werkstück 4 Workpiece
2435-055300	75mm	37mm	16mm
2435-055500	173mm	103mm	66mm
2435-075400	107mm	55mm	28mm
2435-075600	209mm	123mm	79mm
2435-100400	104mm	53mm	26mm
2435-100600	206mm	121mm	77mm
	5 Werkstück 5 Workpiece	6 Werkstück 6 Workpiece	7 Werkstück 7 Workpiece
2435-055300	-	-	-
2435-055500	45mm	30mm	20mm
2435-075400	13mm	-	-
2435-075600	54mm	45mm	24mm
2435-100400	12mm	-	-
2435-100600	52mm	34mm	22mm

Hinweis: Bei den Werkstückmaßen sind die weichen Backen nicht inkludiert.

Note: It does not include binding units of measure soft feet in business.



Referenz-Nr. Order No.	a	b	c
2430-24350551	55	14	34
2430-24350751	75	14	39
2430-24351001	100	14	39

- Gehärtet
- Vernickelt
- Hardened
- Nickel Coating

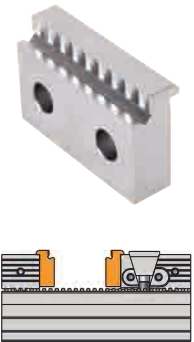
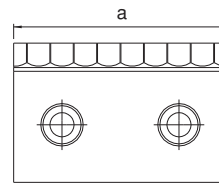
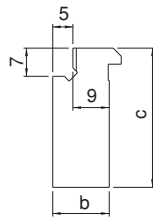

Referenz-Nr. Order No.	a	b	c
2430-24350552	53	14	34
2430-24350752	73	14	39
2430-24351002	98	14	39

- Gehärtet
- Vernickelt
- Hardened
- Nickel Coating

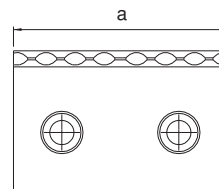
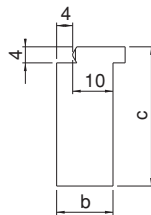

Referenz-Nr. Order No.	a	b	c	d
2430-24350553	53	22	34	17
2430-24350753	73	25	39	20
2430-24351003	98	25	39	20

- Gehärtet
- Vernickelt
- Hardened
- Nickel Coating

2430-24350551
2430-24350751
2430-24351001

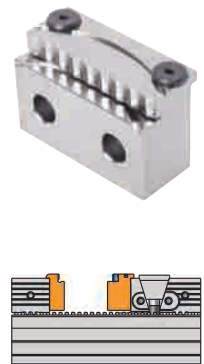
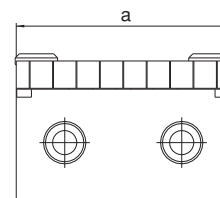
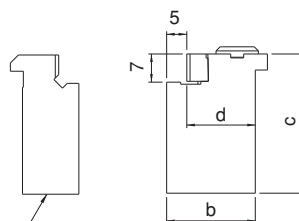

Referenz-Nr. Order No.	a	b	c
2430-24350554	53	19	34
2430-24350754	73	19	39
2430-24351004	98	19	39

- Gehärtet
- Vernickelt
- Hardened
- Nickel Coating

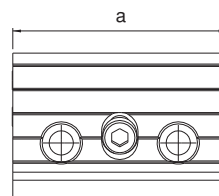
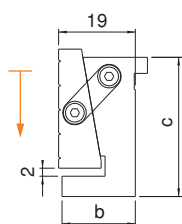

Referenz-Nr. Order No.	a	b	c
2430-24350555	53	14	34
2430-24350755	73	14	39
2430-24351005	98	14	39

Weiche Backen für Mehrfachspanner
Serial Vice Soft Jaw

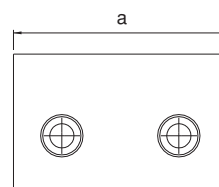

Referenz-Nr. Order No.	a	b	c
2430-2435055300AG	55	300	50
2430-2435055500AG	55	500	50
2430-2435075400AG	75	400	65
2430-2435075600AG	75	600	65
2430-2435100400AG	100	400	65
2430-2435100600AG	100	600	65

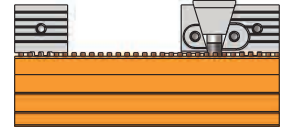
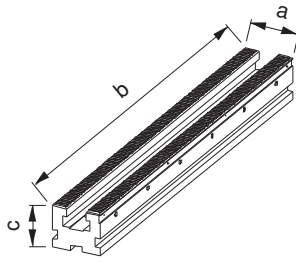

Mehrfachspanner Grundkörper
Serial Vice Sub-Body

Referenz-Nr. Order No.	a	b	c
2430-2435055GÇ	54	65	32
2430-2435075GÇ	74	77	37
2430-2435100GÇ	99	80	37

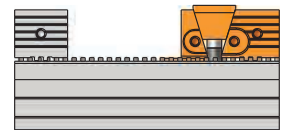
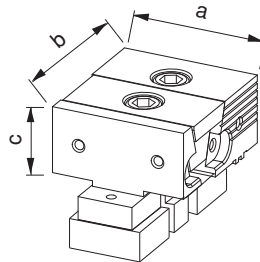

Mehrfachspanner bewegliche Backe
Serial Vice Portable Jaw

Referenz-Nr. Order No.	a	b	c
2430-2435055DA	54	36	32
2430-2435075DA	74	48	37
2430-2435100DA	99	48	37

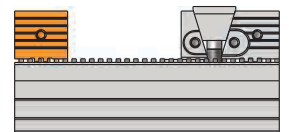
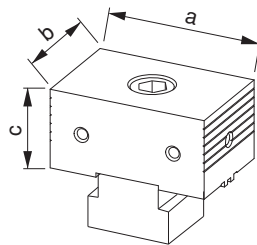

Mehrfachspanner feste Backe
Serial Vice Resting

Referenz-Nr. Order No.	a	b	c
2430-2435055ÇA	54	36	32
2430-2435075ÇA	74	48	37
2430-2435100ÇA	99	48	37

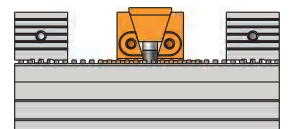
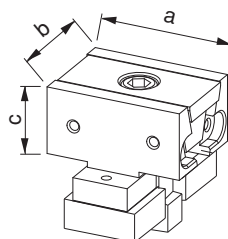

Keilspanner
Serial Vice Double Opening

Das modulare Mehrfachspannsystem

Serial Vice

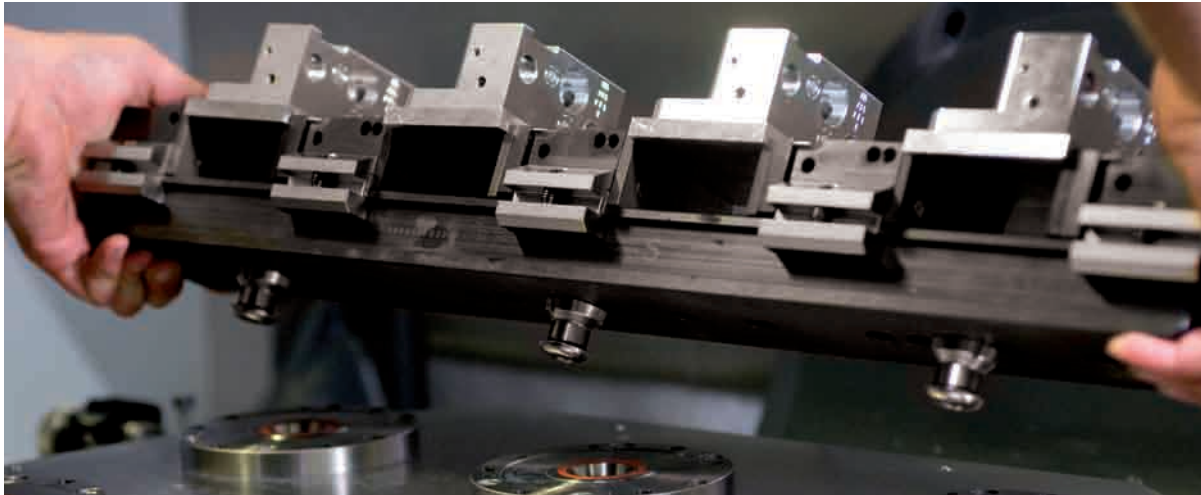
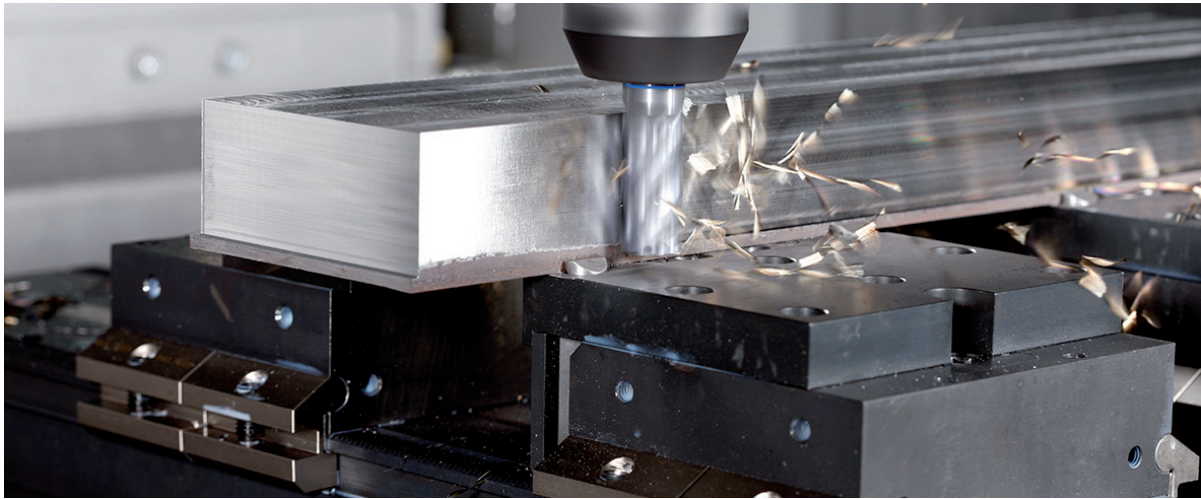

Referenz-Nr. Order No.	a	b	c	d
2440-SL080400	35	400	80	0-289
2440-SL080500	35	500	80	0-389
2440-SL080600	35	600	80	0-489

2440

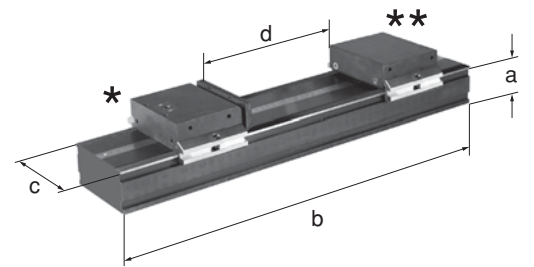

bewegliche Backen / Portable Jaw Types



Stütze / Stopper Types



Das modulare Mehrfachspannsystem

Referenz-Nr. Order No.	a	b	c	d
2440-SL120300	60	300	120	0-90
2440-SL120600	60	600	120	0-390
2440-SL120800	60	800	120	0-590

2440

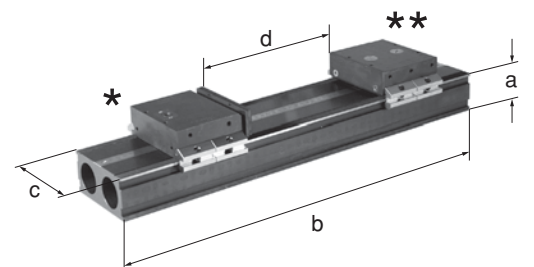

bewegliche Backen / Portable Jaw Types



Stütze / Stopper Types

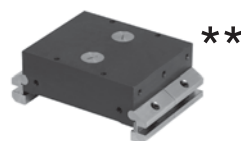

Werkstückanschlag fest

Referenz-Nr. Order No.
2440-SL80120

2440



Referenz-Nr. Order No.	L	n	n1	h	h1	h2	o	e	f	a	b	c	k	i	p H7	Spannmenge Coupling Piece	Stroke	Spannkraft Clamping Force Kgf
2443-055300	300	125	55	148	105	43	12.5	38	81.5	100	50	100	100	200	18	1	8	750
2443-055500	500	125	55	148	105	43	12.5	38	81.5	100	100	150	200	300	18	2	8	750
2443-075400	400	175	75	158	115	43	12.5	48	88	150	50	100	200	300	18	2	8	1100
2443-075600	600	175	75	158	115	43	12.5	48	88	150	100	150	300	400	18	-	8	1100
2443-100400	400	175	100	158	115	43	12.5	48	88	150	50	100	200	300	18	2	8	1100
2443-100600	600	175	100	158	115	43	12.5	48	88	150	100	150	300	400	18	-	8	1100

2443

- Bitte geben Sie vor dem Kauf die Anzahl der zu spannenden Werkstücke an.
- Backen müssen separat bestellt werden.

2443

- Please, you specify about number of clamping before you make purchase.
- You need to purchase jaws separate.

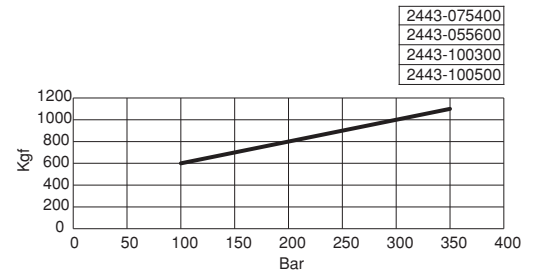
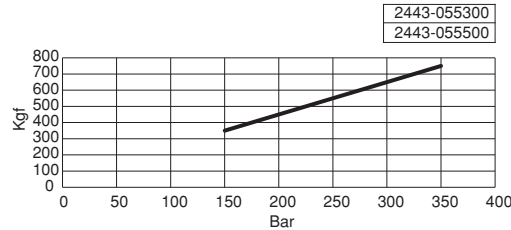
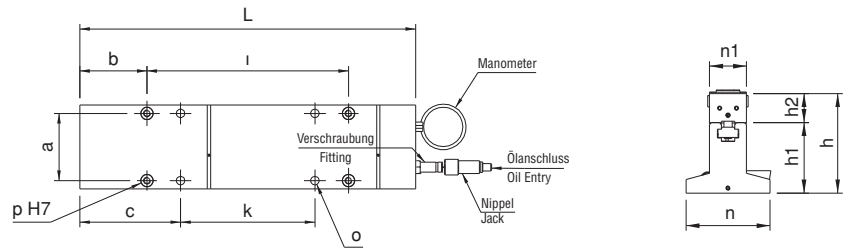
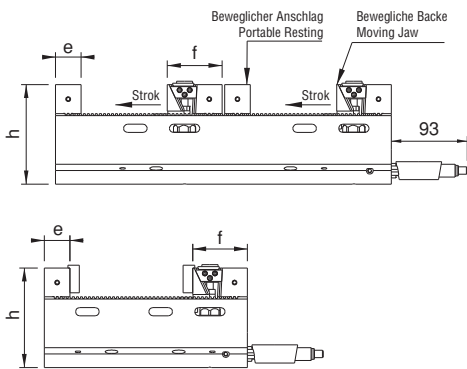
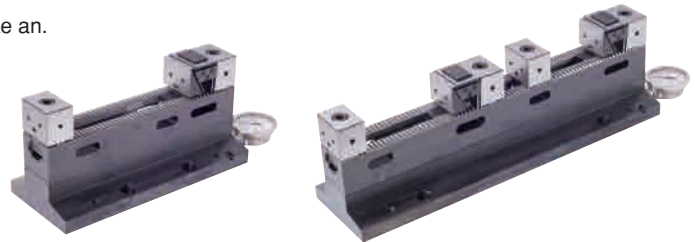

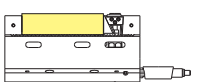
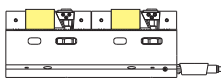
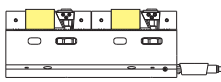
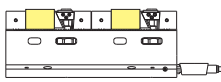
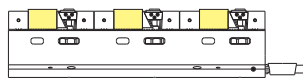
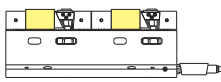
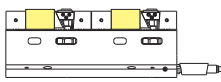
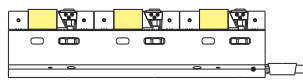
Referenz-Nr. Order No.	Spannmengen / Numbers of Portable Jaw with Workpiece Couplings		
	1 Werkstück 1 Workpiece	2 Werkstück 2 Workpiece	3 Werkstück 3 Workpiece
2443-055300	 182 mm	-	-
2443-055500	-	 128 mm	-
2443-075400	-	 68 mm	-
2443-075600	-	 170 mm	 68 mm
2443-100400	-	 68 mm	-
2443-100600	-	 170 mm	 68 mm

Hinweis: Bei den Werkstückmaßen sind die weichen Backen nicht inkludiert.

Note: It does not include binding units of measure soft feet in business.



Referenz-Nr. Order No.	L	n	n1	h	h1	h2	o	e	f	a	b	c	k	i	p H7	Spannmenge Coupling Piece	Stroke	Spannkraft Clamping Force Kgf
2445-055300	300	125	55	148	105	43	12.5	38	51.5	100	50	100	100	200	18	2	8x2	750
2445-055500	500	125	55	148	105	43	12.5	38	51.5	100	100	150	200	400	18	4	8x2	750
2445-075400	400	175	75	158	115	43	12.5	48	51.5	150	50	100	200	300	18	2	8x2	1100
2445-075600	600	175	75	158	115	43	12.5	48	51.5	150	100	150	300	500	18	4	8x2	1100
2445-100400	400	175	100	158	115	43	12.5	48	51.5	150	50	100	200	300	18	2	8x2	1100
2445-100600	600	175	100	158	115	43	12.5	48	51.5	150	100	150	300	500	18	4	8x2	1100

2445

• Backen müssen separat bestellt werden.

2445

• You need to purchase jaws separate.

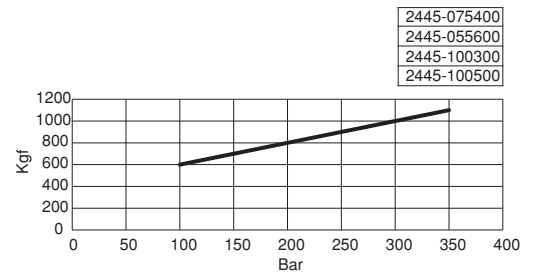
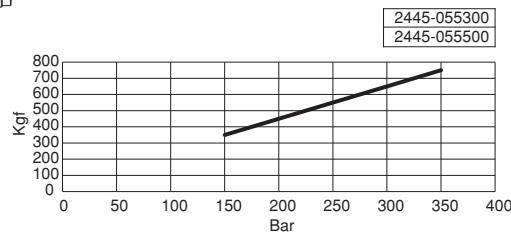
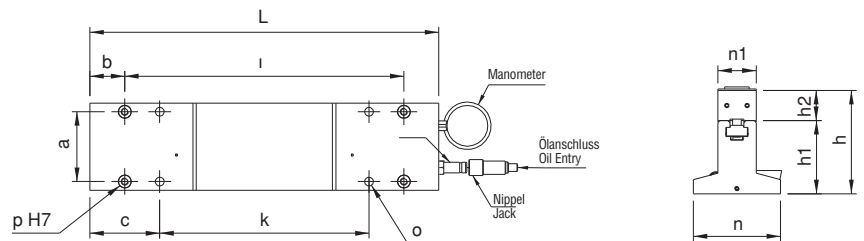
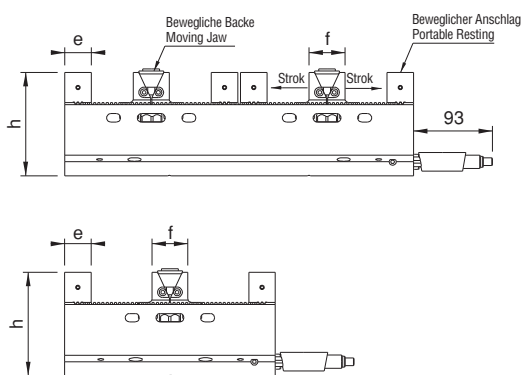

Referenz-Nr. Order No.	Spannmengen Numbers of Double Opening Jaw with Workpiece Couplings	
	2 Werkstück 2 Workpiece	4 Werkstück 4 Workpiece
2445-055300	87 mm	-
2445-055500	-	60 mm
2445-075400	125 mm	-
2445-075600	-	75 mm
2445-100400	125 mm	-
2445-100600	-	75 mm

Hinweis: Bei den Werkstückmaßen sind die weichen Backen nicht inkludiert.

Note: It does not include binding units of measure soft feet in business.



Referenz-Nr. Order No.	a	b	c
2443-24450551	55	14	38
2443-24450751	75	14	38
2443-24451001	100	14	38

- Gehärtet
- Vernickelt
- Hardened
- Nickel Coating

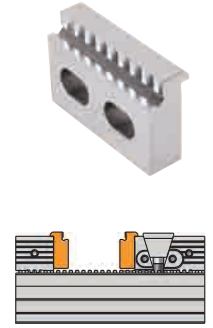
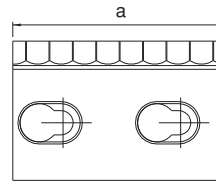
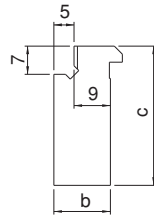

Referenz-Nr. Order No.	a	b	c
2443-24450552	55	14	38
2443-24450752	75	14	38
2443-24451002	100	14	38

- Gehärtet
- Vernickelt
- Hardened
- Nickel Coating

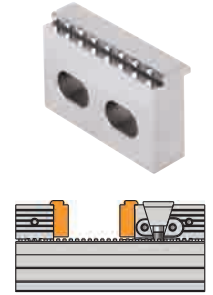
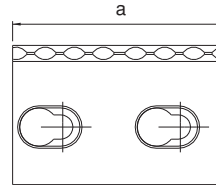
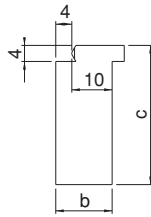

Referenz-Nr. Order No.	a	b	c	d
2443-24450553	55	22	38	17
2443-24450753	75	25	38	20
2443-24451003	100	25	38	20

- Gehärtet
- Vernickelt
- Hardened
- Nickel Coating

2443-24450551
2443-24450751
2443-24451001

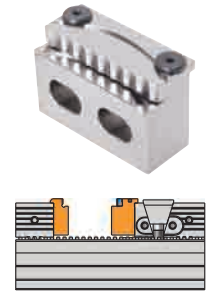
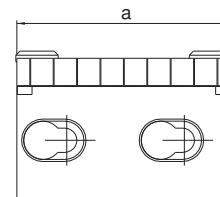
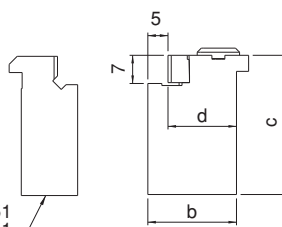

Referenz-Nr. Order No.	a	b	c
2443-24450554	55	19	38
2443-24450754	75	19	38
2443-24451004	100	19	38

- Gehärtet
- Vernickelt
- Hardened
- Nickel Coating

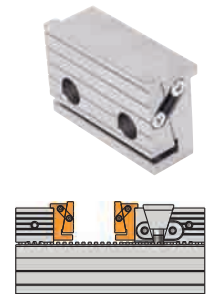
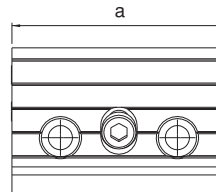
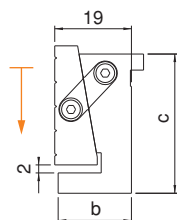

Referenz-Nr. Order No.	a	b	c
2443-24450555	55	14	38
2443-24450755	75	14	38
2443-24451005	100	14	38

Weiche Backe Soft Jaw

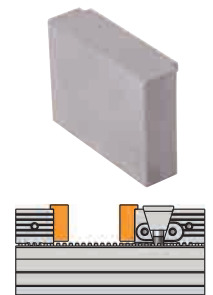
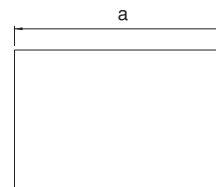
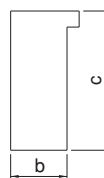

Referenz-Nr. Order No.	a	b	c
2443-24450556	55	14	38
2443-24450756	75	14	38
2443-24451006	100	14	38

Weiche Backe Soft Jaw

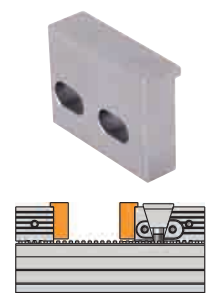
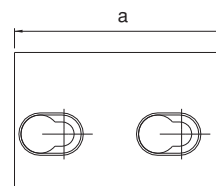
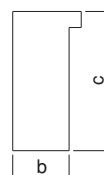

Referenz-Nr. Order No.	a	b	c	e
2443-055300AG	55	300	105	125
2443-055500AG	55	500	105	125
2443-075400AG	75	400	115	175
2443-075600AG	75	600	115	175
2443-100400AG	100	400	115	175
2443-100600AG	100	600	115	175

Hydraulischer Grundkörper
Hydraulic Sub-body

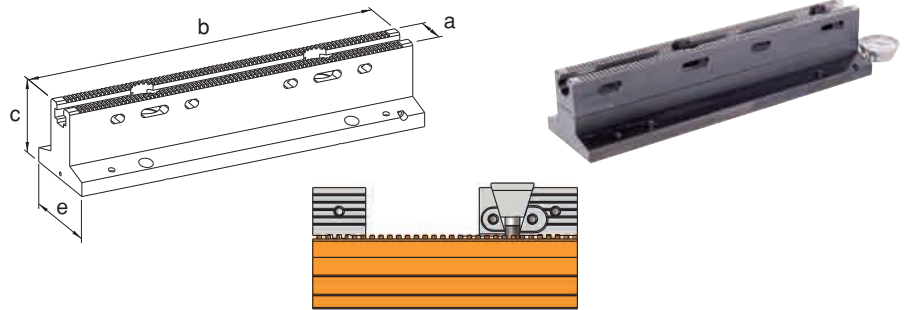

Referenz-Nr. Order No.	a	b	c
2443-055HÇ	55	81.5	43
2443-075HÇ	75	88	43
2443-100HÇ	100	88	43

Bewegliche Backe
Moving Jaw

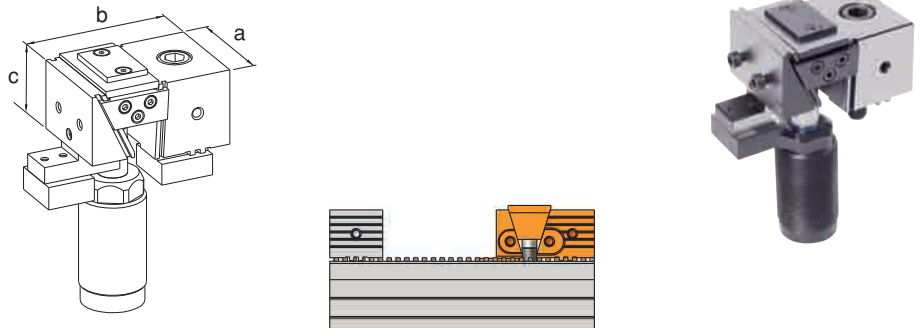

Referenz-Nr. Order No.	a	b	c
2443-055MHÇ	55	81.5	43
2443-075MHÇ	75	88	43
2443-100MHÇ	100	88	43

Magnetische bewegliche Backe
Moving Jaw

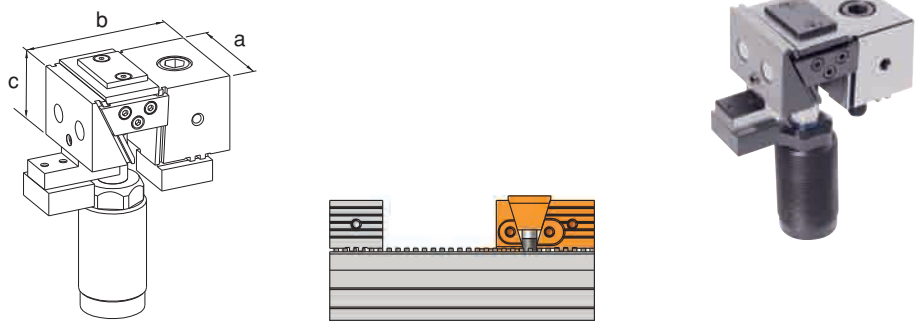

Referenz-Nr. Order No.	a	b	c
2443-2445055GD	55	38	43
2443-2445075GD	75	48	43
2443-2445100GD	100	48	43

Beweglicher Anschlag
Portable Resting

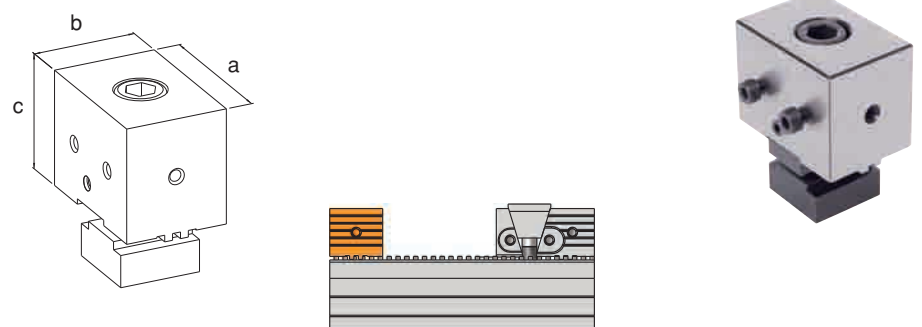

Referenz-Nr. Order No.	a	b	c
2443-2445055MGD	55	38	43
2443-2445075MGD	75	48	43
2443-2445100MGD	100	48	43

Magnetischer beweglicher Anschlag
Magnetic Portable Resting

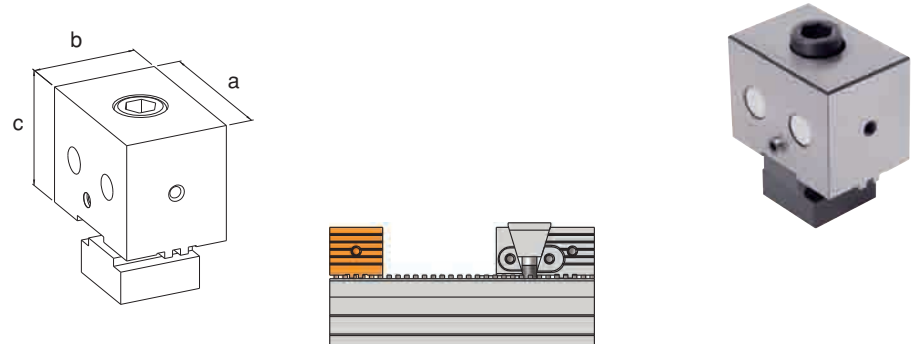

Referenz-Nr. Order No.	a	b	c	e
2445-055300AG	55	300	105	125
2445-055500AG	55	500	105	125
2445-075400AG	75	400	115	175
2445-075600AG	75	600	115	175
2445-100400AG	100	400	115	175
2445-100600AG	100	600	115	175

Hydraulischer Grundkörper
Hydraulic Sub-body

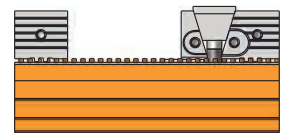
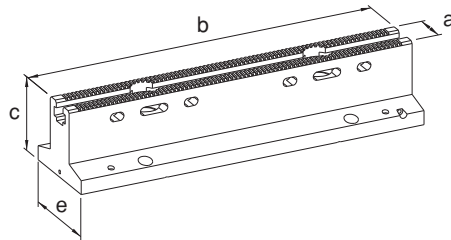

Referenz-Nr. Order No.	a	b	c
2445-055HÇ	55	51.5	43
2445-075HÇ	75	51.5	43
2445-100HÇ	100	51.5	43

Bewegliche Backe
Moving Jaw

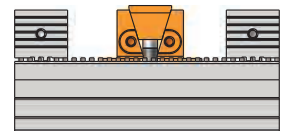
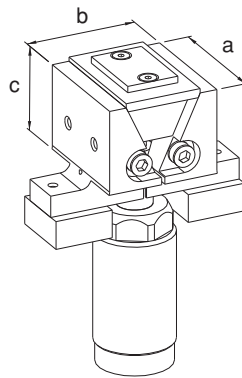

Referenz-Nr. Order No.	a	b	c
2445-055MHÇ	55	51.5	43
2445-075MHÇ	75	51.5	43
2445-100MHÇ	100	51.5	43

Magnetische bewegliche Backe
Moving Jaw

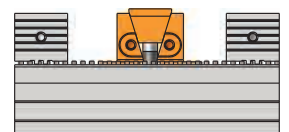
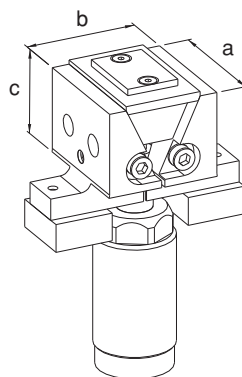

Hydraulisches Zubehör

Hydraulic Equipment

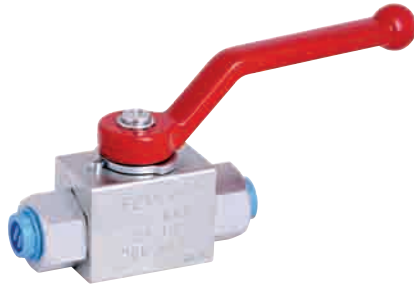

Spannbalken

Index Table Turrets

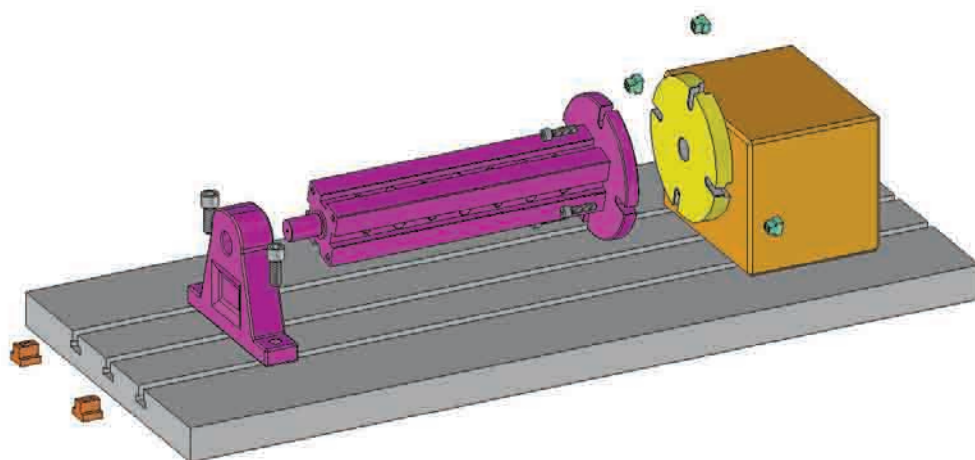
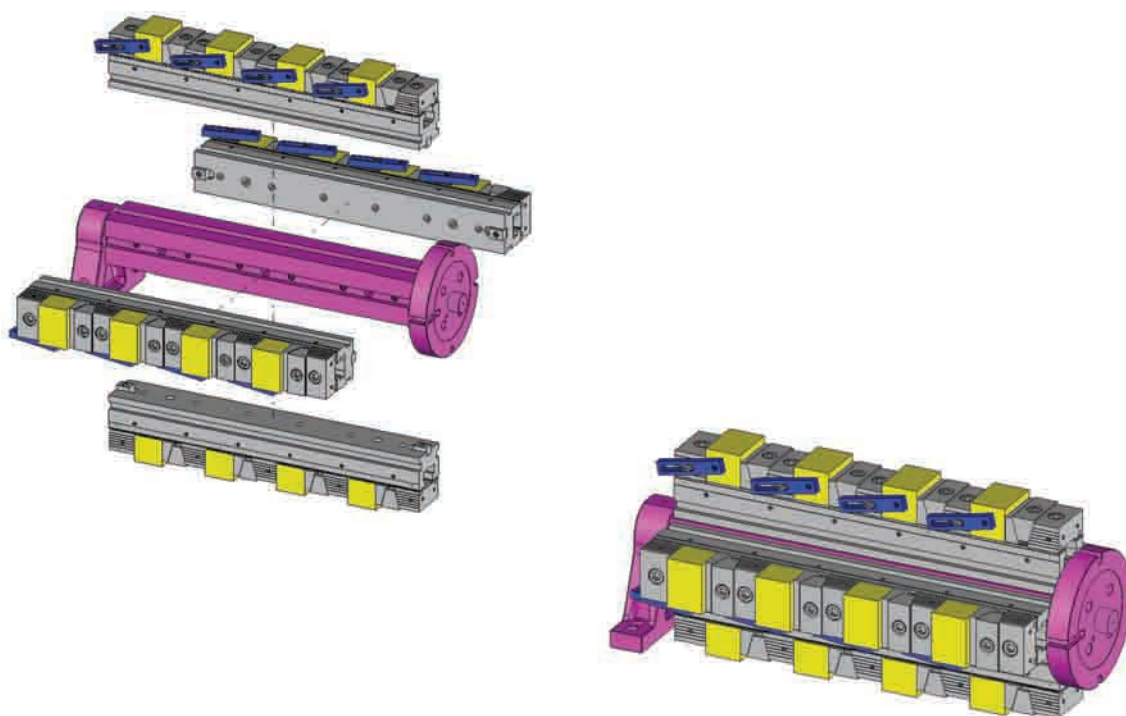

Referenz-Nr. Order No.	L	l	f	n	b	k	c	e	s	Ø16H7 j	Ø16H7 j1	(kg)
2450-415L	503.5	415	45	-	125	35	31	30	72	100	100	29.25
2450-615L	703.5	615	50	-	160	35	31	30	90	100	300	46.75

2450

- Verwendung bei vertikalen Maschinen, vierte Achse Bearbeitung 360 Grad möglich
- Spannen der Werkstücke direkt am Divisor möglich, kompatibel mit Schraubstocksystemen und unsterschiedlichen Apparaten
- Benachrichtigen Sie Ihre divizörü Marke und Modellnummer bei der Bestellung.
- Die untere Platte ist für die mittlere Höhe zur Verfügung.
- Material: Guss

2450

- Index Table Turret is connected to the index table of vertical machining benches and this application provides the possibility to use the fourth axis in 360 degrees.
- Workpiece taking place on the Index Table Turret can be applied directly and at the same time it can be used in vice groups and with different apparatuses.
- Please, let the dividing brand, model number in the order.
- The lower plate is available for the center height.
- Material : Casting

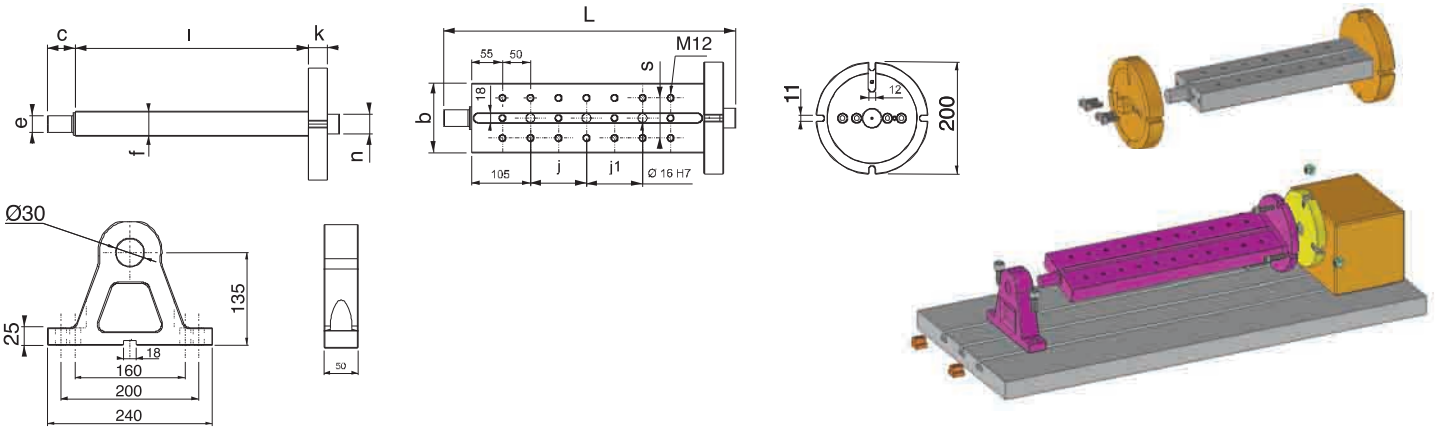

Einsatz = Nr.2460

Referenz-Nr. Order No.	L	l	n	k	e	c	Ø16H7 j	Ø16H7 j1	(kg)
2470-415K	502	415	-	35	30	31	100	100	33
2470-615K	702	615	-	35	30	31	100	300	42

2470

- Verwendung bei vertikalen Maschinen, vierte Achse Bearbeitung 360 Grad möglich
- Spannen der Werkstücke direkt am Divisor möglich, kompatibel mit Schraubstocksystemen und unsterschiedlichen Apparaten
- Benachrichtigen Sie Ihre divizörü Marke und Modellnummer bei der Bestellung.
- Die untere Platte ist für die mittlere Höhe zur Verfügung.
- Material: Guss

2470

- Index Table Turret is connected to the index table of vertical machining benches and this application provides the possibility to use the fourth axis with 360 degrees.
- Workpiece taking place on the Index Table Turret can be applied directly and at the same time it can be used in vice groups and with different apparatuses.
- Material : Casting

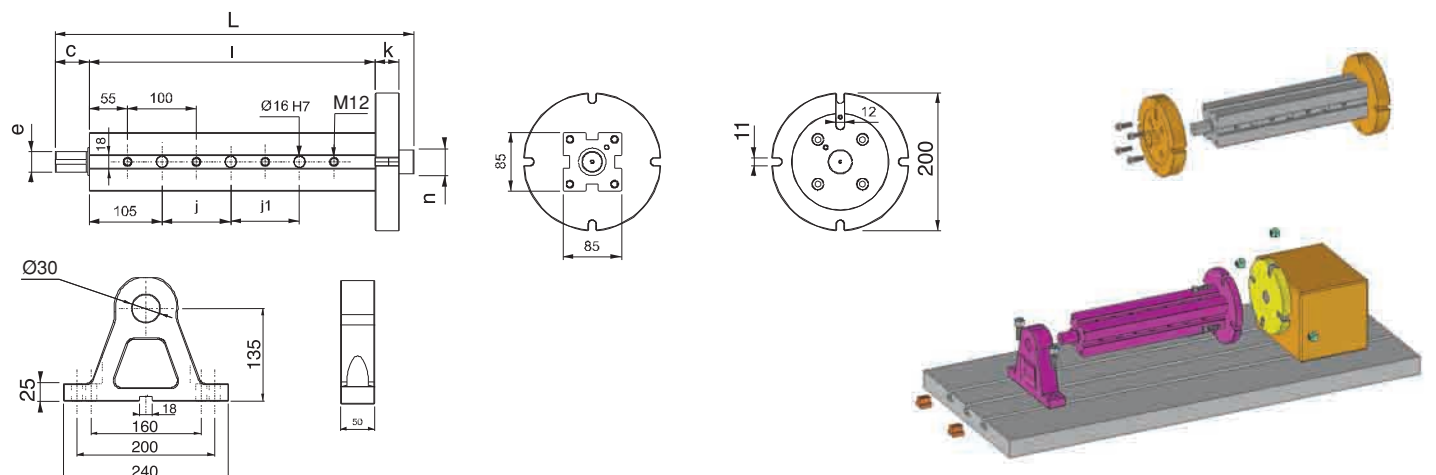

Einsatz = Nr.2460

Referenz-Nr. Order No.	a	b	c	d	Zero Clamp Menge / pcs.		Spannkraft clamping force Kgf	
2475-50400	50	400	160	200	4	Ø120	4x2500=10000 kgf	24
2475-50500	50	500	200	350	4	Ø120	4x2500=10000 kgf	30
2475-50630	50	630	250	200	6	Ø120	6x2500=15000 kgf	44

2475

- Material: Aluminium

2475

- Material: Aluminium

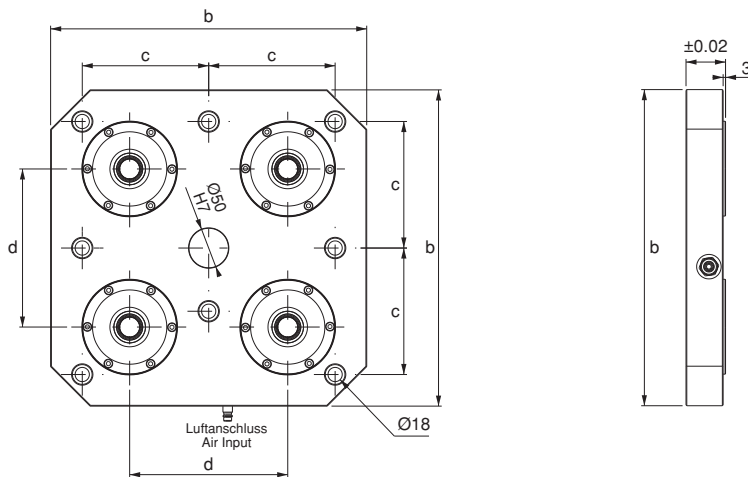
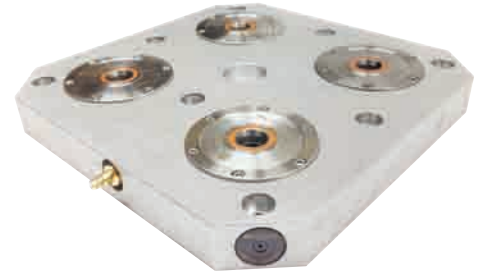

- Unterschiedliche Anwendungen möglich
- Product application area is not limited to the alues given in tables. Various applications are possible.

Turm mit Anwendung ZeroClamp

Referenz-Nr. Order No.	a	b	c	d	g	Zero Clamp Menge / pcs.		Spannbolzen Pull Stud Menge / pcs.	Spannkraft clamping force Kgf	
2480-400200	680	400	200	200	50	12	Ø120	4	3x2500=7500 kgf	100
2480-500200	680	500	200	350	50	12	Ø120	4	3x2500=7500 kgf	111
2480-630250	680	630	250	200	50	12	Ø138	6	3x4000=12000 kgf	178

2480



- Material: Aluminium

2480

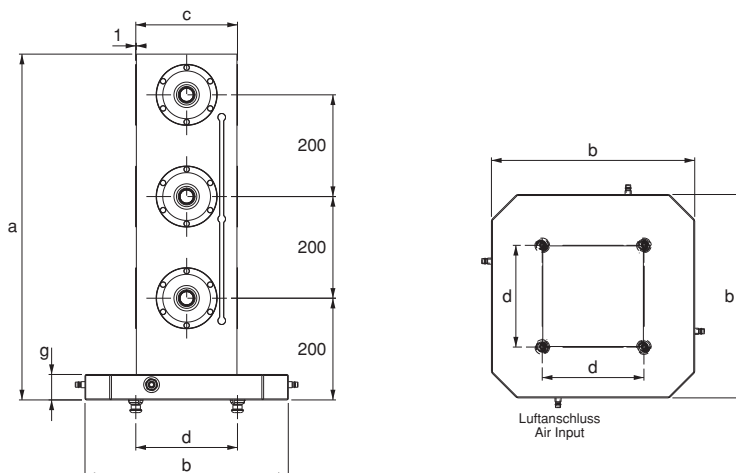
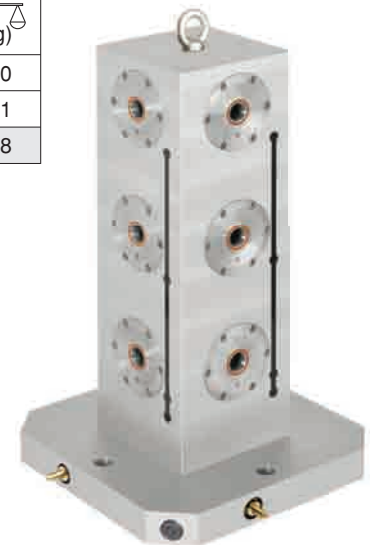
- Material: Aluminium



- Unterschiedliche Anwendungen möglich
- Product application area is not limited to the alues given in tables. Various applications are possible.

Referenz-Nr. Order No.	a	b	c	d	e		 (kg)
2481-50630	50	630	800	200	200	Ø120	60



2481

• Material: Aluminium

2481

• Material: Aluminium

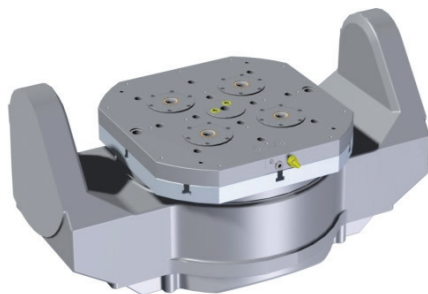
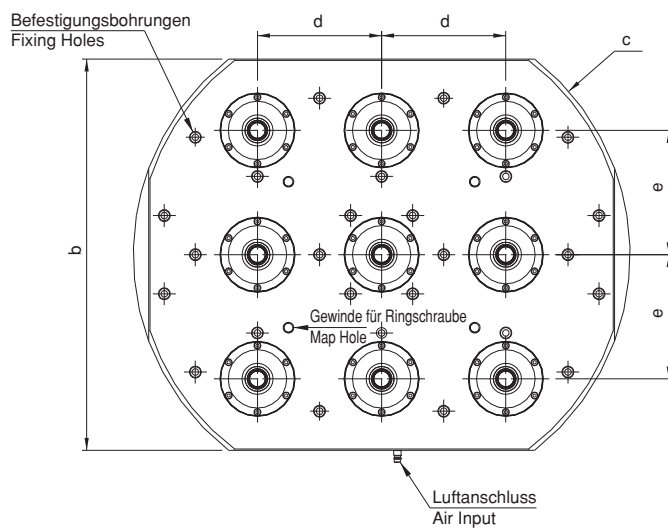
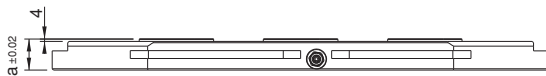

Referenz-Nr. Order No.	Spannkraft clamping force kgf	 (kg)
2482-0120	2500	13.4

2482

- Schwarz beschichtet
- Geschliffen

2482

- Black coating
- Stoning

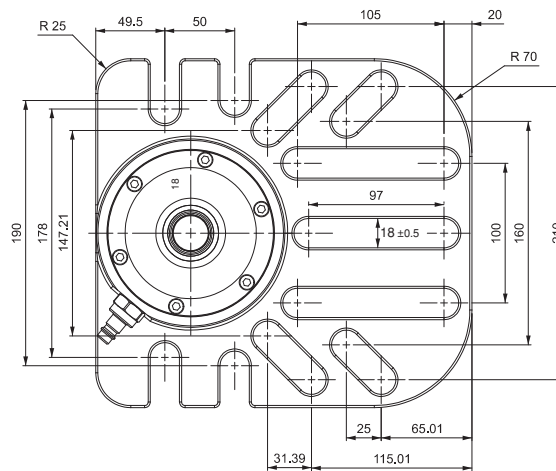
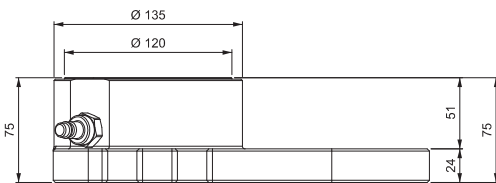
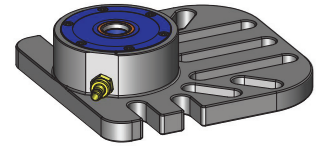

Referenz-Nr. Order No.	a	b	c	d	e	h	h1	Spannkraft clamping force kgf	 (kg)
2483-0090	105	90	220	160	13	50	36	1250	4.2
2483-0120	135	120	180	130	13	65	51	2500	8.4
2483-0138	160	138	250	200	17	80	61	4000	15.7

2483

- Schwarz beschichtet
- Geschliffen

2483

- Black coating
- Stoning

Modular Zero Clamp

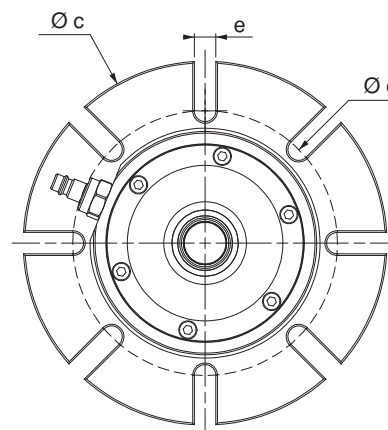
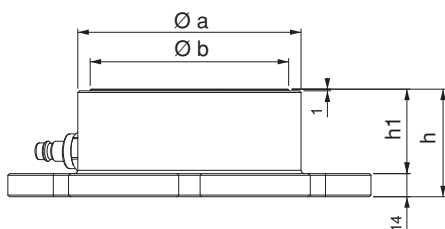
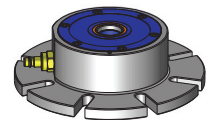

ZERO CLAMP Anwendungsbeispiele

ZERO CLAMP Application Examples

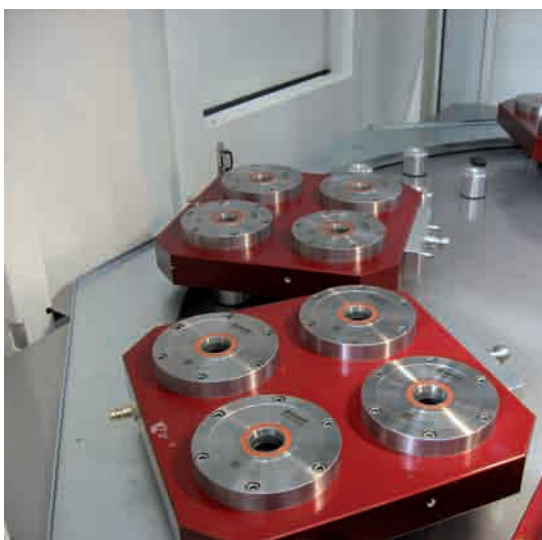
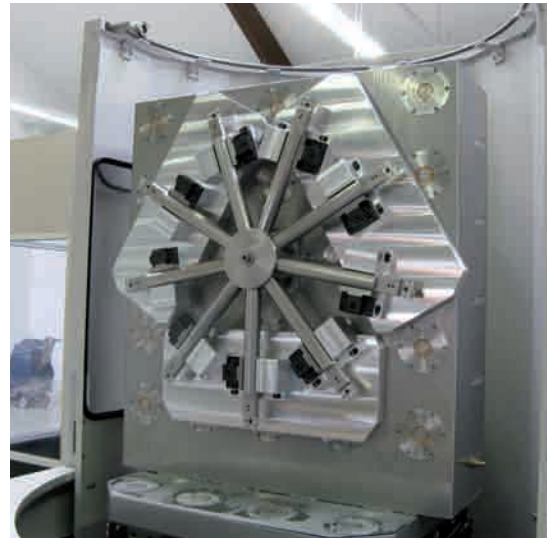
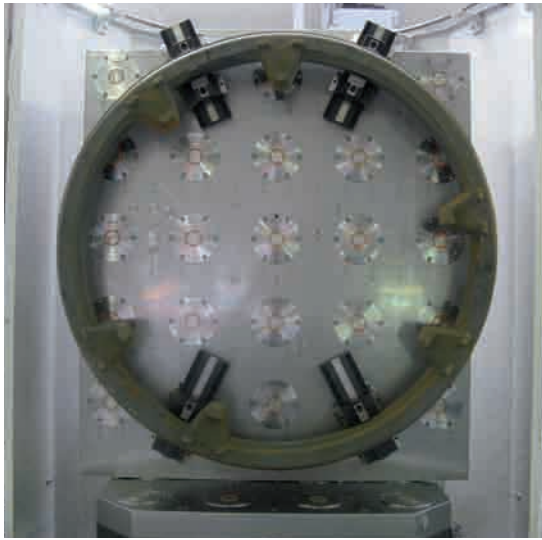

Aufspanntürme und Mehrfachspanner

Tower And Multi Jawed Wrench Tooling Applications

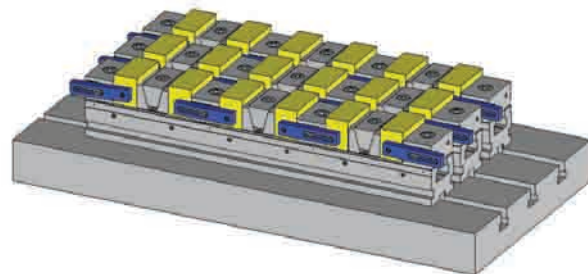
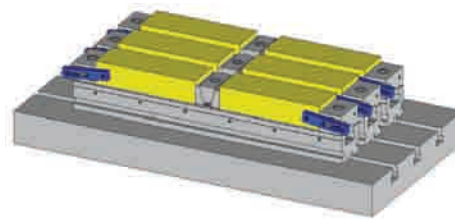
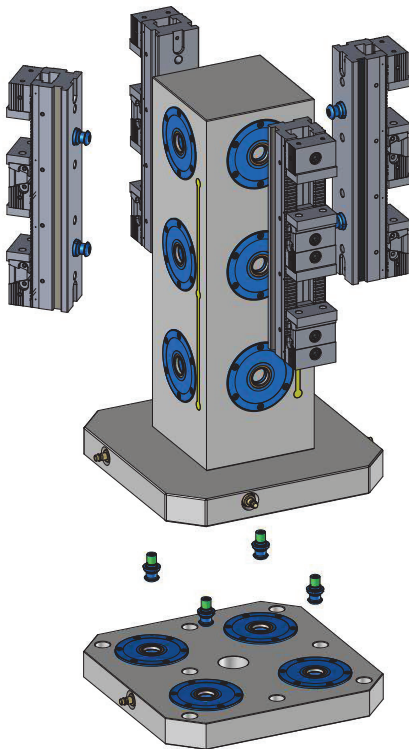
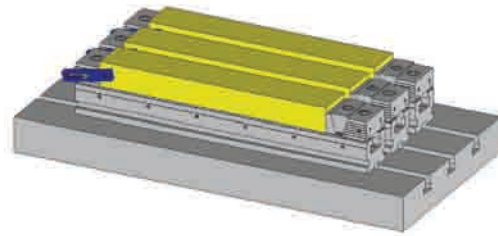
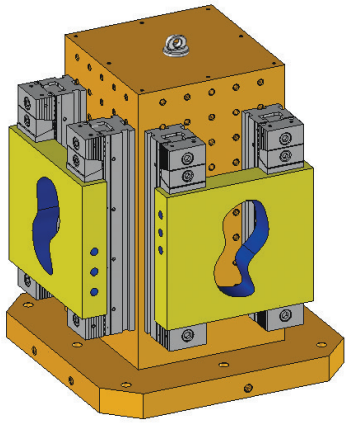

Referenz-Nr. Order No.	a ±0.02	b	c	d	e	f	g	h ±0.02	 (kg)
2490-7540014	75	400	320	14	55	18	160	80	71
2490-7550014	75	500	400	14	75	18	200	100	115
2490-7563014	75	630	500	14	100	18	250	125	188
2490-7540018	75	400	320	18	55	18	160	80	65
2490-7550018	75	500	400	18	75	18	200	100	107
2490-7563018	75	630	500	18	100	18	250	125	178

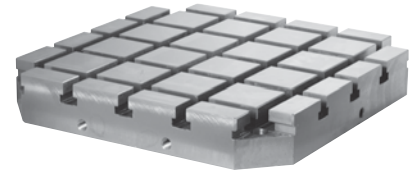

2490

- Material: Guss
- kompatibel mit Standard-Spannelementen
- T-Nuten 14 mm - 18 mm DIN 650

2490

- Material : Casting
- It is in compliance with Standard Coupling Equipment.
- T-Slot measurement of 14mm - 18mm is in DIN 650 Standard.

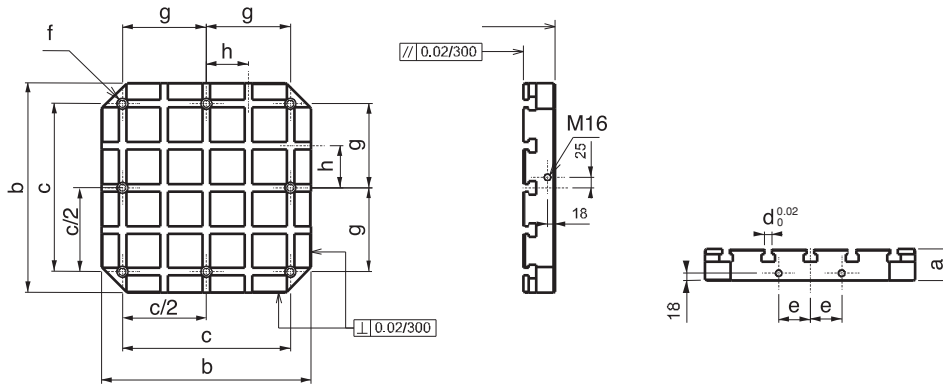

Referenz-Nr. Order No.	a ±0.02	b	c	d	e	 m	 (kg)
2510-7540012	75	400	320	55	25	M12	80
2510-7550012	75	500	400	75	25	M12	127
2510-7563012	75	630	500	100	40	M12	204
2510-7540016	75	400	320	55	25	M16	79
2510-7550016	75	500	400	75	25	M16	125
2510-7563016	75	630	500	100	40	M16	200

CNC Horizontale Aufspann-Palette

CNC Horizontal Clamping Pallet

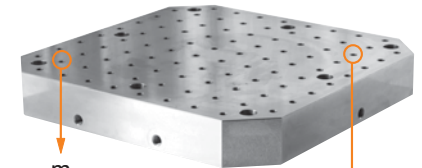

Referenz-Nr. Order No.	a ±0.02	b	c	d	e	 m	 (kg)
2520-7540012	75	400	320	55	25	M12	80
2520-7550012	75	500	400	75	25	M12	127
2520-7563012	75	630	500	100	40	M12	204
2520-7540016	75	400	320	55	25	M16	79
2520-7550016	75	500	400	75	25	M16	125
2520-7563016	75	630	500	100	40	M16	200

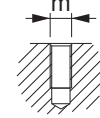

Gewindekörper
Nr. 2510
Threaded body
Reference No. 2510

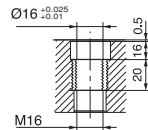
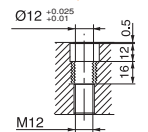

2510

- Material: Guss
- kompatibel mit Standard-Spannelementen
- M12-M16, Gewindeabstand 50 ± 0,02
- Auf Anfrage mit gehärteten Stahlbuchsen erhältlich

2510

- Material : Casting
- It is in compliance with Standard Coupling Equipment.
- M12 - M16 thread gap on it's surface is 50 ± 0.02.
- It's steel bush threads are hardened.

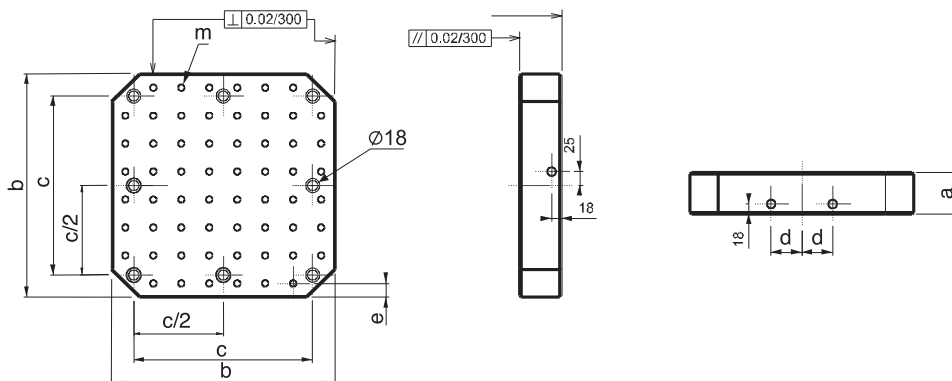

mit Stahlbuchse
Nr. 2520
Steel bush
Reference No. 2520

Referenz-Nr. Order No.	a	b	Ød	e	f	t	(kg)
2530-040012	400	600	18	-	-	M12	73
2530-050012	500	600	18	-	-	M12	112
2530-060012	600	800	18	-	-	M12	162
2530-140012	400	800	18	-	-	M12	119
2530-145012	450	900	18	-	-	M12	151
2530-150012	500	1000	18	-	-	M12	173

Referenz-Nr. Order No.	a	b	Ød	e	f	t	(kg)
2530-040016	400	600	18	-	-	M16	87
2530-050016	500	600	18	-	-	M16	108
2530-060016	600	800	18	-	-	M16	155
2530-140016	400	800	18	-	-	M16	115
2530-145016	450	900	18	-	-	M16	146
2530-150016	500	1000	18	-	-	M12	171

2530

- Material: Guss
- kompatibel mit Standard-Spannelementen
- M12-M16, Gewindeabstand $50 \pm 0,02$
- Auf Anfrage mit gehärteten Stahlbuchsen erhältlich

2530

- Material : Casting
- It is in compliance with Standard Coupling Equipment.
- M12 - M16 thread gap on it's surface is 50 ± 0.02 .
- It's steel bush threads are hardened.

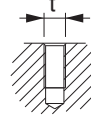
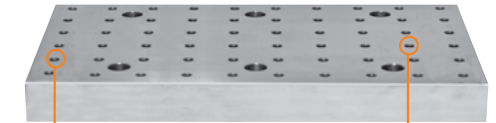
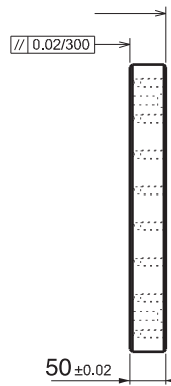
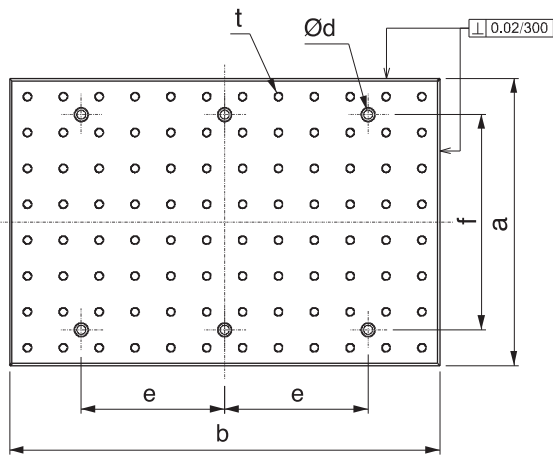

Gewindekörper
Nr. 2530
Threaded body
Reference No. 2530

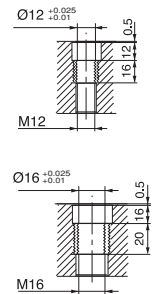

mit Stahlbuchse
= Nr. 2540
Steel bush
Reference No. 2540

CNC Vertikale Aufspann-Platte

Referenz-Nr. Order No.	a	b	c	d	e	f	Øg	h	i	j	(kg)
2550-040014	400	600	60	14	50	100	18	-	-	50	90
2550-050014	500	600	60	14	50	100	18	-	-	50	115
2550-060014	600	800	60	14	50	100	18	-	-	50	198
2550-140014	400	800	60	14	50	100	18	-	-	50	120
2550-145014	450	900	60	14	75	100	18	-	-	50	162
2550-150014	500	1000	60	14	50	100	18	-	-	50	199

Referenz-Nr. Order No.	a	b	c	d	e	f	Øg	h	i	j	(kg)
2550-040018	400	600	75	18	50	100	18	-	-	50	108
2550-050018	500	600	75	18	50	100	18	-	-	50	135
2550-060018	600	800	75	18	50	100	18	-	-	50	216
2550-140018	400	800	75	18	50	100	18	-	-	50	143
2550-145018	450	900	75	18	75	100	18	-	-	50	183
2550-150018	500	1000	75	18	50	100	18	-	-	50	225

2550

- Material: Guss
- kompatibel mit Standard-Spannelementen
- T-Nuten 14 mm - 18 mm DIN 650

2550

- Material : Casting
- It is in compliance with Standard Coupling Equipment.
- T-Slot is in the standard of 14mm - 18mm DIN 650.

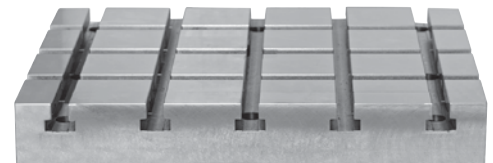
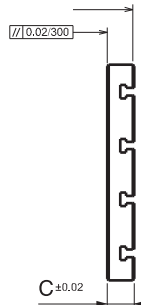
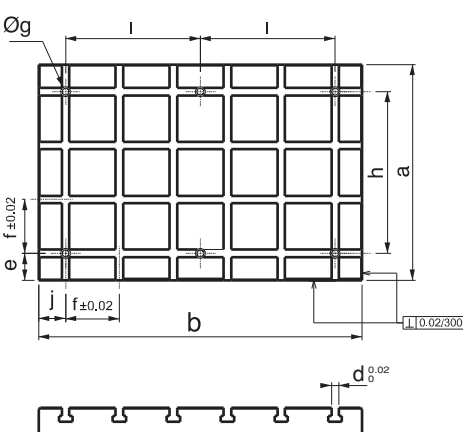

Vakuumpplatten-Anwendungen

Vacuum Plate Application

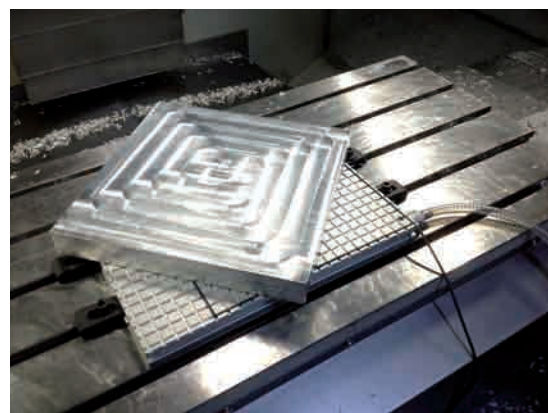
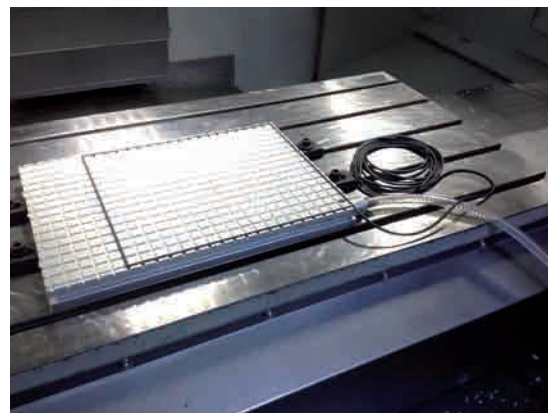
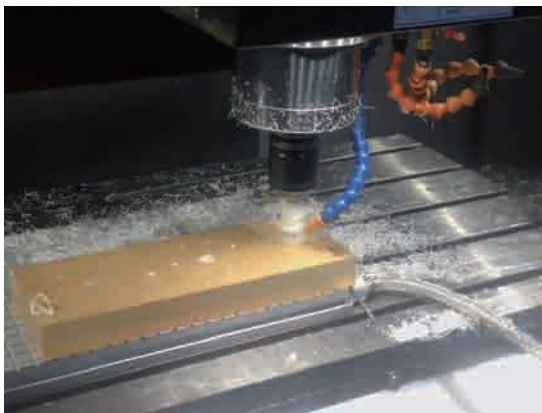
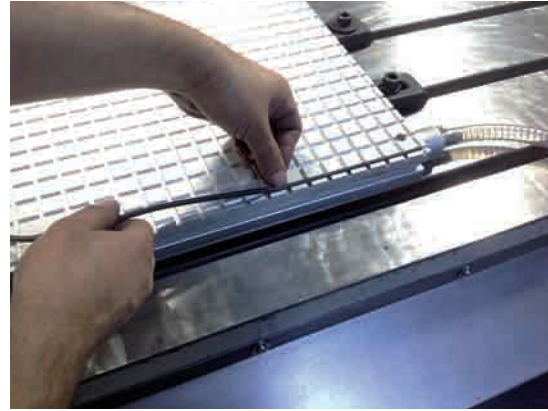
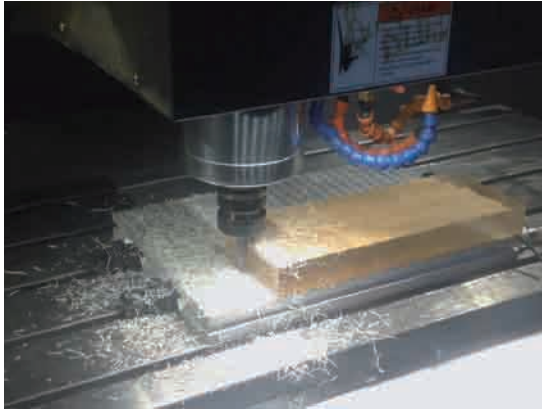

Referenz-Nr. Order No.	m ³ /h	Volt	Vakuu-Leistung vacuum power	Kw	Hz	A	B	C	 (kg)
2557-022	22	400	150-50 mbar	0.83	50	463	432	602	45.5
2557-045	45	400	150-50 mbar	1.20	50	515	572	743	57
2557-065	65	400	150-50 mbar	2.40	50	515	572	743	72
2557-100	100	400	150-50 mbar	3.85	50	525	620	920	110
2557-150	150	400	150-50 mbar	4.00	50	710	845	1100	200
2557-198	198	400	150-50 mbar	5.50	50	710	845	1100	220
2557-232	232	400	150-50 mbar	7.50	50	710	845	1100	240



2557

• Wasser und Span-Trennsystem

2557

• Water and chip parser system

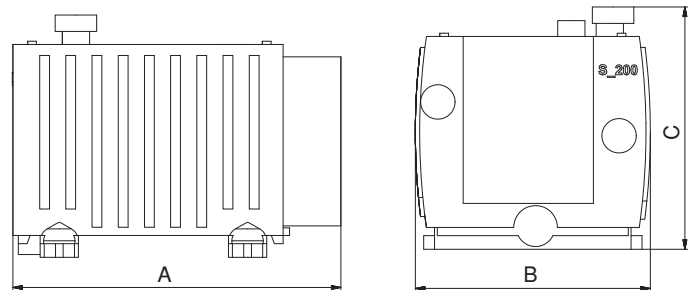

Adapterplatte

Adaption Plate

Referenz-Nr. Order No.	a	L	h
2560-200300	200	300	10
2560-300400	300	400	10
2560-400400	400	400	10
2560-400600	400	600	10
2560-600900	600	900	10

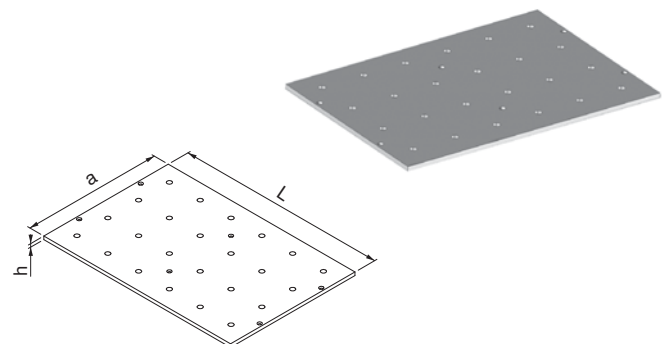

2560

blau Saugertellers

Blue Vacuum Pad

Referenz-Nr. Order No.	
2563-200300	200x300

2563



Referenz-Nr. Order No.	A	L	quadratische Fläche Square Range	Pumpeneinheit / Pump Unit		 (kg)
				Nr.	Nr.	
2565-200300	200	300	20	*2557-022	*2567-095969	6.20
2565-300400	300	400	20	*2557-022	*2567-095969	12.30
2565-400400	400	400	20	*2557-022	*2567-082105	16.40
2565-400600	400	600	20	*2557-022	*2567-082105	24.60
2565-600900	600	900	20	*2557-022	*2567-080156	55.40

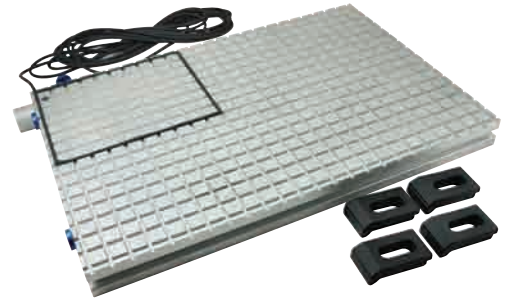

2565

- Material: Aluminium
- *Pumpenelement ist nicht enthalten, muss separat gekauft werden

2565

- Material : Aluminium
- *You need to purchase Pump unit separate.

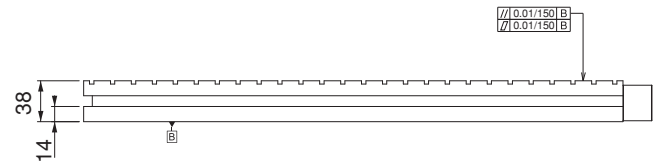
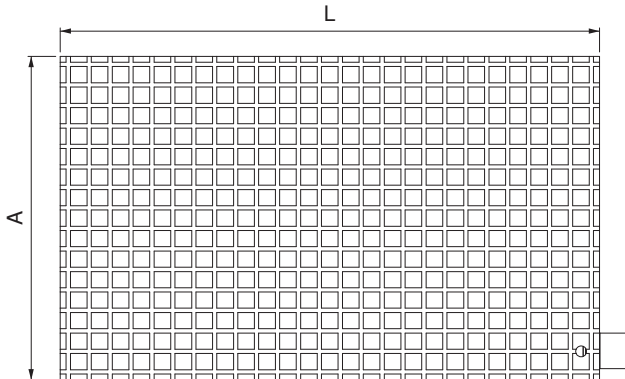

Vakuumpumpe

Vacuum Pump

Referenz-Nr. Order No.	m³/h	Volt	Hz	Vakuum-Leistung vacuum power	Kw	RPM	DB	Oil	A	B	C	D	E	F	G	 (kg)
2567-095969	10	230	50	20 mbar	0.37	3000 ¹ / _{min}	59	0.3l	301	234	297	100	83	150	M8	24
2567-281548	10	400	50	20 mbar	0.37	3000 ¹ / _{min}	59	0.3l	301	234	297	100	83	150	M8	24
2567-082115	16	230	50	20 mbar	0.55	3000 ¹ / _{min}	60	0.3l	301	234	297	100	83	150	M8	10.3
2567-082116	16	400	50	20 mbar	0.55	3000 ¹ / _{min}	60	0.3l	301	234	297	100	83	150	M8	10.3
2567-080156	21	230	50	20 mbar	0.75	3000 ¹ / _{min}	62	0.5l	401	223	254	131	127	210	M8	22
2567-080078	21	400	50	20 mbar	0.75	3000 ¹ / _{min}	62	0.5l	401	223	254	131	127	210	M8	22

2567

- Trockensystem

2567

- Dry system

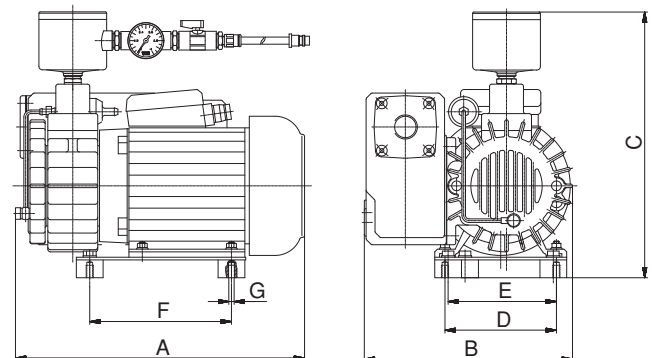

CNC Horizontalbearbeitungstürme

CNC Horizontal Clamping Cube

Werkstücke spannen mit Nr. 2310 Schraubstock beidseitig beweglich auf Nr. 2670 CNC Horizontaler Aufspannturm

Nr.2670 clamping cube with Nr.2310 vice applications

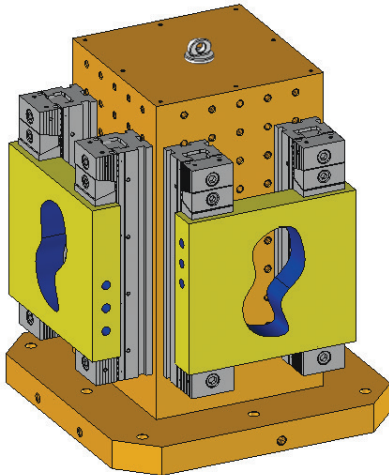
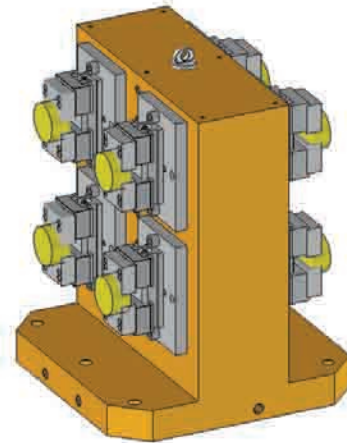

Werkstücke spannen mit Nr. 2430 Mehrfachspanner auf Nr. 2650 CNC Horizontaler Aufspannturm

Nr.2650 clamping cube with Nr.2430 vice applications

Nr. 2650 CNC Horizontaler Aufspannturm spannen auf CNC Horizontalbearbeitungszentrum-Platte

Nr.2650 clamping cube CNC Horizontal machines applications

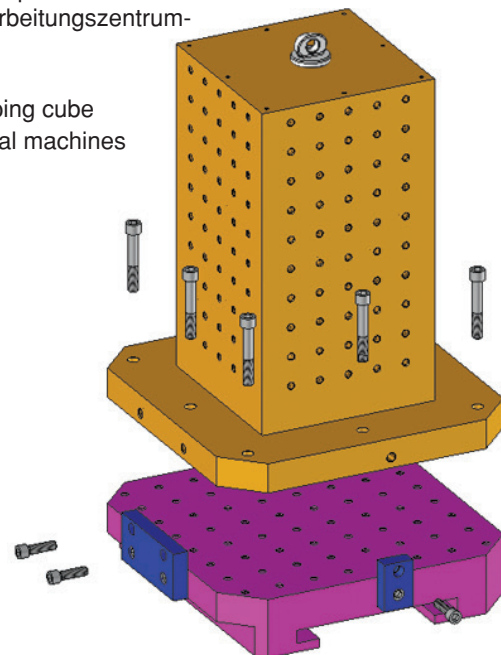
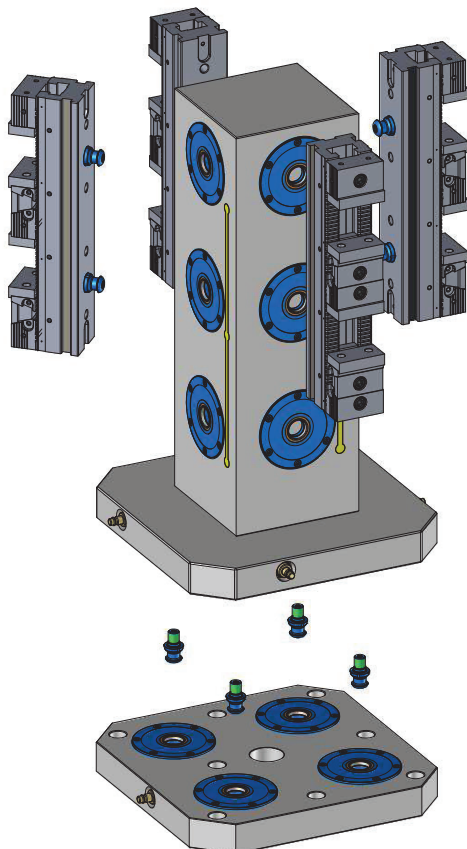

Referenz-Nr. Order No.	a	b	c	d	e	f	g	h	ØI	j	k	s	s1	(kg)
2570-30012	300	300	220	100	250	90	40	30	18	M12	75	25	170	50
2570-40012	400	400	280	160	320	90	40	30	18	M12	75	30	240	88
2570-50012	500	500	345	200	400	90	50	35	18	M12	75	35	300	175
2570-63012	630	630	435	250	500	100	50	40	18	M12	105	40	360	298
2570-30016	300	300	220	100	250	90	40	30	18	M16	75	25	170	45
2570-40016	400	400	280	160	320	90	40	30	18	M16	75	30	240	84
2570-50016	500	500	345	200	400	90	50	35	18	M16	75	35	300	170
2570-63016	630	630	435	250	500	100	50	40	18	M16	105	40	360	293

2570

- Material: Guss
- verwendbar bei horizontalen und vertikalen Bearbeitungszentren
- kompatibel mit Standard-Spannelementen
- M12-M16, Gewindeabstand 50 ± 0.02
- Auf Anfrage mit gehärteten Stahlbuchsen erhältlich

2570

- Material : Casting
- It is used in CNC Horizontal end Vertical processing benches.
- It is in compliance with Standard Coupling Equipment.
- M12 - M16 thread gap on it's surface is 50 ± 0.02.
- It's steel bush threads are hardened.

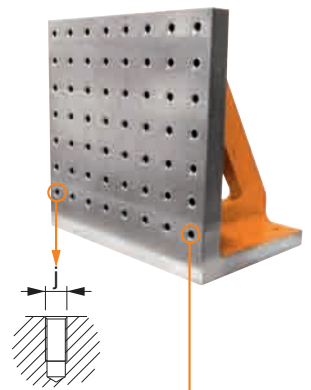

Gewindekörper
Nr. 2570
Threaded body
Reference No. 2570

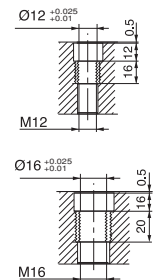
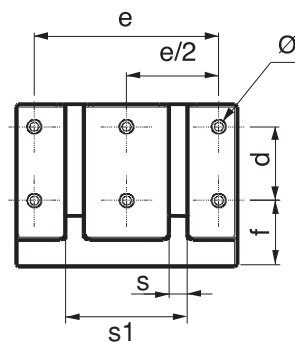
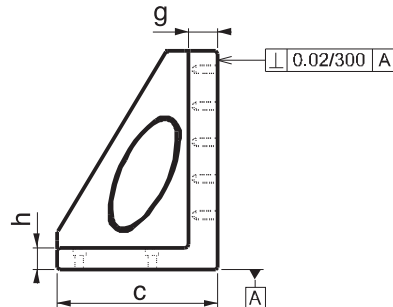
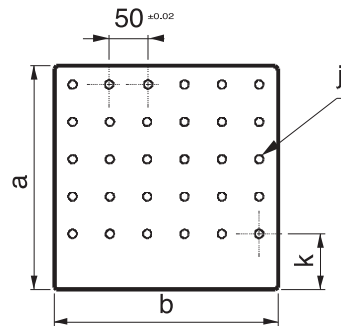

mit Stahlbuchse
Nr. 2575
Steel bush
Reference No. 2575

Referenz-Nr. Order No.	a	b	c	d	e	f	g	h	ØI	j	k	L	s	s1	(kg)
2590-30014	300	300	220	100	250	90	60	30	18	14	100	50	25	170	50
2590-40014	400	400	300	160	320	90	60	30	18	14	100	50	30	240	100
2590-50014	500	500	350	200	400	90	60	35	18	14	100	50	35	300	185
2590-63014	630	630	450	250	500	100	65	40	18	14	125	65	40	360	315
2590-30018	300	300	220	100	250	90	60	30	18	18	100	50	25	170	50
2590-40018	400	400	300	160	320	90	60	30	18	18	100	50	30	240	98
2590-50018	500	500	350	200	400	90	60	35	18	18	100	50	35	300	174
2590-63018	630	630	450	250	500	100	65	40	18	18	125	65	40	360	286

2590

- Material: Guss
- verwendbar bei horizontalen und vertikalen Bearbeitungszentren
- kompatibel mit Standard-Spannelementen
- T-Nuten 14 mm - 18 mm DIN 650

2590

- Material : Casting
- It is used in CNC Horizontal end Vertical processing benches.
- It is in compliance with Standard Coupling Equipment.
- T-Slot is in the standard of 14mm - 18mm DIN 650.

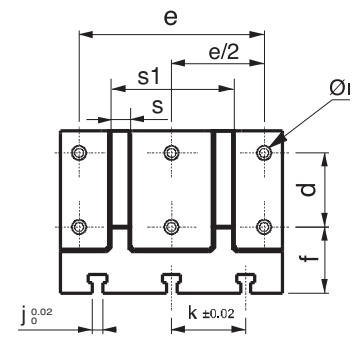
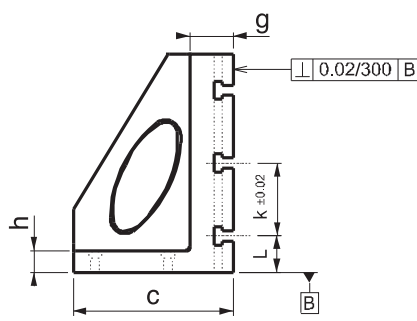
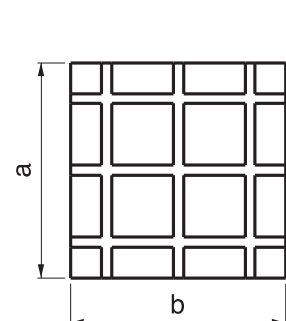

Referenz-Nr. Order No.	b	d	c	c1	A min.	A max.	Spannkraft clamping force kgf
2600-400400	400	160	320	-	-	-	4000
2600-500500	500	200	400	-	-	-	4000
2600-630630	630	250	500	-	-	-	4000

2600

- Verwendung: CNC Horizontalbearbeitung, Erleichterung bei Bearbeitung von 2 Flächen der Zylinderwerkstücke auf Bohrwerkmaschinen
- Bewegliche Fläche sind komplett feingeschliffen und gehärtet.

2600

- Application area: Provides better operation on both sides of cylinderic workpieces on cnc horizontal machines and bohrwerks.
- Entire moving surface is sensitively grinded and hardened.

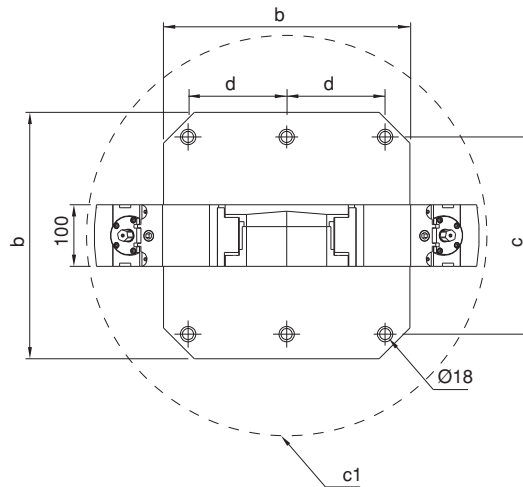
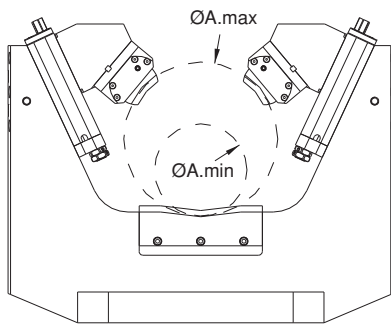

Backe mit beweglichem Kopf
Head Moving Jaw

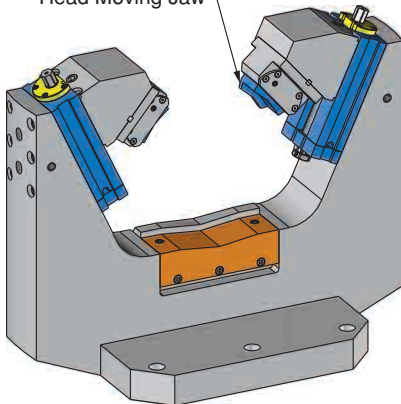

Werkstück
Workpiece

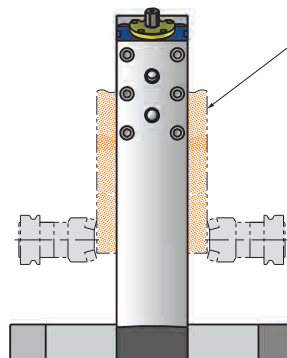

Referenz-Nr. Order No.	a	b	c	d	e	f	g	(kg)
2610-400250	500	400	250	320	200	55	50	180
2610-500300	600	500	300	400	250	75	50	240
2610-630350	700	630	350	500	315	100	50	390

2610

- Anwendung Fläche nach Bedarf
- Material: Guss

2610

- Application on the surface according to desired way.
- Material : Casting

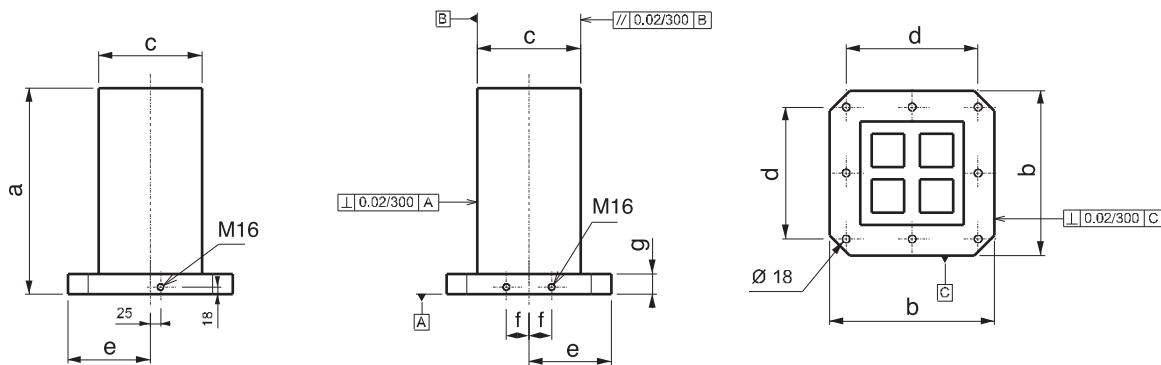
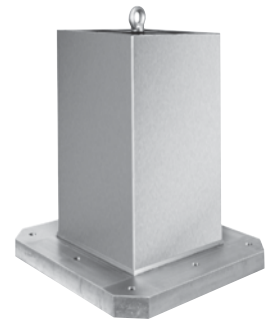

CNC Horizontaler Aufspannturm

CNC Horizontal Processing Cube

Referenz-Nr. Order No.	a	b	c	d	e	f	g	i	k	J (^{0,02})	(kg)
2630-40025014	500	400	250	320	200	55	50	150	100	14	165
2630-50030014	600	500	300	400	250	75	50	150	100	14	227
2630-63035014	700	630	350	500	315	100	50	150	125	14	375
2630-40025018	500	400	250	320	200	55	50	150	100	18	155
2630-50030018	600	500	300	400	250	75	50	150	100	18	223
2630-63035018	700	630	350	500	315	100	50	150	125	18	370

2630

- Spannen Werkstücke auf 4 Flächen möglich
- kompatibel mit Standard-Spannelementen
- T-Nuten 14 mm - 18 mm DIN 650
- Material: Guss

2630

- Workpiece can be applied on four faces.
- It is in compliance with Standard Coupling Equipment.
- T-Slot is in the standard of 14mm - 18mm DIN 650.
- Material : Casting

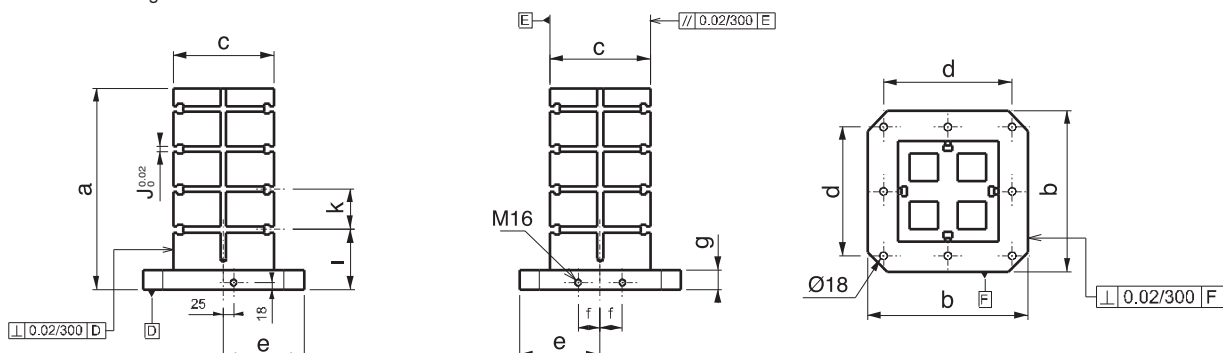
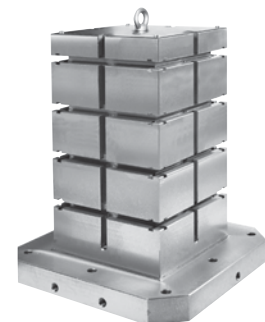

Referenz-Nr. Order No.	a	b	c	d	e	f	g		
2650-40025012	500	400	250	320	200	55	50	M12	170
2650-50030012	600	500	300	400	250	75	50	M12	230
2650-63035012	700	630	350	500	315	100	50	M12	380
2650-40025016	500	400	250	320	200	55	50	M16	168
2650-50030016	600	500	300	400	250	75	50	M16	228
2650-63035016	700	630	350	500	315	100	50	M16	376

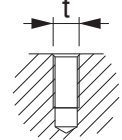

2650

- Material: Guss
- Spannen Werkstücke auf 4 Flächen möglich
- kompatibel mit Standard-Spannelementen
- auf allen Flächen M12-M16, Gewindeabstand 50 ± 0,02

2650

- Material : Casting
- Workpiece can be applied on four faces.
- It is in compliance with Standard Coupling Equipment.
- M12 - M16 thread gap on it's surface is 50 ± 0.02.

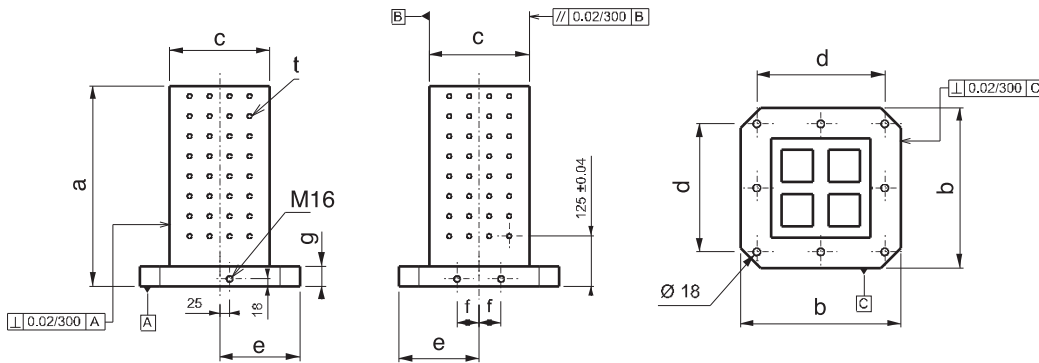

Referenz-Nr. Order No.	a	b	c	d	e	f	g		
2660-40025012	500	400	250	320	200	55	50	M12	170
2660-50030012	600	500	300	400	250	75	50	M12	230
2660-63035012	700	630	350	500	315	100	50	M12	380
2660-40025016	500	400	250	320	200	55	50	M16	168
2660-50030016	600	500	300	400	250	75	50	M16	228
2660-63035016	700	630	350	500	315	100	50	M16	376

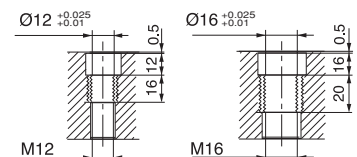



2660

- Material: Guss
- Spannen Werkstücke auf 4 Flächen möglich
- kompatibel mit Standard-Spannelementen
- auf allen Flächen M12-M16, Gewindeabstand 50 ± 0,02
- Auf Anfrage mit gehärteten Stahlbuchsen erhältlich

2660

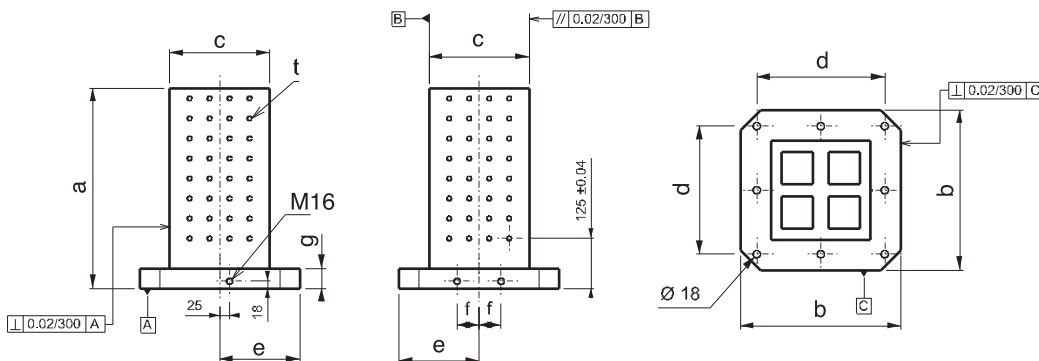
- Material : Casting
- Workpiece can be applied on four faces.
- It is in compliance with Standard Coupling Equipment.
- M12 - M16 thread gap on it's surface is 50 ± 0.02.
- It's steel bush threads are hardened.



Referenz-Nr. Order No.	a	b	c	d	e	f	g	
2670-400150	500	400	150	320	200	55	50	175
2670-500200	600	500	200	400	250	75	50	265
2670-630250	700	630	250	500	315	100	50	484

2670

- Anwendung Fläche nach Bedarf
- Material: Guss

2670

- Application on the surface according to desired way.
- Material : Casting

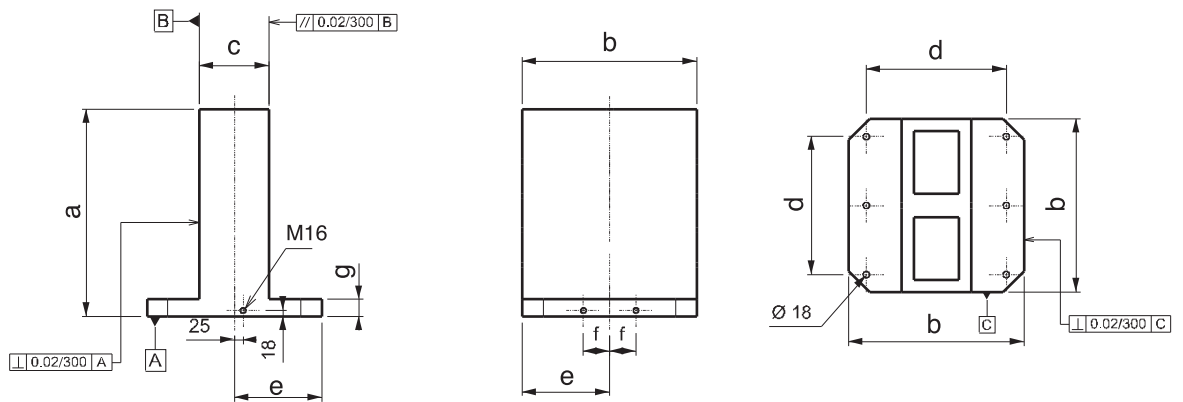

CNC Horizontaler Aufspannturm

Referenz-Nr. Order No.	a	b	c	d	e	f	g	i	k (±0.02)	J ($\frac{0.02}{0}$)	
2690-40015014	500	400	150	320	200	55	50	150	100	14	165
2690-50020014	600	500	200	400	250	75	50	150	100	14	240
2690-63025014	700	630	250	500	315	100	50	150	125	14	455
2690-40015018	500	400	150	320	200	55	50	150	100	18	152
2690-50020018	600	500	200	400	250	75	50	150	100	18	238
2690-63025018	700	630	250	500	315	100	50	150	125	18	450

Ürün Nr. 2690 Yatay İşleme Kulesi (Dikdörtgen) T-Kanallı

- Spannen Werkstücke auf beiden Flächen möglich
- kompatibel mit Standard-Spannelementen
- T-Nuten 14 mm - 18 mm DIN 650
- Material: Guss

Product Nr. 2690 Horizontal Processing Cube (Rectangular) with T-Slot

- Workpiece can be applied on four faces.
- It is in compliance with Standard Coupling Equipment.
- T-Slot is in the standard of 14mm - 18mm DIN 650.
- Material : Casting

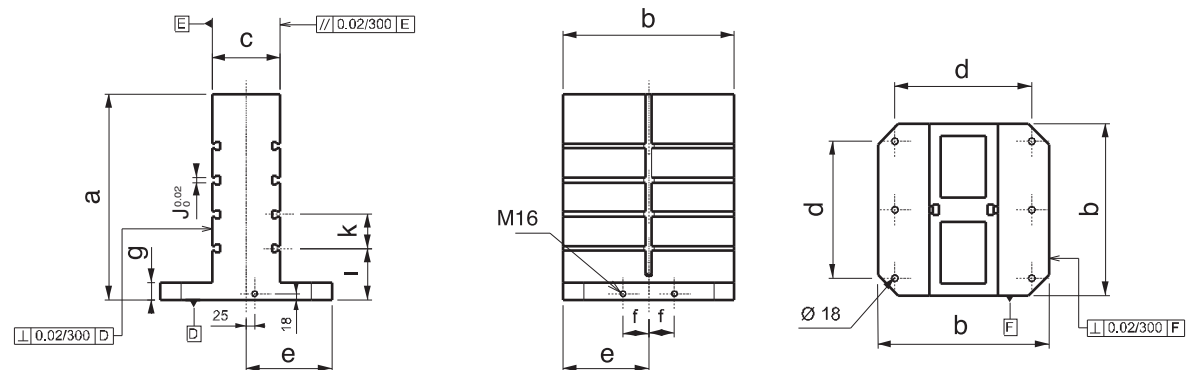

Referenz-Nr. Order No.	a	b	c	d	e	f	g		 (kg)
2710-40015012	500	400	150	320	200	55	50	M12	170
2710-50020012	600	500	200	400	250	75	50	M12	250
2710-63025012	700	630	250	500	315	100	50	M12	475
2710-40015016	500	400	150	320	200	55	50	M16	164
2710-50020016	600	500	200	400	250	75	50	M16	248
2710-63025016	700	630	250	500	315	100	50	M16	470

2710

- Material: Guss
- Spannen Werkstücke auf beiden Flächen möglich
- kompatibel mit Standard-Spannelementen
- auf beiden Flächen M12-M16, Gewindeabstand $50 \pm 0,02$

2710

- Material : Casting
- Workpiece can be applied on two faces.
- It is in compliance with Standard Coupling Equipment.
- M12 - M16 thread gap on it's surface is 50 ± 0.02 .

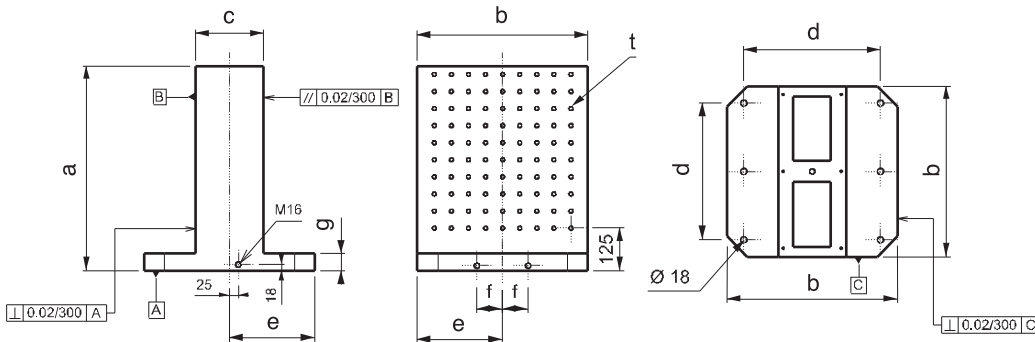
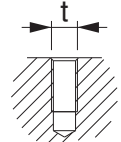
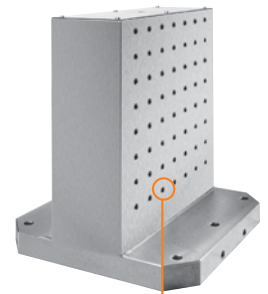

CNC Horizontaler Aufspannturm

CNC Horizontal Processing Cube

Referenz-Nr. Order No.	a	b	c	d	e	f	g		 (kg)
2720-40015012	500	400	150	320	200	55	50	M12	170
2720-50020012	600	500	200	400	250	75	50	M12	250
2720-63025012	700	630	250	500	315	100	50	M12	475
2720-40015016	500	400	150	320	200	55	50	M16	164
2720-50020016	600	500	200	400	250	75	50	M16	248
2720-63025016	700	630	250	500	315	100	50	M16	470

2720

- Material: Guss
- Spannen Werkstücke auf beiden Flächen möglich
- kompatibel mit Standard-Spannelementen
- auf beiden Flächen M12-M16, Gewindeabstand $50 \pm 0,02$
- Auf Anfrage mit gehärteten Stahlbuchsen erhältlich

2720

- Material : Casting
- Workpiece can be applied on two faces.
- It is in compliance with Standard Coupling Equipment.
- M12 - M16 thread gap on it's surface is 50 ± 0.02 .
- It's steel bush threads are hardened.

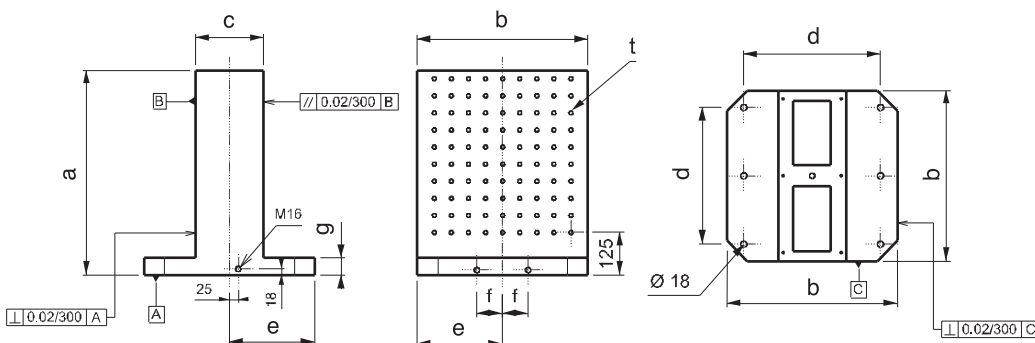
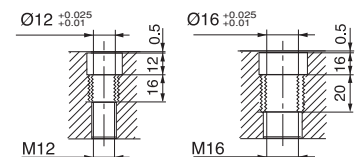
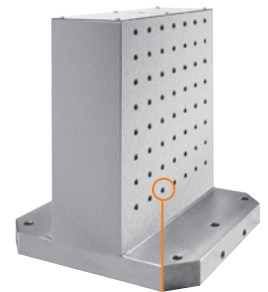

Referenz-Nr. Order No.	m	a	b	c	sw	e	g	h	Tragkraft Lifting Force of one Ringbolt Kgf	 (g)
2730-016	M16	39	85	35	30	30	45	10	660	370
2730-020	M20	39	85	35	30	30	45	10	1000	390

2730

- Spannmaß M16-M20
- Schwarz beschichtet

2730

- Coupling Measurement: M16 - M20
- Black Coating

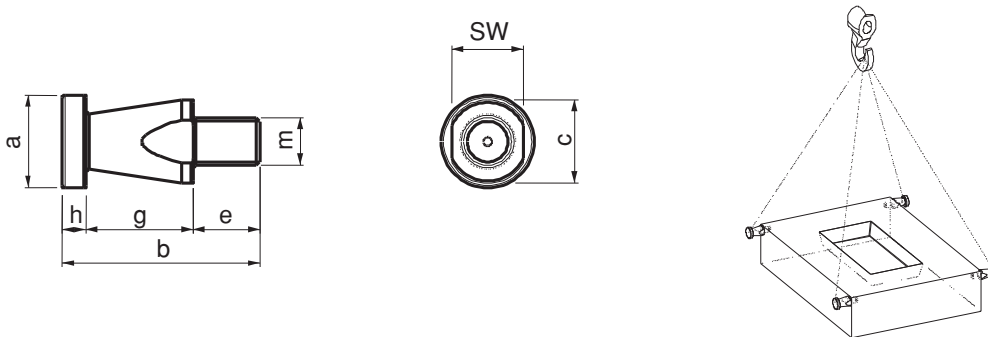

Referenz-Nr. Order No.	a	b	c	d	e	f	g	h	i	n	s	Tragkraft Lifting Force of one Ringbolt Kgf	 (g)
2750-044	44	108	32	27	15	22	23	11	37	11	22	400	525

2750

- Spannmaß DIN 912 M10x35 Inbus
- Schwarz beschichtet

2750

- Coupling Bolt Measurement: DIN 912 M10x35 Inbus
- Black Coating

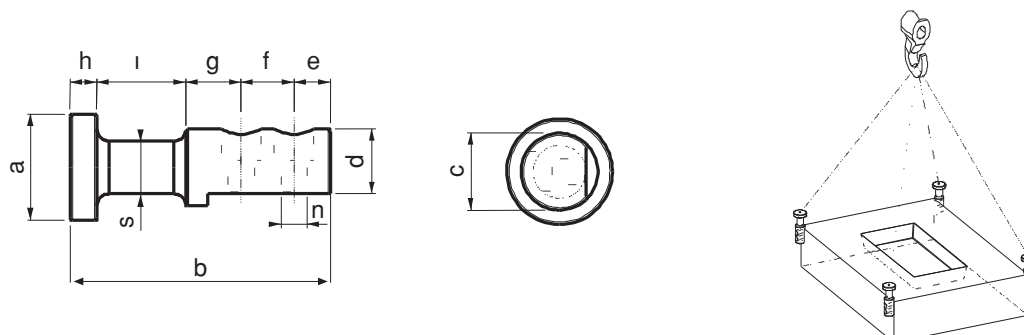

Referenz-Nr. Order No.	inch	Tonhöhe pitch	L	b	h	n t7	c	k	j	e	m	s	Ø min	(g)
2770-0612	6" inch	1.5x60	72	32	32	12	5	15	20	11	22	10	6.5	1460
2770-0814	8" inch	1.5x60	98	37	37	14	5	24	25	13	22	14	8.5	2785
2770-1016	10" inch	1.5x60	110	42	42	16	5	30	30	13	29	14	10	4060
2770-1218	12" inch	1.5x60	130	50	52	18	5	39	30	15	32	17	12	6510
2770-1221	12" inch	1.5x60	130	50	52	21	5	39	30	17	32	19	12	6575
2775-0612	6" inch	1.5x60	72	28	37	12	5	15	20	11	17	10	6.5	1415
2775-0814	8" inch	1.5x60	95	35	67	14	5	24	25	13	19	14	8.5	4465
2775-1016	10" inch	1.5x60	110	38	77	16	5	30	30	13	19	14	10	6850
2775-1218	12" inch	1.5x60	130	48	77	18	5	39	30	15	23	17	12	10075
2775-1221	12" inch	1.5x60	130	48	77	21	5	39	30	17	23	19	12	9600



2770 - 2775

- für 6" - 8" - 10" - 12" Spannfutter

2770 - 2775

- For chucks of 6" - 8" - 10" and 12"

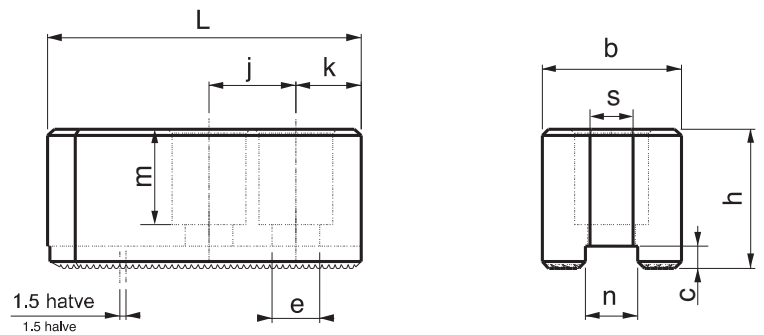

Doppelter T-Nutenstein

CNC Soft Podous T-Nut

Referenz-Nr. Order No.	inch	L	h	n T6	n1	h1	d	j	(g)
2790-0610	6" inch	38	18.5	12	18	7.5	M10	20	55
2790-0812	8" inch	45	21.5	14	21	8.5	M12	25	85
2790-1012	10" inch	52	21.5	16	22	8.5	M12	30	115
2790-1214	12" inch	55	33.5	18	26.5	13.5	M14	30	225
2790-1216	12" inch	55	27	21	29	13.5	M16	30	210



2790

- für 6" - 8" - 10" - 12" Spannfutter
- Gehärtet
- Schwarz beschichtet

2790

- For chucks of 6" - 8" - 10" and 12"
- Hardened
- Black Coating

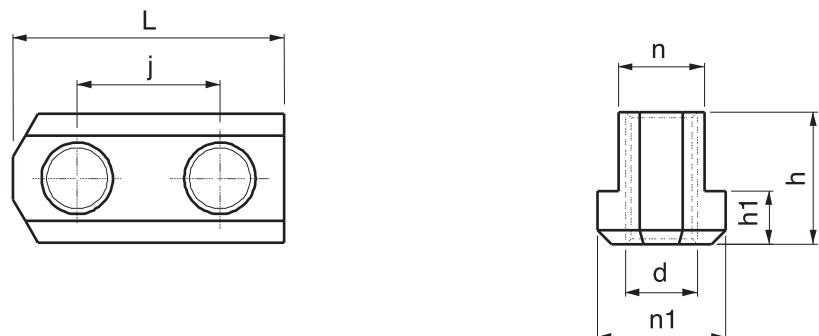

Spezial-Projektanwendungen

Special Project Based Applications



Hinweis: Um alle Arten von Werkstücken zu verbinden, werden mechanische, pneumatische und hydraulische Vorrichtungsanwendungen durchgeführt.
Note : To connect all kinds of workpiece, mechanical, pneumatic and hydraulic fixture applications are made.

Spezial-projektanwendungen

Special Project Based Applications

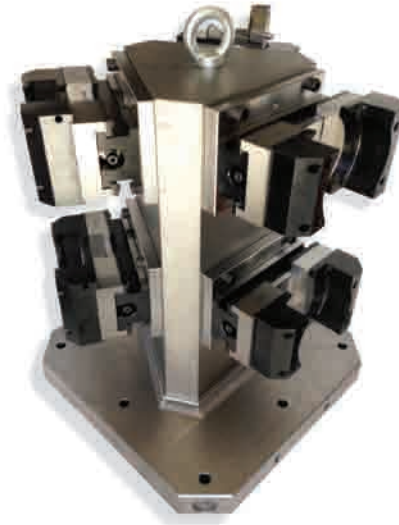
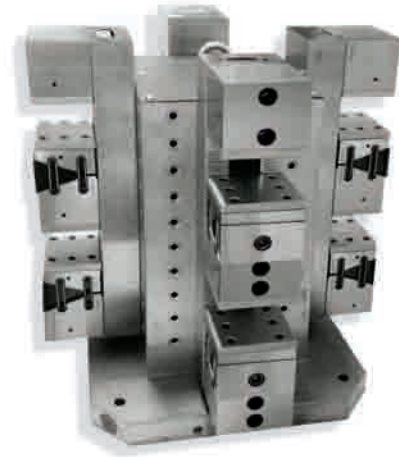
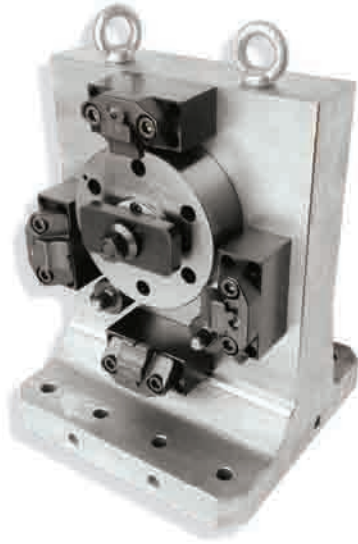

Hinweis: Um alle Arten von Werkstücken zu verbinden, werden mechanische, pneumatische und hydraulische Vorrichtungsanwendungen durchgeführt.
Note : To connect all kinds of workpiece, mechanical, pneumatic and hydraulic fixture applications are made.

Erstellen Sie eine spezielle Auftragsvorlage / Create A Special Order Template

1330

Spanneisen mit Stützgewinde
Straight Clamp with Support Hole

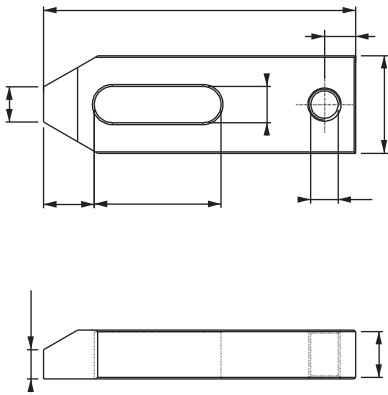

1350

Spanneisen gerade
Straight Clamp

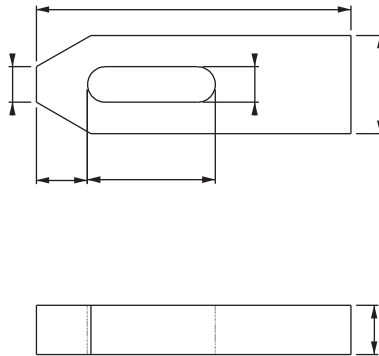

1590

Schraube für T-Nut
T-Slot Bolt

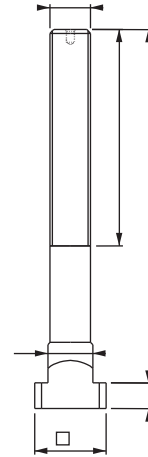

1670

Schraube mit Schlüsselweite für T-Nut
Wrench Mouth Stud

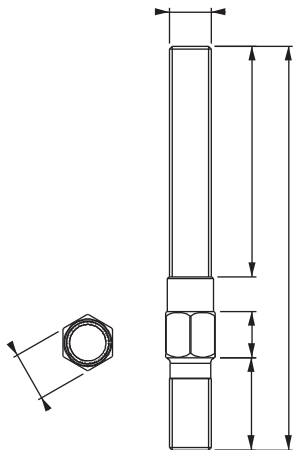

1690

Stiftschraube
Straight Stud

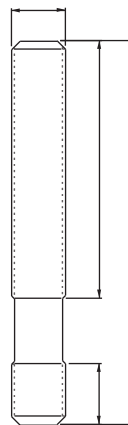

1750

Mutter für T-Nuten
"T" Clamp

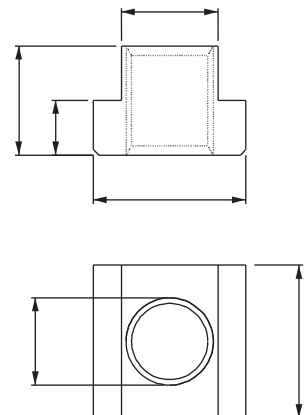

1790

Sechskantmutter
Hexagon Nut

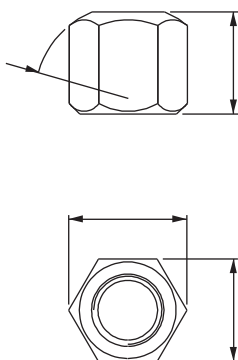

1810

Sechskantmutter mit Bund
Nut with Washer

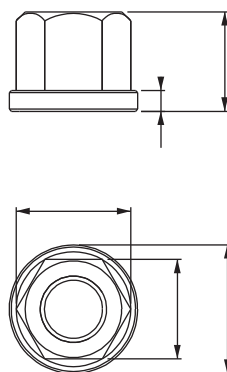

1870

Scheibe
Washer

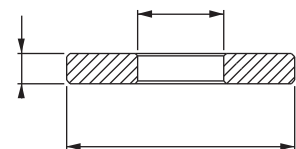

Anwendung Richtig-Falsch

Right - Wrong Use

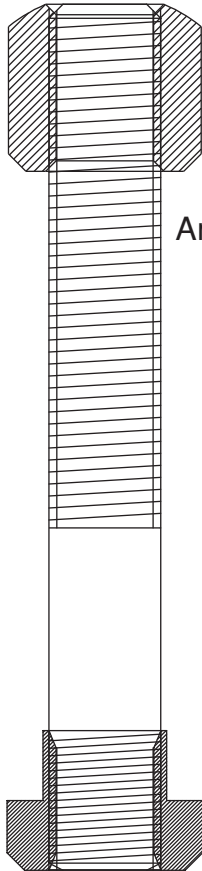

Seien Sie sicher, das bei modularen Anwendungen die Stiftschraube komplett in den Nutzenstein eingeschraubt ist.

Make sure that in the use of modular Hexagon Nut and T-Nut is screwed fully into the Stud.

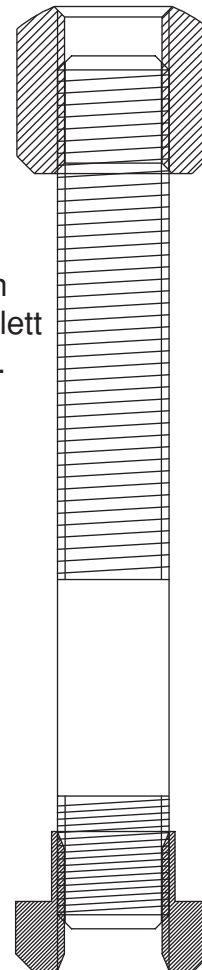

Anwendung Richtig-Falsch

Right - Wrong Use

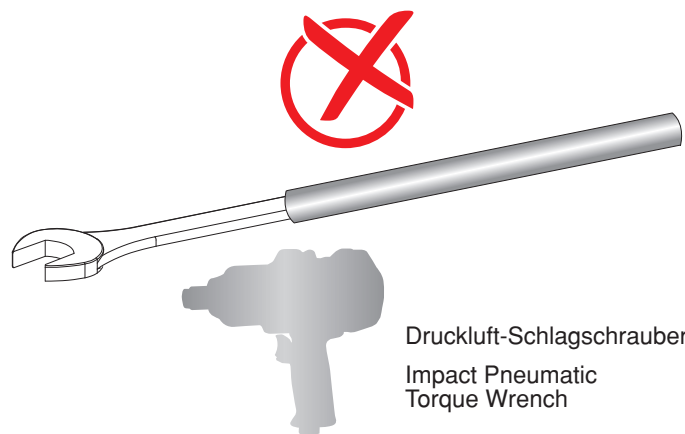
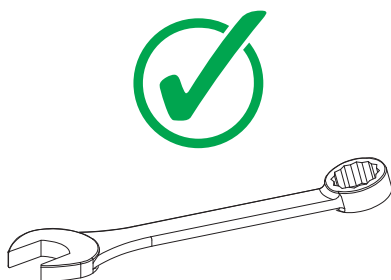
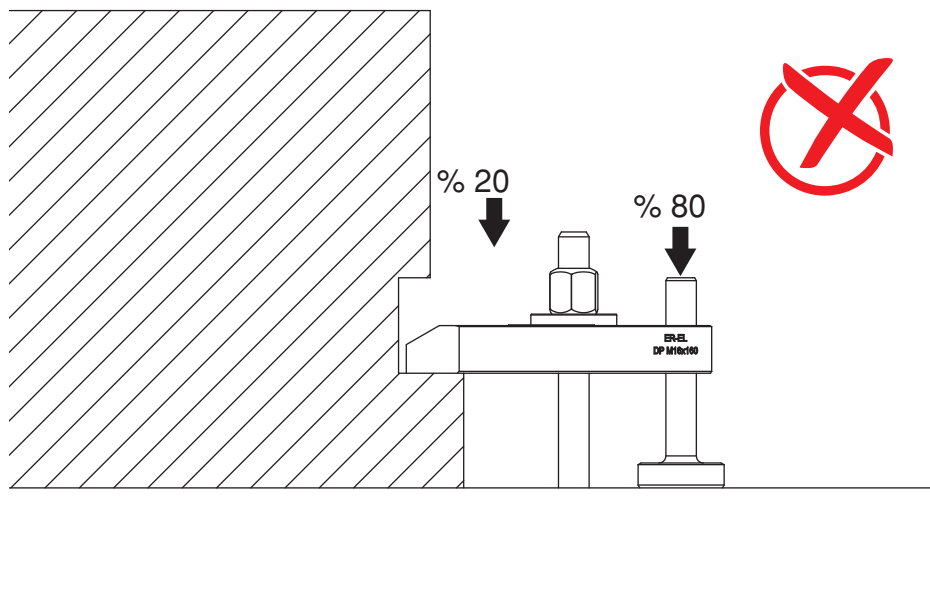
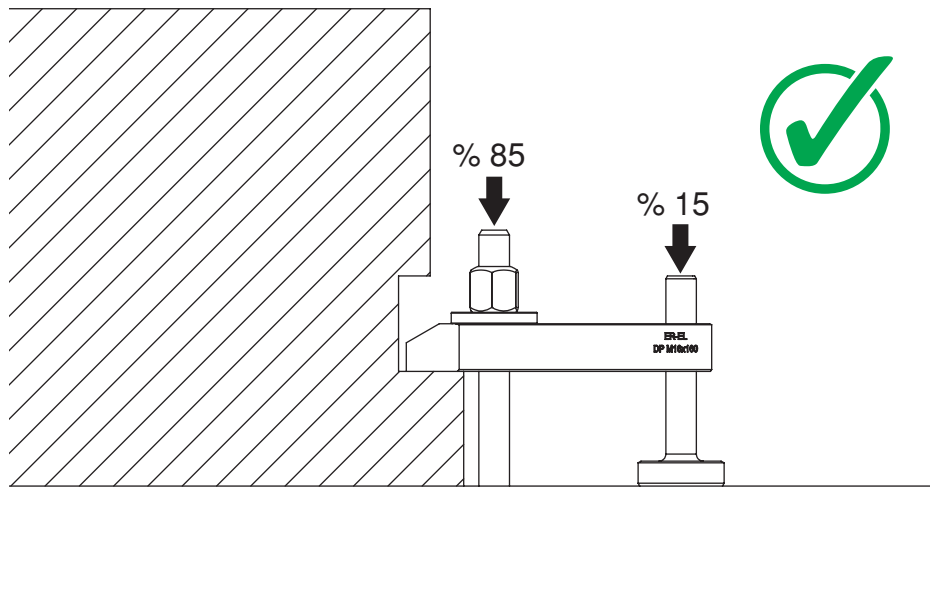



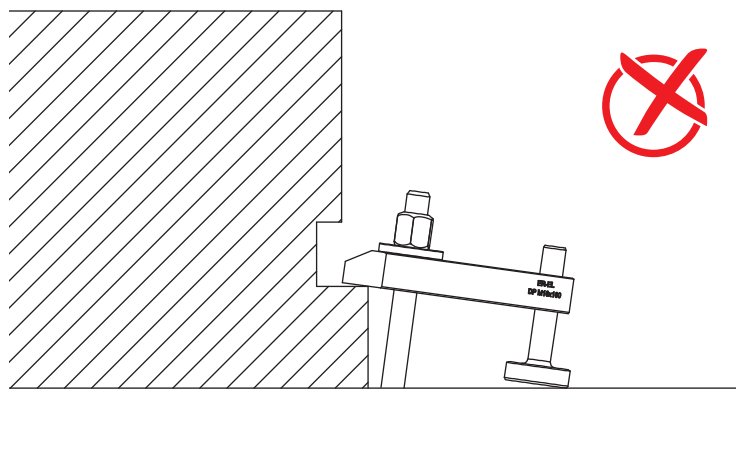
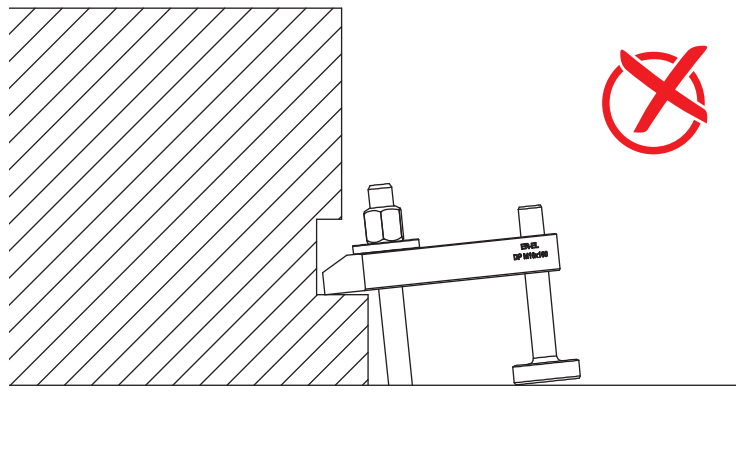

Druckluft-Schlagschrauber
Impact Pneumatic
Torque Wrench

Anwendung Richtig-Falsch



Right - Wrong Use

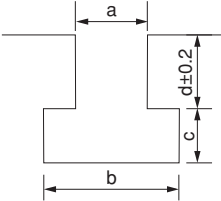

Datum / Date:...../...../.....

Firmenname : Company Name :			
Telefonnummer & Adresse : Contact tel & address :			
Kontaktperson : Authorized Person :			
Presskraft / Press tonnage :			
Marke/Modell/Type Marke/Modell/Type		Werkzeug-Referenznr. Mold Reference No:	
Maße des Pressentisches : Press Plate Measurements :	Oben Top X:.....	Y:.....	Unten Bottom X:..... Y:.....
Pres Tork Mesafesi :			
Sind U-Kanäle in der Presse vorhanden? Is there U channel in Press?	Ja Yes	Nein No	Maße its measure
T-Nutform der Presse T-channel shape of Press	Unten Bottom	Oben Top	
			
Maße der T-Nut : T-channel measure of Press :			
	Untere Platte Top Table:	A:..... B:..... C:..... D:.....	
	Obere Platte Bottom Table:	A:..... B:..... C:..... D:.....	
Nutabstand : Channel Center Distance :			
Arbeitstemperatur des Werkzeugs / Mold Working Heat :		Handhabung des Werkzeugs / Mold Transportation Shape :	
Informationen zum hydraulischen Spannelement / Hydraulic Clamp Information			
Auswahl des Spannelementes Selection of clamp :	Höhe der Werkzeugplatte Plate Thickness	Unten Bottom H:.....	Oben Top H:.....
Informationen zum hydraulischen Werkzeugheber Die Lifter Hydraulic Information			
Werkzeuggewicht Mold Weight	Werkzeugmaße Mold Size:	X:.....	Y:..... Z:.....
Informationen zum Werkzeugschiebearm Die Arm Informations:			
Das zu tragende Gewicht Load Capacity :	Schweres Modell Heavy Model		Leichtes Modell Light Model
			
Mit Unterstützer? Supported?	Ja Yes	Nein No	
Modell RS : Modell RS :	L= Werkzeuglänge Mold Length	H= Bodenhöhe Ground Height	W= Werkzeuggewicht Mold Weight
Wird ein komplettes System benötigt? Company wants whole system setup?	Ja Yes	Nein No	
Dieser Abschnitt wird seitens ER-EL ausgefüllt This part will be filled in by ER-EL			
Für dieses System geeignete Modelle / Codes der Elemente: Model / code information of the equipment to be used in the system:			

Datum / Date:...../...../.....

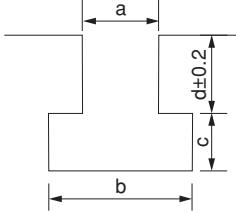
Firmenname : <i>Company Name</i> :			
Telefonnummer & Adresse : <i>Contact tel & address</i> :			
Kontaktperson : <i>Authorized Person</i> :			
Einspritzmenge / <i>Injection tonnage</i> :			
Marke/Modell/Type <i>Marke/Modell/Type</i>		Werkzeug-Referenznr. <i>Mold Reference No:</i>	
Informationen zur Injektion <i>Injection working information:</i>			
Abmessungen der Maschinenplatte <i>Injection Plate Measurements</i>		Links <i>Left</i>	Rechts <i>Right</i>
X:.....	Y:.....	X:.....	Y:.....
Entfernung des Einspritzmomentes <i>Injection Torque Distance:</i>			
Auf der Platte *Zahn* <i>*THREAD* in Machine</i>		Ja <i>Yes</i>	Nein <i>No</i>
Wenn ja, Abstand zum Mittelpunkt: <i>If there is thread in the machine, center interval :</i>		Maße <i>its measure</i>	
T-Nutform der Maschine <i>T-channel shape of Injection</i>		Links <i>Left</i>	Rechts <i>Right</i>
			
Maße der T-Nut <i>T-channel measure of Injection:</i>			
Linke Platte <i>Left Table:</i>		A:.....	B:.....
Rechte Platte <i>Right Table:</i>		A:.....	B:.....
		C:.....	D:.....
		C:.....	D:.....
Nutabstand <i>Center interval of channel :</i>			
Arbeitstemperatur <i>Working Heat :</i>			
Informationen zum hydraulischen Spannelement <i>Hydraulic Clamp Informations:</i>			
Werkzeuggewicht <i>Weight of Mold :</i>		Links <i>Left</i>	Rechts <i>Right</i>
Höhe der Werkzeugplatte <i>Mold Plate Thickness:</i>		H:....	H:....
Wird ein komplettes System benötigt? <i>Company wants whole system setup?</i>		Ja <i>Yes</i>	Nein <i>No</i>
Dieser Abschnitt wird seitens ER-EL ausgefüllt <i>This part will be filled in by ER-EL</i>			
Für dieses System geeignete Modelle / Codes der Elemente: <i>Model / code information of the equipment to be used in the system:</i>			



“Wir produzieren Qualität”

“We produce quality”

Wir exportieren in mehr als 24 Länder...
Export to more than 24 countries...



Standard Produkte
Standart Products



5-Achs Basismodul
5-Axis Clamping
Block System



Werkzeug-Schnellwechselsystem
Quick Die Change System



ER-EL Zero Clamp
ER-EL Zero Point Clamping System



Hydraulik-Komponenten
Hydraulic Components



Spezial-
-Projektanwendungen
Special Project
Based Applications



ER-EL

ER-EL MAKİNA YEDEK PARÇA İML. SAN. ve TİC. LTD. ŞTİ.
Çerkeşli OSB Mah. İMES 3 Blv. No:14 Dilovası - Kocaeli
Tel.: (+90) 262 502 11 60 Pbx Fax: (+90) 262 502 11 59
info@er-el.com.tr www.er-el.com.tr

twitter.com/ERELkalip

facebook.com/erelmakina
facebook.com/erelmachine

instagram.com/erelkalip

linkedin.com/in/er-el-makina

plus.google.com/u/0/+ER-ELMAKINA

youtube.com/erelkalip