

Dış Ölçüler Outline Dimensions	<p>D 8 Serisi / Serial</p> 
Pleyt için işlem ölçüsü (U-Kanal) Processing Size for Plate (U-slot)	

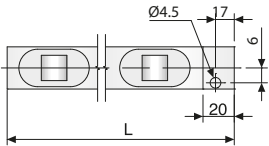
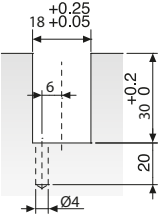
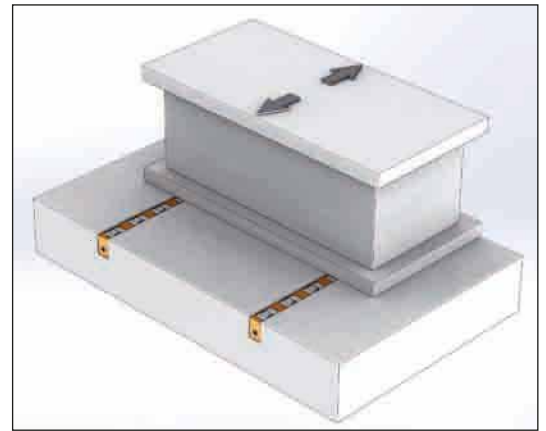

Model DL Hareket Yönü
Model DL Movement Direction

Referans Nr.	L	D 8				Hid. Silindir Hyd. cylinder	
		DL18		DB18		Piston	Kapasite Capacity kg
		Rulo Roller (DL)	Kapasite Capacity kg	Misket Ball (DB)	Kapasite Capacity kg		
1020-0200	200	3	300	5	250	2	560
1020-0300	300	5	500	7	350		
1020-0400	400	6	560	10	500		
1020-0500	500	8	800	12	600	3	840
1020-0600	600	9	840	15	750		
1020-0700	700	11	840	17	840		
1020-0800	800	12	1120	20	1000	4	1120
1020-0900	900	14	1120	22	1100		
1020-1000	1000	15	1250	25	1250		

Ürün Nr. 1020 Hidrolik Kalıp Kaldırma Model DL-DB

Product Nr. 1020 Die Lifter Hydraulic Model DL-DB

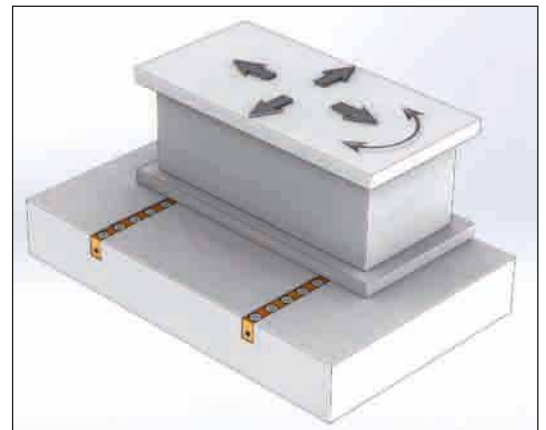

Model DB Hareket Yönü
Model DB Movement Direction

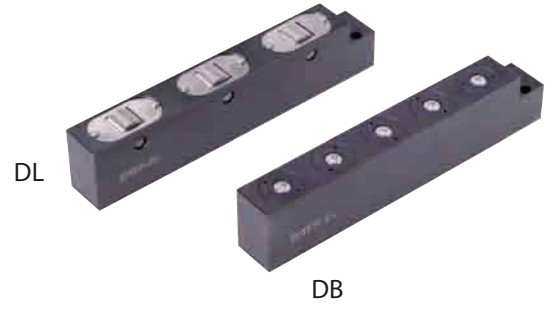
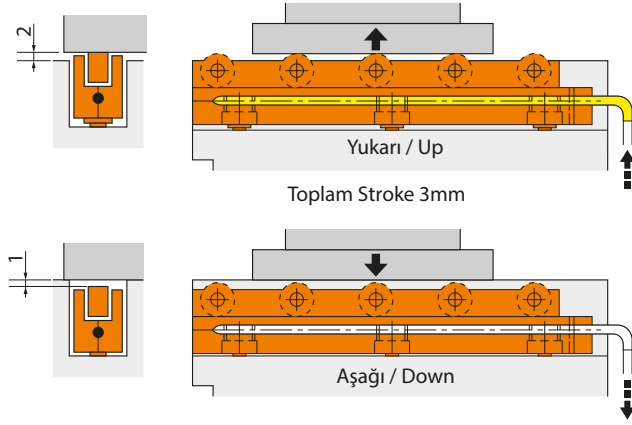

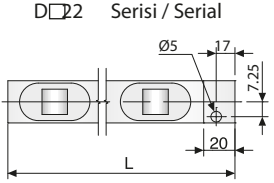
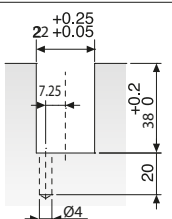
Dış Ölçüler Outline Dimensions	 <p>D22 Serisi / Serial</p>
Pleyt için işlem ölçüsü (U-Kanal) Processing Size for Plate (U-slot)	

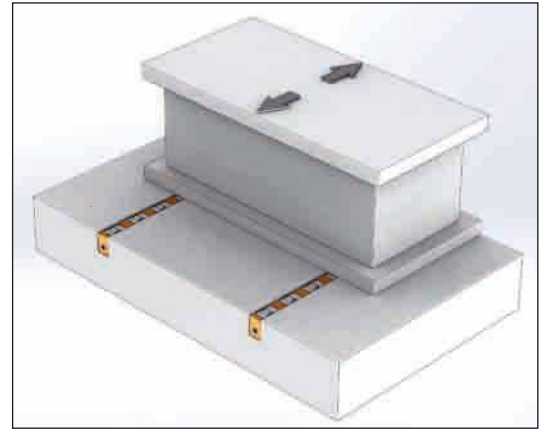

Model DL Hareket Yönü
Model DL Movement Direction

Referans Nr.	L	D22				Hid. Silindir Hyd. cylinder	
		DL22		DB22		Piston	Kapasite Capacity kg
		Rulo Roller (DL)	Kapasite Capacity kg	Misket Ball (DB)	Kapasite Capacity kg		
1020-0200	200	3	480	5	370	2	1000
1020-0300	300	5	800	7	518		
1020-0400	400	6	960	10	740		
1020-0500	500	8	1280	12	888	3	1500
1020-0600	600	9	1400	15	1110		
1020-0700	700	11	1500	17	1250		
1020-0800	800	12	1920	20	1480		
1020-0900	900	14	2000	22	1628	4	2000
1020-1000	1000	15	2000	25	1850		

Ürün Nr. 1020 Hidrolik Kalıp Kaldırma Model DL-DB

Product Nr. 1020 Die Lifter Hydraulic Model DL-DB

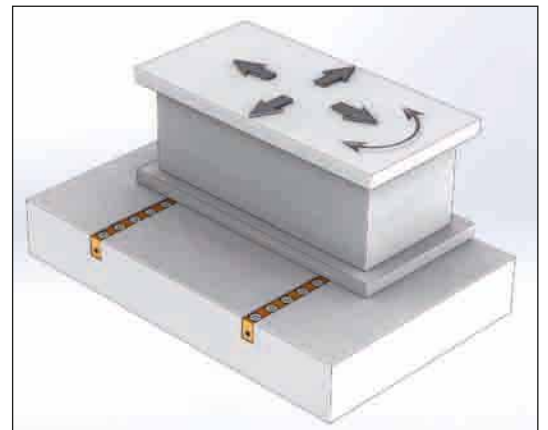

Model DB Hareket Yönü
Model DB Movement Direction

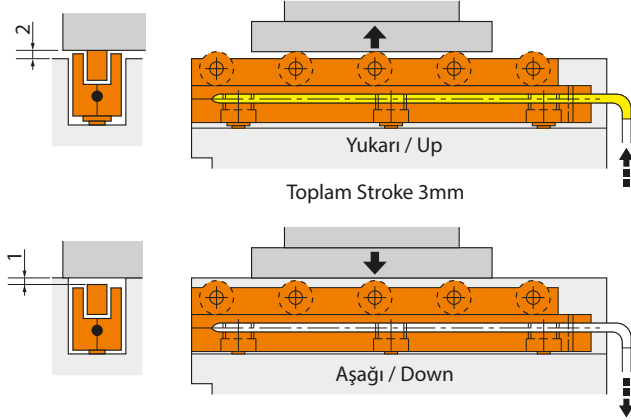

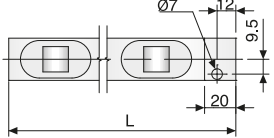
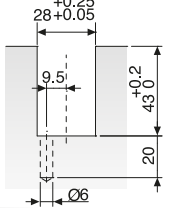
D \square 28 Serisi / Serial	
Dış Ölçüler Outline Dimensions	
Pleyt için işlem ölçüsü (U-Kanal) Processing Size for Plate (U-slot)	

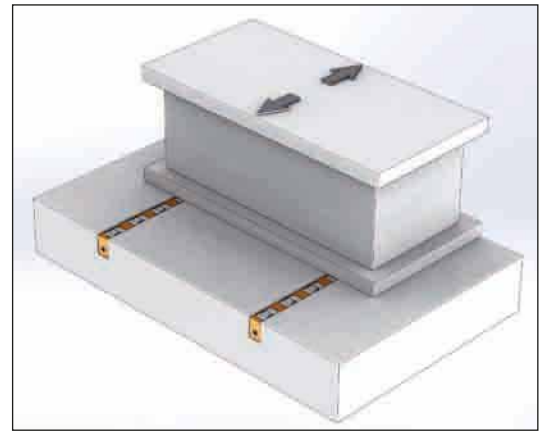

Model DL Hareket Yönü
Model DL Movement Direction

Referans Nr.	L	D \square 28				Hid. Silindir Hyd. cylinder	
		DL28		DB28		Piston	Kapasite Capacity kg
		Rulo Roller (DL)	Kapasite Capacity kg	Misket Ball (DB)	Kapasite Capacity kg		
1020-0200	200	3	750	5	475	2	1260
1020-0300	300	5	1250	7	665		
1020-0400	400	6	1260	10	950	3	1890
1020-0500	500	8	1890	12	1140		
1020-0600	600	9	1890	15	1425		
1020-0700	700	11	1890	17	1615	4	2520
1020-0800	800	12	2520	20	1900		
1020-0900	900	14	2520	22	2090	5	3150
1020-1000	1000	15	3150	25	2375		
1020-1100	1100	16	3150	27	2565		
1020-1200	1200	17	3150	30	2850	6	3780
1020-1300	1300	18	3780	32	3040		
1020-1400	1400	19	3780	35	3325	7	4410
1020-1500	1500	20	3780	37	3515		
1020-1600	1600	22	4410	40	3800		
1020-1700	1700	24	4410	42	3990	8	5040
1020-1800	1800	25	4410	45	4275		
1020-1900	1900	27	5040	47	4465		

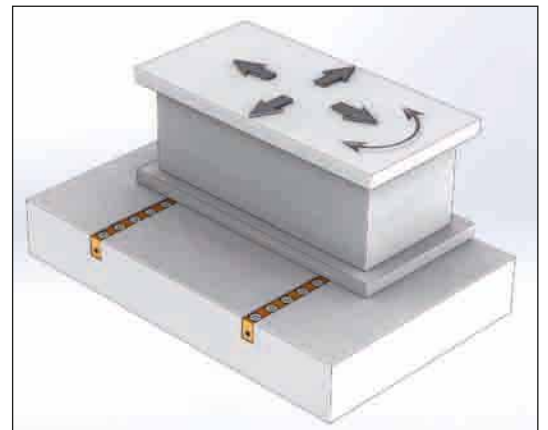

Model DB Hareket Yönü
Model DB Movement Direction

Ürün Nr. 1020 Hidrolik Kalıp Kaldırma Model DL-DB

Product Nr. 1020 Die Lifter Hydraulic Model DL-DB

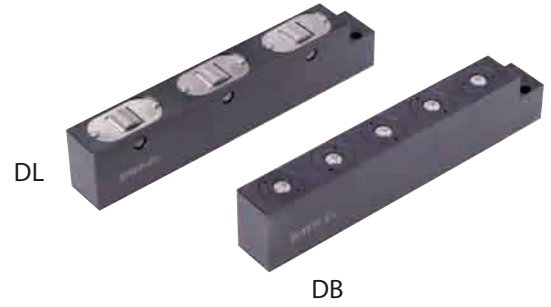
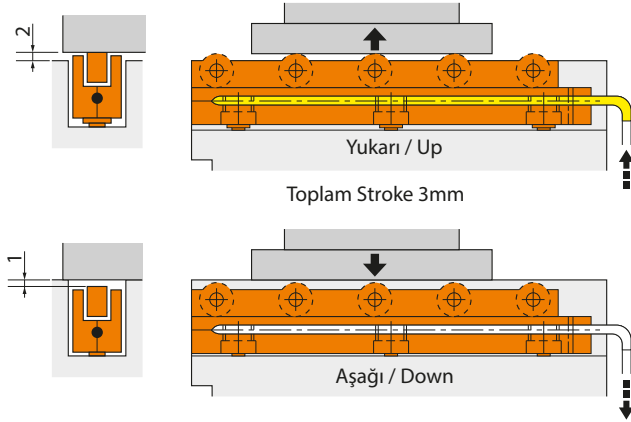

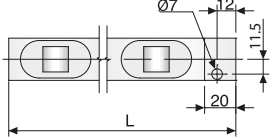
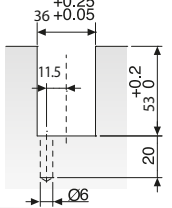
Dış Ölçüler Outline Dimensions		DDB6 Serisi / Serial	
			
Pleyt için işlem ölçüsü (U-Kanal) Processing Size for Plate (U-slot)			

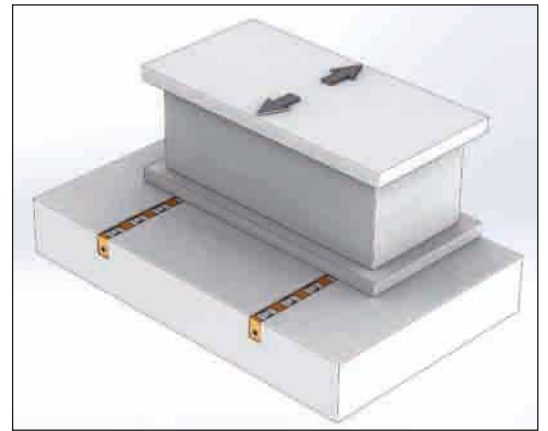

Model DL Hareket Yönü
Model DL Movement Direction

Referans Nr.	L	DDB6				Hid. Silindir Hyd. cylinder	
		DL36		DB36		Piston	Kapasite Capacity kg
		Rulo Roller (DL)	Kapasite Capacity kg	Misket Ball (DB)	Kapasite Capacity kg		
1020-0200	200	3	1050	5	600	2	1700
1020-0300	300	5	1750	7	840		
1020-0400	400	6	1700	10	1200		
1020-0500	500	8	2600	12	1440	3	2600
1020-0600	600	9	2600	15	1800		
1020-0700	700	11	2600	17	2040		
1020-0800	800	12	2600	20	2400		
1020-0900	900	14	3500	22	2640	4	3500
1020-1000	1000	15	3500	25	3000		
1020-1100	1100	16	3500	27	3240		
1020-1200	1200	17	4400	30	3600	5	4400
1020-1300	1300	18	4400	32	3840		
1020-1400	1400	19	4400	35	4200		
1020-1500	1500	20	4400	37	4400		
1020-1600	1600	22	5300	40	4800	6	5300
1020-1700	1700	24	5300	42	5040		
1020-1800	1800	25	5300	45	5300		
1020-1900	1900	27	5300	47	5300		

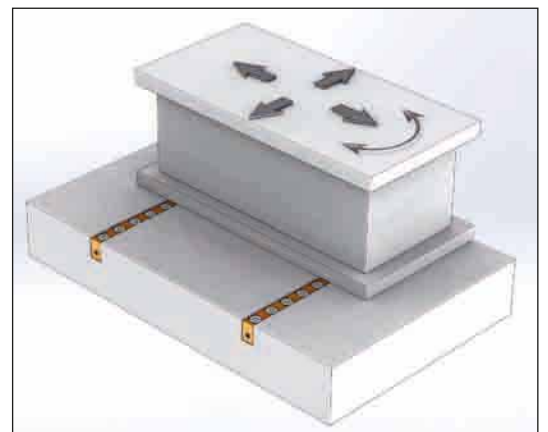

Model DB Hareket Yönü
Model DB Movement Direction

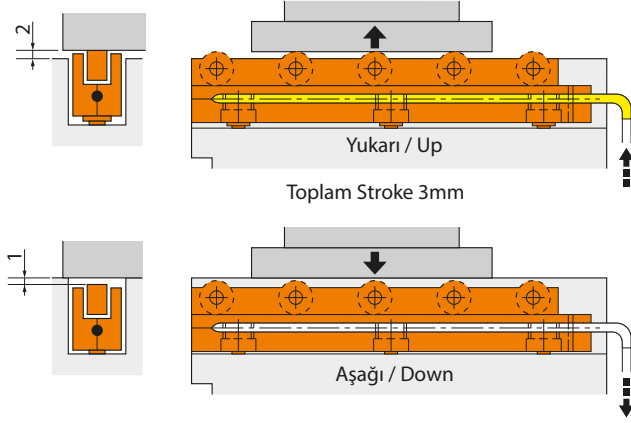

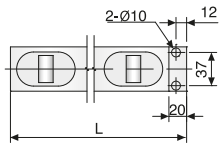
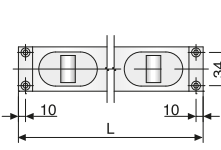
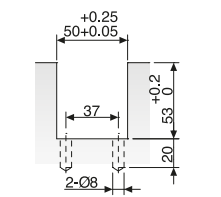
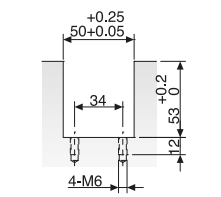
Dış Ölçüler Outline Dimensions	D \square 50 Serisi / Serial DL50-2100'den önce	D \square 50 Serisi / Serial DL50-2100'den sonra
		
Pleyt için işlem ölçüsü (U-Kanal) Processing Size for Plate (U-slot)		

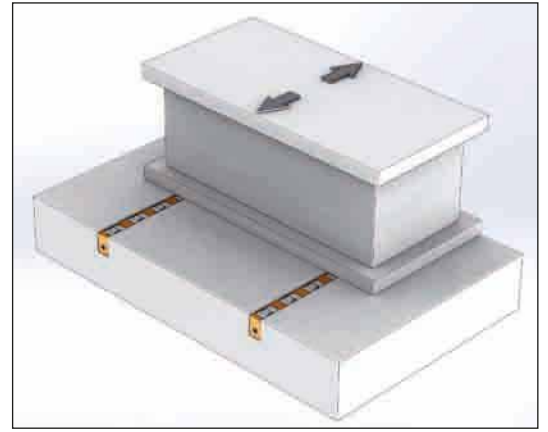

Model DL Hareket Yönü
Model DL Movement Direction

Referans Nr.	L	D \square 50				Hid. Silindir Hyd. cylinder	
		DL50		DB50		Piston	Kapasite Capacity kg
		Rulo Roller (DL)	Kapasite Capacity kg	Misket Ball (DB)	Kapasite Capacity kg		
1020-0200	200	2	1000	4	640	2	2200
1020-0300	300	3	1500	6	960		
1020-0400	400	4	2000	9	1440		
1020-0500	500	5	2500	11	1760		
1020-0600	600	6	3000	13	2080		
1020-0700	700	7	3300	16	2560		
1020-0800	800	8	3300	18	2880		
1020-0900	900	9	4400	20	3200		
1020-1000	1000	10	4400	23	3680		
1020-1100	1100	11	4400	25	4000		
1020-1200	1200	12	5500	27	4320		
1020-1300	1300	13	5500	29	4640		
1020-1400	1400	14	5500	31	4960		
1020-1500	1500	15	5500	33	5280		
1020-1600	1600	16	6500	35	5600		
1020-1700	1700	17	6500	38	6080		
1020-1800	1800	18	6500	40	6400		
1020-1900	1900	19	6500	42	6720		
1020-2000	2000	20	7700	44	7040		
1020-2100	2100	21	7700	46	7360		
1020-2200	2200	22	7700	48	7680		
1020-2300	2300	23	7700	50	7700		
1020-2400	2400	24	8800	52	8320		
1020-2500	2500	25	8800	54	8640		

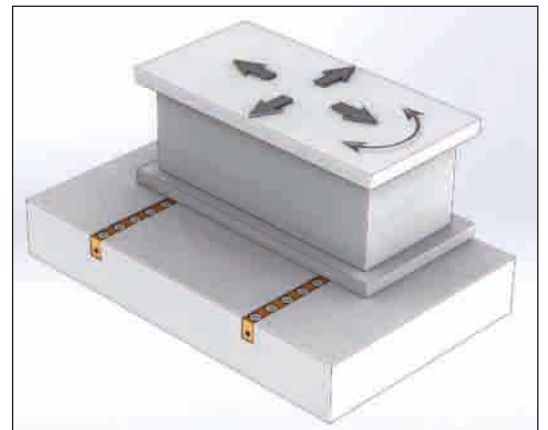

Model DB Hareket Yönü
Model DB Movement Direction

Ürün Nr. 1020 Hidrolik Kalıp Kaldırma Model DL-DB

Product Nr. 1020 Die Lifter Hydraulic Model DL-DB

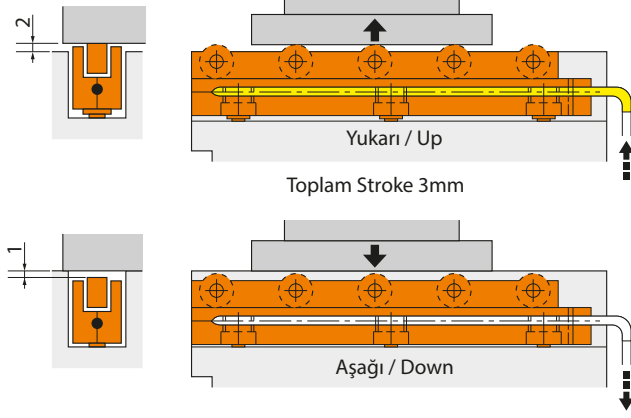

DL

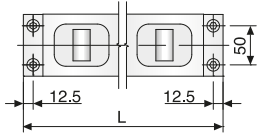
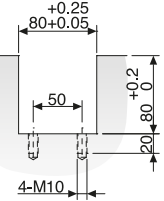

Dış Ölçüler Outline Dimensions	DL80 Serisi / Serial
	
Pleyt için işlem ölçüsü (U-Kanal) Processing Size for Plate (U-slot)	

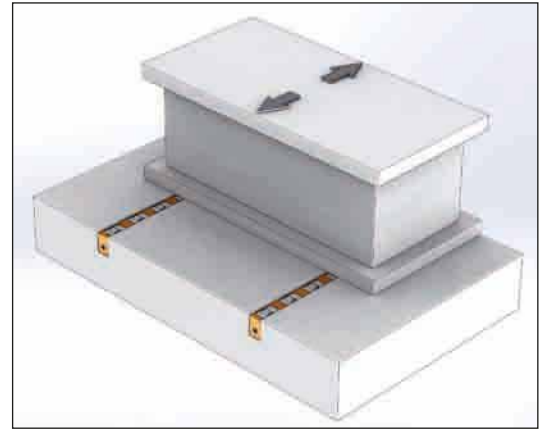

Model DL Hareket Yönü
Model DL Movement Direction

Referans Nr.	L	DL80			
		DL80		Hid. Silindir Hyd. cylinder	
		Rulo Roller (DL)	Kapasite Capacity kg	Piston	Kapasite Capacity kg
1020-0200	200	-	-	-	-
1020-0300	300	-	-	-	-
1020-0400	400	-	-	-	-
1020-0500	500	5	3250	2	5600
1020-0600	600	6	3900		
1020-0700	700	7	4550	3	8400
1020-0800	800	8	5200		
1020-0900	900	9	5850		
1020-1000	1000	10	6500	4	11200
1020-1100	1100	11	7150		
1020-1200	1200	12	7800		
1020-1300	1300	13	8450		
1020-1400	1400	14	9100	5	14000
1020-1500	1500	15	9750		
1020-1600	1600	16	10400		
1020-1700	1700	17	11050	6	16800
1020-1800	1800	18	11700		
1020-1900	1900	19	12350		
1020-2000	2000	20	13000		
1020-2100	2100	21	13650	7	19600
1020-2200	2200	22	14300		
1020-2300	2300	23	14950		
1020-2400	2400	24	15600		
1020-2500	2500	25	16250		

Ürün Nr. 1020 Hidrolik Kalıp Kaldırma Model DL-DB

Product Nr. 1020 Die Lifter Hydraulic Model DL-DB