

HIZLI KALIP DEĞİŞTİRME SİSTEMİ

QUICK MOLD CHANGE SYSTEM

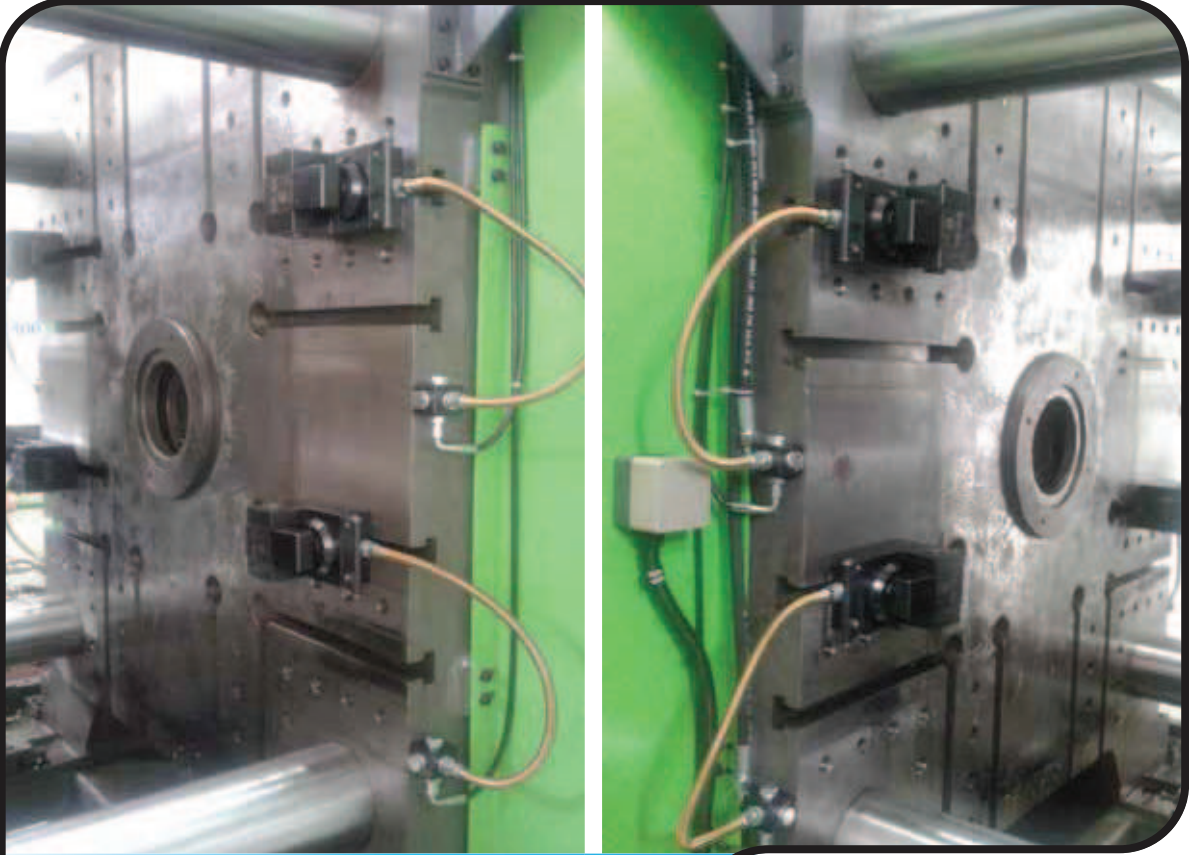

QUICK **MOLD** CHANGE SYSTEM



QUICK **DIE** CHANGE SYSTEM

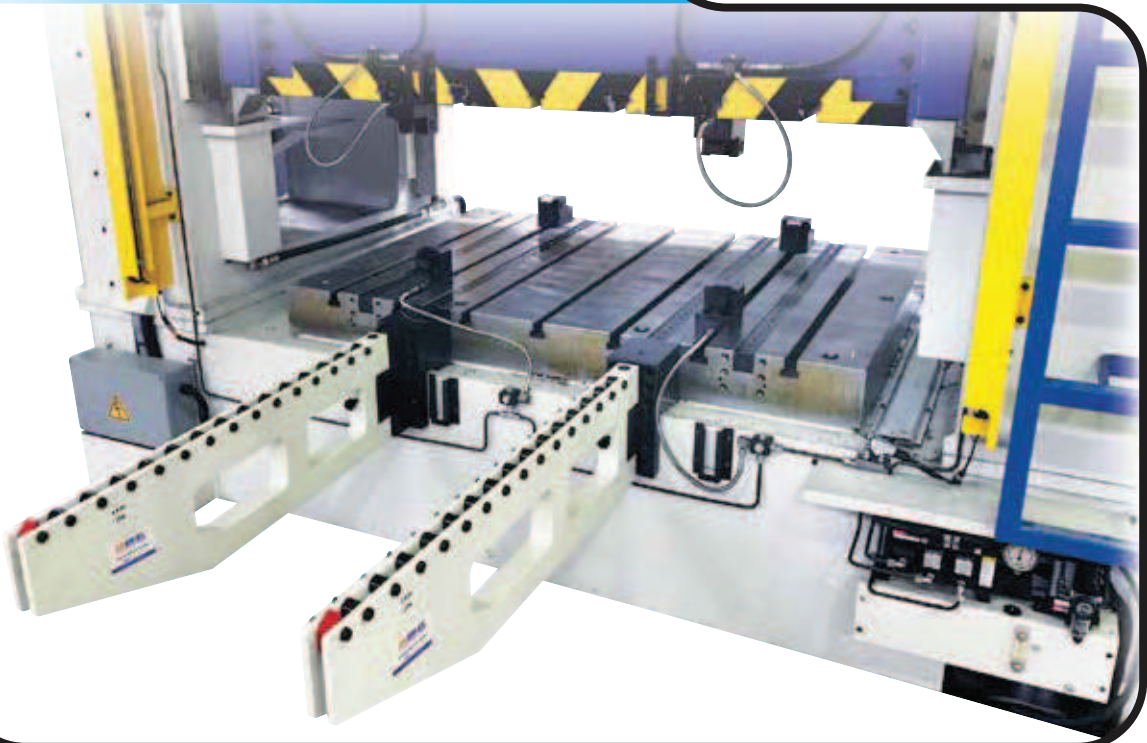

Hızlı Kalıp Değişirme Sistemi

Kalıpların hızlı değiştiği, modellerin çeşitli ve üretim adetlerinin (talep miktarlarının) az olduğu zamanlarda kalıp değişirme süresini azaltıp iş güvenliğini sağlamaktır. Bu durumda **hızlı kalıp değişirme sistemine geçmenin tam vaktidir.**

Uygulama

- Pres - hidrolik pres - enjeksiyon
- Değişik otomatik makina bağlama sistemi

Application

- Press - hydraulic press - injection
- Different automatic machine clamp system

Quick Die Change System

It's an era for making high frequency of die changing with multiple patterns and small quantity. In order to save die changing time and ensure operational safety, it is just in time to apply Quick Die Change System.

Elektronik Operasyon Kontrol Paneli
Electronic Control Operation Panel

- Makineye bağlanmak için interlock kontrol switch donanımlıdır.
- It is equipped with interlock control switch for connecting to the machine.
- Oluşabilecek herhangi bir operasyon hatasını engellemek için güvenli kontrol aygıtı ile birlikte tasarlanmıştır.
- It is designed with safety control device which prevents any operation error.

Kalıp Kaldırma / Die Lifter**Model: DL - DB - DLS - DBS**

- Hidrolik tipi, yaylı tipi.
- Hydraulic type, spring type.
- T veya U kanala kurulum.
- Install in the T-slot or U-slot.

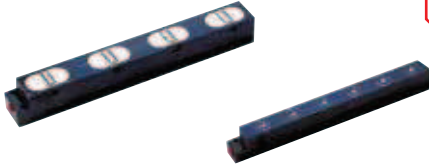
**Kalıp Kaydırma Kolu / Die Arm****Model: RC - RD - RE/RF - RS**

- Tezgah pleyti üzerine kalıp kolayca itilebilir veya çekilebilir.
- Can pull out and push in the die from the plate easily.
- Kaydırma kolunun 4 ayrı modeli vardır.
- There are 4 different models of die arm.

Hava Tahrikli Hidrolik Pompa Ünitesi
Air Driven Hydraulic Pump Unit

- Makinelerde basınç denetleme ve interlock özelliği.
- Capable of pressure inspection and interlocking with machines.
- Aygıtlar arası eşit seviyede hareket operasyon güvenliğini sağlar.
- The movements between each devices will be pinned down mutually in order to ensure operational safety.

Kalıp Pabucu / Die Clamp**Model : CA - CV - CB - CC**

- Kalıbı bağlamak için civata kullanılan geleneksel metodların yerini alır.
- Replacing the traditional method which uses screws to fix dies.
- Ürün "T" kanal pleytli tezgahlarda kullanılır.
- Using T-slots to lock or fix directly on the plate.



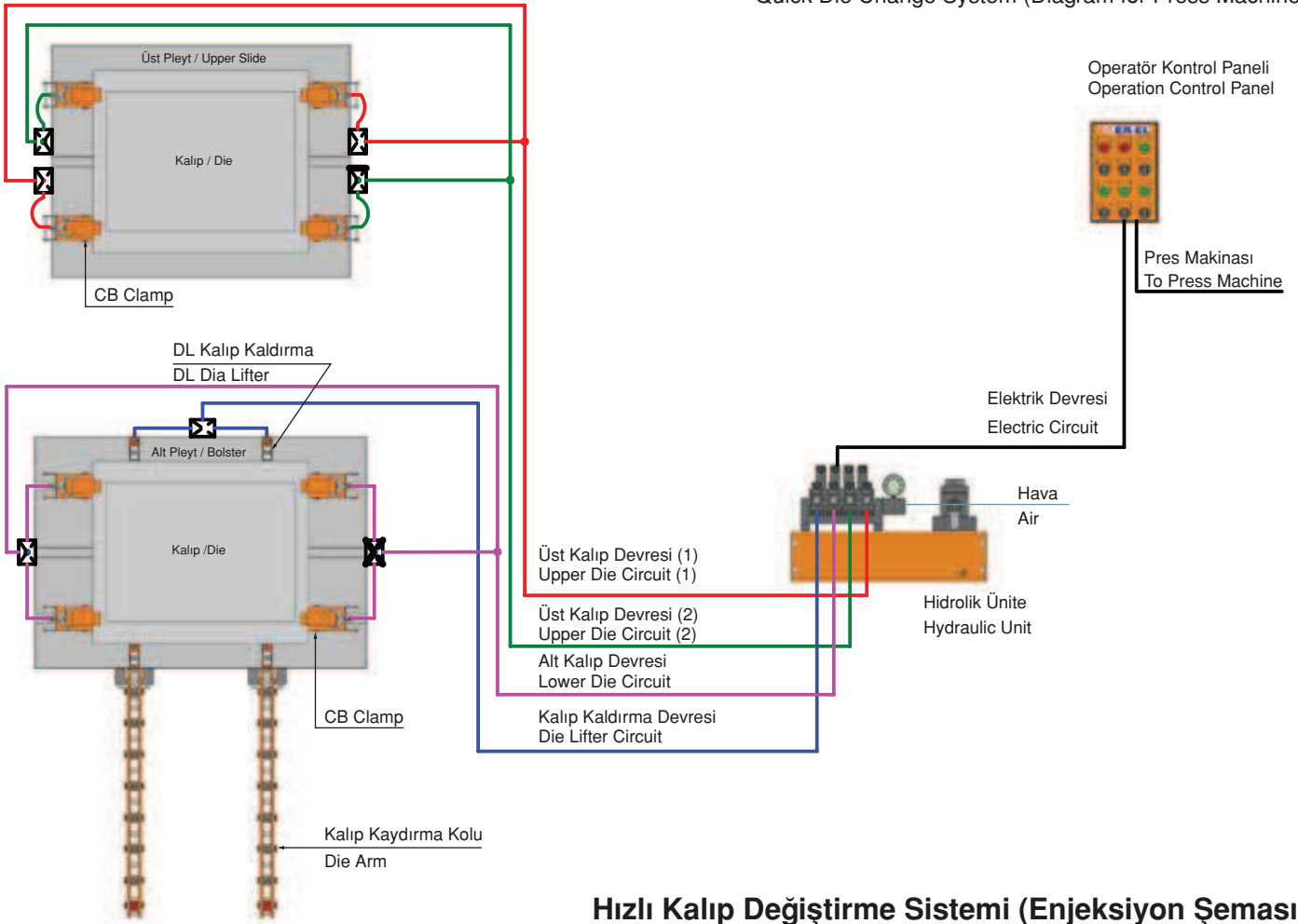

Hızlı Kalıp Değişirme Sistemi (Enjeksiyon Şeması)

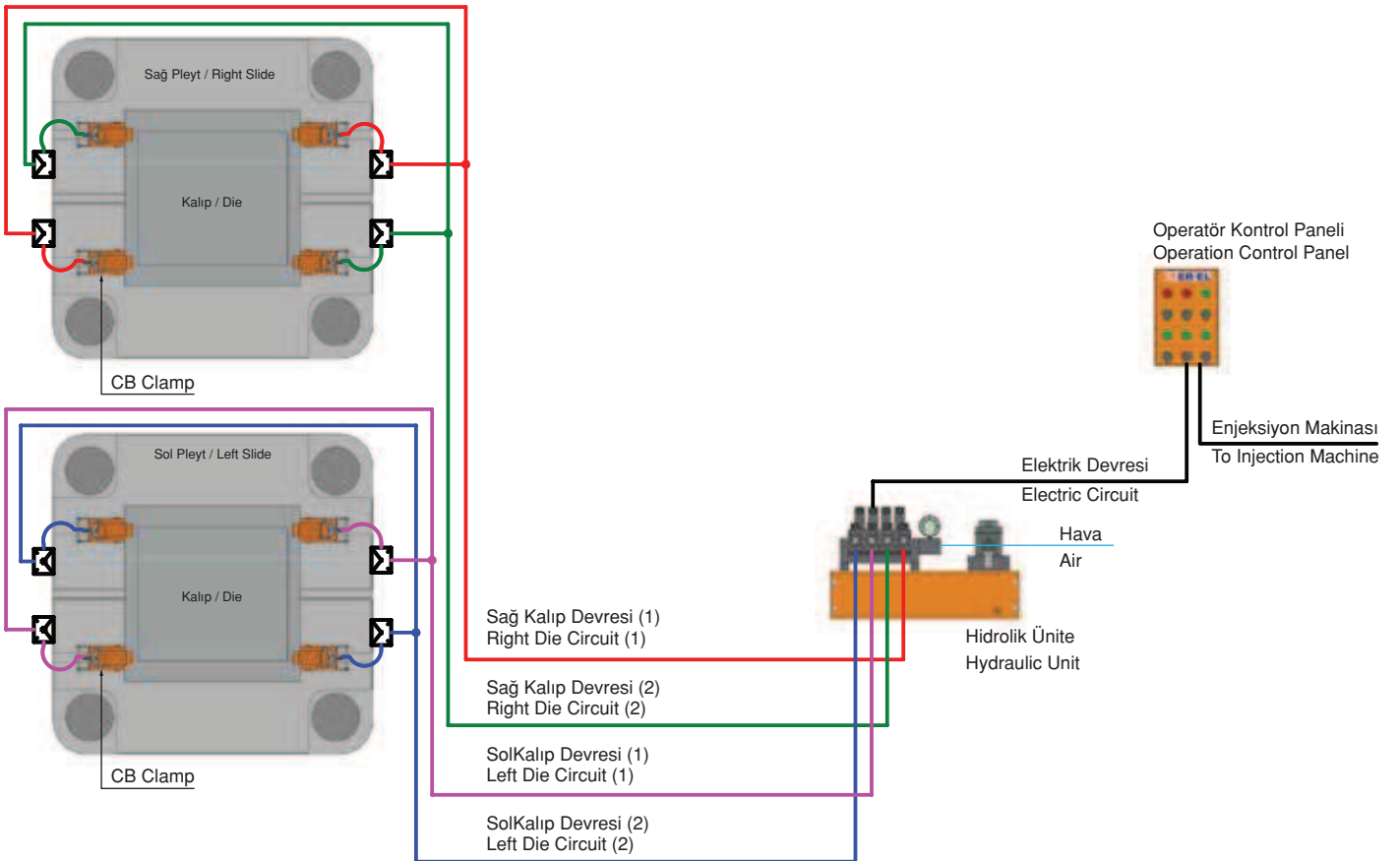

Kalıbı yükleyin.

Bir vinç veya forklift kullanarak kalıbı yükleyin.
Kalıp kaydırma kolu ile kolay yükleme imkanı sağlar.

Load the die

Load the die using a crane or forklift.
The pre-rollers enable easy loading.

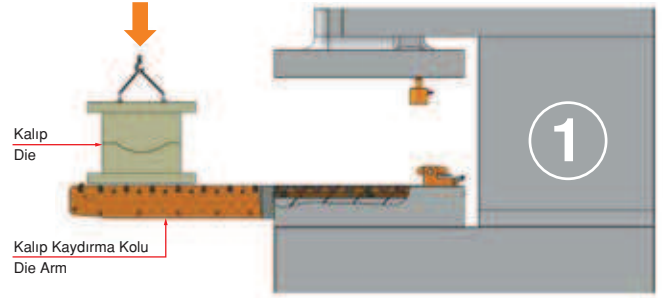
**Kalıbı pleyte aktarın.**

Kalıp kaydırma kolu kalıp kaldırımlarla kalıbı hareket ettirmek için çok az kuvvet gerekir. Kalıp kaldırımları T - / U - kanallarına yerleştirilmiştir. Kalıp kaldırma: Hidrolik basınç **ON**

Transfer the die to the bolster.

With the pre-rollers and die lifters, minimal force is required to move the die. Die lifters are set in the T - / U - slots. Die Lifter : Hydraulic pressure **ON**

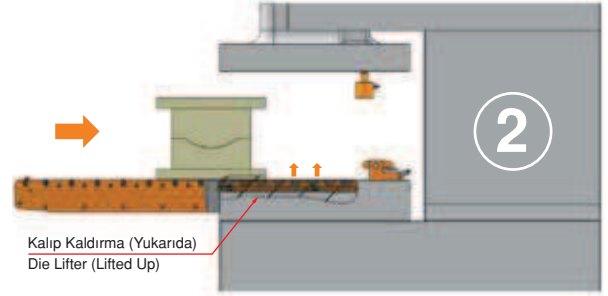
**Pleytin üzerinde kalıbı ayarlayın.**

Kontrol panelinden butona basarak kalıp kaldırmacı indirilir ve kalıp pleyte temas eder. Kalıp Kaldırma : Hidrolik Basınç **OFF**

Set the die on the bolster.

With push-button operation, the die lifter releases and the die makes contact with the bolster. Die Lifter : Hydraulic Pressure **OFF**

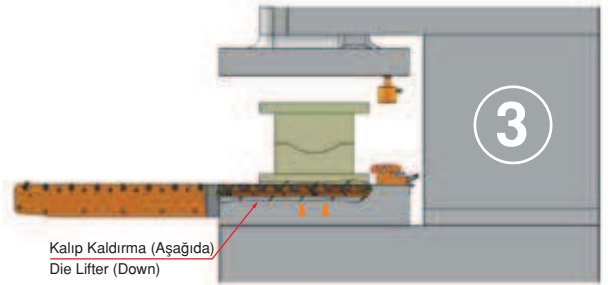
**Hidrolik pabuçları ayarlayın.**

Hidrolik pabuçları kalıba göre ayarlayın. Hidrolik pabuçları T kanalları üzerine kaydırarak kalıba yaklaştırın. Hidrolik Pabuç : Hidrolik Basınç **OFF**

Set the automatic clamps.

Set the slide to the bottom dead center . Slide automatic clamps on the T -slot and bring them near the die. Hydraulic Clamp : Hydraulic Pressure **OFF**

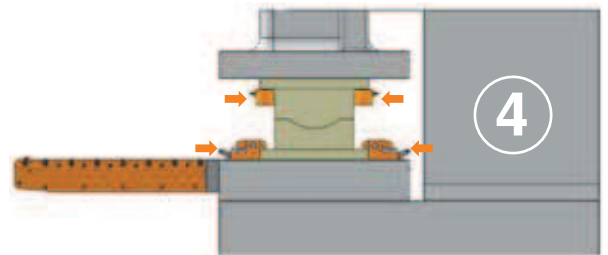
**Kalıbı kilitle.**

Kontrol panelinden butona basarak hidrolik pabuçlarla kalıbı kilitleyin. Güvenlik onayından sonra kalıp kaydırma kolu çıkarılabilir. Hidrolik Pabuç : Hidrolik Basınç **ON**

Lock the die.

With push-button operation, automatic clamps lock the die. After safety confirmation, the pre-roller can be removed. Hydraulic Clamp : Hydraulic Pressure **ON**

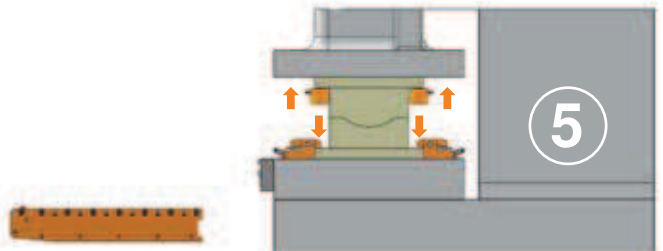

Model		CA-1	CA-2	CA-4	CA-6	CA-10	CA-16	CA-25
Bağlama kapasitesi Capacity of clamp	Ton	1	2	4	6	10	16	25
Toplam strok (X) Total stroke (X)	mm	6	8	8	8	8	8	8
Pabuç strok (Y) Stroke of clamp (Y)	mm	3	4	4	4	4	4	4
Muhafaza edilen strok (Z) Preserved stroke (Z)	mm	3	4	4	4	4	4	4
Silindirin toplam hacmi Total volumn of cylinder	cc	3	7	13	21	32	54	76
Kalıp taban kalınlığı toleransı (H) The tolerance of the template thickness (H)	mm	±1.5	±2	±2	±2	±2	±2	±2

Hidrolik basınç / Hydraulic pressure : 250kgf/cm²



- Satın almadan önce T-Kanal (a,b,c,d) ölçüsü ve kalıp tabanı kalınlığını (H) bildiriniz.
- Please indicate the size of T-slot (a,b,c,d) and the thickness (H) of the template for the die when purchasing.

Referans Nr.	ØF	E	ØG	ØJ	H+d max.	L max.	a min.	K	P
1010-CA01	44	48	12	30	60	12	8	9.5	PT1/8
1010-CA02	53	52	16	48	80	17	12	12	PT1/8
1010-CA04	65	58	23	58	90	20	16	15	PT1/4
1010-CA06	82	65	30	64	100	25	18	15	PT1/4
1010-CA10	99	71	38	78	110	30	22	15	PT1/4
1010-CA16	126	82	45	88	120	38	28	17	PT1/4
1010-CA25	150	100	55	98	140	45	36	23	PT1/4

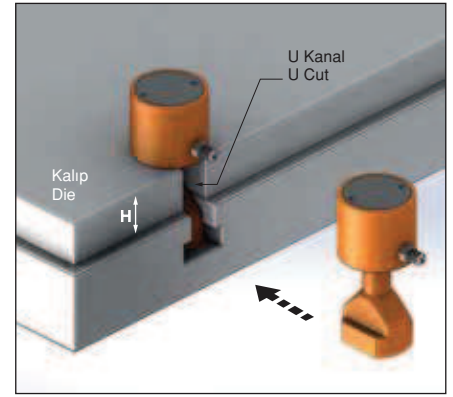

Ürün Nr. 1010 Hidrolik Pabuç Model CA

- Pabuç ölçüleri (A), (B) ve (C) T-Kanala bağlı olarak belirlenir.
- Eğer pabuç ölçüsü (H+d) yukarıdaki maksimum değerlerden fazla ise, özel tasarım olarak kabul edilir.
- Standart Sıcaklık : 60°
- Opsiyonel Sıcaklık : 160°

Product Nr. 1010 Hydraulic Clamp Model CA

- The sizes of clamps (A),(B) and (C) are made based on the size of T slot.
- If the thickness of clamp (H+d) is more than the max. value listed on the left, it will be regarded as special pattern.
- Standard Temperature : 60°
- Optional Temperature : 160°

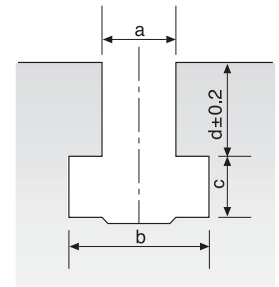
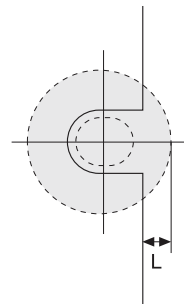
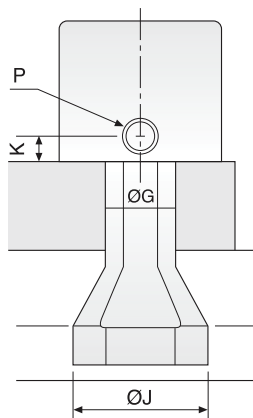
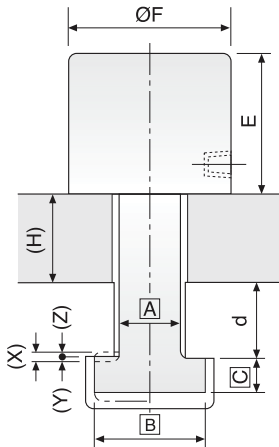

L: Pabuç için şablonun uzunluğu
L: Template's length for clamp

Model		CV-4	CV-6	CV-10
Bağlama kapasitesi Capacity of clamp	Ton	4	6	10
Toplam strok (X) Total stroke (X)	mm	8	8	8
Pabuç strok (Y) Stroke of clamp (Y)	mm	4	4	4
Muhafaza edilen strok (Z) Preserved stroke (Z)	mm	4	4	4
Silindirin toplam hacmi Total volumn of cylinder	cc	13	21	32
Kalıp taban kalınlığı toleransı (H) The tolerance of the template thickness (H)	mm	±2	±2	±2

Hidrolik basınç / Hydraulic pressure : 250kgf/cm²



Referans Nr.		A	B	C	D	E + K1	Ayar Mesafesi	F	Max. L	M	ØG	ØJ	K	P
1010-CV042020125	20	19.6	32	12	85	70	15	65	125	M20	20	58	15	PT 1/4
1010-CV042022160	20	19.6	32	12	110	70	40	65	160	M20	20	58	15	PT 1/4
1010-CV042020160	22	21.6	35	14	85	70	15	65	125	M20	20	58	15	PT 1/4
1010-CV042022125	22	21.6	35	14	110	70	40	65	160	M20	20	58	15	PT 1/4
1010-CV062424125	24	23.6	40	16	85	77	8	82	125	M24	24	64	15	PT 1/4
1010-CV062424160	24	23.6	40	16	110	77	33	82	160	M24	24	64	15	PT 1/4
1010-CV062428125	28	27.6	44	18	85	77	8	82	125	M24	24	64	15	PT 1/4
1010-CV062428160	28	27.6	44	18	110	77	33	82	160	M24	24	64	15	PT 1/4
1010-CV102727160	27	26.6	46	18	110	83	27	99	160	M27	27	78	15	PT 1/4
1010-CV102727200	27	26.6	46	18	125	83	42	99	200	M27	27	78	15	PT 1/4
1010-CV102732160	32	31.6	50	20	110	83	27	99	160	M27	27	78	15	PT 1/4
1010-CV102732200	32	31.6	50	20	125	83	42	99	200	M27	27	78	15	PT 1/4

Ürün Nr. 1010 Hidrolik Pabuç Model CV

- Vidalanarak mesafe ayarı yapılabilir.
- Standart Sıcaklık : 60°
- Opsiyonel Sıcaklık : 160°

Product Nr. 1010 Hydraulic Clamp Model CV

- Screw-distance adjustment can be made.
- Standard Temperature : 60°
- Optional Temperature : 160°

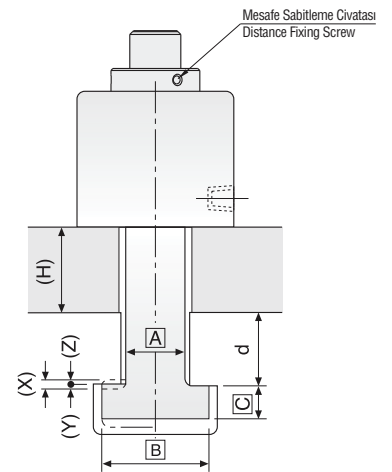
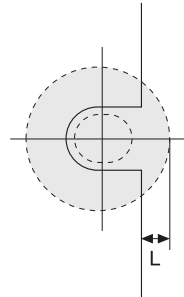
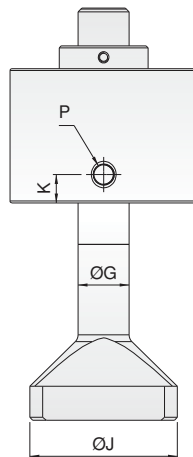
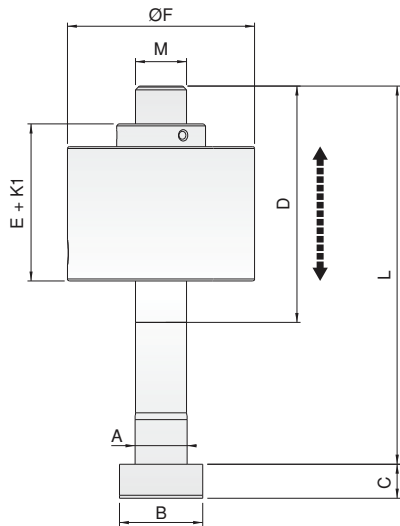

Model		CB-1	CB-2	CB-4	CB-6	CB-10	CB-16	CB-25
Bağlama kapasitesi Capacity of clamp	Ton	1	2	4	6	10	16	25
Toplam strok (X) Total stroke (X)	mm	6	8	8	8	8	8	8
Pabuç strok (Y) Stroke of clamp (Y)	mm	2.5	3	3	3	3	3	3
Muhafaza edilen strok (Z) Preserved stroke (Z)	mm	3.5	5	5	5	5	5	5
Silindirin toplam hacmi Total volumn of cylinder	cc	3	7.5	13	21	38	55	98
Kalıp taban kalınlığı toleransı (H) The tolerance of the template thickness (H)	mm	±1.5	±2	±2	±2	±2	±2	±2



- Satın almadan önce T-Kanal (a,b,c,d) ölçüsü ve kalıp tabanı kalınlığını (H) bildiriniz.
- Please indicate the size of T-slot (a,b,c,d) and the thickness (H) of the template for the die when purchasing.

Hidrolik basınç / Hydraulic pressure : 250kgf/cm²

Referans Nr.	L	K	J	H min.	H+d min. max	E min.	F	G	a min.	C min.	P
1015-CB01	74.5	60	14.5	25	100	42	44	20	10	6.5	PT1/8
1015-CB02	110	90	20	25	100	73	68	32	14	10	PT1/4
1015-CB04	134	110	24	25	130	77	79	40	18	12	PT1/4
1015-CB06	159	130	29	30	150	92	96	46	22	14	PT1/4
1015-CB10	189	159	30	40	140	114	117	54	24	16	PT1/4
1015-CB16	230	200	30	40	130	126	129	58	28	20	PT1/4
1015-CB25	265	235	30	45	120	148	156	70	36	23	PT1/4

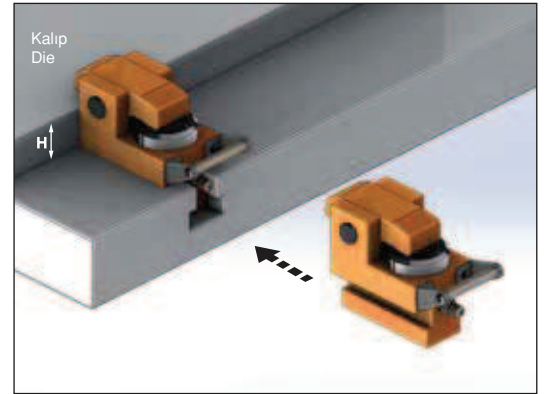

Ürün Nr. 1015 Hidrolik Pabuç Model CB

- Pabuç ölçüleri (A),(B),(C) ve (D) T-Kanala bağlı olarak belirlenir.
- Standart Sıcaklık : 60°
- Opsiyonel Sıcaklık : 160°

Product Nr. 1015 Hydraulic Clamp Model CB

- The sizes of clamps(A),(B),(C) and (D) are made based on the size of T-slot.
- Standard Temperature : 60°
- Optional Temperature : 160°

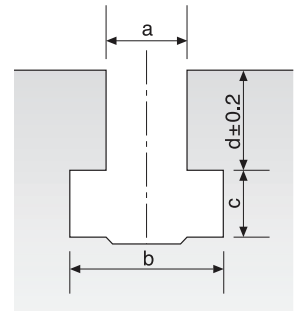
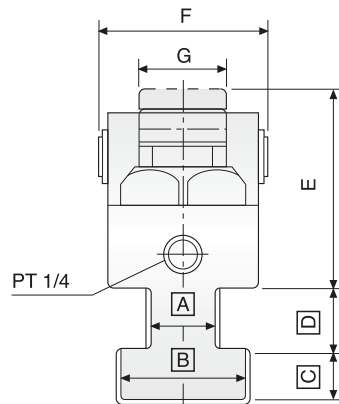
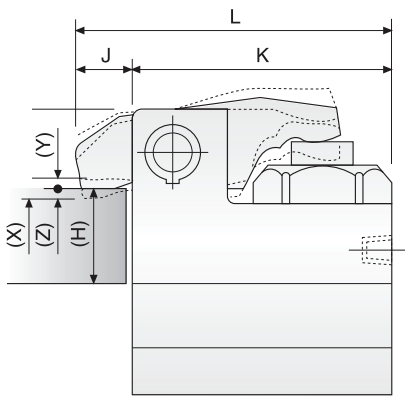

Model		CC-1	CC-2	CC-4	CC-6	CC-10
Bağlama kapasitesi Capacity of clamp	Ton	1	2	4	6	10
Toplam strok (X) Total stroke (X)	mm	9	9	9	12	12
Pabuç strok (Y) Stroke of clamp (Y)	mm	4	4	4	4	4
Muhafaza edilen strok (Z) Preserved stroke (Z)	mm	5	5	5	8	8
Silindirin toplam hacmi Total volumn of cylinder	cc	3	7.5	13	21	38
Kalıp taban kalınlığı toleransı (H) The tolerance of the template thickness (H)	mm	±1.5	±2	±2	±2	±2



- Satın almadan önce T-Kanal (a,b,c,d) ölçüsü ve kalıp tabanı kalınlığını (H) bildiriniz.
- Please indicate the size of T-slot (a,b,c,d) and the thickness (H) of the template for the die when purchasing.

Hidrolik basınç / Hydraulic pressure : 250kgf/cm²

Referans Nr.	H min. - max	A min.	C min.	E	F	G	I	J	K	L min.	M	T	U
1015-CC01	20-35	10	6.5	43	G+43	H+9	Ø16	75	33	27	21.5	1/8	M5
1015-CC02	25-40	14	10	50	G+50	H+9	Ø18	91	43	30	25	1/8	M5
1015-CC04	25-40	18	12	65	G+60	H+9	Ø30	115	55	40	32.5	1/8	M8
1015-CC06	35-55	22	14	80	G+65	H+12	Ø37.5	130	65	48	40	1/4	M10
1015-CC10	40-60	24	16	100	G+82	H+12	Ø50	160	85	60	49	1/4	M12

Ürün Nr. 1015 Hidrolik Pabuç Model CC

- Pabuç ölçüleri (A),(B),(C) ve (D) T-Kanala bağlı olarak belirlenir.
- Standart Sıcaklık : 60°
- Opsiyonel Sıcaklık : 160°

Product Nr. 1015 Hydraulic Clamp Model CC

- The sizes of clamps(A),(B),(C) and (D) are made based on the size of T-slot.
- Standard Temperature : 60°
- Optional Temperature : 160°

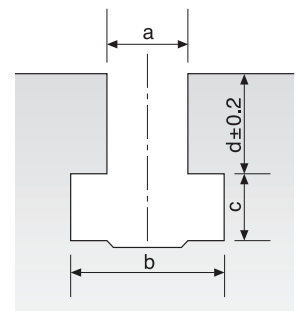
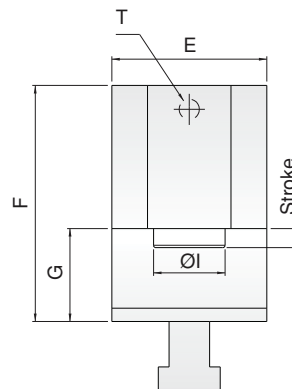
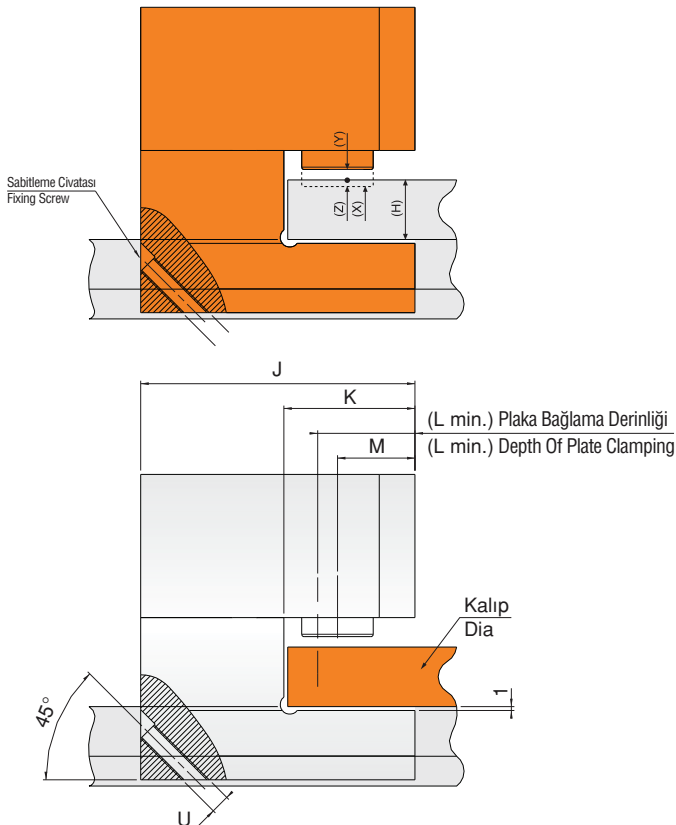
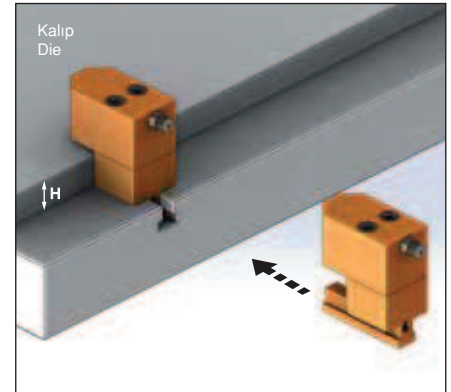

Model		CD-2	CD-4	CD-6	CD-10	CD-16	CD-25
Bağlama kapasitesi Capacity of clamp	Ton	2	4	6	10	16	25
Toplam strok (X) Total stroke (X)	mm	8	8	8	8	8	8
Pabuç strok (Y) Stroke of clamp (Y)	mm	3	3	3	3	3	3
Muhafaza edilen strok (Z) Preserved stroke (Z)	mm	5	5	5	5	5	5
Silindirin toplam hacmi Total volumn of cylinder	cc	7.5	13	21	38	55	98
Kalıp taban kalınlığı toleransı (H) The tolerance of the template thickness (H)	mm	±2	±2	±2	±2	±2	±2



Hidrolik basınç / Hydraulic pressure : 250kgf/cm²

Referans Nr.	A	B	C	D	E min.	F	G	W	N max.	T
1015-CD02	12	20	80	98	90	76	30	124	25	M10x20D
1015-CD04	12	25	100	109	93	87	30	135	30	M12x24D
1015-CD06	15	30	120	126	109	104	30	152	35	M12x24D
1015-CD10	15	35	150	148	131	124	36	174	40	M14x28D
1015-CD16	20	40	200	166	142	138	44	200	50	M18x36D
1015-CD25	20	45	235	200	163	168	48	240	60	M22x45D

Ürün Nr. 1015 Hidrolik Pabuç Model CD

- Standart Sıcaklık : 60°
- Opsiyonel Sıcaklık : 160°

Product Nr. 1015 Hydraulic Clamp Model CD

- Standard Temperature : 60°
- Optional Temperature : 160°

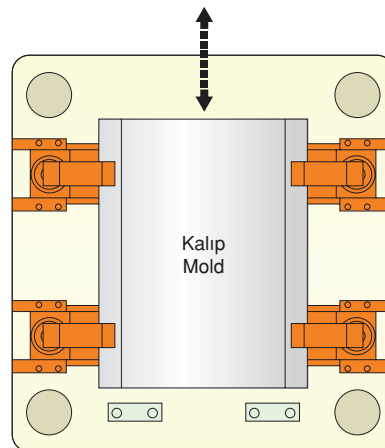
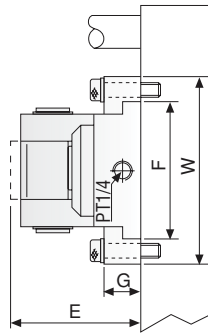
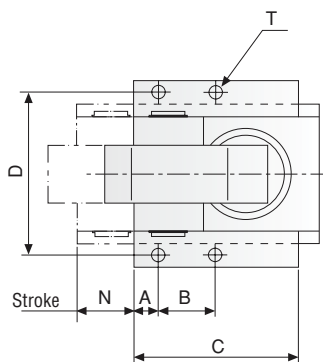

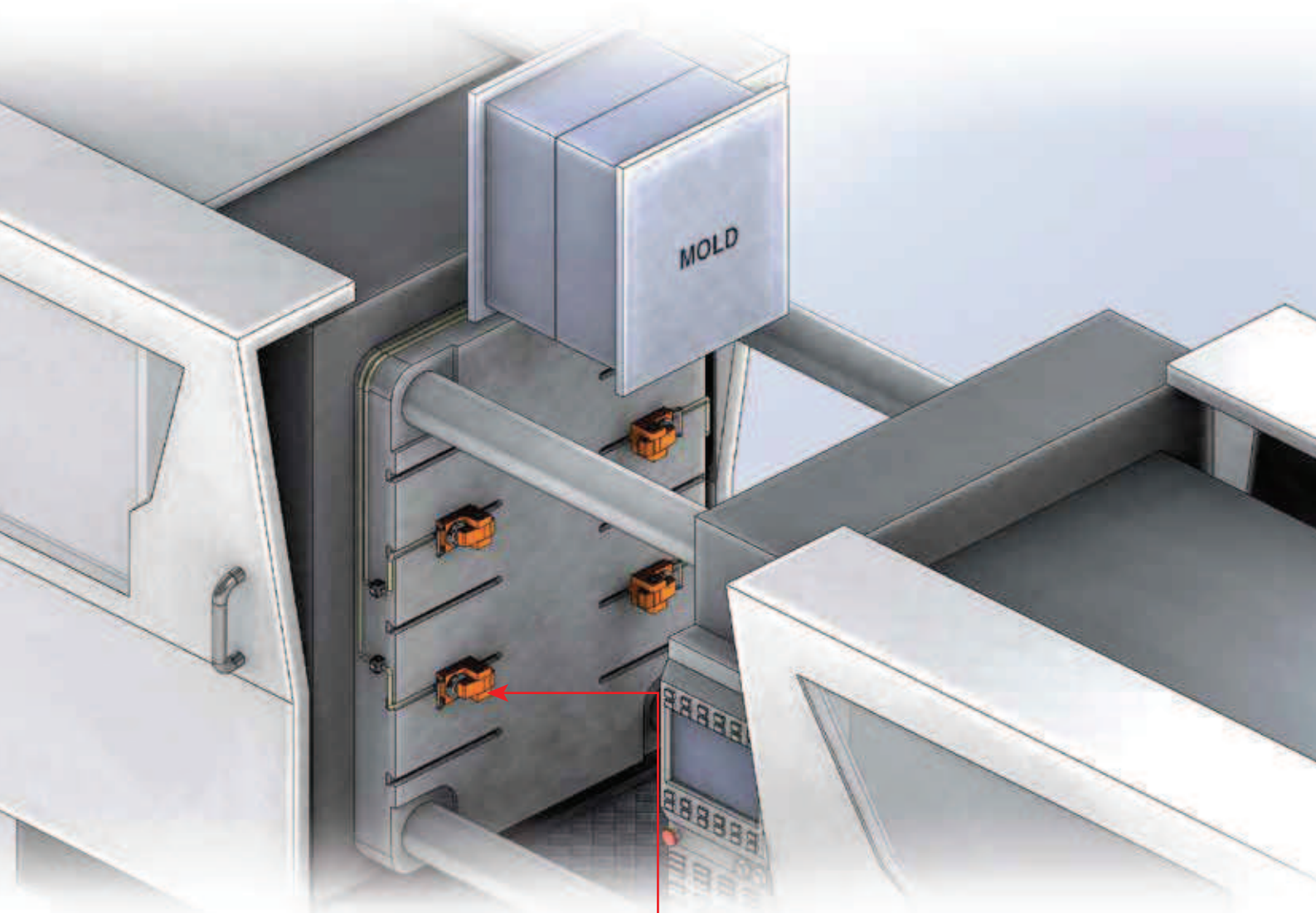

Hidrolik Pabu Modelleri / Hydraulic Clamp Models



Model CA



Model CV



Model CB



Model CC



Model CD

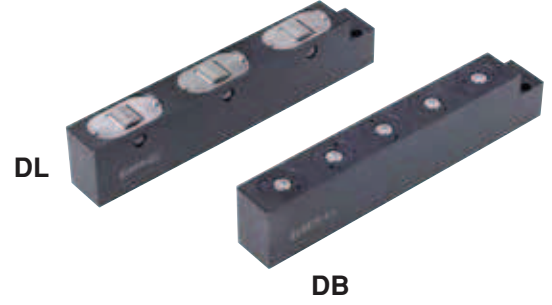
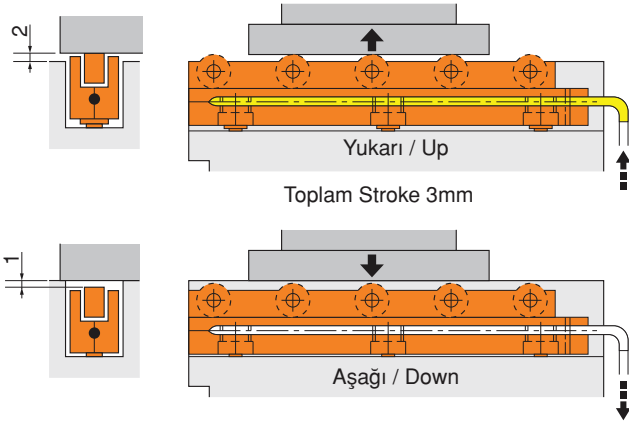

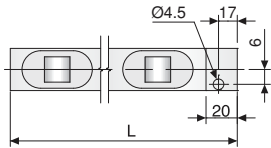
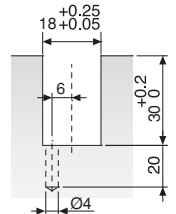
Dış Ölçüler Outline Dimensions	<p>□18 Serisi / Serial</p> 
Pleyt için işlem ölçüsü (U-Kanal) Processing Size for Plate (U-slot)	

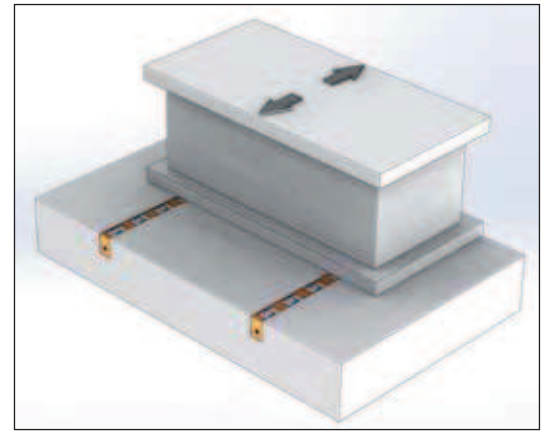

Model DL Hareket Yönü
Model DL Movement Direction

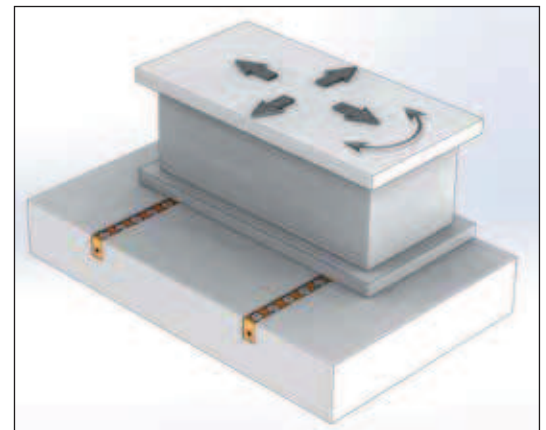

Model DB Hareket Yönü
Model DB Movement Direction

Referans Nr.	L	□18				Hid. Silindir Hyd. cylinder	Piston	Kapasite Capacity kg
		DL18		DB18				
		Rulo Roller (DL)	Kapasite Capacity kg	Misket Ball (DB)	Kapasite Capacity kg			
1020-0200	200	3	300	5	250	2	560	
1020-0300	300	5	500	7	350			
1020-0400	400	6	560	10	500			
1020-0500	500	8	800	12	600	3	840	
1020-0600	600	9	840	15	750			
1020-0700	700	11	840	17	840			
1020-0800	800	12	1120	20	1000	4	1120	
1020-0900	900	14	1120	22	1100			
1020-1000	1000	15	1250	25	1250			

Ürün Nr. 1020 Hidrolik Kalıp Kaldırma Model DL-DB

- Standart Sıcaklık : 60°
- Opsiyonel Sıcaklık : 160°

Product Nr. 1020 Die Lifter Hydraulic Model DL-DB

- Standard Temperature : 60°
- Optional Temperature : 160°

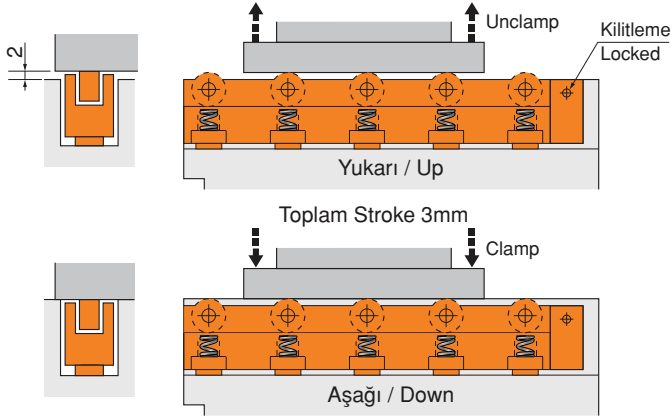

DLS



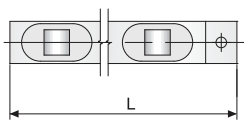
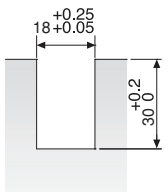

DBS

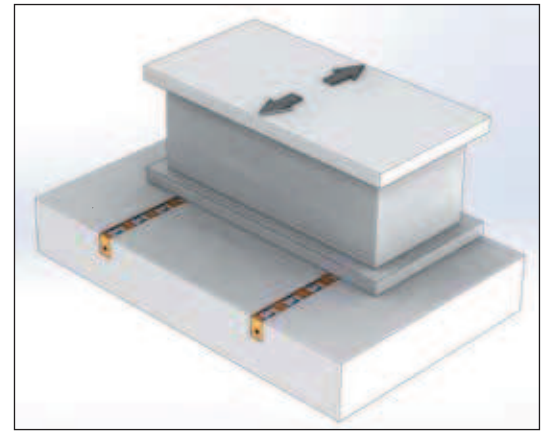
Dış Ölçüler Outline Dimensions	D□18 Serisi / Serial
	
Pleyt için işlem ölçüsü (U-Kanal) Processing Size for Plate (U-slot)	



Model DLS Hareket Yönü
Model DLS Movement Direction

Referans Nr.	L	D□18					
		DLS18			DBS18		
		Rulo Roller (DLS)		Kapasite Capacity kg	Misket Ball (DBS)		Kapasite Capacity kg
1022-0200	200	3	4	200	5	6	150
1022-0300	300	5	6	300	7	8	200
1022-0400	400	6	7	350	10	11	275
1022-0500	500	8	9	450	12	13	325
1022-0600	600	9	10	500	15	16	400
1022-0700	700	11	12	600	17	18	450
1022-0800	800	12	13	650	20	21	525
1022-0900	900	14	15	750	22	23	575
1022-1000	1000	15	16	800	25	26	650

Ürün Nr. 1022 Hidrolik Kalıp Kaldırma Model DLS-DBS

- Standart Sıcaklık : 60°
- Opsiyonel Sıcaklık : 160°

Product Nr. 1022 Die Lifter Hydraulic Model DLS-DBS

- Standard Temperature : 60°
- Optional Temperature : 160°

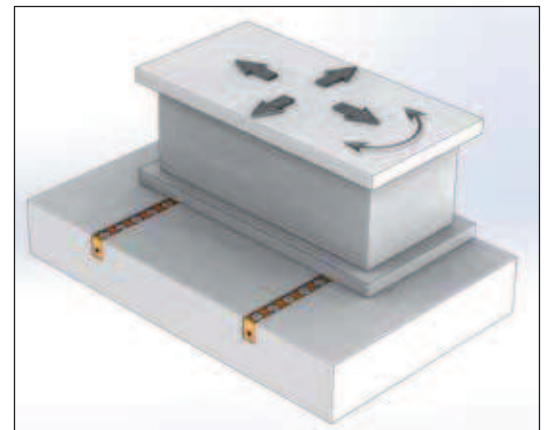

Model DBS Hareket Yönü
Model DBS Movement Direction

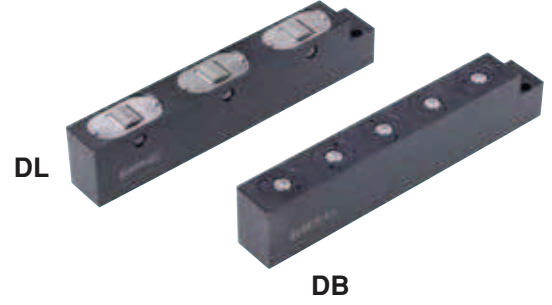
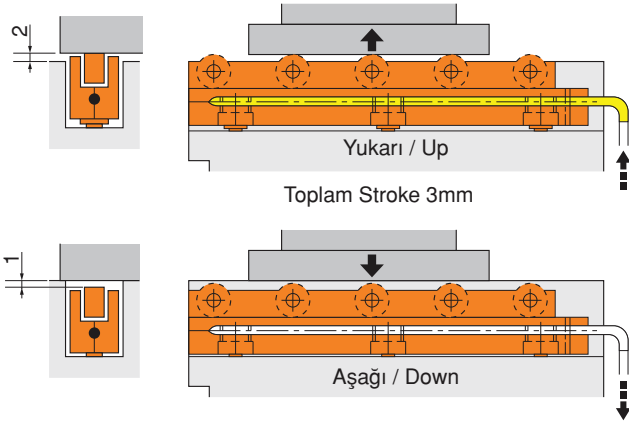

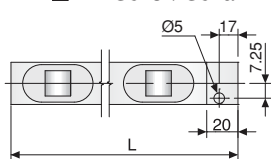
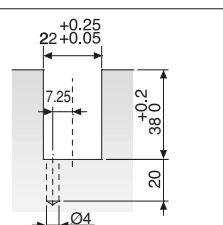
Dış Ölçüler Outline Dimensions	<p>D□22 Serisi / Serial</p> 
Pleyt için işlem ölçüsü (U-Kanal) Processing Size for Plate (U-slot)	

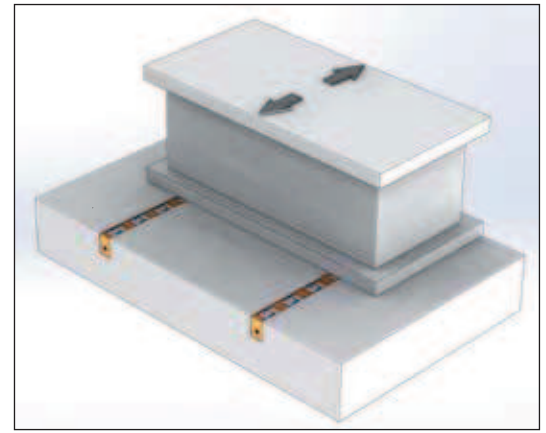

Model DL Hareket Yönü
Model DL Movement Direction

Referans Nr.	L	D□22				Hid. Silindir Hyd. cylinder	
		DL22		DB22		Piston	Kapasite Capacity kg
		Rulo Roller (DL)	Kapasite Capacity kg	Misket Ball (DB)	Kapasite Capacity kg		
1020-0200	200	3	480	5	370	2	1000
1020-0300	300	5	800	7	518		
1020-0400	400	6	960	10	740		
1020-0500	500	8	1280	12	888	3	1500
1020-0600	600	9	1400	15	1110		
1020-0700	700	11	1500	17	1250		
1020-0800	800	12	1920	20	1480	4	2000
1020-0900	900	14	2000	22	1628		
1020-1000	1000	15	2000	25	1850		

Ürün Nr. 1020 Hidrolik Kalıp Kaldırma Model DL-DB

- Standart Sıcaklık : 60°
- Opsiyonel Sıcaklık : 160°

Product Nr. 1020 Die Lifter Hydraulic Model DL-DB

- Standard Temperature : 60°
- Optional Temperature : 160°

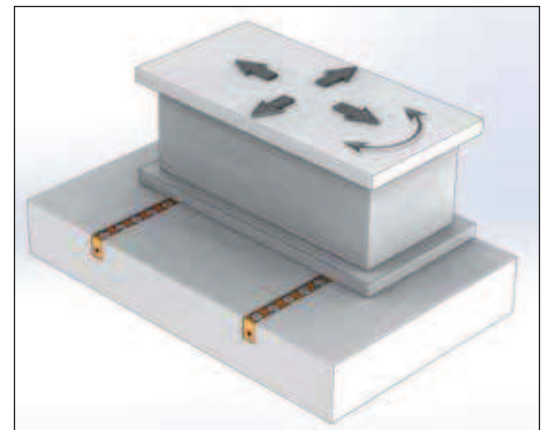

Model DB Hareket Yönü
Model DB Movement Direction

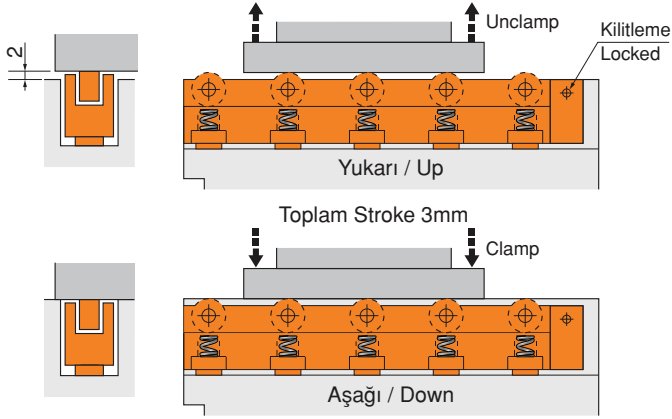

DLS



DBS

Dış Ölçüler Outline Dimensions	D□22 Serisi / Serial
Pleyt için işlem ölçüsü (U-Kanal) Processing Size for Plate (U-slot)	

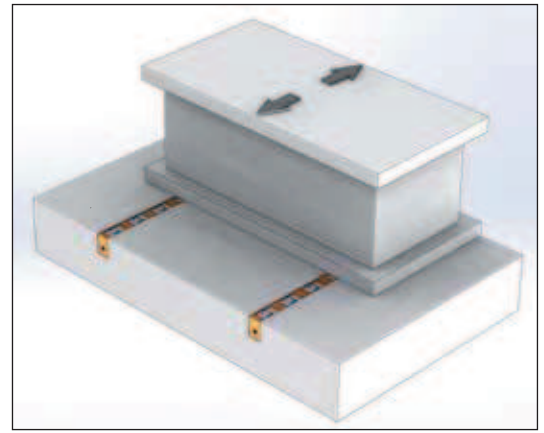

Model DLS Hareket Yönü
Model DLS Movement Direction

Referans Nr.	L	D□22					
		DLS22			DBS22		
		Rulo Roller (DLS)		Kapasite Capacity kg	Misket Ball (DBS)		Kapasite Capacity kg
1022-0200	200	3	3	240	5	5	200
1022-0300	300	5	5	400	7	7	280
1022-0400	400	6	6	480	10	10	400
1022-0500	500	8	8	640	12	12	480
1022-0600	600	9	9	720	15	15	600
1022-0700	700	11	11	880	17	17	680
1022-0800	800	12	12	960	20	20	800
1022-0900	900	14	14	1120	22	22	880
1022-1000	1000	15	15	1200	25	25	1000

Ürün Nr. 1022 Hidrolik Kalıp Kaldırma Model DLS-DBS

- Standart Sıcaklık : 60°
- Opsiyonel Sıcaklık : 160°

Product Nr. 1022 Die Lifter Hydraulic Model DLS-DBS

- Standard Temperature : 60°
- Optional Temperature : 160°

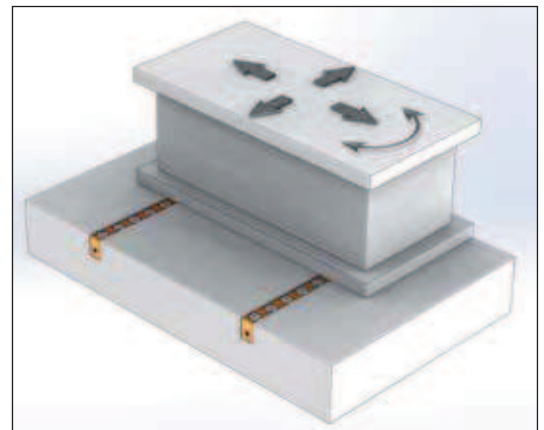

Model DBS Hareket Yönü
Model DBS Movement Direction

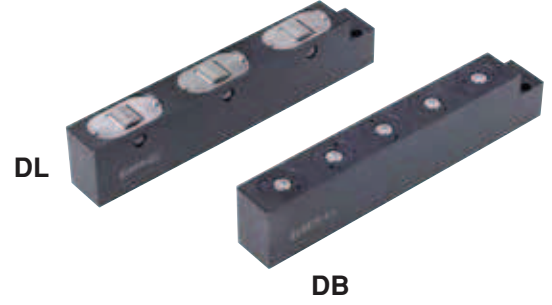
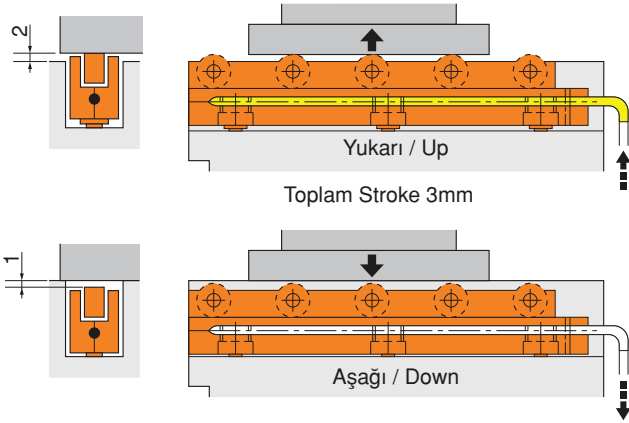

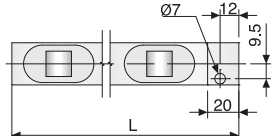
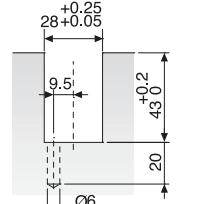
Dış Ölçüler Outline Dimensions	D□28 Serisi / Serial
	
Pleyt için işlem ölçüsü (U-Kanal) Processing Size for Plate (U-slot)	

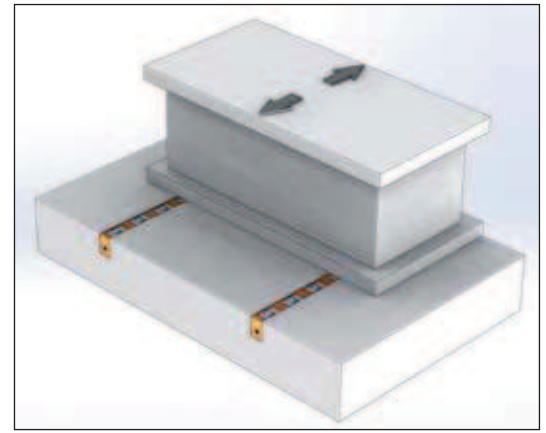

Model DL Hareket Yönü
Model DL Movement Direction

Referans Nr.	L	D□28				Hid. Silindir Hyd. cylinder	
		Rulo Roller (DL)	Kapasite Capacity kg	Misket Ball (DB)	Kapasite Capacity kg	Piston	Kapasite Capacity kg
1020-0200	200	3	750	5	475		
1020-0300	300	5	1250	7	665	2	1260
1020-0400	400	6	1260	10	950		
1020-0500	500	8	1890	12	1140		
1020-0600	600	9	1890	15	1425	3	1890
1020-0700	700	11	1890	17	1615		
1020-0800	800	12	2520	20	1900		
1020-0900	900	14	2520	22	2090	4	2520
1020-1000	1000	15	3150	25	2375		
1020-1100	1100	16	3150	27	2565	5	3150
1020-1200	1200	17	3150	30	2850		
1020-1300	1300	18	3780	32	3040		
1020-1400	1400	19	3780	35	3325	6	3780
1020-1500	1500	20	3780	37	3515		
1020-1600	1600	22	4410	40	3800		
1020-1700	1700	24	4410	42	3990	7	4410
1020-1800	1800	25	4410	45	4275		
1020-1900	1900	27	5040	47	4465	8	5040

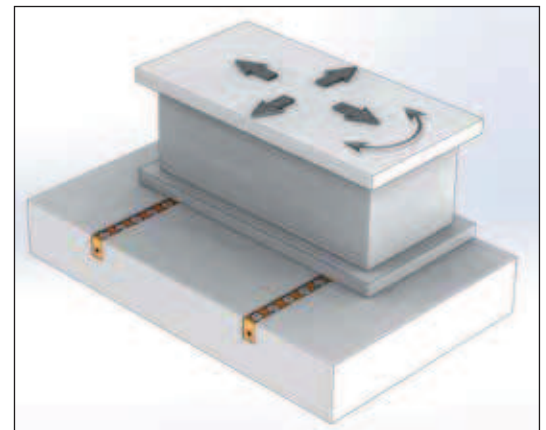

Model DB Hareket Yönü
Model DB Movement Direction

Ürün Nr. 1020 Hidrolik Kalıp Kaldırma Model DL-DB

- Standart Sıcaklık : 60°
- Opsiyonel Sıcaklık : 160°

Product Nr. 1020 Die Lifter Hydraulic Model DL-DB

- Standard Temperature : 60°
- Optional Temperature : 160°

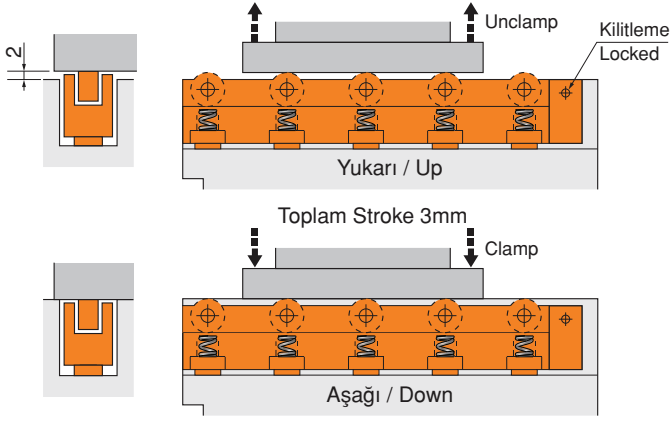

DLS



DBS

Dış Ölçüler Outline Dimensions	D□28 Serisi / Serial
Pleyt için işlem ölçüsü (U-Kanal) Processing Size for Plate (U-slot)	

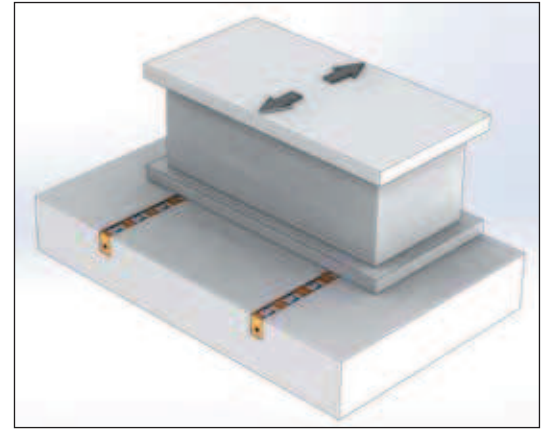

Model DLS Hareket Yönü
Model DLS Movement Direction

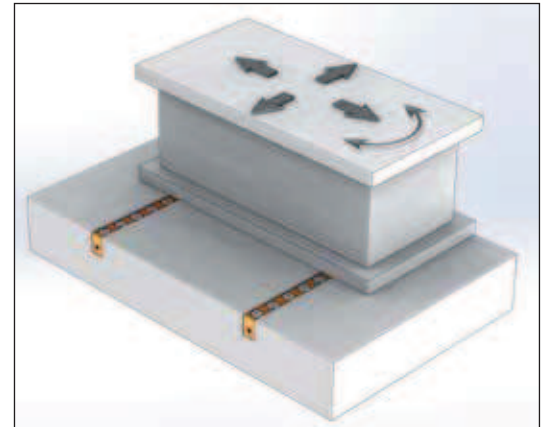

Model DBS Hareket Yönü
Model DBS Movement Direction

Referans Nr.	L	D□28					
		DLS28			DBS28		
		Rulo Roller (DLS)	Kapasite Capacity kg	Misket Ball (DBS)	Kapasite Capacity kg	Misket Ball (DBS)	Kapasite Capacity kg
1022-0200	200	3	4	500	5	5	315
1022-0300	300	5	6	750	7	7	441
1022-0400	400	6	7	875	10	10	630
1022-0500	500	8	9	1125	12	12	756
1022-0600	600	9	10	1250	15	15	945
1022-0700	700	11	12	1500	17	17	1071
1022-0800	800	12	13	1625	20	20	1260
1022-0900	900	14	15	1875	22	22	1386
1022-1000	1000	15	16	2000	25	25	1575
1022-1100	1100	16	17	2125	27	27	1701
1022-1200	1200	17	18	2250	30	30	1890
1022-1300	1300	18	19	2375	32	32	2016
1022-1400	1400	19	20	2500	35	35	2205
1022-1500	1500	20	21	2625	37	37	2331
1022-1600	1600	22	23	2875	40	40	2520
1022-1700	1700	24	25	3125	42	42	2646
1022-1800	1800	25	26	3250	45	45	2835
1022-1900	1900	27	28	3500	47	47	2961

Ürün Nr. 1022 Hidrolik Kalıp Kaldırma Model DLS-DBS

- Standart Sıcaklık : 60°
- Opsiyonel Sıcaklık : 160°

Product Nr. 1022 Die Lifter Hydraulic Model DLS-DBS

- Standard Temperature : 60°
- Optional Temperature : 160°

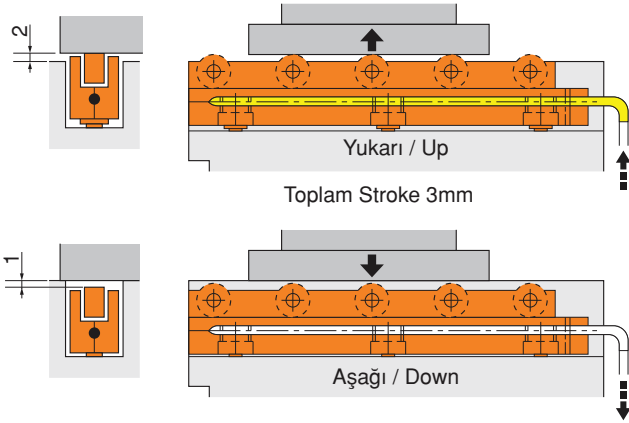

DL

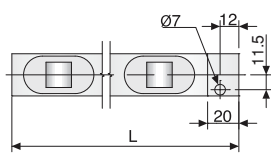
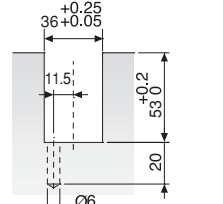

DB

Dış Ölçüler Outline Dimensions	D□36 Serisi / Serial 
Pleyt için işlem ölçüsü (U-Kanal) Processing Size for Plate (U-slot)	

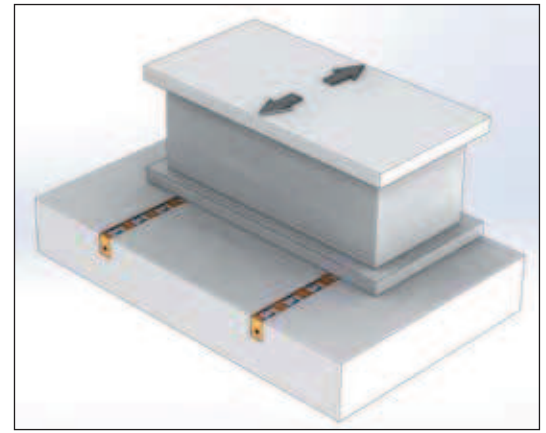

Model DL Hareket Yönü
Model DL Movement Direction

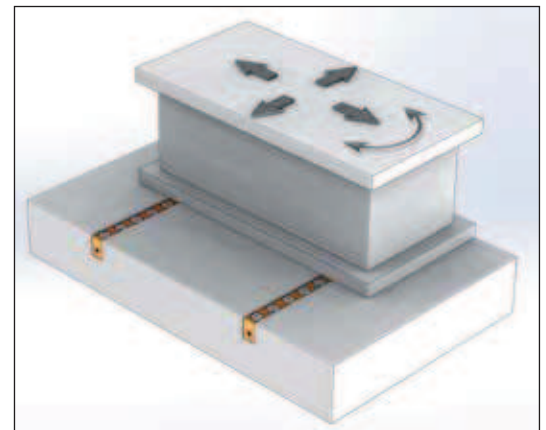

Model DB Hareket Yönü
Model DB Movement Direction

Referans Nr.	L	D□36				Hid. Silindir Hyd. cylinder	
		Rulo Roller (DL)	Kapasite Capacity kg	Misket Ball (DB)	Kapasite Capacity kg	Piston	Kapasite Capacity kg
1020-0200	200	3	1050	5	600		
1020-0300	300	5	1750	7	840	2	1700
1020-0400	400	6	1700	10	1200		
1020-0500	500	8	2600	12	1440		
1020-0600	600	9	2600	15	1800		
1020-0700	700	11	2600	17	2040	3	2600
1020-0800	800	12	2600	20	2400		
1020-0900	900	14	3500	22	2640		
1020-1000	1000	15	3500	25	3000	4	3500
1020-1100	1100	16	3500	27	3240		
1020-1200	1200	17	4400	30	3600		
1020-1300	1300	18	4400	32	3840		
1020-1400	1400	19	4400	35	4200	5	4400
1020-1500	1500	20	4400	37	4400		
1020-1600	1600	22	5300	40	4800		
1020-1700	1700	24	5300	42	5040		
1020-1800	1800	25	5300	45	5300	6	5300
1020-1900	1900	27	5300	47	5300		

Ürün Nr. 1020 Hidrolik Kalıp Kaldırma Model DL-DB

- Standart Sıcaklık : 60°
- Opsiyonel Sıcaklık : 160°

Product Nr. 1020 Die Lifter Hydraulic Model DL-DB

- Standard Temperature : 60°
- Optional Temperature : 160°

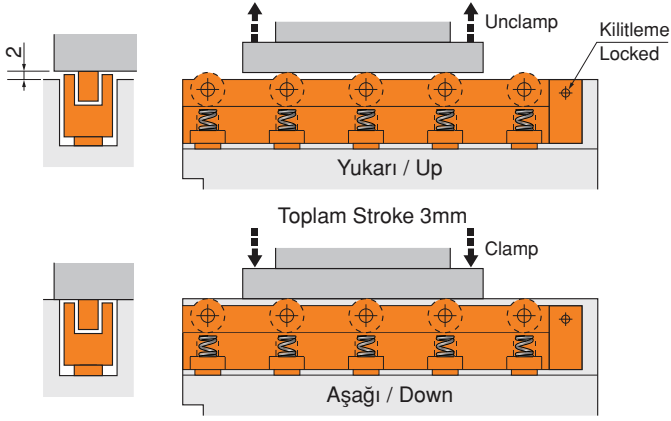

DLS



DBS

Dış Ölçüler Outline Dimensions	D□36 Serisi / Serial
Pleyt için işlem ölçüsü (U-Kanal) Processing Size for Plate (U-slot)	

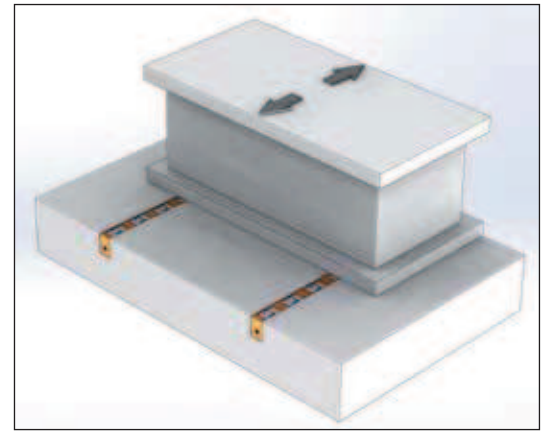

Model DLS Hareket Yönü
Model DLS Movement Direction

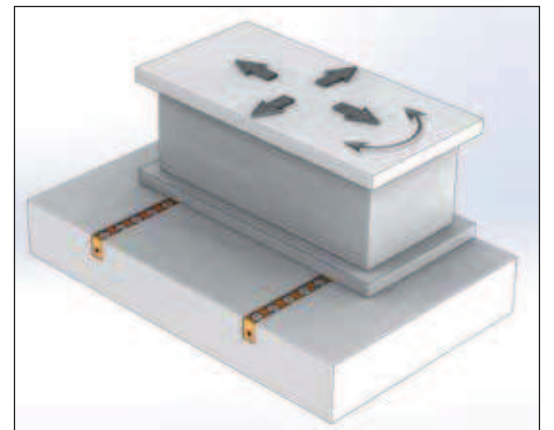

Model DBS Hareket Yönü
Model DBS Movement Direction

Referans Nr.	L	D□36					
		DLS36			DBS36		
		Rulo Roller (DLS)		Kapasite Capacity kg	Misket Ball (DBS)		Kapasite Capacity kg
1022-0200	200	3	3	600	5	5	500
1022-0300	300	5	5	1000	7	7	700
1022-0400	400	6	6	1200	10	10	1000
1022-0500	500	8	8	1600	12	12	1200
1022-0600	600	9	9	1800	15	15	1500
1022-0700	700	11	11	2200	17	17	1700
1022-0800	800	12	12	2400	20	20	2000
1022-0900	900	14	14	2800	22	22	2200
1022-1000	1000	15	15	3000	25	25	2500
1022-1100	1100	16	16	3200	27	27	2700
1022-1200	1200	17	17	3400	30	30	3000
1022-1300	1300	18	18	3600	32	32	3200
1022-1400	1400	19	19	3800	35	35	3500
1022-1500	1500	20	20	4000	37	37	3700
1022-1600	1600	22	22	4400	40	40	4000
1022-1700	1700	24	24	4800	42	42	4200
1022-1800	1800	25	25	5000	45	45	4500
1022-1900	1900	27	27	5400	47	47	4700

Ürün Nr. 1022 Hidrolik Kalıp Kaldırma Model DLS-DBS

- Standart Sıcaklık : 60°
- Opsiyonel Sıcaklık : 160°

Product Nr. 1022 Die Lifter Hydraulic Model DLS-DBS

- Standard Temperature : 60°
- Optional Temperature : 160°

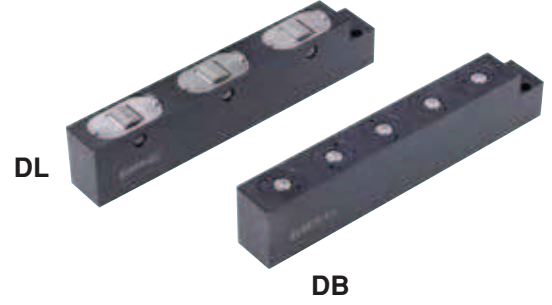
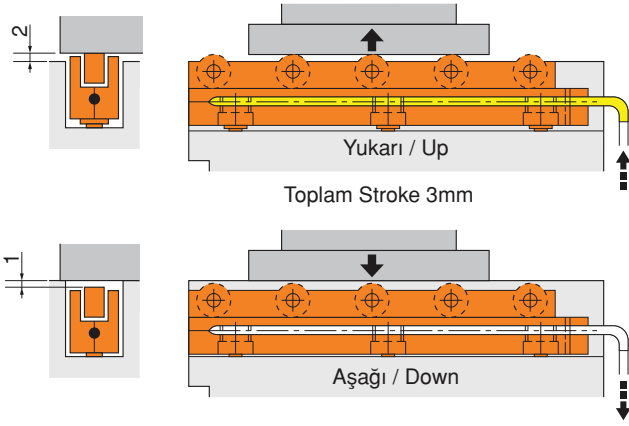

Dış Ölçüler Outline Dimensions	D□50 Serisi / Serial DL50-2100'den önce	D□50 Serisi / Serial DL50-2100'den sonra
Pleyt için işlem ölçüsü (U-Kanal) Processing Size for Plate (U-slot)		

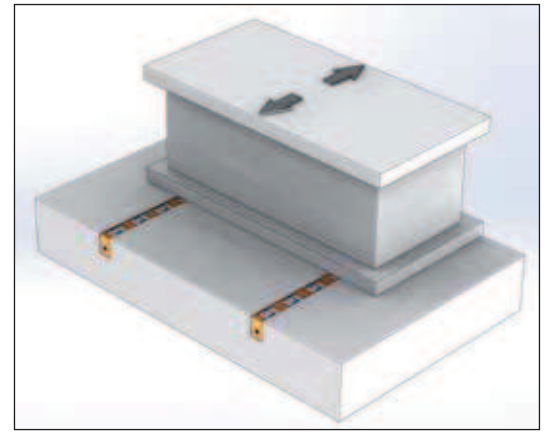

Model DL Hareket Yönü
Model DL Movement Direction

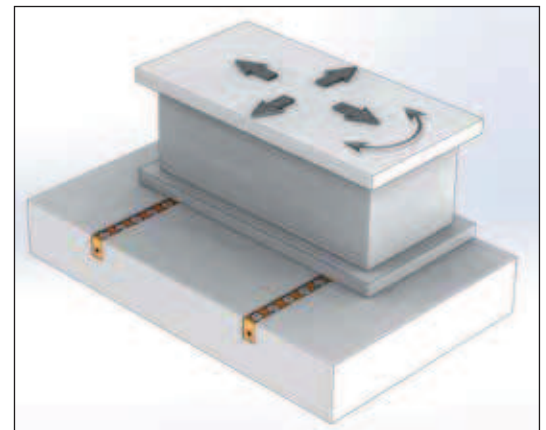

Model DB Hareket Yönü
Model DB Movement Direction

Referans Nr.	L	D□50				Hid. Silindir Hyd. cylinder	
		DL50		DB50		Piston	Kapasite Capacity kg
		Rulo Roller (DL)	Kapasite Capacity kg	Misket Ball (DB)	Kapasite Capacity kg		
1020-0200	200	2	1000	4	640	2	2200
1020-0300	300	3	1500	6	960		
1020-0400	400	4	2000	9	1440		
1020-0500	500	5	2500	11	1760	3	3300
1020-0600	600	6	3000	13	2080		
1020-0700	700	7	3300	16	2560		
1020-0800	800	8	3300	18	2880	4	4400
1020-0900	900	9	4400	20	3200		
1020-1000	1000	10	4400	23	3680		
1020-1100	1100	11	4400	25	4000	5	5500
1020-1200	1200	12	5500	27	4320		
1020-1300	1300	13	5500	29	4640		
1020-1400	1400	14	5500	31	4960	6	6600
1020-1500	1500	15	5500	33	5280		
1020-1600	1600	16	6500	35	5600		
1020-1700	1700	17	6500	38	6080	7	7700
1020-1800	1800	18	6500	40	6400		
1020-1900	1900	19	6500	42	6720		
1020-2000	2000	20	7700	44	7040	8	8800
1020-2100	2100	21	7700	46	7360		
1020-2200	2200	22	7700	48	7680		
1020-2300	2300	23	7700	50	7700	8	8800
1020-2400	2400	24	8800	52	8320		
1020-2500	2500	25	8800	54	8640		

Ürün Nr. 1020 Hidrolik Kalıp Kaldırma Model DL-DB

- Standart Sıcaklık : 60°
- Opsiyonel Sıcaklık : 160°

Product Nr. 1020 Die Lifter Hydraulic Model DL-DB

- Standard Temperature : 60°
- Optional Temperature : 160°

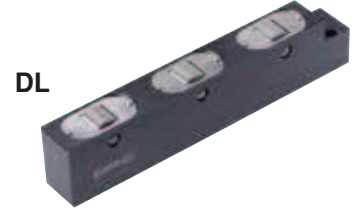
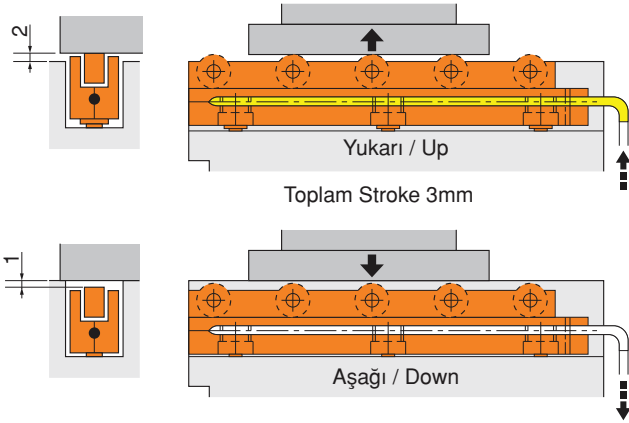

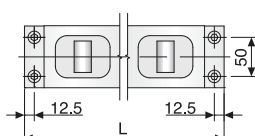
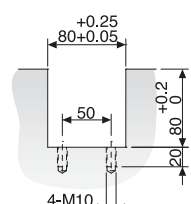
Dış Ölçüler Outline Dimensions	D□80 Serisi / Serial 
Pleyt için işlem ölçüsü (U-Kanal) Processing Size for Plate (U-slot)	

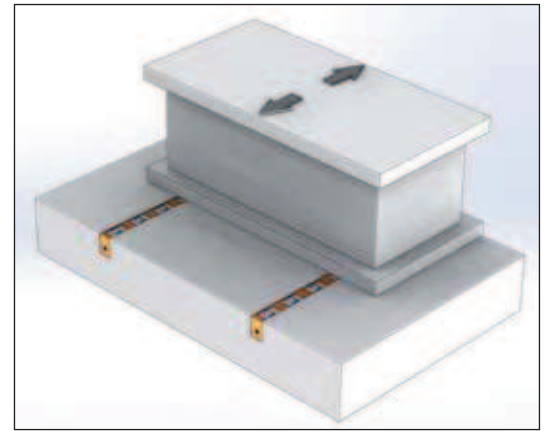

Model DL Hareket Yönü
Model DL Movement Direction

Referans Nr.	L	D□80			
		DL80		Hid. Silindir Hyd. cylinder	
		Rulo Roller (DL)	Kapasite Capacity kg	Piston	Kapasite Capacity kg
1020-0200	200	-	-	-	-
1020-0300	300	-	-	-	-
1020-0400	400	-	-	-	-
1020-0500	500	5	3250	2	5600
1020-0600	600	6	3900		
1020-0700	700	7	4550	3	8400
1020-0800	800	8	5200		
1020-0900	900	9	5850		
1020-1000	1000	10	6500	4	11200
1020-1100	1100	11	7150		
1020-1200	1200	12	7800		
1020-1300	1300	13	8450		
1020-1400	1400	14	9100	5	14000
1020-1500	1500	15	9750		
1020-1600	1600	16	10400	6	16800
1020-1700	1700	17	11050		
1020-1800	1800	18	11700		
1020-1900	1900	19	12350		
1020-2000	2000	20	13000		
1020-2100	2100	21	13650		
1020-2200	2200	22	14300		
1020-2300	2300	23	14950		
1020-2400	2400	24	15600		
1020-2500	2500	25	16250	8	22400

Ürün Nr. 1020 Hidrolik Kalıp Kaldırma Model DL-DB

- Standart Sıcaklık : 60°
- Opsiyonel Sıcaklık : 160°

Product Nr. 1020 Die Lifter Hydraulic Model DL-DB

- Standard Temperature : 60°
- Optional Temperature : 160°

Model RC - RD - RE/RF - RS

Model Seçimi / Model Selection

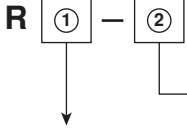

Model	Saklama Metodu / Storage Method	Tanımlama / Specification
C	Demonte / Dismantling	580 mm
D	Asmalı / Hanging	760 mm
E	Katlamalı (kısa) / Folding (short)	880 mm
F	Katlamalı (uzun) / Folding (long)	990 mm

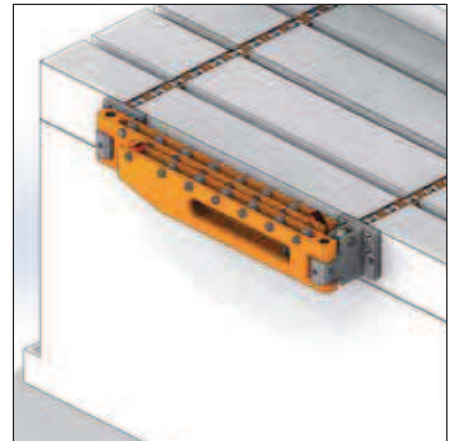
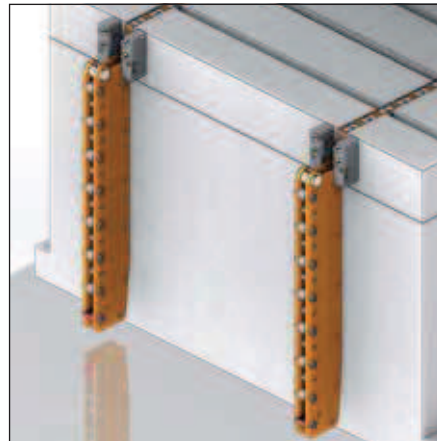
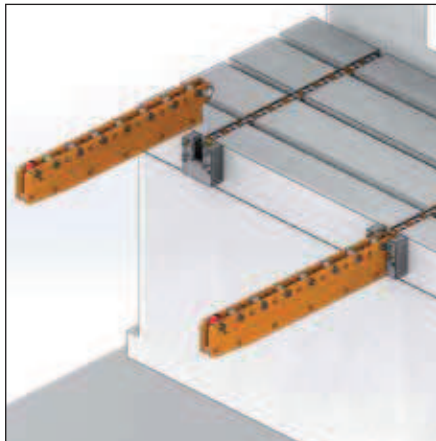
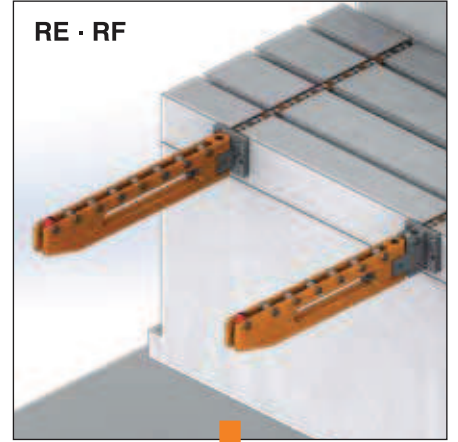
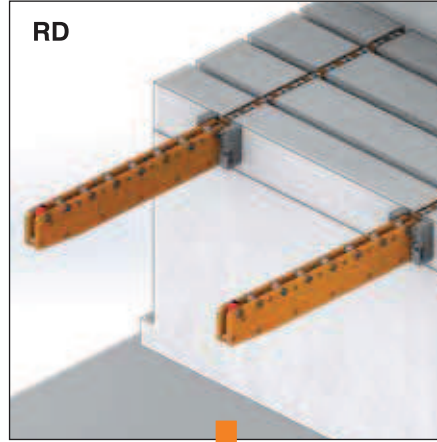
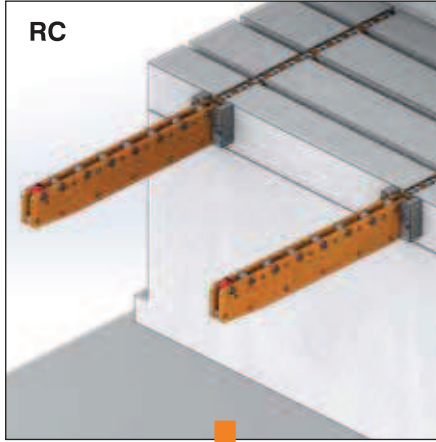
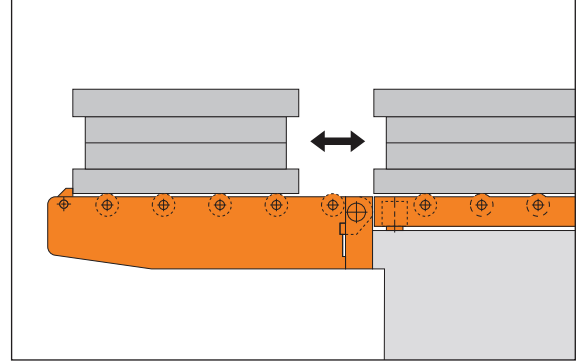

Referans Nr.	Destek Modeli Model of Support	İhtiyaç Duyulan Kalıp uzunluğu Length Needed of the Die L(mm)	Max. Kapasite Max. Capacity (kgf)	Top. Uzunluk Total Length A (mm)	Destek ölçüleri Size of Support			Kurulum için Delik Şekilleri Hole Pattern For Installation	Silindir sayısı Number of Roller
					D	B	H		
1025-RC580	RC-12	500	800	550	48	115	118	A Tipi / A Type	5
1025-RC760	RC-12	700	600	750	48	115	118	A Tipi / A Type	7
1025-RC880	RC-16	800	800	850	48	115	158	B Tipi / B Type	8
1025-RC990	RC-20	900	900	950	48	115	188	B Tipi / B Type	9
1027-RC05125	RC-14H	500	1250	550	55	130	138	C Tipi / C Type	7
1027-RC05160	RC-16H	500	1600	550	55	130	158	C Tipi / C Type	7
1027-RC05200	RC-18H	500	2000	550	55	130	178	C Tipi / C Type	7
1027-RC07125	RC-14H	700	1250	750	55	130	138	C Tipi / C Type	9
1027-RC07160	RC-16H	700	1600	750	55	130	158	C Tipi / C Type	9
1027-RC07200	RC-18H	700	2000	750	55	130	178	C Tipi / C Type	9
1027-RC08125	RC-16H	800	1250	850	55	130	158	C Tipi / C Type	10
1027-RC08160	RC-18H	800	1600	850	55	130	178	C Tipi / C Type	10
1027-RC08200	RC-20H	800	2000	850	55	130	188	C Tipi / C Type	10
1027-RC09160	RC-22H	900	1600	950	55	130	218	C Tipi / C Type	11

Ürün Nr. 1027 Kalıp Kaydırma Kolu Model RC

Product Nr. 1027 Die Arm Model RC

Model RC (Demonte / Dismantling)

- RC modelinde, kol ve destek ayrı olarak kullanılabilir.
- The arm itself and the support in Model RC can be used separately.

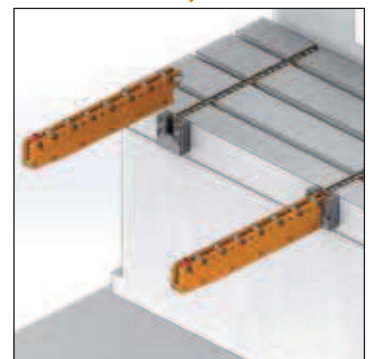
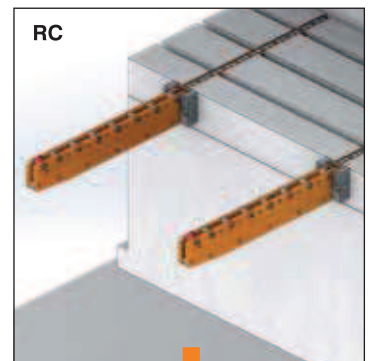
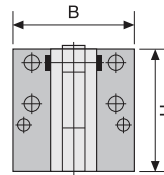
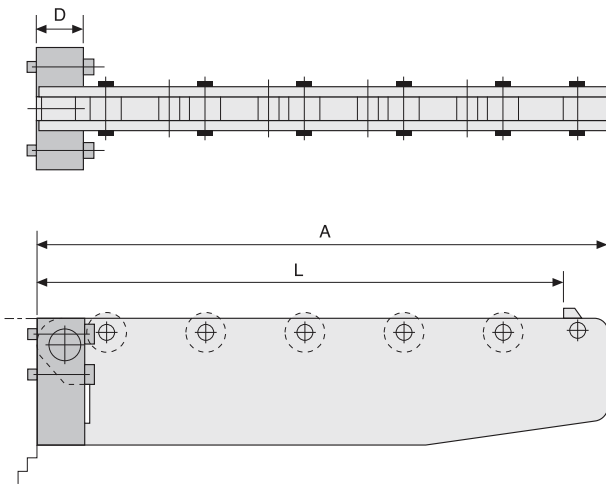
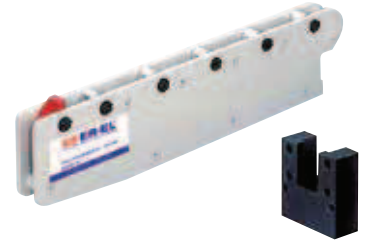

Referans Nr.	İhtiyaç Duyulan Kalıp uzunluğu Length Needed of the Die L(mm)	Max. Kapasite Max. Capacity (kgf)	Top. Uzunluk Total Length A (mm)	Asma Ölçüleri Size of Hanging		Destek Ölçüleri Size of Support			Kurulum İçin Delik Şekilleri Hole Pattern For Installation	Silindir sayısı Number of Roller
				X	Y	D	B	H		
1030-RD580	500	800	550	140	620	52	115	118	A Tipi / A Type	5
1030-RD760	700	600	750	140	820	52	115	118	A Tipi / A Type	7
1030-RD880	800	800	850	180	960	52	115	158	B Tipi / B Type	8
1030-RD990	900	900	950	220	1100	52	115	188	B Tipi / B Type	9
1030-RD05125	500	1250	550	170	645	62	130	138	C Tipi / C Type	7
1030-RD05160	500	1600	550	190	670	62	130	158	C Tipi / C Type	7
1030-RD05200	500	2000	550	210	675	62	130	178	C Tipi / C Type	7
1030-RD07125	700	1250	750	170	840	62	130	138	C Tipi / C Type	9
1030-RD07160	700	1600	750	190	865	62	130	158	C Tipi / C Type	9
1030-RD07200	700	2000	750	210	890	62	130	178	C Tipi / C Type	9
1030-RD08125	800	1250	850	190	960	62	130	158	C Tipi / C Type	10
1030-RD08160	800	1600	850	210	985	62 <td 130	178	C Tipi / C Type	10	
1030-RD08200	800	2000	850	220	995	62	130	188	C Tipi / C Type	10
1030-RD09160	900	1600	950	250	1130	62	130	218	C Tipi / C Type	11

Ürün Nr. 1030 Kalıp Kaydırma Kolu Model RD

Product Nr. 1030 Die Arm Model RD

Model RD (Asmalı / Hanging)

- RD modelinin asma uzunluğu (Y) zemin ve plaka arasındaki yükseklik farkından daha düşük olmalıdır.
- The hanging length (Y) of Model RD should be less than the height between the plate and the ground

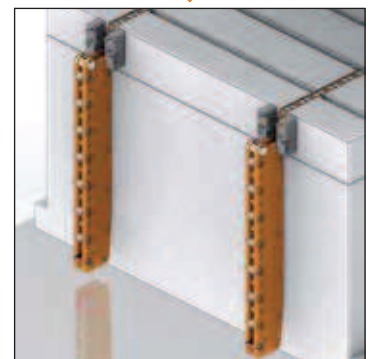
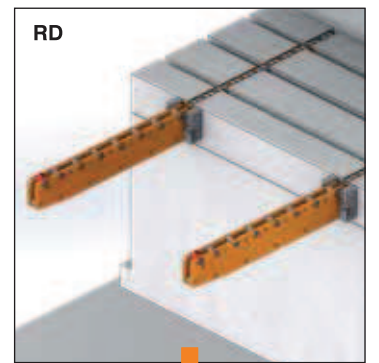
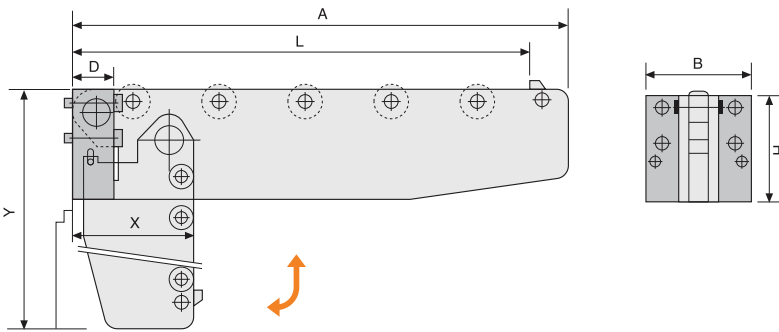

Referans Nr.	İhtiyaç Duyulan Kalıp uzunluğu Length Needed of the Die L (mm)	Max. Kapasite Max. Capacity (kgf)	Top. Uzunluk Total Length A (mm)	Kurulum İçin Gerekli Minimum Mesafe Min. Distance for Installation C (mm)	Katlı Haliyle Ölçüler Size of Fold Down		Destek ölçüleri Size of Support		Silindir Sayısı Number of Roller	M	N	Kurulum İçin Delik Şekilleri Hole Pattern For Installation
					X	Y	B	H				
1033-RERF580	500	800	550	525	90	150	115	118	5	57	120	A Tipi / A Type
1033-RERF760	700	600	750	725	90	150	115	118	7	57	120	A Tipi / A Type
1033-RERF880	800	800	850	825	90	150	115	158	8	57	120	B Tipi / B Type
1033-RERF990	900	900	950	925	90	150	115	188	9	57	120	B Tipi / B Type

Ürün Nr. 1033 Kalıp Kaydırma Kolu Model RE-RF

- İş bittiğinde sağa veya sola katlanabilir.

Product Nr. 1033 Die Arm Model RE-RF

- Itself can be turned left or right for storage.

Referans Nr.	İhtiyaç Duyulan Kalıp uzunluğu Length Needed of the Die L (mm)	Max. Kapasite Max. Capacity (kgf)	Top. Uzunluk Total Length A (mm)	Kurulum İçin Gerekli Minimum Mesafe Min. Distance for Installation C (mm)	Katlı Haliyle Ölçüler Size of Fold Down		Destek ölçüleri Size of Support		Silindir Sayısı Number of Roller	M	N	Kurulum İçin Delik Şekilleri Hole Pattern For Installation
					X	Y	B	H				
1035-RERF05160	500	1600	550	525	105	170	130	158	7	74	140	C Tipi / C Type
1035-RERF05200	500	2000	550	525	105	170	130	178	7	74	140	C Tipi / C Type
1035-RERF07160	700	1600	750	725	105	170	130	158	9	74	140	C Tipi / C Type
1035-RERF07200	700	2000	750	725	105	170	130	178	9	74	140	C Tipi / C Type
1035-RERF08160	800	1600	850	825	105	170	130	178	10	74	140	C Tipi / C Type
1035-RERF08200	800	2000	850	825	105	170	130	188	10	74	140	C Tipi / C Type
1035-RERF09160	900	1600	950	925	105	170	130	218	11	74	140	C Tipi / C Type
1035-RERF09200	900	2000	950	925	105	170	130	248	11	74	140	C Tipi / C Type

Ürün Nr. 1035 Kalıp Kaydırma Kolu Model RE-RF

- İş bittiğinde sağa veya sola katlanabilir.
- RE ve RF Modellerinin kurulduğu mesafe (C) mesafesinden daha büyük olmalıdır.

Product Nr. 1035 Die Arm Model RE-RF

- Itself can be turned left or right for storage.
- The distance for installing the two arms of Model RE and RF should be more than the distance between the installations (C)

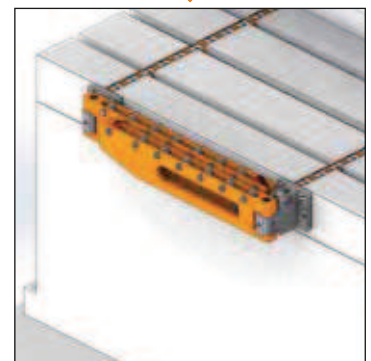
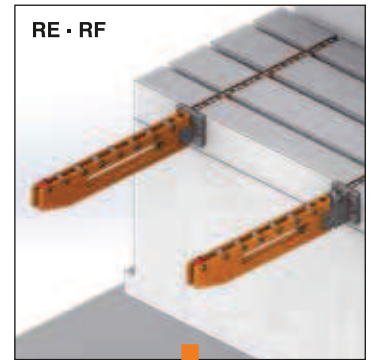
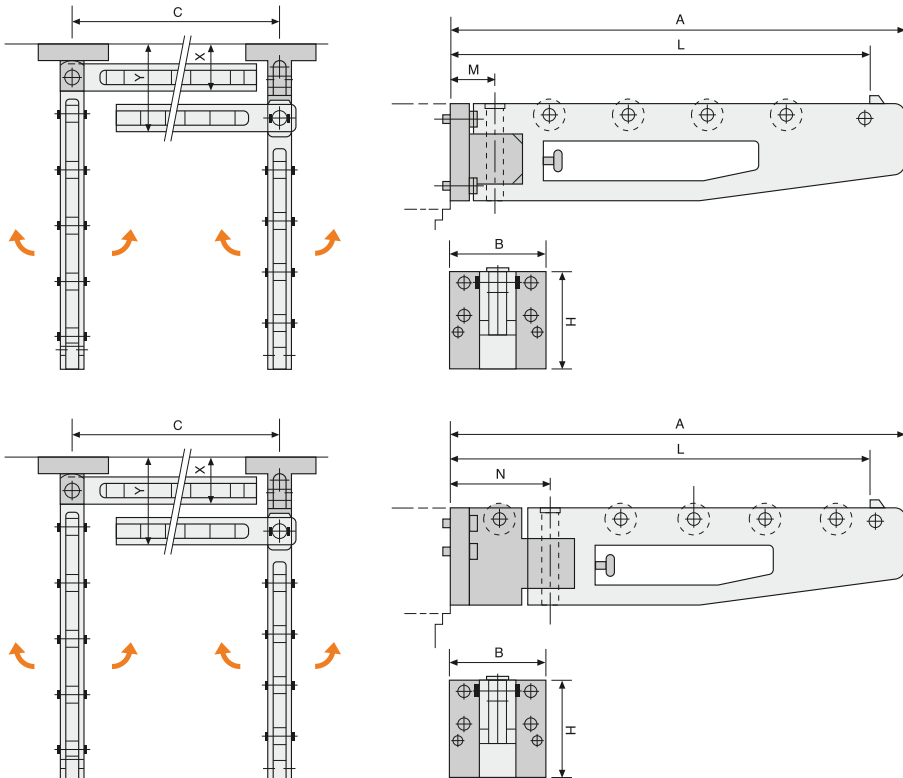

 Model RE
Katlamalı / Folding

 Model RF
Katlamalı / Folding

Model RS (Destek / Supporter)

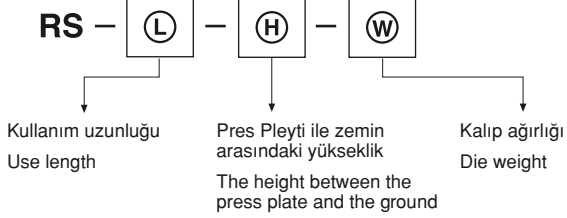

Model Seçimi / Model Selection



Ürün Nr. 1037 Kalıp Kaydırma Kolu Model RS Product Nr. 1037 Die Arm Model RS

- Sipariş verirken yukarıdaki bilgileri bildirmeniz gerekmektedir.
- Delik işleminde (D) tipi destek ölçülerini kullanın.
- Please clearly indicate the above information while ordering.
- Adopt (D) type to install hole pattern.

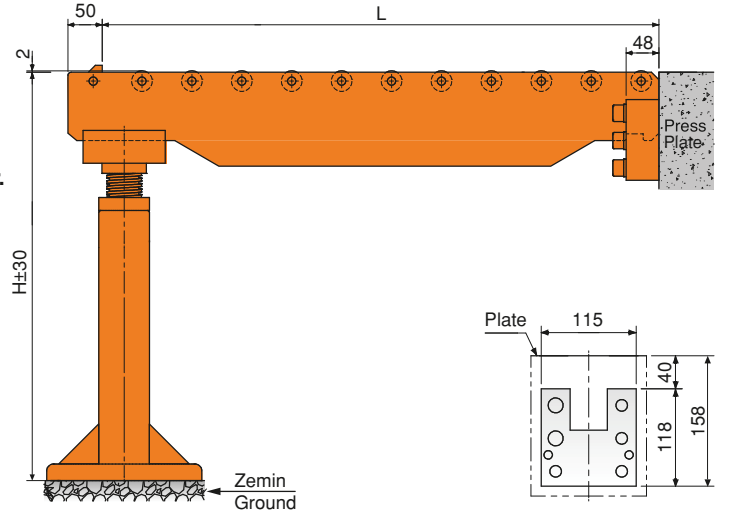

DELİK DELME ŞABLONLARI HOLE PATTERN FOR INSTALLATION

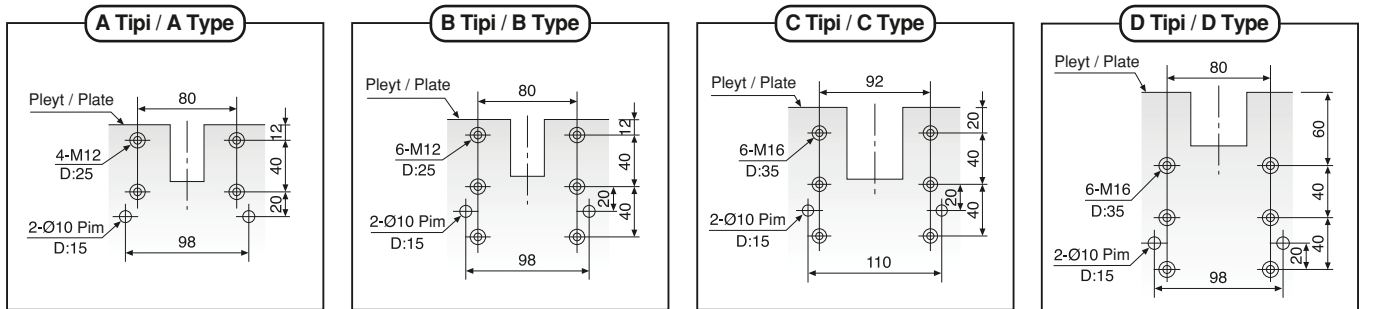

Aksesuarlar Accessories

Bağlayıcı Tüp / Tube Connector
Referans Nr. 1036

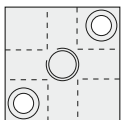

Döner Eklem
Rotary Joint
Referans Nr. 1037



Pabuç Askısı
Clamp Bracket
Model CA



Pabuç Askısı
Clamp Bracket
Model CB



Referans Nr.	L1	L2	H	 (kg)
1040-PB0801P1V	250	225	367	15.55
1040-PB0801P2V	310	285	367	18.55
1040-PB0801P3V	428	403	367	21.50
1040-PB0801P4V	487	462	367	24.70
1040-PC1201P3V	-	397	367	-



Ürün Nr. 1040 Hava Tahrikli Hidrolik Pompa Ünitesi

- Hidrolik Pompa hava tahriklidir. Hidrolik basınç ayarlanan seviyeye geldiğinde pompalamayı tasarruf etmek için keser. Diğer taraftan, çalışma basıncı azalırsa, pompa devamlılığı sağlamak için otomatik olarak basınç verir.
- Devre kontrol sistemi olası kaçakları denetleme ve engelleme fonksiyonuyla tasarlanmıştır. Pnömatik basınç devre dışı kalsa bile hidrolik basınç kalır.
- Basınç denetleme ve makinelere bağlanma özelliği vardır.
- CA ve CB-16 veya 25 bağlama pabuçlarıyla uygulama yapıldığında, PC12 model pompa kullanılması önerilir.
- Kapasite 400 max. Bar
- Basınç kontrol valfli

Product Nr. 1040 Air Driven Hydraulic Pump Unit

- The hydraulic pump is driven by air. Once the hydraulic pressure reaches the pressure setting, it stops pumping which is energy saving. Meanwhile, if the working pressure reduces, the pump would supply pressure automatically to keep working pressure continuously.
- The circuit control system is designed with the function of checking and avoiding oil leakage. If pneumatic pressure out, the hydraulic pressure still maintains.
- It is capable of pressure inspection and connecting to machines.
- It is suggested to adopt pump model PC12 when used with clamp model CA&CB-16 or 25.
- Capacity 400 max. bar
- Pressure control valve

Model Seçimi / Model Selection

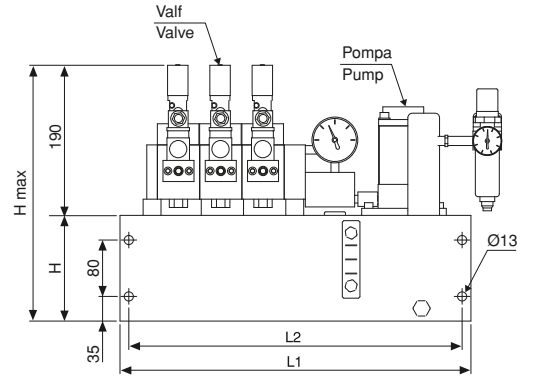
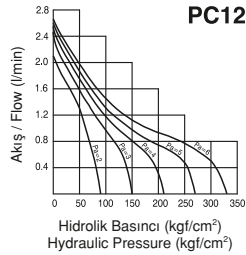
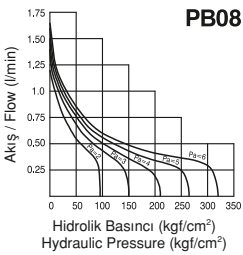
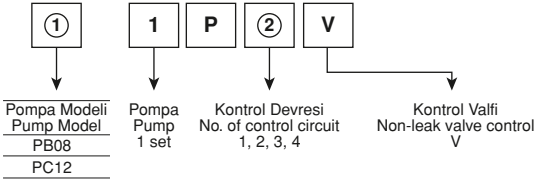

Referans Nr.
1040-PB0101

Ürün Nr. 1040 Hidrolik El Pompası

- Sadece kalıp kaldırma kullanıldığında alternatif olarak hidrolik el pompası kullanılabilir.
- 250 Bar

Product Nr. 1040 Hydraulic Hand Pump

- If only the die lifter is used, the usage of a manual hydraulic pump can alternatively be used.
- 250 Bar

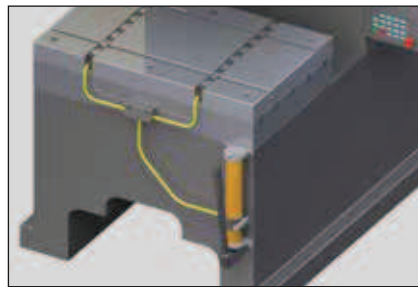

Alternatif Sistem
Alternative Systems

Hidrolik El Pompası

Hydraulic Hand Pump



Referans Nr.	Devreli Circuits
1041-QDC01	1
1041-QDC02	2
1041-QDC03	3
1041-QDC04	4

Ürün Nr. 1041 Kontrol Ünitesi

Product Nr. 1041 Control Unit

Kontrol Ünitesi

Control Unit





Referans Nr.	Valf Valve	Akış - Flow		bar
		(l/min)	(l/min)	
1040-1P1VD	1	6	14	150
1040-1P2VD	2	6	14	150
1040-1P3VD	3	6	14	150
1040-1P4VD	4	6	14	150

Ürün Nr. 1040 Elektrikli Hidrolik Pompa Ünitesi

- Doğrudan bağlantı sistemine uygundur.
- Satın almadan önce (l/dk.) akış hızını belirtiniz.

Product Nr. 1040 Electric Hydraulic Pump Unit

- It is suitable for direct connection system.
- Please, you specify about flow speed (l/minute) before make purchase.

Referans Nr.	Valf Valve	Akış - Flow		bar
		(l/min)	(l/min)	
1040-1P1V	1	6	14	150
1040-1P2V	2	6	14	150
1040-1P3V	3	6	14	150
1040-1P4V	4	6	14	150

Ürün Nr. 1040 Elektrikli Hidrolik Pompa Ünitesi

- Jaklı sisteme uygundur.
- Satın almadan önce (l/dk.) akış hızını belirtiniz.

Product Nr. 1040 Electric Hydraulic Pump Unit

- It is suitable for quick coupling.
- Please, you specify about flow speed (l/minute) before make purchase.

Elektrikli Hidrolik Pompa Ünitesi

Referans Nr.
1042-02

Ürün Nr. 1042 Modüler Quick Coupling**Product Nr. 1042 Moduler Quick Coupling****Modüler Quick Coupling**