

HİDROLİK KOMPONENTLER

HYDRAULIC COMPONENTS



Uygulama

Bir işparçası takım ile işlenirken, işparçasının operatör tarafından yerleştirilmesi - alınmasına olanak yoksa ve daha yüksek bağlama kuvvetine ihtiyaç duyuyorsa, hidrolik dönmeli bağlama silindiri en iyi seçim olacaktır.

Fonksiyon

Bu silindir çekme özelliğine sahiptir. Toplam bağlama stroku, dönme ve çekme strokuna eşittir.

Tip

Bu silindir aşağı doğru baskı yapar. Saat yönüne ve ters istikametine çift hareketli çeşidi vardır. Standart 90° olup, fonksiyonel 0°-45° ve 60° açılara sahiptir. Bağlama şekline tek kol veya çift kol dahildir. Bağlama türüne dişli tip ve o-ring keçeli manifoldlu tipi için alttan flanşlı dahildir.

Malzeme

Ana gövdenin malzemesi alüminyum alaşımıdır.



Application

When machining a workpiece by means of a machine tool, a hydraulic swing clamping cylinder will be your best choice if the placing and taking of the workpiece are not allowed to be interfered by the clasper and need a larger clamping force.

Function

This cylinder belongs to a pull cylinder of which the total stroke is equal to the sum of a swing stroke and a clamping stroke, and is usually used within the clamping stroke.

Type

This swing cylinder belongs to a double-acting type which is operated mainly in a downward pressing manner, including clockwise swing and counterclockwise swing; standard angle is 90°, and optional angles include 0°, 45°, 60°; clamping means includes single arm or double arms; the mounting manner includes threaded type and lower flange type for manifold mounting with O-ring seal.

Material

This material of the main body is aluminum alloy.



Sipariş örneği / Ordering example

Referans Nr.

NHS

Temel No.
Base No.

T

Tip / Type
Flanş
Flange

T: Dişli
T: Threaded

D

Kol Tipi / Arm Type
D: Çift Hareket
D: Double Arm

Boş: Tek Hareket
Blank: Single Arm

L –

Dönüş İstikameti
Swivel Direction
L: Sol
L: Left

R: Sağ
R: Right

40

Piston Ø
25
32
40
50
63

x 90° –

Açı / Angle
0°
45°
60°
90°
180°

Değişik hidrolik basınçlar altında teorik bağlama gücünü gösteren şematik tablolar

Schematic view showing a theoretical clamping force under different hydraulic pressure:

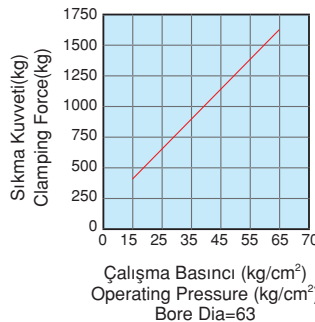
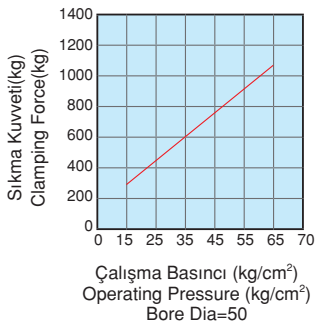
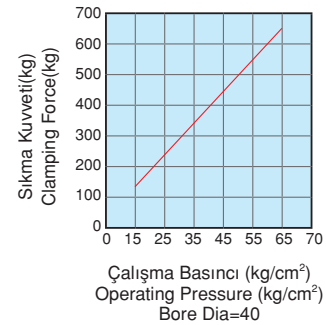
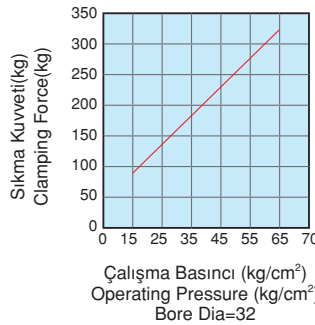
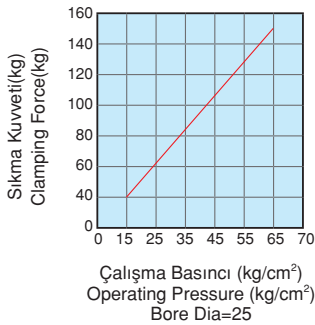

Referans Nr.	Bağlama Tipi Mounting Type	Bağlama Kolu Clamping Arm	Max. Basınç Max. Pressure	Normal Basınç Normal Pres.	Hareket Tipi Acting Type	Dönme Açısı Swivel Angle	Dönme Strok Swivel Stroke (mm)	Bağlama Strok Clamp. Str. (mm)	Delik Çapı / Bore Diameter Ø (mm)	Piston Çubuğu Piston Rod Ø	Bağl. Gücü/Clamp Force (25kg/cm ²)	A (mm) Sökme Unclamp	B (mm)	C (mm)	D (mm)	G (mm)	H (mm)	L1 Bağlama / Clamp L2 Sökme / Unclamp	N (mm)	P (mm)	Q (mm)	R (mm)	S (mm)	Çeşitli O-Ring Manifold O-Ring	M (mm)	F (mm)	Ağırlık Weight (kg)					
1043-NHS025	Flanş / Bottom Flange	Tek Kol / Single Arm	70 kg/cm ²	20-45 kg/cm ²	Çift Hareketli / Double Acting	90° (0° 45°, 60°, 180°) ± 2°	12	14	25	18	59	100	70	23	□	25.4	50	10	1/8 PF	M10 x1.5	40	50	Ø 6.5	Ø 45	S4	18	15	0.8				
1043-NHS032							14	15	32	20	125	111	76	25	□	25.4	55	10	□	25.4	55	10	1/8 PF	M10 x1.5	44	55	Ø 6.5	Ø 50	S4	24	17	1.0
1043-NHS040							14	15	40	20	200	113.6	80	27	□	25.4	55	10	□	25.4	55	10	1/8 PF	M10 x1.5	48	62	Ø 8.5	Ø 54	S4	26	20	1.1
1043-NHS050							14	15	50	20	400	114.5	80	27	□	25.4	55	10	□	25.4	55	10	1/8 PF	M10 x1.5	57	74	Ø 8.5	Ø 65	S4	30	25	1.4
1043-NHS063							14	15	63	25	600	118	85	32	□	32	75	11	□	32	75	11	1/8 PF	M12 x1.75	70	88	Ø 10.5	Ø 80	S4	40	30	2.3

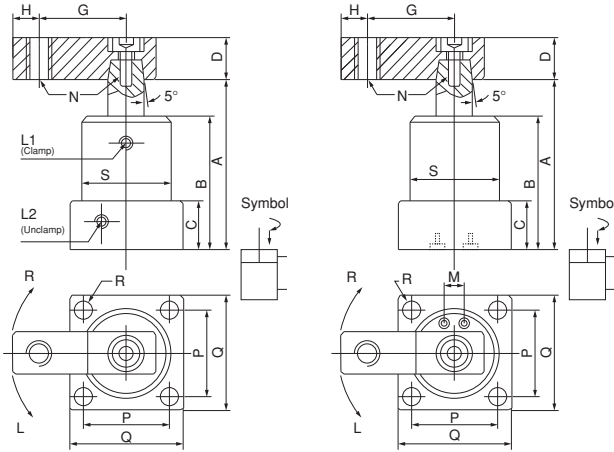

Ürün Nr. 1043 Hidrolik Dönmeli Bağlama Product Nr. 1043 Hydraulic Swing Clamp

NHS – Flanşlı Uyarlama, Tek Kol
Borulu veya Manifoldlu

NHS – Flange Version, Single Arm
With Pipe or the Manifold

- Satın almadan önce hareket tipini ve dönme açısını bildiriniz.
- Before buying please, movement indicate the type and rotation angle.



Hidrolik Dönmeli Bağlama

Hydraulic Swing Clamp

Referans Nr.	Bağlama Tipi Mounting Type	Bağlama Kolu Clamping Arm	Max. Basınç Max. Pressure	Normal Basınç Normal Pres.	Hareket Tipi Acting Type	Dönme Açısı Swivel Angle	Dönme Strok Swivel Stroke (mm)	Bağlama Strok Clamp. Str. (mm)	Delik Çapı / Bore Diameter Ø (mm)	Piston Çubuğu Piston Rod Ø	Bağl. Gücü/Clamp Force (25kg/cm ²)	A (mm) Sökme Unclamp	B (mm)	C (mm)	D (mm)	G (mm)	H (mm)	L1 Bağlama / Clamp L2 Sökme / Unclamp	N (mm)	P (mm)	Q (mm)	R (mm)	S (mm)	Çeşitli O-Ring Manifold O-Ring	M (mm)	F (mm)	Ağırlık Weight (kg)
1045-NHSD025	Flanş / Bottom Flange	Çift Kol / Double Arm	70 kg/cm ²	20-45 kg/cm ²	Çift Hareketli / Double Acting	90° (0° 45°, 60°, 180°) ± 2°	12	14	25	18	59	100	70	23	□	19	100	1/8 PF	Ø 8	40	50	Ø 6.5	Ø 45	S4	18	15	0.9
1045-NHSD032							14	15	32	20	125	111	76	25	□	22	120	1/8 PF	Ø 8	44	55	Ø 6.5	Ø 50	S4	24	17	1.1
1045-NHSD040							14	15	40	20	200	113.6	80	27	□	22	120	1/8 PF	Ø 8	48	62	Ø 8.5	Ø 54	S4	26	20	1.2
1045-NHSD050							14	15	50	20	400	114.5	80	27	□	22	120	1/8 PF	Ø 8	57	74	Ø 8.5	Ø 65	S4	30	25	1.5
1045-NHSD063							14	15	63	25	600	118	85	32	□	25.4	140	1/8 PF	Ø 10	70	88	Ø 10.5	Ø 80	S4	40	30	2.5

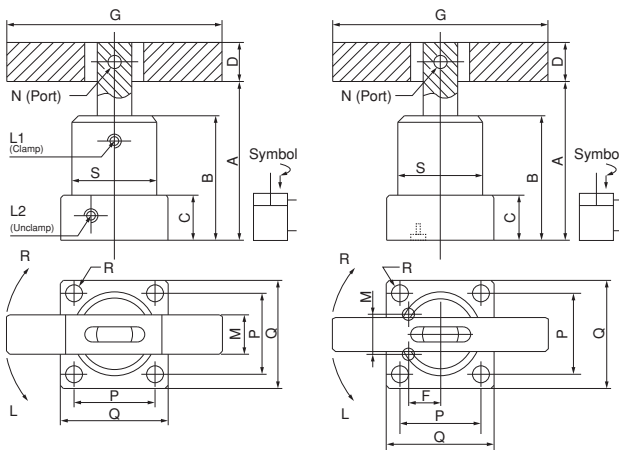

Ürün Nr. 1045 Hidrolik Dönmeli Bağlama Product Nr. 1045 Hydraulic Swing Clamp

NHSD – Flanşlı Uyarlama, Çift Kol
Borulu veya Manifoldlu

NHSD – Flange Version, Double Arms
With Pipe or the Manifold

- Satın almadan önce hareket tipini ve dönme açısını bildiriniz.
- Before buying please, movement indicate the type and rotation angle.



Referans Nr.	Bağlama Tipi Mounting Type	Bağlama Kolu Clamping Arm	Max. Basınç Max. Pressure	Normal Basınç Normal Pres.	Hareket Tipi Acting Type	Dönme Açısı Swivel Angle	Dönme Strok Swivel Stroke (mm)	Bağlama Strok Clamp. Str. (mm)	Delik Çapı / Bore Diameter Ø (mm)	Piston Çubuğu Piston Rod Ø	Bağl. Gücü/Clamp Force (25kg/cm ²)	A (mm) Sökme Unclamp	B (mm)	C (mm)	D (mm)	G (mm)	H (mm)	I (mm)	L1 Bağlama / Clamp L2 Sökme / Unclamp	N (mm)	S (mm)	T (mm) / Kona. Sm. 2.ad. T (mm) / 2 pcs/set	Y (mm)	Ağırlık Weight (kg)	
1047-NHTS025	Dişli Gövde / Threaded Body	Tel Kol / Single Arm	70 kg/cm ²	20-45 kg/cm ²	Çift Hareketli / Double Acting	90° (0°-45°, 60°, 180°) ± 2°	12	14	25	18	59	100	70	35	□	25.4	50	10	9	1/8 PF	M10 x1.5	M45 x1.5	Ø 65	10	0.8
1047-NHTS032							14	15	32	20	125	111	76	45	□	25.4	55	10	9	1/8 PF	M10 x1.5	M50 x1.5	Ø 70	11	1.1
1047-NHTS040							14	15	40	20	200	113.6	80	45	□	25.4	55	10	9	1/8 PF	M10 x1.5	M55 x1.5	Ø 75	11	1.25
1047-NHTS050							14	14	50	20	400	120	87	50	□	25.4	55	10	9	1/8 PF	M10 x1.5	M65 x1.5	Ø 85	12	1.7

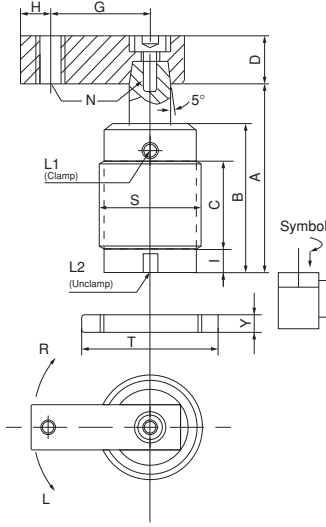

Ürün Nr. 1047 Hidrolik Dönmeli Bağlama Product Nr. 1047 Hydraulic Swing Clamp

NHTS – Dişli Uyarlama, Tek Kol
Borulu

NHTS – Threaded Version, Single Arm
With Pipe

- Satın almadan önce hareket tipini ve dönme açısını bildiriniz.
- Before buying please, movement indicate the type and rotation angle.



Hidrolik Dönmeli Bağlama

Hydraulic Swing Clamp

Referans Nr.	Bağlama Tipi Mounting Type	Bağlama Kolu Clamping Arm	Max. Basınç Max. Pressure	Normal Basınç Normal Pres.	Hareket Tipi Acting Type	Dönme Açısı Swivel Angle	Dönme Strok Swivel Stroke (mm)	Bağlama Strok Clamp. Str. (mm)	Delik Çapı / Bore Diameter Ø (mm)	Piston Çubuğu Piston Rod Ø	Bağl. Gücü/Clamp Force (25kg/cm ²)	A (mm) Sökme Unclamp	B (mm)	C (mm)	D (mm)	G (mm)	H (mm)	I (mm)	L1 Bağlama / Clamp L2 Sökme / Unclamp	N (mm)	S (mm)	T (mm) / Kona. Sm. 2.ad. T (mm) / 2 pcs/set	Y (mm)	Ağırlık Weight (kg)
1050-NHTSD-25	Dişli Gövde / Threaded Body	Çift Kol / Double Arm	70 kg/cm ²	20-45 kg/cm ²	Çift Hareketli / Double Acting	90° (0°-45°, 60°, 180°) ± 2°	12	14	25	18	59	100	70	35	□	100	9	1/8 PT	Ø 8	M45 x1.5	Ø 65	10	0.9	
1050-NHTSD-32							14	15	32	20	125	111	76	45	□	120	10	1/8 PT	Ø 8	M50 x1.5	Ø 70	11	1.2	
1050-NHTSD-40							14	15	40	20	200	113.6	80	45	□	120	10	1/8 PT	Ø 8	M55 x1.5	Ø 75	11	1.4	
1050-NHTSD-50							14	14	50	20	400	120	87	50	□	120	10	1/8 PT	Ø 8	M65 x1.5	Ø 85	12	1.85	

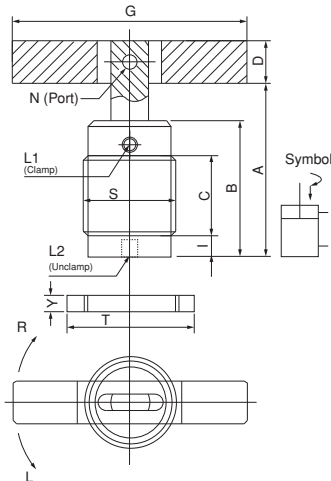

Ürün Nr. 1050 Hidrolik Dönmeli Bağlama Product Nr. 1050 Hydraulic Swing Clamp

NHTSD – Dişli Uyarlama, Çift Kol
Borulu

NHTSD – Threaded Version, Double Arms
With Pipe

- Satın almadan önce hareket tipini ve dönme açısını bildiriniz.
- Before buying please, movement indicate the type and rotation angle.



Referans Nr.	A (mm)	B (mm)	C (mm)	D (mm)	E (mm)	F (mm)	G (mm)	H (mm)	J (mm)	K (mm)	M (mm)	N (mm)	P (mm)	Q (mm)	R (mm)	T (mm)	Z (mm)	A1 (mm)	L1 (mm)	N1 (mm)	(kg)
1051-VS035	129	61	51	48	80	52	28	35.5	25.5	40	12	30	3	9.5	5.5	16	22	65.5	42	M6	0.84
1051-VS042	146	69	60	55	87	59	28	39	30	47	12	33.5	3	11	6.5	18.5	24	77	50	M8	1.25
1051-VS050	153	81	70	65	93	63	30	46	35	55	13	39.5	5	11	6.5	20	30	91.5	56.5	M10	1.86
1051-VS060	179	92	80	75	108	71	37	52	40	63	16	45	5	14	8.5	23.5	32	105	65	M12	2.86
1051-VS074	192	107	95	90	114	74	40	59.5	47.5	75	16	52.5	5	17.5	10.5	25	37	127	75	M16	4.75

Referans Nr.	Silindir Alan cm ² Cylinder Area cm ²	Toplam Strok Total Stroke	Sıkma Strok Clamp Stroke	Dönme Strok Swivel Stroke	Silindir Hacmi cm ³ /Sıkma Cylinder Volume cm ³ /Clamp	Silindir Hacmi cm ³ /Boşta Cylinder Volume cm ³ /Release	Maximum Çalışma Basıncı 70 kg/cm ² Clamping Force at 70 kg/cm ²	Min./Max. Çalışma Basıncı kg/cm ² Min./Max. Operating Pressure kg/cm ²	Çalışma Sıcaklığı Operating Temperature	90° Dönme Açılı Toleransı 90° Swing Angle Tolerance	Sıkma Salıncak Pozisyon Tekrarı Clamp-Swing Position Repeat Tolerance
1051-VS035	5.8	22	8	14	12.8	21.2	405	5 - 70	0-70°	90±2°	0.5°
1051-VS042	8.9	25	10	15	22.4	34.6	625	5 - 70	0-70°	90±2°	0.5°
1051-VS050	12.6	26	10	16	32.7	51.0	880	5 - 70	0-70°	90±2°	0.5°
1051-VS060	18.4	29	12	17	53.3	82.0	1285	5 - 70	0-70°	90±2°	0.5°
1051-VS074	27.1	30	12	18	81.3	129.0	1896	5 - 70	0-70°	90±2°	0.5°

Ürün Nr. 1051 Hidrolik Dönmeli Bağlama

Product Nr. 1051 Hydraulic Rotary Linking

Borulu ve Manifodlu With Pipe and the Manifold

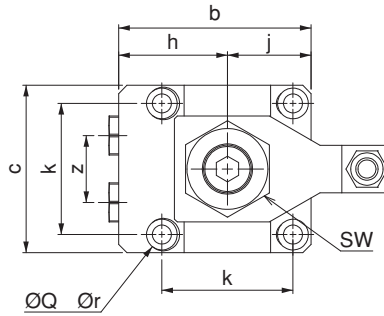
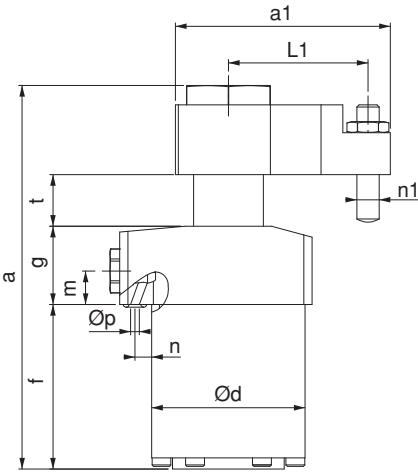

Referans Nr.	A	B	C	E	F	G
1051-VS035	40	M5	48	30	22	3
1051-VS042	47	M6	55	33.5	24	3
1051-VS050	55	M6	65	39.5	30	5
1051-VS060	63	M8	75	45	32	5
1051-VS074	75	M10	90	52.5	37	5

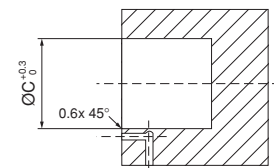
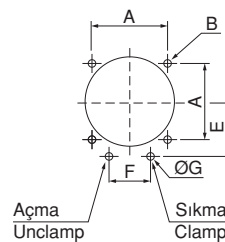

Referans Nr.	Toplam Tork Total Stroke (mm)	Sıkma Torku Lock Stroke (mm)	Ekstra Tork Extra Stroke (mm)	Max. Basınç Max. operating pressure kg/cm	Min. Basınç Min. operating pressure kg/cm	Sıkma Kuvveti Clamping Force (at 25 kg/cm ²)	Çalışma Isısı Operating Temperature	 (kg)
1052-VT25S	23.5	20.5	3	70	20	100kg	0 - 70°C	0.60
1052-VT32S	26	23	3	70	20	160kg	0 - 70°C	0.92
1052-VT40S	29.5	26.5	3	70	20	250kg	0 - 70°C	1.86
1052-VT50S	35	32	3	70	20	390kg	0 - 70°C	2.34
1052-VT63S*	41	38	3	70	20	620kg	0 - 70°C	3.90



Ürün Nr. 1052 Hidrolik Üstten Bağlama

• 1052-VT63S kodlu ürün manifoldlu ve yağ giriş, yağ dönüşlüdür.

Product Nr. 1052 Hydraulic Above Clamp

• 1052-VT63S coded products manifold and oil flow, oil is reflexive.

Borulu ve Manifoldlu
With Pipe and the Manifold

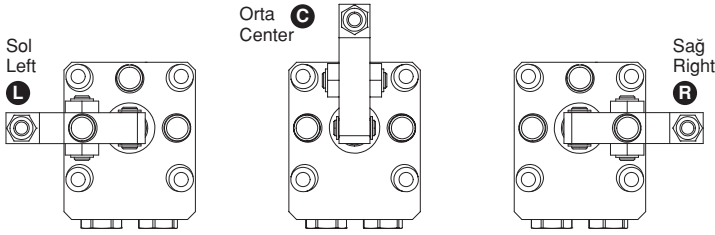

Referans Nr.	A	B	C	E	F	G
1052-VT25S	40	M5x0.8	48	30	11	3
1052-VT32S	47	M6	55	33.5	12	3
1052-VT40S	55	M6	65	39.5	15	5
1052-VT50S	63	M8	75	45	16	5
1052-VT63S	75	M10	90	52.5	18.5	5

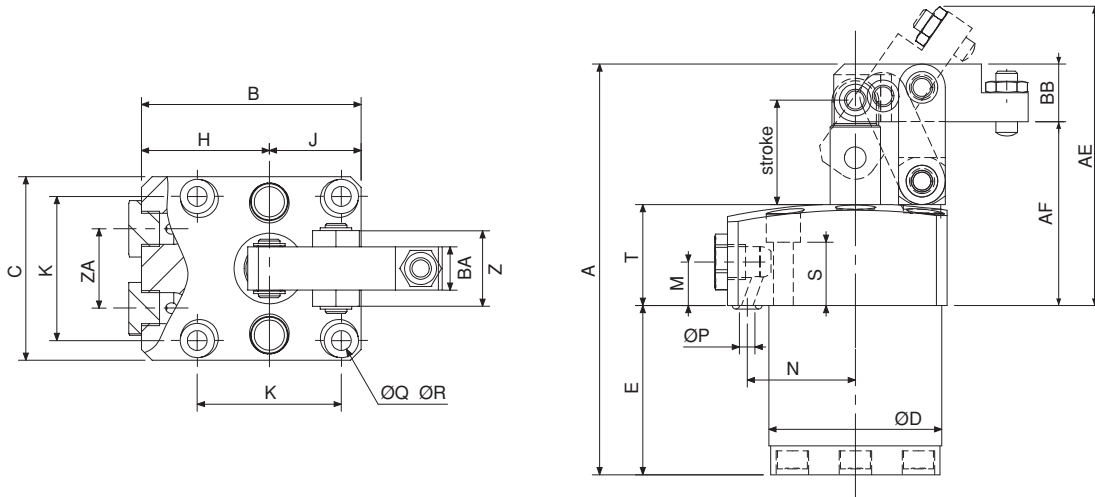
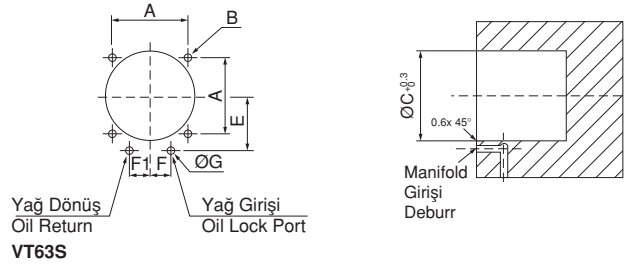

Referans Nr.	A	B	C	D	E	F	G	H	J	K	M	N	P	Q	R	S	T	U	V	W	X	Y	Z	part	ZA	Bağlama Pabucu Clamping Arm				Q	R
																										AE	AF	BA	BB		
1052-VT25S	114	61	51	48	75	47	28	35.5	25.5	40	12	30	3	9.5	5.5	17.5	35	14	29	34.5	26	13	21	G1/8	22	92.4	51	12	16	9.5	5.5
1052-VT32S	132.5	69	60	55	87	59	28	39	30	47	12	33.5	3	11	6.8	15	37.5	16	31.5	35.5	30	16	28	G1/8	24	101.9	53.5	16	20	11	6.8
1052-VT40S	147	81	70	65	93	63	30	46	35	55	13	39.5	5	11	6.8	15.5	45	18	37	39	35.5	19	37	G1/4	30	111.4	59	19	25	11	6.8
1052-VT50S	175	94.5	85	75	108	71	37	52	42.5	63	16	45	5	14	9	19.5	55	22	45	48	43.5	25	40	G1/4	32	130.8	72	22	32	14	9
1052-VT63S	207	109.5	100	90	128	88	40	59.5	50	75	16	52.5	5	17.5	11	19	64.5	28	52	52.5	52.5	28	49	G3/8	37	146.5	81	25	38	17.5	11

Açıklama

Bu dişli-gövde bağlama silindiri itme koşullu ve iş parçasını güvenle bağlamak için belirli bir strok aralığında çalışır. Dişli gövde bağlama silindirinin montaj şekli, önerilen ölçülerde aşağıdaki çizimde belirtilmiştir. Bu montaj da yağ sızıntısını önlemek için teflon pul kullanılır.

Description

This threaded-body clamping cylinder is applied to a condition of knocking-out, and applies a clamping force on a workpiece within a stroke in order to secure the workpiece. The mounting manner for this threaded-body clamping cylinder is shown as the following drawing illustrating suggested dimensions of devices, and this mounting needs a Teflon packing in order to avoid oil leakage.

Sipariş Örneği / Ordering example

Nr. 1053 **TC** **12** **A**
 Temel No. Piston Ø Seri / Series
 Base No.

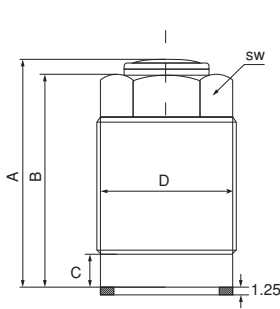

A Tipi / A Type

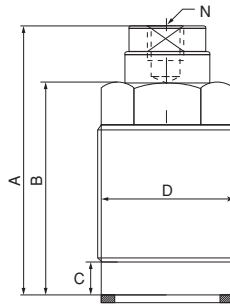

B Tipi / B Type

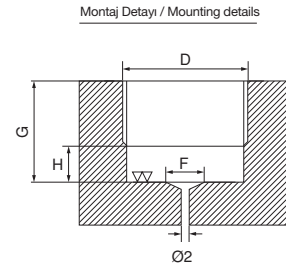

Bağlama Diyagramı
Mounting Diagram

Referans Nr.	Çalışma Yağı Basıncı Operating Oil Pressure	Hareket Tipi Acting Type	Strok Stroke S (mm)	Piston Çubuğu Piston Rod Ø (mm)	Bağl. Gücü/Clamp Force (200kg/cm ²)	A (mm)	B (mm)	C (mm)	D (mm)	F (mm)	G (mm)	H (mm)	N (mm)	SW	Ağırlık Weight (kg)
1053-TC12A	20-350 kg/cm ²	Tek Hareketli / Single Acting	10	12	200 (kg)	38	36	7	M22 x1.5	12	16	6	-	17	0.07
1053-TC16A			12	16	400 (kg)	46.5	44.5	8	M26 x1.5	16	20	7	-	22	0.14
1053-TC-20A			15	20	620 (kg)	56	54	8	M30 x1.5	20	24	7	-	24	0.22
1053-TC25A			16	25	980 (kg)	57	55	11	M38 x1.5	25	28	10	-	32	0.37
1053-TC12B			10	12	200 (kg)	45	36	7	M22 x1.5	12	16	6	M6x1	17	0.08
1053-TC16B			12	16	400 (kg)	52	44.5	8	M26 x1.5	16	20	7	M6x1	22	0.15
1053-TC20B			15	20	620 (kg)	64.5	54	8	M30 x1.5	20	24	7	M8x1.25	24	0.24
1053-TC25B			16	25	980 (kg)	67	55	11	M38 x1.5	25	28	10	M8x1.25	32	0.4

Referans Nr.	Strok Stroke (mm)		Silindir Forsu(kN) / Cylinder Force(kN)				Silindir iç çap (mm) Cyl. inner dia. (mm)	Çubuç Çapı (mm) Rod dia. (mm)	Etkil Alan (cm ²) Effec. area(cm ²)	Max. Yağ akış alanı (l/min) Max. oil flow rate(l/min)	Silindir kapa. (cm ³) Cylinder cap.(cm ³)		Yay geri çekiş gücü (N) Return spring force (N)	Sıkma Kuvveti Clamp Force (20kg/cm2)
			Hidrolik Basınç Hydraulic Press. 3.5 MPa	Hidrolik Basınç Hydraulic Press. 7 MPa	Hidrolik Basınç Hydraulic Press. 25 MPa	Hidrolik Basınç Hydraulic Press. 35 MPa								
1055-CMD02	5	10	0.3	0.5	2.1	2.9	16	10	0.84	0.25	0.5	0.9	30~56	245
1055-CMD04	5	10	0.4	0.9	3.4	4.8	18	10	1.37	0.41	0.7	1.4	43~77	351
1055-CMD06	10	20	0.7	1.5	5.6	7.9	22	12	2.29	0.69	2.3	4.6	65~120	533
1055-CMD10	10	20	1.2	2.5	9.3	13	28	16	3.76	1.13	3.8	7.5	100~193	828
1055-CMD20	10	20	2	4.3	15.8	22.2	36	20	6.40	1.92	6.4	12.8	170~267	1400

Ürün Nr. 1055 Hidrolik Çekme Dişli Silindir

Product Nr. 1055 Hydraulic Pull Cylinder

Sipariş Örneği
Ordering example

Nr. 1055

CMD

02

Seri / Series

16

Piston Ø

5

Strok / Stroke



Teknik Ölçüler / Technical Dimensions

	Strok (mm) Stroke		B	C	D	E	F	G	(vassılar arasında sv geniş.) (hex width across flats)		(Üç kısım dişli) (tip section thread)		P	Q	R	S	T	(Hidrolik bağlantı girişi) (hydraulic connection port)		V	W	X	Y	O-ring Z	O-ring ZZ		
									sw	M1	M2	U															
CMD02	5	10	10	20.3	51	65	10	15	7.5	27	36	17	M6×1 depth 11	M22 ×1.5	6.5	20.5	13	32.5	41.5	5.5	3	5	7	4	3	P6	AS568-017
CMD04	5	10	10	23.3	51	65	10	15	8	26.5	35.5	19	M6×1 depth 11	M25 ×1.5	6.5	23.5	14	32	41	5.5	3	5	7.5	4	3	P6	AS568-019
CMD06	10	20	12	28.3	69	96	16	26	9.5	35.5	52.5	24	M8×1.25 depth 18	M30 ×1.5	8	28.5	15	42.5	59.5	7	3	5	9.5	4	3	P6	AS568-022
CMD10	10	20	16	34.3	73	101	17	27	11.5	35.5	53.5	30	M10×1.5 depth 20	M36 ×1.5	9	34.5	17	43.5	61.5	8	4	5	12	4	3	P6	AS568-026
CMD20	10	20	20	46.3	80	109	19	29	13.5	35.5	54.5	41	M12×1.75 depth 22	M48 ×1.5	12	46.5	20	46.5	65.5	11	6	7	15	4	3	P8	AS568-031

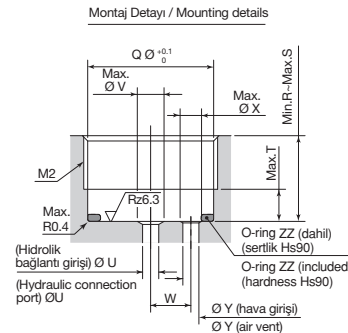
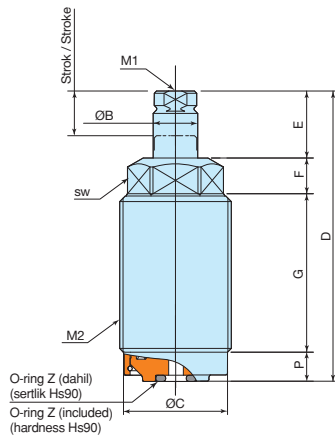

Referans Nr.	Kuvvet Desteği: 70kg/ cm ² Supporting Force	Strok Stroke	Max. Basınç Max. Pressure	Normal Basınç Normal Pressure	Temas Kuvveti Contact force	A	B	C	D	E	F	G	H	I	J	K	M	N	O	P	Q	R	S	CA	CB	CC	Ağırlık Weight (kg)	
1056-WST26BL	200 kg	6	105 kg / cm ²	25 - 70 kg / cm ²	0.67	66	48	6.5	9	5	4	24	9	10	-	-	-	M6 x9D	-	24	26	10	M26 x1	M26 x1	20-30	2	0.20	
1056-WST30BL	300 kg	8			0.96	73	53	9.5	9	7	4	4	27	8	10	-	-	-	M6 x9D	-	28	30	10	M30 x1.5	M26 x1.5	20-50	9	0.25
1056-WST36BL	360 kg	8			2.12	69	50	9.5	8	7	4	4	32	11	10	-	-	-	M8 x11D	-	34.2	36	13	M36 x1.5	M26 x1.5	20-48	8	0.35
1056-WSU40BL	360 kg	8			1.82	67	31	25	14.5	7	4	-	11	12	22.5	31.5	5.5	M10 x8	26	34	45	13	Ø40	Ø40	-	-	0.60	
1056-WSU48BL	720 kg	10			2.16	75	39	23	13.5	9	4	-	12	11	25.5	35.5	5.5	M10 x8	30	40	51	14	Ø48	Ø48	-	-	0.80	
1056-WSU55BL	840 kg	12			1.33	85	45	23	11.5	11	6	-	15	14	30.5	39	6.8	M10 x10	33.5	47	60	18	Ø55	Ø55	-	-	1.40	
1056-WSU65BL	1200 kg	14			1.05	101	56	27	14.5	12	6	-	17	14	35	46	6.8	M10 x10	40.5	55	70	20	Ø55	Ø55	-	-	2.20	

Ürün Nr. 1056 Hidrolik İş Parçası Desteği

Product Nr. 1056 Hydraulic Work Support

İş Parçası Desteği

- Hidrolik basınç aralığı 25-70 kg/cm², borulu ve manifoldlu montaj seçeneği vardır.
- Giriş ağızı küçük olduğundan dolayı pistonun yükselme hızını azaltır, iş parçasına olan temasının çok ve toleransını azaltır.

Önemli Notlar

- Hidrolik yağın saflığı: İş parçası desteğinin iç parçaları hassas olduğundan ve ürünün ömrünü etkileyeceğinden hidrolik yağın saflığı çok önemlidir, kötü yağ kullanımı destek kuvvetini etkiler.
- Silindir gövdenin temizlenmesi: Her işlemten sonra hava tabancasıyla temizleyiniz.
- Lütfen iş parçası desteğinin deformasyona uğramaması için aşağıdaki konulara dikkat ediniz.
 - A:** Piston milini üzerine, merkezi kaçık kuvvet uygulamayınız.
 - B:** Belirtilen kuvvet desteği üzerinde güç uygulamayınız.
 - C:** Piston kilitlendikten sonra çevirme işlemi yapmayınız.



Work Support Low Pressure

- The operating range is 25-70 kg/cm², the mounting type includes thread body and upper flange, and we have piping mounting and manifold mounting in upper flange type.
- Inlet orifice is smaller, so it can reduce the speed of plunger when it is rising, it can reduce the impact onto workpiece, and reduce the tolerance which is caused by instant shock.

The important issue when you use work support

- The purity of hydraulic oil: the inner parts installed in work support are very precise, so the purity of hydraulic oil becomes a very important issue which can affect the life cycle of work support, bad quality of oil will cause to lose its supporting force. In usual, the work support will work well again after we clean the hydraulic oil, for few conditions, we need to disassemble the work support and clean the inner parts, even we need to replace oil seal.
- Clean the cylinder body: the metal impurity is possible going into the collet during the action, please make sure to clean by using an air gun after each machining.
- Please avoid the following condition, otherwise the collet will be deformed, and plunger will not work, or will lose supporting force.

- A:** Apply eccentric force onto plunger.
- B:** Apply an load which exceeds the estimated supporting force.
- C:** To turn the plunger when it is locked at supporting position

Montaj Detayı / Mounting Details

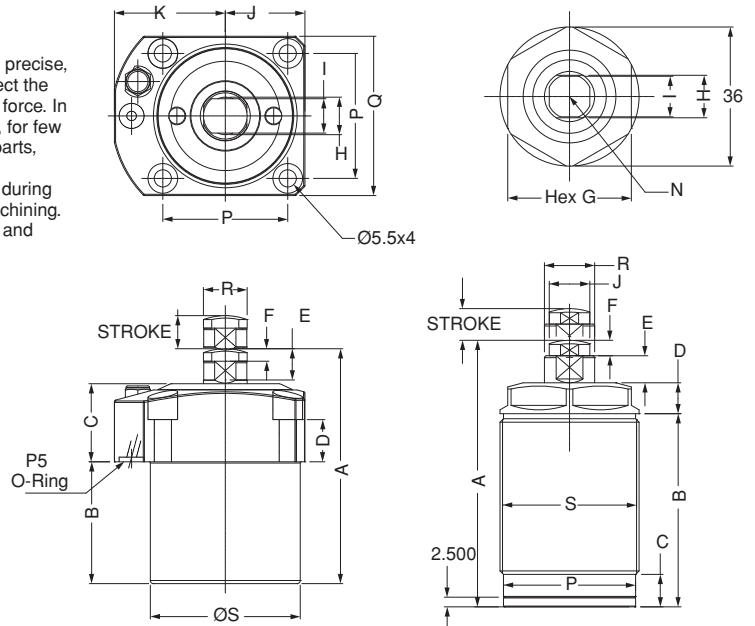
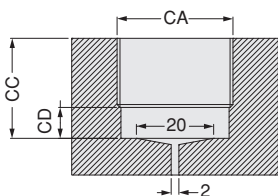

Referans Nr.	Çalışma Örneği / Advane Method	Kuvvet Desteği / 20 Mpa Supporting Force	Strok / Stroke	Max. Basınç / Max. Pressure	Min. Basınç / Min. Pressure	Normal Basınç / Normal Pressure	Çalışma Isısı / Operating Temperature	Temas Kuvveti / kg Contact force	A	B	C	C1	D	D1	D2	E	F	H1	H2	K	L	Q	U1	U2	O (O-ring)	Port	Ağırlık / Weight (kg)			
1056-WS16A	Yay Spring	600 kgf	8	35 Mpa	5 Mpa	21 Mpa	0° ~ +70°	-	85.1	75.4	64.5	23.9	M35 x1.5	38.1	60.5	16	12.4	11.2	7.6	M10 x1.5	4.5	-	41.1	23.9	-	-	0.60			
1056-WS16B	Hidrolik Hydraulic	600 kgf	8					2.35	99.3	89.7	78.7	27.4	M35 x1.5	38.1	60.5	16	12.4	14.2	17.8	M10 x1.5	4.5	-	41.1	23.9	-	-	-	-	-	0.60
1056-WS30A	Yay Spring	800 kgf	13					-	105	92	83	25	M60 x1.5	64	64	25	19	12.5	-	M10 x1.5	-	-	52	52	P7	G1/8	1.80			
1056-WS25B	Hidrolik Hydraulic	800 kgf	10.4					6.25	102.1	91.7	77.5	26.5	M50 x1.5	64	64	25	19	14	17.5	M16 x2	6	24.5	50	50	P7	G1/8	1.80			
1056-WS38A	Yay Spring	1200 kgf	10.4					-	96.5	86.1	74.9	24.9	M68 x1.5	69.9	82.6	39	25.4	12.2	10.2	M20 x2.5	6.1	27.4	55.4	55.4	P10	G1/8	2.20			
1056-WS38B	Hidrolik Hydraulic	1200 kgf	10.4					8.86	102.1	91.7	78	26.4	M68 x1.5	69.9	82.6	38	25.4	13.2	13.2	M20 x2.5	6.1	27.4	55.4	55.4	P10	G1/8	2.20			

Ürün Nr. 1056 Hidrolik İş Parçası Desteği

Açıklama

İş parçası desteği işlem esnasında vibrasyonu düşürmek ve deformasyonu engellemek için kullanılır.

Türleri

A tipi : Yayla itme; Piston milini en yüksek pozisyondayken iş parçası pozisyonu ayarlanır.

B tipi : Yağ basıncıyla itme; Piston milini en alçak pozisyonda iken iş parçası pozisyonu ayarlanır.

Product Nr. 1056 Hydraulic Work Support

Description

Hydraulic work support is used for avoiding deformation and decreasing vibration during machining.

Types

A type : knocking-out with a spring; the spring is used to control a contact force when the knocking out rod (piston rod) extends to a highest knocking-out position and contacts the workpiece.

B type : Knocking-out with oil pressure; when the knocking-out rod is at lowest position, it is operated by means of oil pressure and is knocked out when being filled with oil and uses a spring to control the contact force with the workpiece.

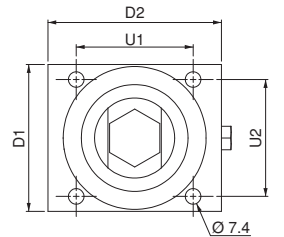
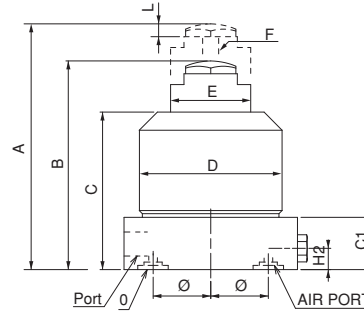
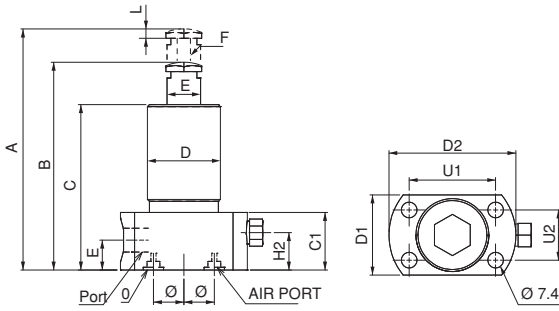

Referans Nr.	Çalışma Yağ Basıncı / Operating Oil Pressure	Hareket Tipi / Acting Type	Strok / Stroke	Piston Çubuğu / Piston Rod Ø (mm)	Kuvvet Desteği / 200kg / cm ² Supporting Force	Temas Kuvveti / kg Contact force	A	B	C	D	E	F	Ağırlık / Weight (kg)
1056-SP16A	100-350 kg/cm ²	Yaylı Spring	8	16	210 kg	-	79	54	8	M30 x1.5	11	8	0.30
1056-SP16B	100-350 kg/cm ²	Hidrolik Hydraulic	8	16	210 kg	2.35	72	54	8	M30 x1.5	11	8	0.30

Hidrolik İş Parçası Desteği

Hydraulic Work Support



SP16A

SP16B

Ürün Nr. 1056 Hidrolik İş Parçası Desteği

Product Nr. 1056 Hydraulic Work Support

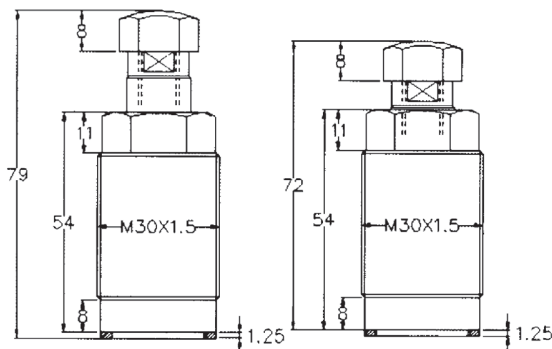

Montaj Detayı / Mounting details

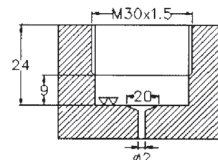

Referans Nr.	Temp. up to	Piston Ø D (mm)	Rod Ø d (mm)	Force to pull at 100 bar (kgf)	Force to pull at 500 bar (kgf)	Spring return force, min. (N)	Oil volume per 10 mm stroke (cm ³)	a (mm)	b (mm)	c (mm)	f (mm)	g (mm)	h (mm)	k (mm)	m (mm)	n (mm)	o	p	r (mm)	s (mm)	t (mm)	SW (mm)	Strok ± 1 (mm)	l ± 1 (mm)	Ağırlık Weight (kg)
1057-010016	100 °C	16	10	110	600	40	1.22	60	35	22	30	6.5	30	17.5	16.5	11	M6x12	G1/4	-	40	22	8	8	78	0.8
1057-015016	150 °C																								
1057-010025	100 °C	25	16	270	1430	140	2.90	65	45	27	50	8.5	33	22.5	18	11	M10x15	G1/4	-	50	30	13	8	91	1.2
1057-015025	150 °C																								
1057-010032	100 °C	32	20	460	2420	195	4.90	75	55	35	55	10.5	38	27.5	22	11	M12x15	G1/4	-	55	35	17	10	110	1.8
1057-015032	150 °C																								
1057-010040	100 °C	40	25	730	3790	270	7.65	85	63	35	63	10.5	40	31.5	24	11	M16x25	G1/4	4	63	40	-	10	114	2.6
1057-015040	150 °C																								
1057-010050	100 °C	50	32	1100	5730	440	11.60	100	75	35	76	13	44	37.5	27	13	M20x25	G1/4	4	76	45	-	12	125	3.8
1057-015050	150 °C																								
1057-010063	100 °C	63	40	1790	9230	430	18.60	125	95	44	95	17	50	47.5	26	17	M27x40	G1/2	4	95	65	-	12	146	6.7
1057-015063	150 °C																								
1057-010080	100 °C	80	50	2920	15180	760	30.63	160	120	46	120	21	60	60	34	21	M30x40	G1/2	5	120	80	-	12	193	12.8
1057-015080	150 °C																								
1057-100100	100 °C	100	63	4560	23500	1200	47.36	200	150	55	158	25	64	75	35	25	M42x60	G1/2	6	158	108	-	12	185	24
1057-150100	150 °C																								

Ürün Nr. 1057 Çekme Tipi Silindir

Product Nr. 1057 Pull-Type Cylinder

- Uzunluk ve açı ölçüleri DIN 7168-m'ye göre.
- Tolerances for length and angle dimensions as per DIN 7168-m

Önemli Notlar

Eğer sinterli metalin hava filtresinden silindirin içine, agresif talaş kaldırmadan dolayı, yağ veya soğutma suyu girme olasılığı var ise, bir hava deliği hortumu bağlanıp korunaklı bir pozisyona yerleştirilmeli.

Important notes

If there is a possibility that aggressive cutting lubricants and coolants penetrate through the sintered metal air filter into the cylinder's interior, a vent hose has to be connected and be placed in a protected position.

250 barı aşan çalışma basınçlarında silindirelir önden destekli olmalıdır.

Cylinders must be supported at the front for operating pressures exceeding 250 bar

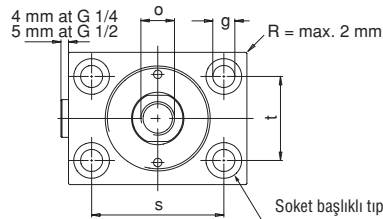
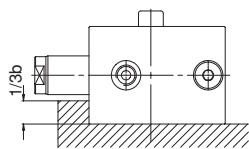

Soket başlıklı tıpa civatası için karşı delik DIN 912
Counterbore for socket head cap screw DIN 912

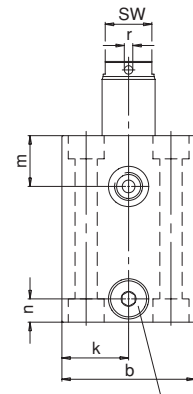
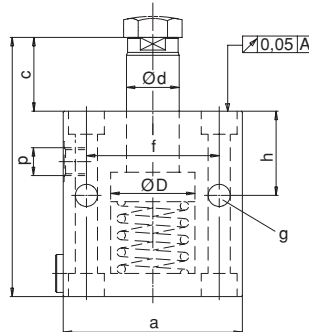

Sinter metalden hava filtreli soket yeri
Bleeding by plug with sintered metal air filter

Uygulama

Bir işparçası takım ile işlenirken, işparçasının operatör tarafından yerleştirilmesi - alınmasına olanak yoksa ve daha yüksek bağlama kuvvetine ihtiyaç duyuyorsa, pnömatik dönmeli bağlama silindiri en iyi seçim olacaktır.

Fonksiyon

Bu silindir çekme özelliğine sahiptir. Toplam bağlama stroku, dönme ve çekme strotuna eşittir.

Tip

Bu silindir aşağı doğru baskı yapar. Saat yönüne ve ters istikametine çift hareketli çeşidi vardır. Standart 90° olup, fonksiyonel 0°-45° ve 60° açılara sahiptir. Bağlama şekline tek kol veya çift kol dahildir. Bağlama türüne dişli tip ve o-ring keçeli manifoldlu tipi için alttan flanşlı dahildir.

Malzeme

Ana gövdenin malzemesi alüminyum alaşımıdır.



Application

When machining a workpiece by means of a machine tool, a pneumatic swing clamping cylinder will be your best choice if the placing and taking of the workpiece are not allowed to be interfered by the clammer and need a larger clamping force.

Function

This cylinder belongs to a pull cylinder of which the total stroke is equal to the sum of a swing stroke and a clamping stroke, and is usually used within the clamping stroke.

Type

This swing cylinder belongs to a double-acting type which is operated mainly in a downward pressing manner, including clockwise swing and counterclockwise swing; standard angle is 90°, and optional angles include 0°, 45°, 60°; clamping means includes single arm or double arms; the mounting manner includes threaded type and lower flange type for manifold mounting with O-ring seal.

Material

This material of the main body is aluminum alloy.



Sipariş örneği / Ordering example

Referans Nr.	NAS Temel No. Base No.	T Tip / Type Flanş Flange T: Dişli T: Threaded	D Kol Tipi / Arm Type D: Çift Hareket D: Double Arm Boş: Tek Hareket Blank: Single Arm	L – Dönüş İstikameti Swivel Direction L: Sol L: Left R: Sağ R: Right	40 Piston Ø 25 32 40 50 63	x 90° – Açı / Angle 0° 45° 60° 90° 180°
--------------	------------------------------	---	---	--	--	---

Değişik hidrolik basınçlar altında teorik bağlama gücünü gösteren şematik tablolar

Schematic view showing a theoretical clamping force under different hydraulic pressure:

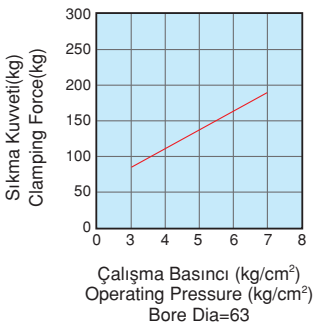
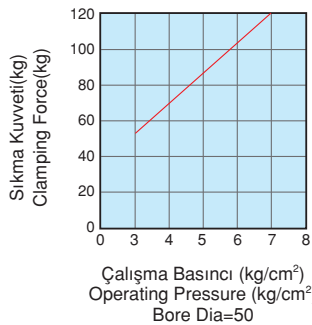
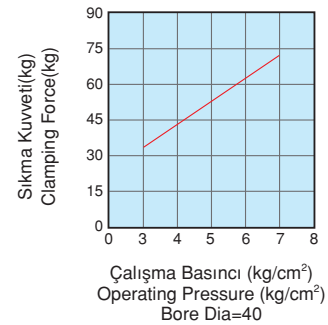
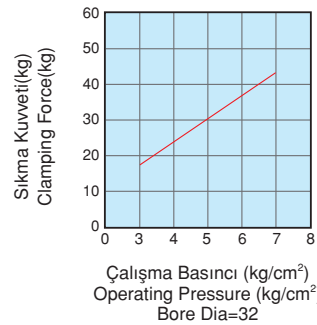
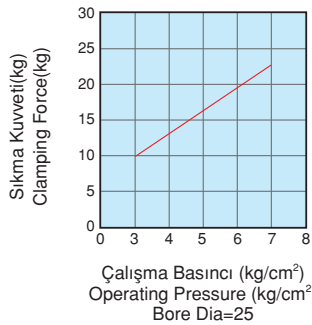

Referans Nr.	Bağlama Tipi Mounting Type	Bağlama Kolu Clamping Arm	Max. Basınç Max. Pressure	Normal Basınç Normal Pres.	Hareket Tipi Acting Type	Dönme Açısı Swivel Angle	Dönme Strok Swivel Stroke (mm)	Bağlama Strok Clamp. Str. (mm)	Delik Çapı / Bore Diameter Ø (mm)	Piston Çubuğu Piston Rod Ø	Bağl. Gücü/Clamp Force (5kg/cm ²)	A (mm) Sökme Unclamp	B (mm)	C (mm)	D (mm)	G (mm)	H (mm)	L1 Bağlama / Clamp L2 Sökme / Unclamp	I (mm)	P (mm)	Q (mm)	R (mm)	S (mm)	M (mm)	F (mm)	Ağırlık Weight (kg)
1058-NAS025	Flanş / Bottom Flange	Tel Kol / Single Arm	7 kg/cm ²	4-6 kg/cm ²	Çift Hareketli / Double Acting	90° (0° 45°, 60°, 180°) ± 2°	12	14	25	14	16	95.5	65.5	23	□ 16	30	8	M5	M6	30	40	Ø 4.5	Ø 35	18	12.5	0.40
1058-NAS032							12	14	32	16	30	102.5	71	23	□ 19	50	9	1/8 PF	M8	44	54	Ø 6.5	Ø 50	22	17	0.70
1058-NAS040							12	15	40	16	50	106	75	26	□ 19	50	9	1/8 PF	M8	48	58	Ø 6.5	Ø 55	26	19.5	0.85
1058-NAS050							14	15	50	20	85	113	80	26	□ 25.4	70	10	1/8 PF	M10	55	68	Ø 8.5	Ø 65	30	24	1.30
1058-NAS063							14	15	63	20	140	119	86	30	□ 25.4	70	10	1/8 PF	M10	64	80	Ø 8.5	Ø 70	40	20	1.80

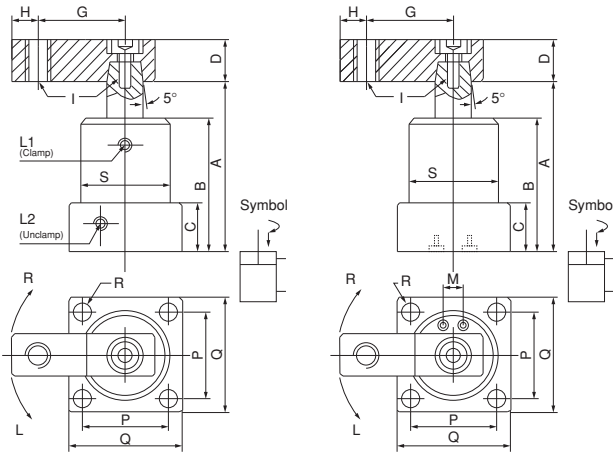

Ürün Nr. 1058 Pnömatik Dönmeli Bağlama
Product Nr. 1058 Pneumatic Swing Clamp

NAS – Flanşlı Uyarlama, Tek Kol Borulu veya Manifoldlu

NAS – Flange Version, Single Arm With Pipe or the Manifold

- Satın almadan önce hareket tipini ve dönme açısını bildiriniz.
- Before buying please, movement indicate the type and rotation angle.



Referans Nr.	Bağlama Tipi Mounting Type	Bağlama Kolu Clamping Arm	Max. Basınç Max. Pressure	Normal Basınç Normal Pres.	Hareket Tipi Acting Type	Dönme Açısı Swivel Angle	Dönme Strok Swivel Stroke (mm)	Bağlama Strok Clamp. Str. (mm)	Delik Çapı / Bore Diameter Ø (mm)	Piston Çubuğu Piston Rod Ø	Bağl. Gücü/Clamp Force (5kg/cm ²)	A (mm) Sökme Unclamp	B (mm)	C (mm)	D (mm)	G (mm)	H (mm)	L1 Bağlama / Clamp L2 Sökme / Unclamp	N (mm)	P (mm)	Q (mm)	R (mm)	S (mm)	M (mm)	F (mm)	Ağırlık Weight (kg)
1058-NASD032	Flanş / Bottom Flange	Çift Kol / Double Arm	7 kg/cm ²	4-6 kg/cm ²	Çift Hareketli / Double Acting	90° (0° 45°, 60°, 180°) ± 2°	12	14	32	16	30	102.5	71	23	□ 19	100	1/8 PF	Ø 8	44	54	Ø 6.5	Ø 50	22	17	0.80	
1058-NASD040							12	15	40	16	50	106	75	26	□ 19	100	1/8 PF	Ø 8	48	58	Ø 6.5	Ø 55	26	19.5	0.95	
1058-NASD050							14	15	50	20	85	113	80	26	□ 22	120	1/8 PF	Ø 8	55	68	Ø 8.5	Ø 65	30	24	1.40	
1058-NASD063							14	15	63	25	140	119	86	30	□ 22	120	1/8 PF	Ø 8	64	80	Ø 8.5	Ø 75	40	29	1.90	

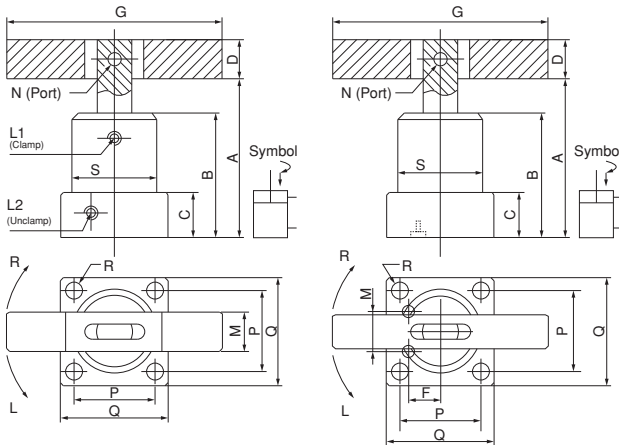

Ürün Nr. 1058 Pnömatik Dönmeli Bağlama
Product Nr. 1058 Pneumatic Swing Clamp

NASD – Flanşlı Uyarlama, Çift Kol Borulu veya Manifoldlu

NASD – Flange Version, Double Arms With Pipe or the Manifold

- Satın almadan önce hareket tipini ve dönme açısını bildiriniz.
- Before buying please, movement indicate the type and rotation angle.



Referans Nr.	Bağlama Tipi Mounting Type	Bağlama Kolu Clamping Arm	Max. Basınç Max. Pressure	Normal Basınç Normal Pres.	Hareket Tipi Acting Type	Dönme Açısı Swivel Angle	Dönme Strok Swivel Stroke (mm)	Bağlama Strok Clamp. Str. (mm)	Delik Çapı / Bore Diameter Ø (mm)	Piston Çubuğu Piston Rod Ø	Bağl. Gücü/Clamp Force (kg/cm ²)	A (mm) Sökme Unclamp	B (mm)	C (mm)	D (mm)	G (mm)	H (mm)	I (mm)	L1 Bağlama / Clamp L2 Sökme / Unclamp	N (mm)	S (mm)	T (mm) Kona Sim. 2 ad. T (mm) 2 pcs/set	Y (mm)	Ağırlık Weight (kg)
1058-NATS025	Dişli Gövde / Threaded Body	Tek Kol / Single Arm	7 kg/cm ²	4-6 kg/cm ²	Çift Hareketli / Double Acting	90° ± 2°	14	14	25	14	16	104	70	35	□ 16	50	6	10	M5	M6 x1	M40 x1.5	Ø 58	9	0.80
1058-NATS032							14	16	32	16	30	113	79	40	□ 19	60	9	13	1/8 PF	M8 x1.25	M50 x1.5	Ø 70	11	1.10
1058-NATS040							14	15	40	16	50	116	83	45	□ 19	70	9	13	1/8 PF	M8 x1.25	M55 x1.5	Ø 75	11	1.25
1058-NATS050							14	14	50	20	80	120	87	50	□ 25	80	10	13	1/8 PF	M12 x1.5	M65 x1.5	Ø 85	12	1.70
1058-NATS063							15	15	63	20	140	127	92	56	□ 25	90	10	13	1/8 PF	M12 x1.5	M80 x1.5	Ø 105	15	2.20

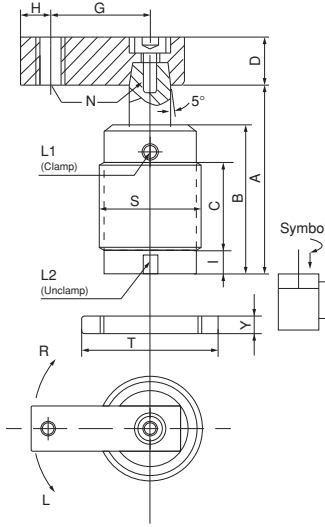

Ürün Nr. 1058 Pnömatik Dönmeli Bağlama Product Nr. 1058 Pneumatic Swing Clamp

NATS – Dişli Uyarlama, Tek Kol Borulu

NATS – Threaded Version, Single Arm With Pipe

- Satın almadan önce hareket tipini ve dönme açısını bildiriniz.
- Before buying please, movement indicate the type and rotation angle.



Pnömatik Dönmeli Bağlama

Pneumatic Swing Clamp

Referans Nr.	Bağlama Tipi Mounting Type	Bağlama Kolu Clamping Arm	Max. Basınç Max. Pressure	Normal Basınç Normal Pres.	Hareket Tipi Acting Type	Dönme Açısı Swivel Angle	Dönme Strok Swivel Stroke (mm)	Bağlama Strok Clamp. Str. (mm)	Delik Çapı / Bore Diameter Ø (mm)	Piston Çubuğu Piston Rod Ø	Bağl. Gücü/Clamp Force (kg/cm ²)	A (mm) Sökme Unclamp	B (mm)	C (mm)	D (mm)	G (mm)	I (mm)	L1 Bağlama / Clamp L2 Sökme / Unclamp	N (mm)	S (mm)	T (mm) Kona Sim. 2 ad. T (mm) 2 pcs/set	Y (mm)	Ağırlık Weight (kg)
1058-NATSD032	Dişli Gövde / Threaded Body	Çiftli Kol / Double Arm	7 kg/cm ²	4-6 kg/cm ²	Çift Hareketli / Double Acting	90° (0°-45°, 60°, 180°) ± 2°	14	16	32	16	30	113	79	40	□ 19	100	13	1/8 PT	Ø 8	M50 x1.5	Ø 70	11	1.10
1058-NATSD040							14	15	40	16	50	116	83	45	□ 19	100	13	1/8 PT	Ø 8	M55 x1.5	Ø 75	11	1.30
1058-NATSD050							14	14	50	20	85	120	77	50	□ 22	120	13	1/8 PT	Ø 8	M65 x1.5	Ø 85	12	1.80

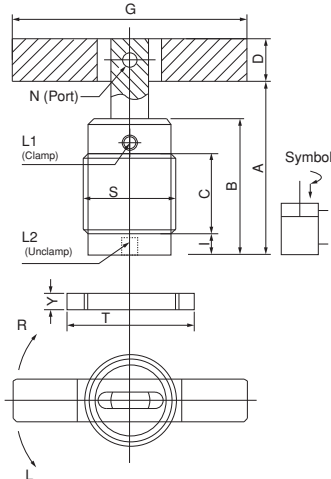

Ürün Nr. 1058 Pnömatik Dönmeli Bağlama Product Nr. 1058 Pneumatic Swing Clamp

NATSD – Dişli Uyarlama, Çift Kol Borulu

NATSD – Threaded Version, Double Arms With Pipe

- Satın almadan önce hareket tipini ve dönme açısını bildiriniz.
- Before buying please, movement indicate the type and rotation angle.



Referans Nr.	Çalışma Basıncı Operating Pressure	Çalışma Isısı Temperature Range	Bağlama Tipi Mounting Type	Strok Stroke (mm)	Delik Çapı/ Bore Diameter Ø (mm)	Piston Çubuğu Piston Rod Ø (mm)	A	B	C	D	E	F	G	H	I	J	K	L	M	O	N	P	Q	R	R1	S	L1 Bağlama / Clamp L2 Sokme / Uncilamp	Ağırlık Weight (kg)
1058-PLCU25	4-10 kgf/cm ²	-10° ~ +80°	Üst Flanş ve Dişli Gövde Upper Flange & Threaded Body	22	Ø 25	Ø 14	128.5	86.5	25	61.5	50	17	16	M40 x1.5	60	50	37	18	23	23	7	35	25	5.5	9	M6 x1	M5 x0.8	0.60
1058-PLCU32				28	Ø 32	Ø 16	149.5	97.5	25	72.5	57	20	18	M50 x1.5	70	60	45	22	30	23	8	40	30	6.5	11	M8 x1.25	G 1/8	1.00
1058-PLCU40				30	Ø 40	Ø 16	157.5	97.5	25	72.5	60	25	20	M55 x1.5	75	65	50	24	32	26	10	42.5	32.5	6.5	11	M8 x1.25	G 1/8	1.20
1058-PLCU50				30	Ø 50	Ø 20	174	104	25	79	65	30	22	M65 x1.5	88	75	58	27.5	36	32	14	50.5	37.5	8.5	14	M12 x1.75	G 1/8	2.00
1058-PLCU63				30	Ø 63	Ø 20	179	105	25	80	69	30	22	M80 x1.5	108	90	70	32	42	35	14	63	45	8.5	14	M12 x1.75	G 1/8	2.70

Ürün Nr. 1058 Pnömatik Üstten Bağlama

Product Nr. 1058 Pneumatic Above Clamp



Borulu / With Pipe

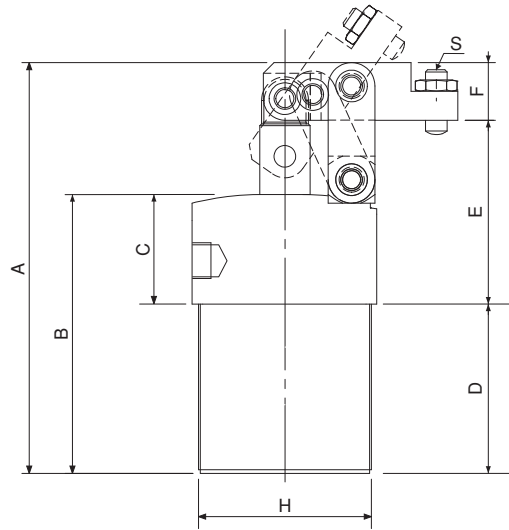
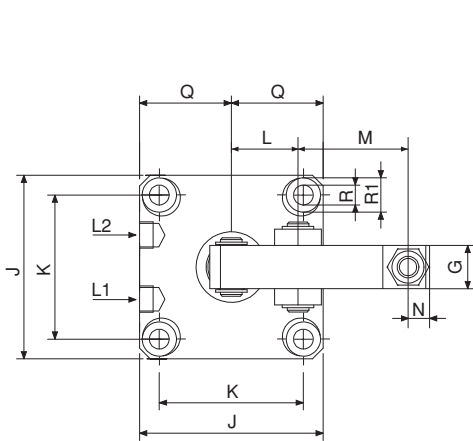

HİDROLİK FİKSTÜR UYGULAMALARI

HYDRAULIC FIXTURE APPLICATION

