

CNC YATAY İŞLEME KULELERİ

CNC HORIZONTAL CLAMPING CUBE

Nr.2670 Dikdörtgen kuleye
Nr.2310 çift açılır mengenerle
iş parçası bağlama şekli.

Nr.2670 clamping cube
with Nr.2310 vice applications

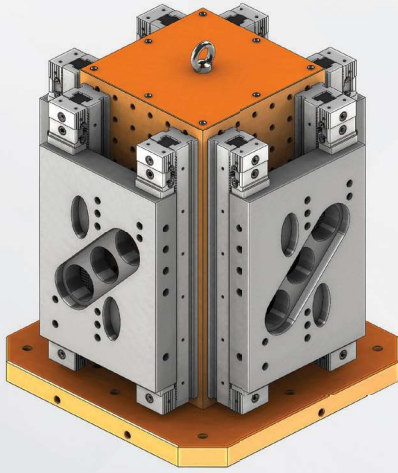
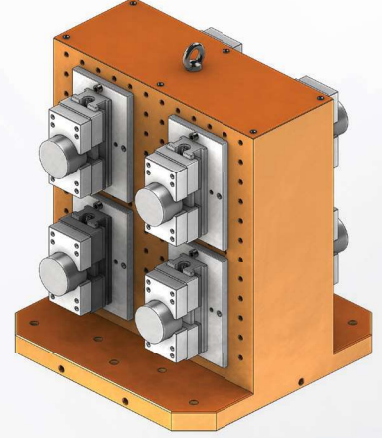

Nr.2650 kare kuleye
Nr.2430 mengenerle
iş parçası bağlama şekli

Nr.2650 clamping cube
with Nr.2430 vice applications

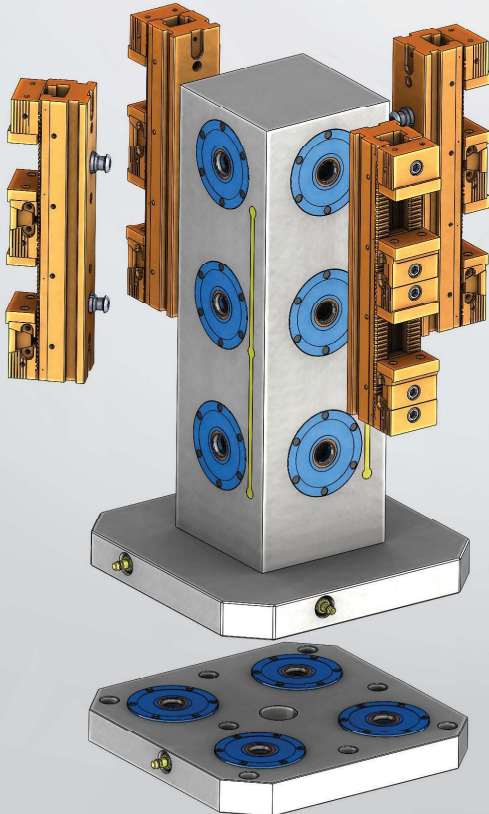

Nr.2650 kare kulenin
CNC yatay işleme tezgah
pleytine montaj şekli.

Nr.2650 clamping cube
CNC Horizontal machines
applications

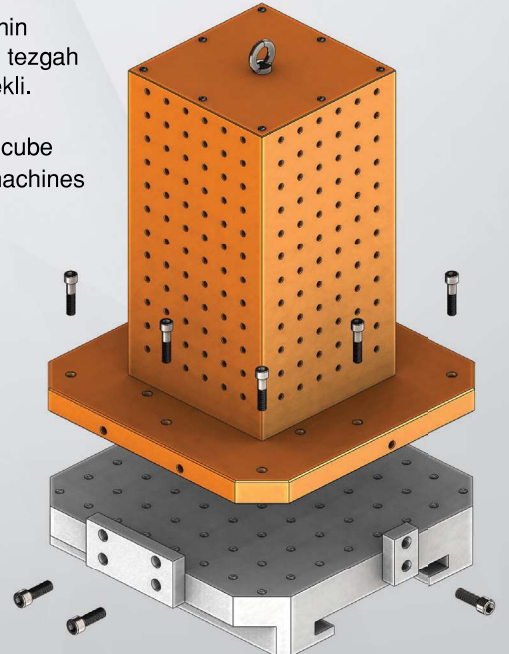

Referans Nr.	a	b	c	d	e	f	g	h	ØI	j	k	s	s1	(kg)
2570-30012	300	300	220	100	250	90	40	30	18	M12	75	25	170	50
2570-40012	400	400	280	160	320	90	40	30	18	M12	75	30	240	88
2570-50012	500	500	345	200	400	90	50	35	18	M12	75	35	300	175
2570-63012	630	630	435	250	500	100	50	40	18	M12	105	40	360	298
2570-30016	300	300	220	100	250	90	40	30	18	M16	75	25	170	45
2570-40016	400	400	280	160	320	90	40	30	18	M16	75	30	240	84
2570-50016	500	500	345	200	400	90	50	35	18	M16	75	35	300	170
2570-63016	630	630	435	250	500	100	50	40	18	M16	105	40	360	293

Referans Nr.	a	b	c	d	e	f	g	h	ØI		k	s	s1	(kg)
2575-30012	300	300	220	100	250	90	40	30	18	M12	75	25	170	50
2575-40012	400	400	280	160	320	90	40	30	18	M12	75	30	240	88
2575-50012	500	500	345	200	400	90	50	35	18	M12	75	35	300	175
2575-63012	630	630	435	250	500	100	50	40	18	M12	105	40	360	298
2575-30016	300	300	220	100	250	90	60	30	18	M16	75	25	170	60
2575-40016	400	400	280	160	320	90	60	30	18	M16	75	30	240	111
2575-50016	500	500	345	200	400	90	60	35	18	M16	75	35	300	176
2575-63016	630	630	435	250	500	100	65	40	18	M16	105	40	360	313

Ürün Nr. 2570 - 2575 L Gönye (Dişli)

- Malzeme : Döküm
- CNC yatay ve diik işleme tezgahlarında kullanılır.
- Standart bağlama ekipmanlarına uyumludur.
- Yüzeyinde M12 - M16 diş merkez aralığı 50 ± 0.02
- Nr. 2570 Gövdeye dişli
- Nr. 2575 Çelik burçlu

Product Nr. 2570 - 2575 L Setsquare (with Threaded)

- Material : Casting
- It is used in CNC Horizontal end Vertical processing benches.
- It is in compliance with Standard Coupling Equipment.
- M12 - M16 thread gap on it's surface is 50 ± 0.02 .
- Nr. 2570 Threaded body
- Nr. 2575 Steel bush

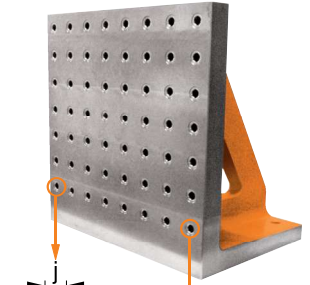
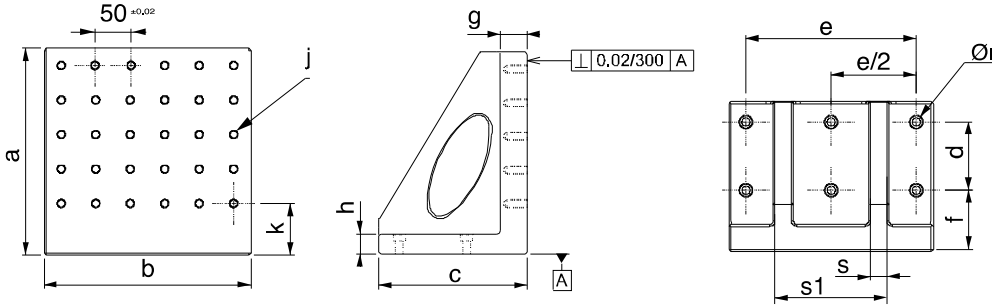

Gövdeye dişli
Referans Nr. 2570
Threaded body
Reference No. 2570

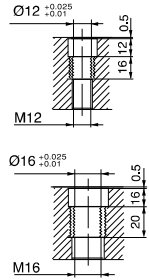

Çelik burçlu
Referans Nr. 2575
Steel bush
Reference No. 2575

Referans Nr.	a	b	c	d	e	f	g	h	ØI	j	k	L	s	s1	(kg)
2590-30014	300	300	220	100	250	90	60	30	18	14	100	50	25	170	50
2590-40014	400	400	300	160	320	90	60	30	18	14	100	50	30	240	100
2590-50014	500	500	350	200	400	90	60	35	18	14	100	50	35	300	185
2590-63014	630	630	450	250	500	100	65	40	18	14	125	65	40	360	315
2590-30018	300	300	220	100	250	90	60	30	18	18	100	50	25	170	50
2590-40018	400	400	300	160	320	90	60	30	18	18	100	50	30	240	98
2590-50018	500	500	350	200	400	90	60	35	18	18	100	50	35	300	174
2590-63018	630	630	450	250	500	100	65	40	18	18	125	65	40	360	286

Ürün Nr. 2590 L Gönye (T-Kanalı)

- Malzeme : Döküm
- CNC yatay ve diik işleme tezgahlarında kullanılır.
- Standart bağlama ekipmanlarına uyumludur.
- T-Kanal ölçüleri 14mm - 18mm DIN 650 standartındadır.

Product Nr. 2590 L Setsquare (with T-Slot)

- Material : Casting
- It is used in CNC Horizontal end Vertical processing benches.
- It is in compliance with Standard Coupling Equipment.
- T-Slot is in the standard of 14mm - 18mm DIN 650.

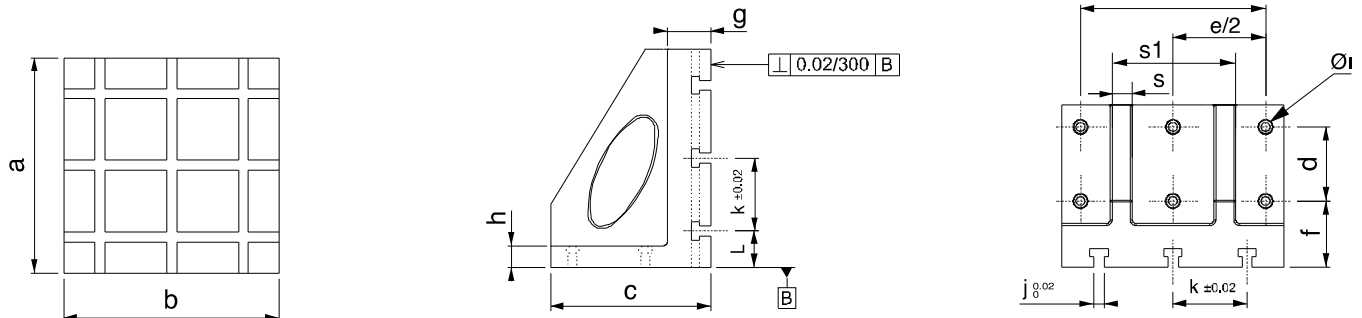

Referans Nr.	b	d	c	c1	A min.	A max.	Sıkma Kuvveti Clamping Force Kgf	Nm
2600-400400	400	160	320	-	-	-	5000	135
2600-500500	500	200	400	-	-	-	5000	135
2600-630630	630	250	500	-	-	-	5000	135

Ürün Nr. 2600 Çatal Kule

- Kullanım alanı: CNC yatay işleme, Borvekt tezgahlarında silindirik parçaların iki yüzeyinde işleme kolaylığı sağlar.
- Hareketli yüzeylerin tamamı hassas taşlanmış ve sertleştirilmiştir.

Product Nr. 2600 Fork Tower

- Application area: Provides better operation on both sides of cylindric workpieces on cnc horizontal machines and bohrwerks.
- Entire moving surface is sensitively grinded and hardened.

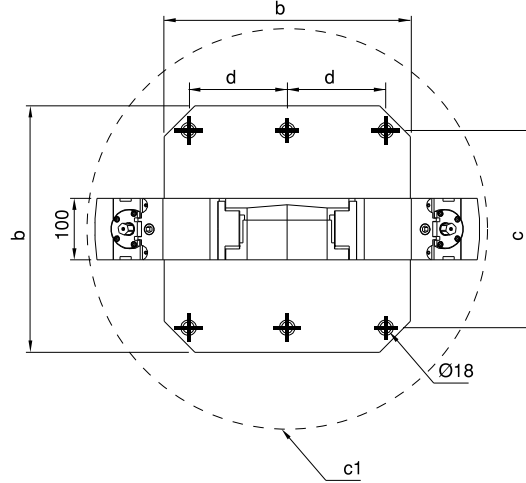
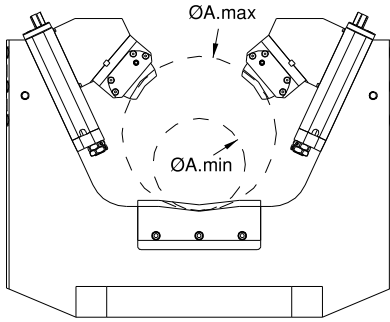

Oynar Başlı Çene
Head Moving Jaw

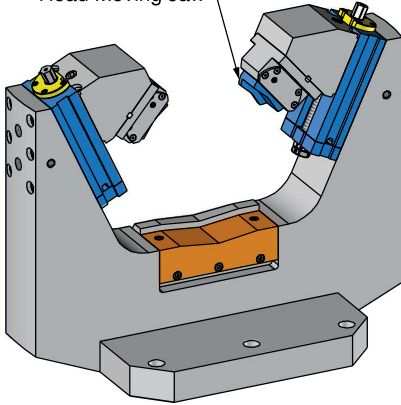

İş Parçası
Workpiece

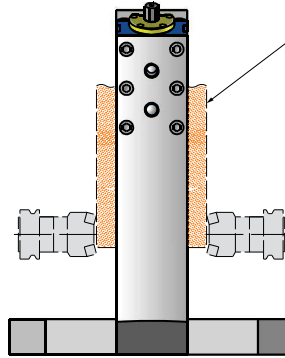

Referans Nr.	E	H	C min.	C max.	A min.	A max.	Sıkma Kuvveti Clamping Force kgf
2600-160350	250	275	0	130	160	350	2500

Ürün Nr. 2600 Ekstrüzyon Kalıbı Tesviye Mengenesi

• Özellikler: Ekstrüzyon kalıplarını tesviye ederken operatörün bedensel zorlanmasını önemli ölçüde azaltır. kalıbın kendi ekseninde 360° dönmesi diğer sabit mengenalere göre parçayı döndürme ve her yerine müdahale kolaylığı sağlar.

Product Nr. 2600 Extrusion Mold Leveling Vice

• Specifications: Significantly reduces operator strain when smoothing extrusion mould. The 360° rotation of the mold on its own axis makes it easy to rotate the part and intervene in all parts relative to other fixed vices.

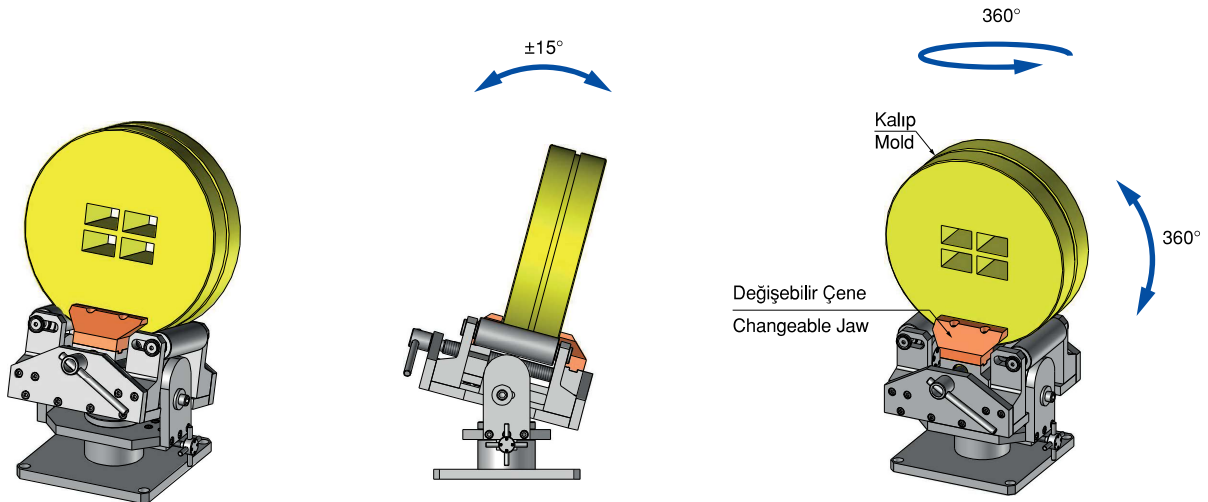
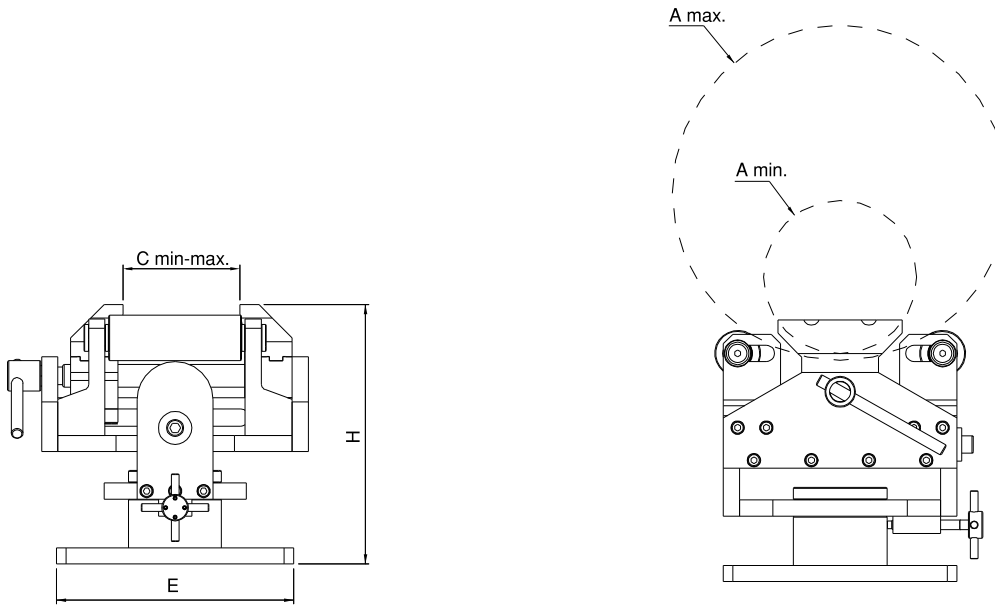

Referans Nr.	a	b	c	d	e	f	g	
2610-400250	500	400	250	320	200	55	50	180
2610-500300	600	500	300	400	250	75	50	240
2610-630350	700	630	350	500	315	100	50	390

Ürün Nr. 2610 Yatay İşleme Kulesi Kare

- İsteğe göre uygulama yapılabilmesi için yüzeyler deliksizdir.
- Malzeme : Döküm

Product Nr. 2610 Horizontal Processing Cube Square

- Application on the surface according to desired way.
- Material : Casting

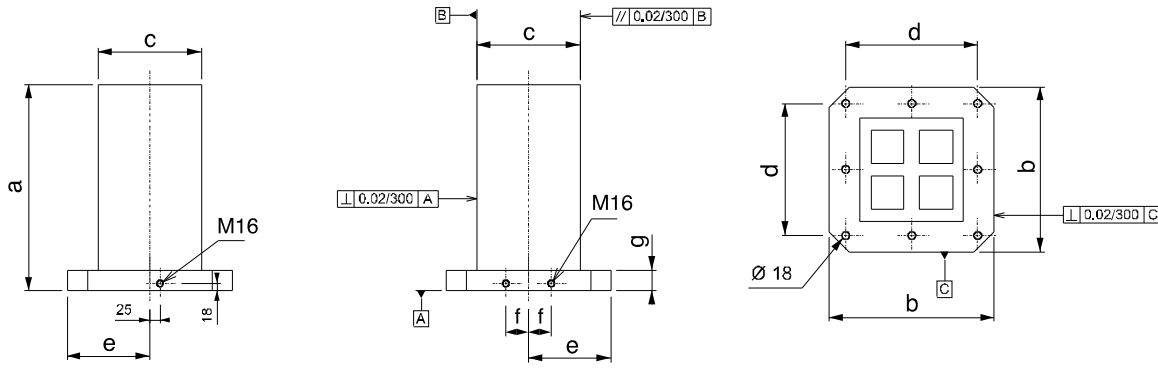

CNC Yatay İşleme Kulesi

CNC Horizontal Processing Cube

Referans Nr.	a	b	c	d	e	f	g	ı	k	J ($\frac{0,02}{}$)	
2630-40025014	500	400	250	320	200	55	50	150	100	14	165
2630-50030014	600	500	300	400	250	75	50	150	100	14	227
2630-63035014	700	630	350	500	315	100	50	150	125	14	375
2630-40025018	500	400	250	320	200	55	50	150	100	18	155
2630-50030018	600	500	300	400	250	75	50	150	100	18	223
2630-63035018	700	630	350	500	315	100	50	150	125	18	370

Ürün Nr. 2630 Yatay İşleme Kulesi Kare (T-Kanallı)

- Dört yüzeyine iş parçası bağlanabilir.
- Standart bağlama ekipmanlarına uyumludur.
- T-Kanal ölçüsü 14mm - 18mm DIN 650 standartındadır.
- Malzeme : Döküm

Product Nr. 2630 Horizontal Processing Cube Square (with T-Slot)

- Workpiece can be applied on four faces.
- It is in compliance with Standard Coupling Equipment.
- T-Slot is in the standard of 14mm - 18mm DIN 650.
- Material : Casting

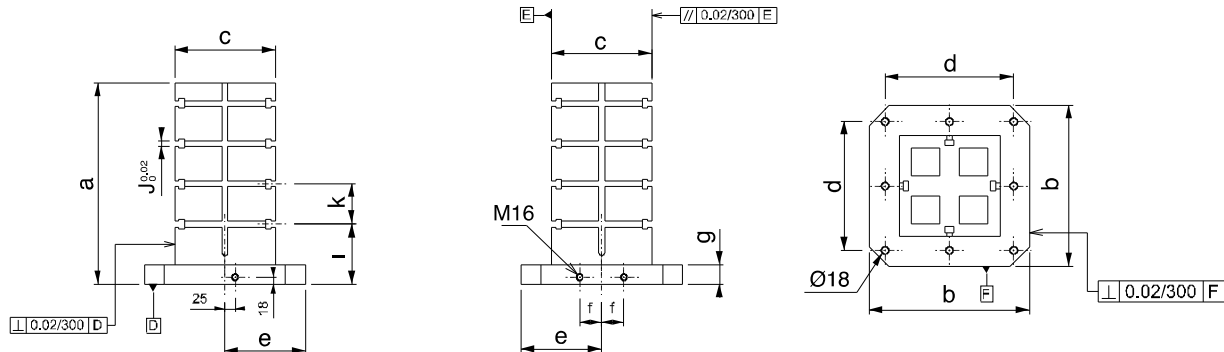

Referans Nr.	a	b	c	d	e	f	g		
2650-40025012	500	400	250	320	200	55	50	M12	170
2650-50030012	600	500	300	400	250	75	50	M12	230
2650-63035012	700	630	350	500	315	100	50	M12	380
2650-40025016	500	400	250	320	200	55	50	M16	168
2650-50030016	600	500	300	400	250	75	50	M16	228
2650-63035016	700	630	350	500	315	100	50	M16	376



Ürün Nr. 2650 Yatay İşleme Kulesi Kare (Dişli)

- Malzeme : Döküm
- Dört yüzeyine iş parçası bağlanabilir.
- Standart bağlama ekipmanlarına uyumludur.
- Her yüzeye M12 - M16 diş merkez aralığı 50mm \pm 0.02
- Gövdeye dişli

Product Nr. 2650 Horizontal Processing Cube Square (with Threaded)

- Material : Casting
- Workpiece can be applied on four faces.
- It is in compliance with Standard Coupling Equipment.
- M12 - M16 thread gap on it's surface is 50 ± 0.02 .
- Threaded body

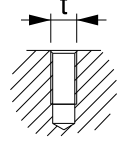
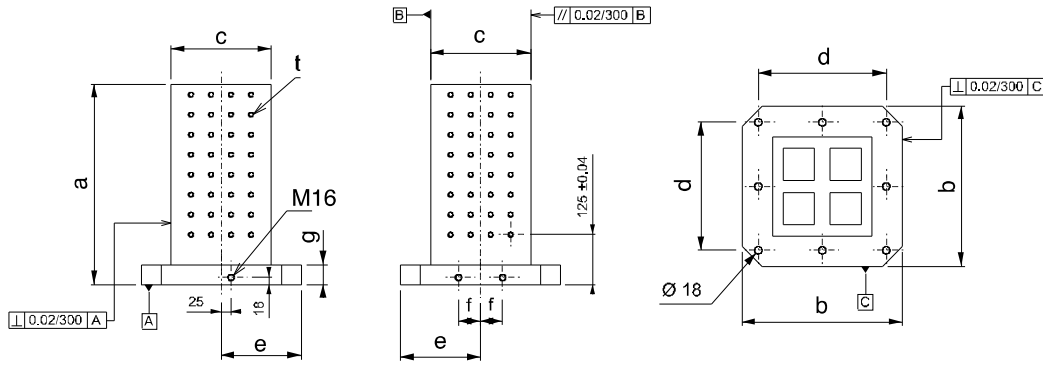

Gövdeye dişli
Threaded body

CNC Yatay İşleme Kulesi

CNC Horizontal Processing Cube

Referans Nr.	a	b	c	d	e	f	g		
2660-40025012	500	400	250	320	200	55	50	M12	170
2660-50030012	600	500	300	400	250	75	50	M12	230
2660-63035012	700	630	350	500	315	100	50	M12	380
2660-40025016	500	400	250	320	200	55	50	M16	168
2660-50030016	600	500	300	400	250	75	50	M16	228
2660-63035016	700	630	350	500	315	100	50	M16	376

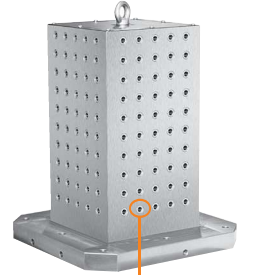

Ürün Nr. 2660 Yatay İşleme Kulesi Kare (Çelik Burçlu)

- Malzeme : Döküm
- Dört yüzeyine iş parçası bağlanabilir.
- Standart bağlama ekipmanlarına uyumludur.
- Her yüzeye M12 - M16 diş merkez aralığı 50mm \pm 0.02
- Çelik burçlu

Product Nr. 2660 Horizontal Processing Cube Square (with Steel Bush)

- Material : Casting
- Workpiece can be applied on four faces.
- It is in compliance with Standard Coupling Equipment.
- M12 - M16 thread gap on it's surface is 50 ± 0.02 .
- Steel bush

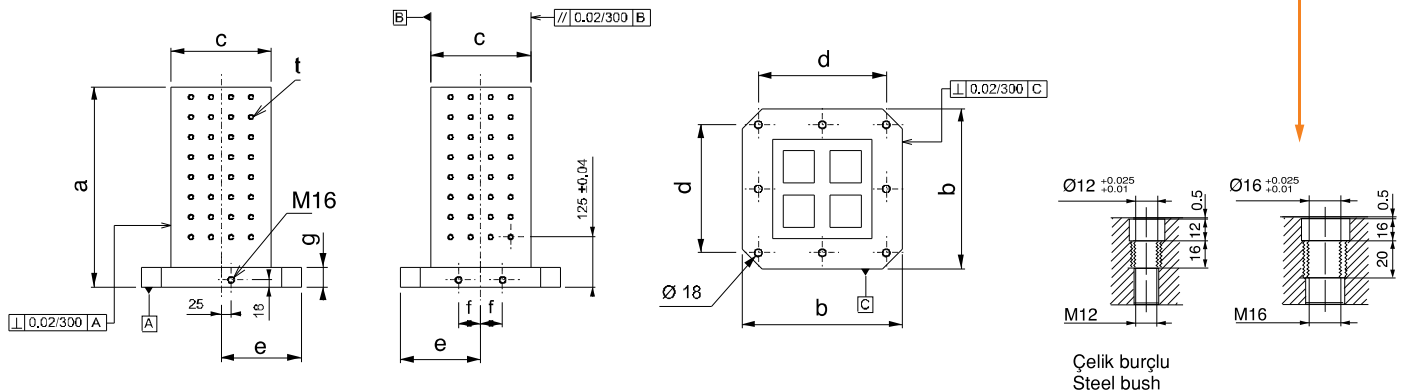

Çelik burçlu
Steel bush

Referans Nr.	a	b	c	d	e	f	g	(kg)
2670-400150	500	400	150	320	200	55	50	175
2670-500200	600	500	200	400	250	75	50	265
2670-630250	700	630	250	500	315	100	50	484

Ürün Nr. 2670 Yatay İşleme Kulesi Dikdörtgen

- İsteğe göre uygulama yapılabilmesi için yüzeyler deliksizdir.
- Malzeme : Döküm

Product Nr. 2670 Horizontal Processing Cube Rectangular

- Application on the surface according to desired way.
- Material : Casting

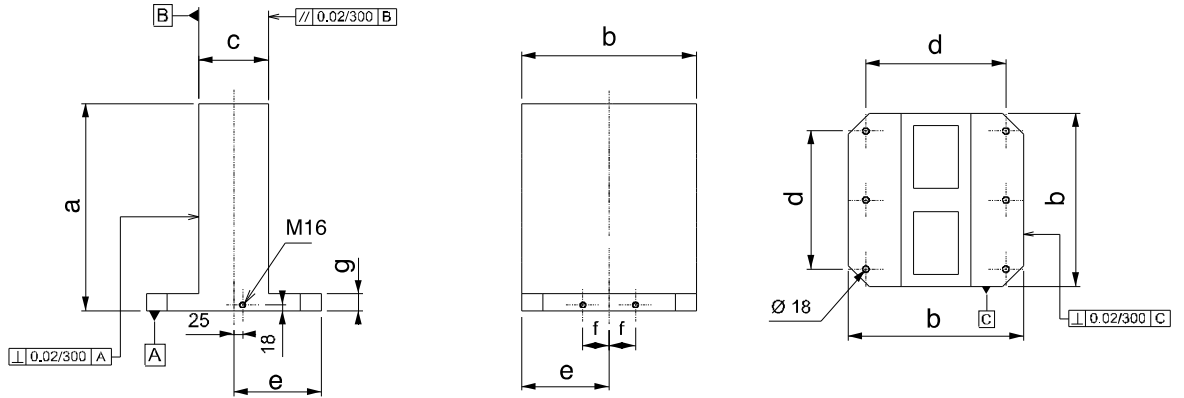

Referans Nr.	a	b	c	d	e	f	g	i	k (±0.02)	J ($\frac{0.02}{6}$)	(kg)
2690-40015014	500	400	150	320	200	55	50	150	100	14	165
2690-50020014	600	500	200	400	250	75	50	150	100	14	240
2690-63025014	700	630	250	500	315	100	50	150	125	14	455
2690-40015018	500	400	150	320	200	55	50	150	100	18	152
2690-50020018	600	500	200	400	250	75	50	150	100	18	238
2690-63025018	700	630	250	500	315	100	50	150	125	18	450

Ürün Nr. 2690 Yatay İşleme Kulesi Dikdörtgen (T-Kanallı)

- İki yüzeyine iş parçası bağlanabilir.
- Standart bağlama ekipmanlarına uyumludur.
- T-Kanal ölçüsü 14mm - 18mm DIN 650 standartındadır.
- Malzeme : Döküm

Product Nr. 2690 Horizontal Processing Cube Rectangular (with T-Slot)

- Workpiece can be applied on four faces.
- It is in compliance with Standard Coupling Equipment.
- T-Slot is in the standard of 14mm - 18mm DIN 650.
- Material : Casting

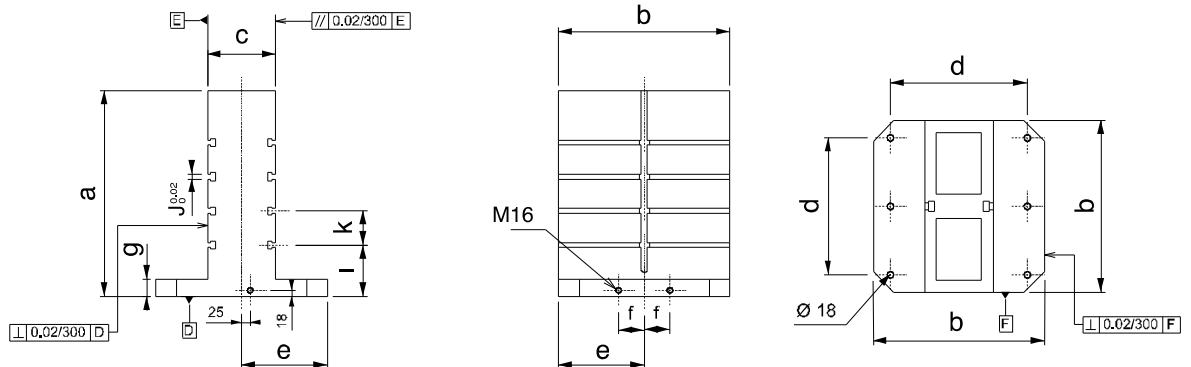

Referans Nr.	a	b	c	d	e	f	g		
2710-40015012	500	400	150	320	200	55	50	M12	170
2710-50020012	600	500	200	400	250	75	50	M12	250
2710-63025012	700	630	250	500	315	100	50	M12	475
2710-40015016	500	400	150	320	200	55	50	M16	164
2710-50020016	600	500	200	400	250	75	50	M16	248
2710-63025016	700	630	250	500	315	100	50	M16	470

Ürün Nr. 2710 Yatay İşleme Kulesi Dikdörtgen (Dişli)

- Malzeme : Döküm
- İki yüzeyine iş parçası bağlanabilir.
- Standart bağlama ekipmanlarına uyumludur.
- İki yüzeye M12 - M16 diş merkez aralığı 50mm ±0.02
- Gövdeye dişli

Product Nr. 2710 Horizontal Processing Cube Rectangular (with Threaded)

- Material : Casting
- Workpiece can be applied on two faces.
- It is in compliance with Standard Coupling Equipment.
- M12 - M16 thread gap on it's surface is 50 ± 0.02.
- Threaded body

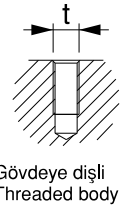
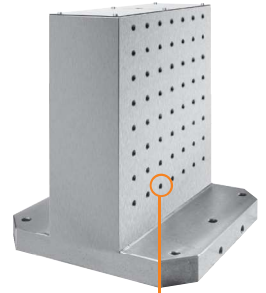

Gövdeye dişli
Threaded body

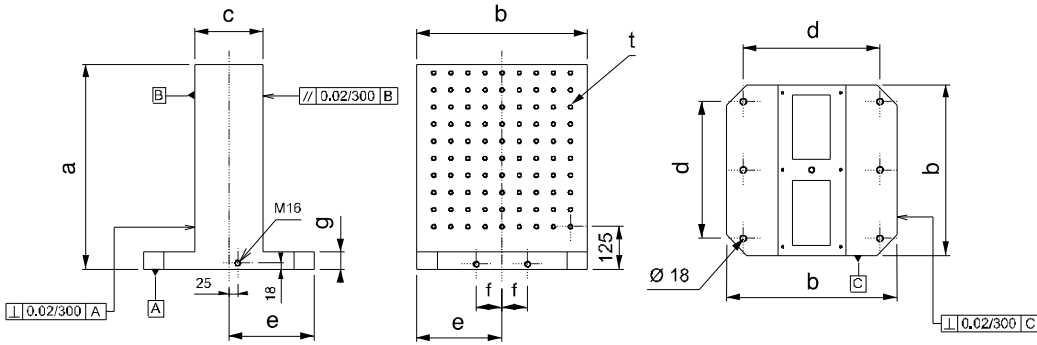

CNC Yatay İşleme Kulesi

CNC Horizontal Processing Cube

Referans Nr.	a	b	c	d	e	f	g		
2720-40015012	500	400	150	320	200	55	50	M12	170
2720-50020012	600	500	200	400	250	75	50	M12	250
2720-63025012	700	630	250	500	315	100	50	M12	475
2720-40015016	500	400	150	320	200	55	50	M16	164
2720-50020016	600	500	200	400	250	75	50	M16	248
2720-63025016	700	630	250	500	315	100	50	M16	470

Ürün Nr. 2720 Yatay İşleme Kulesi Dikdörtgen (Çelik Burçlu)

- Malzeme : Döküm
- İki yüzeyine iş parçası bağlanabilir.
- Standart bağlama ekipmanlarına uyumludur.
- İki yüzeye M12 - M16 diş merkez aralığı 50mm ±0.02
- Çelik burçlu

Product Nr. 2720 Horizontal Processing Cube Rectangular (with Steel Bush)

- Material : Casting
- Workpiece can be applied on two faces.
- It is in compliance with Standard Coupling Equipment.
- M12 - M16 thread gap on it's surface is 50 ± 0.02.
- Steel bush

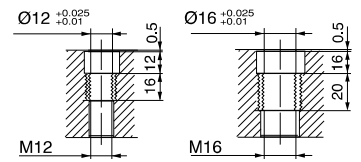
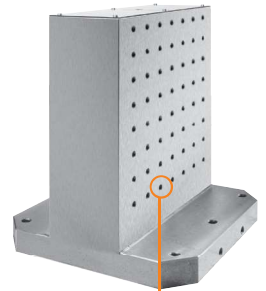

Çelik burçlu
Steel bush

