

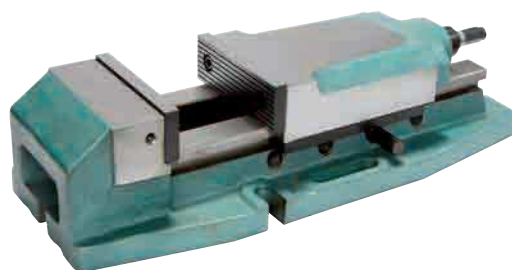

# Schraubstöcke

*Vices*



Referenz-Nr. Order No.	a	a1	b	c	e	f	h	L	i	s	n	Spannkraft clamping force kgf	 (kg)
2300-127130	170	127	0-130	63	112	209	112	374	115	100	49	2750	31

**2300**

- Wichtigste Eigenschaft: Der Grip-Schraubstock passt sich dem Werkstück an.  
Bei Bedarf wird die Form festgesetzt ( siehe bilder untetn 1-2-3-4)
- Backe: Gehärtet



**2300**

- Clamping jaws need to be connected to this form and take the form according to the workpiece to be set permanently, the most important feature of the vice grip. (1-2-3-4 shape as shown in)
- Jaw : Hardened

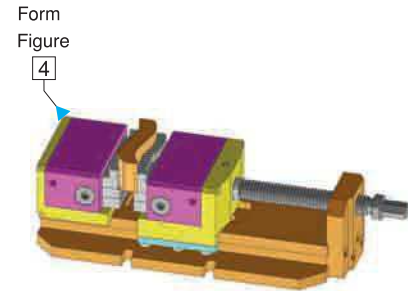
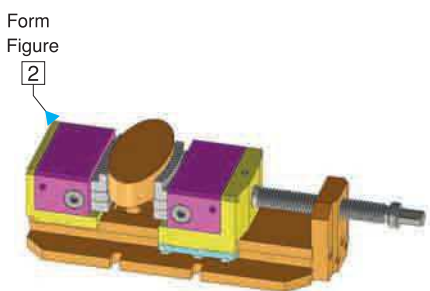
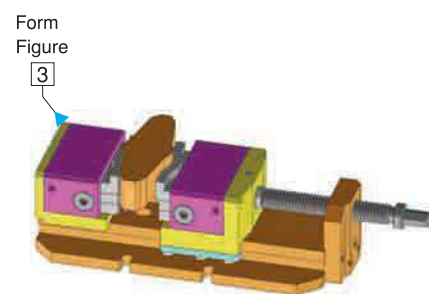
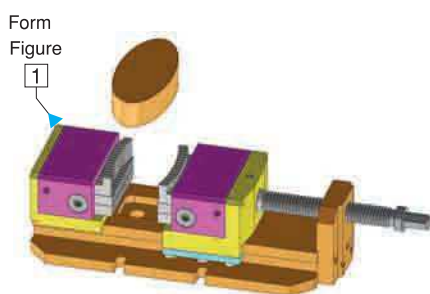
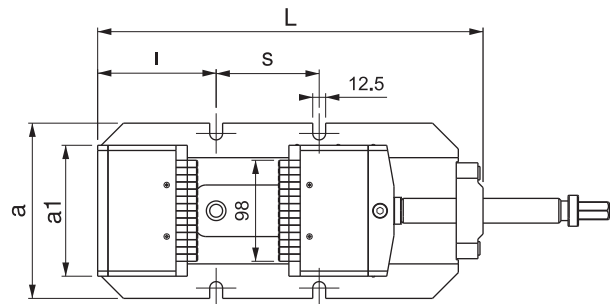
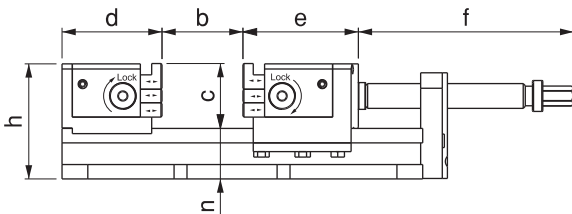

Referenz-Nr. Order No.	A min-max	Strok	hydraulisch hydraulic Bar	Spannkraft Clamping Force kgf	(kg)
2305-0251	0 - 251	13 x 2	30	750	15.2
			40	1000	
			50	1250	
			60	1500	



### 2305

- Beim Werkstückspannen wird gleichzeitig zentriert.
- Der Vorteil dieses Systems ist, dass besonders bei unterschiedlichen Außendurchmessern ohne zusätzliches Zentrieren bearbeitet werden kann.
- Weiterer Vorteil: Weichbacken können dem Werkstück angepasst werden (siehe Bild 1-2-3-4)
- Sämtliche bewegliche Flächen sind feingeschliffen.
- System hydraulisch betrieben
- Ölzufluss - Ölausfluss
- Schwarz beschichtet

### 2305

- This product fixes the material to be processes and at the same time it makes centering. The advantage of this system specially shows itself when making machinings of the materials having different outer diameter measurements as it implements this process without changing the center. It's other characteristic is to apply the form of the piece to be machined with soft jaws (as seen in Figures: 1-2-3-4-5 and 6).
- Entire moving surface is sensitively grinded and hardened.
- Hydraulic system works
- Oil inlet - Oil outlet
- Black coating

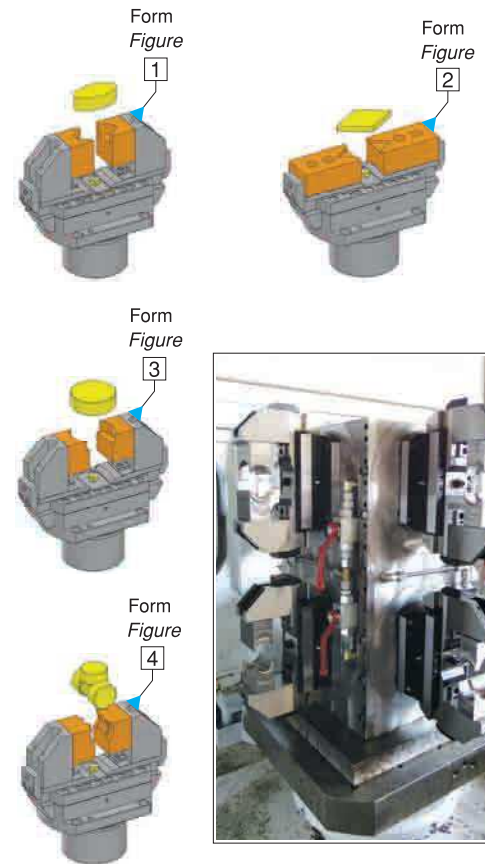
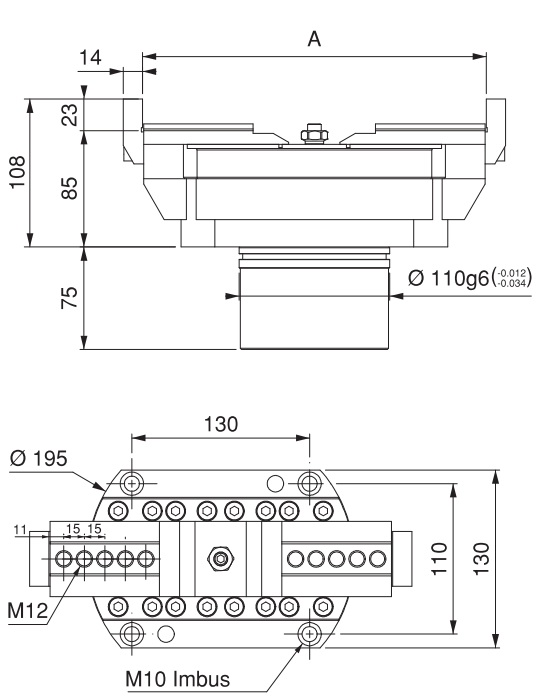

# Pneumatischer Zentrierschraubstock

## Pneumatic Centering Vice

Referenz-Nr. Order No.	A min-max	Strok	pneumatisch pneumatic Bar	Spannkraft Clamping Force kgf	(kg)
2307-0188	0-188	8.5x2	6	750	18.5

### 2307

- Pneumatikbetrieb

### 2307

- Pneumatic system works

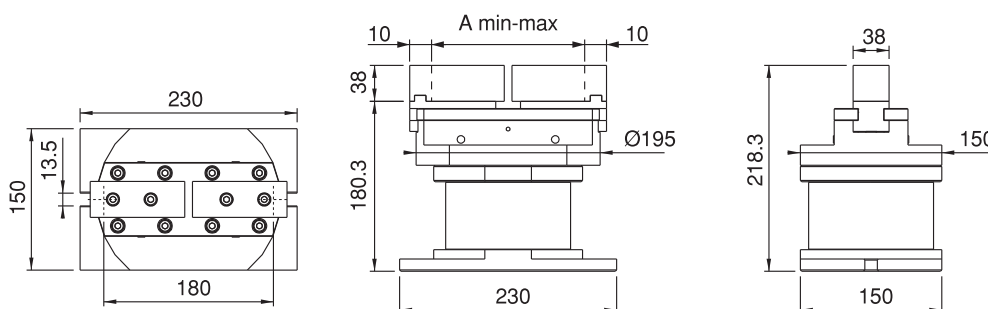

## Mechanischer Schraubstock Anwendungsbeispiel

*Mechanical Steel Vice Application*





Ref.-Nr. Order No.	a	L	c/2	öffnen opens 2 x mm	Werkstückspannkapazität work piece coupling capacity (mm)	b	b1	b2 ±0,02	b3	p1	p2	s1	s2	Spannkraft Clamping Force kgf	Drehmoment Allowable Screw Torque (N·m)	sw	
2310-060	60	120	90	20	120	23.5	70.5	67.5	91	174	124	150	100	800	45	9	7
2310-078	78	180	130	30	180	33	97	93	126	224	124	200	100	1500	110	12	14
2310-100	100	220	154	38	220	35	99	95	130	274	174	250	150	1500	110	12	22
2310-125	125	260	174	47	260	38	108	103	141	324	174	300	150	2000	190	14	35
2310-157	157	350	208	75	350	46	123	118	164	424	224	400	200	2200	210	17	65



**2310**

- Zentrieren automatisch beim Spannen
- Vorteil: verwendbar auch bei unterschiedlichen Abmessungen (siehe Abb. 1-2-3-4-5-6)
- Verwendung: Fräsen CNC und mechanisch, Schleifen und sonstige Industriemaschinen
- Backen müssen separat bestellt werden.
- Schwarz beschichtet

**2310**

- This product fixes the material to be processes and at the same time it makes centering. The advantage of this system specially shows itself when making machinings of the materials having different outer diameter measurements as it implements this process without changing the center. It's other characteristic is to apply the form of the piece to be machined with soft claws (as seen in Figures: 1-2-3-4-5 and 6).
- Area of Using: This product is used in various industry machines such as CNC and mechanical milling machines, grinding and auger.
- Entire moving surface is sensitively grinded and hardened.
- You need to purchase jaws separate.
- Black coating

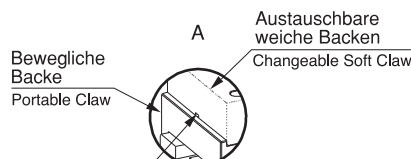
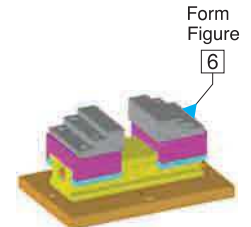
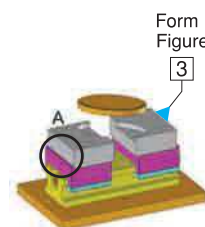
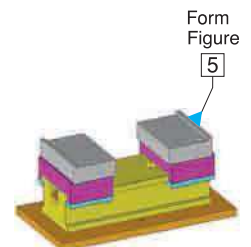
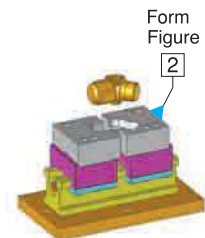
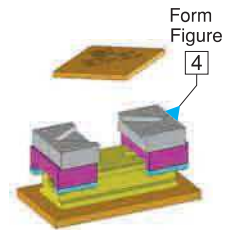
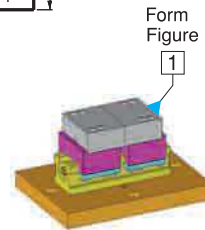
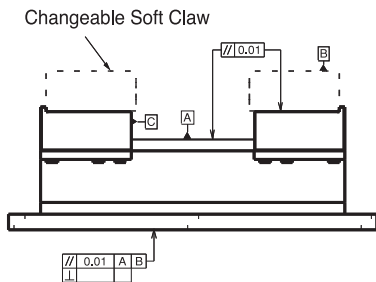
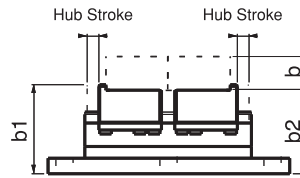
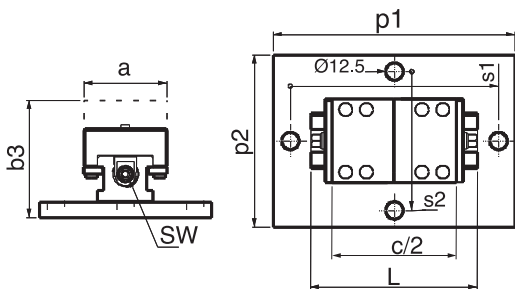

Wiederholgenauigkeit Demontage und Montage von weichen Backen ist ±0.02.  
Demounting and mounting of portable jaw wedge soft claws is ±0.02.

Ref.-Nr. Order No.	a	L	c/2	öffnen opens 2 x mm	b1	b2 ±0,02	p1	p2	s1	Spannkraft Clamping Force kgf	Drehmoment Allowable Screw Torque (N-m)	sw	 (kg)
2315-060	60	120	90	20	117.5	114.5	174	56	150	800	45	9	4.1
2315-078	78	180	130	30	159	155	224	73.5	200	1500	110	12	10
2315-100	100	220	154	38	159	155	274	95	250	1500	110	12	17.2

### 2315

- Dieses Produkt fixiert das zu bearbeitende Werkstück und führt gleichzeitig eine Zentrierung durch. Der Vorteil dieses Systems zeigt sich besonders bei der Bearbeitung von Materialien mit unterschiedlichen Außendurchmessern, da es diesen Prozess ohne Wechsel des Zentrums durchführt.
- Anwendungsbereiche: CNC Maschinen und 5-Achs Bearbeitungszentren
- Die gesamte Lauffläche ist fein geschliffen und gehärtet.
- Backen müssen separat bestellt werden.
- Schwarz beschichtet

### 2315

- This product fixes the material to be processes and at the same time it makes centering. The advantage of this system specially shows itself when making machinings of the materials having different outer diameter measurements as it implements this process without changing the center.
- Area of Using: This product is used in various industry machines such as CNC and CNC 5-Axis mechanical milling machines,
- Entire moving surface is sensitively grinded and hardened.
- You need to purchase jaws separate.
- Black coating

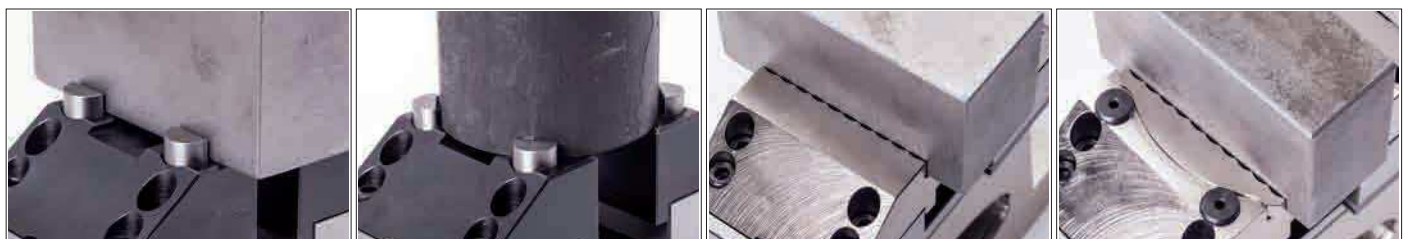
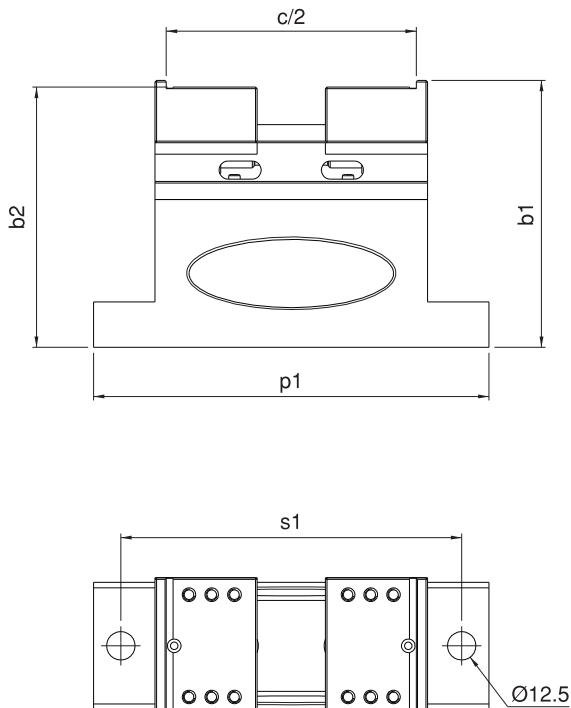

Referenz-Nr. Order No.	f min-max	h	h1	L1	a
2310-23150601	10-50	16.5	23.5	45	60
2310-23150781	10-70	26	33	65	78
2310-23151001	10-86	28	35	77	100
2310-23151251	10-104	31	38	87	125
2310-23151571	10-160	39	46	104	157

- Gehärtet • Hardened
- Nickelbeschichtung • Nickel Coating

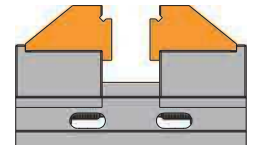
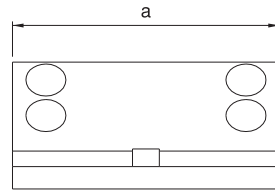
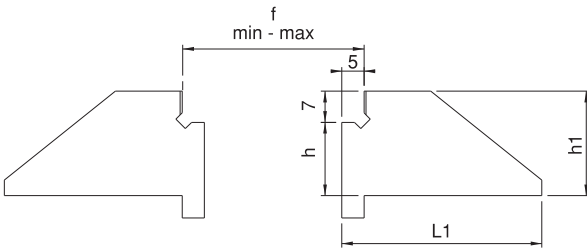

Passend für Produktnr.  
2310 und 2315

Referenz-Nr. Order No.	f min-max	h	h1	L1	a
2310-23150602	8-48	20.5	23.5	45	60
2310-23150782	8-68	29	33	65	78
2310-23151002	8-84	31	35	77	100
2310-23151252	8-102	34	38	87	125
2310-23151572	8-158	46	46	104	157

- Gehärtet • Hardened
- Nickelbeschichtung • Nickel Coating

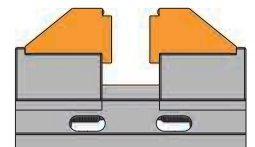
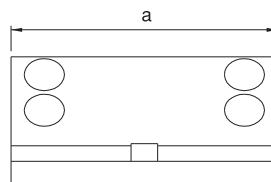
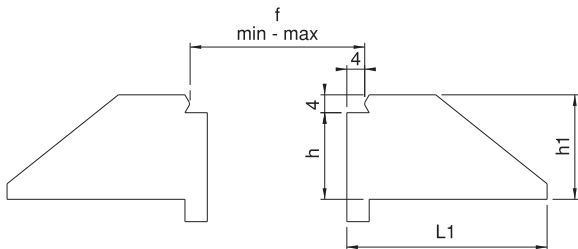

Passend für Produktnr.  
2310 und 2315

Referenz-Nr. Order No.	f min-max	h	h1	L1	a
2310-23150603	10-50	16.5	23.5	47	60
2310-23150783	10-70	26	33	67	78
2310-23151003	10-86	28	35	79	100

- Gehärtet • Hardened
- Nickelbeschichtung • Nickel Coating

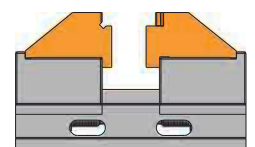
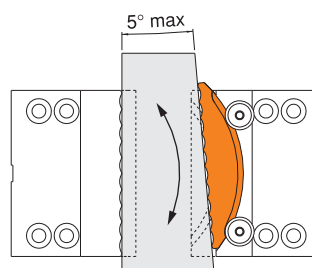
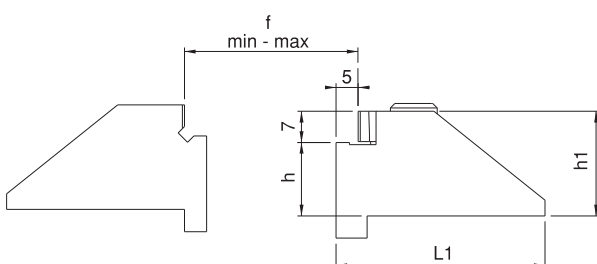

Passend für Produktnr.  
2310 und 2315

Referenz-Nr. Order No.	f		h	h1	L1	a
	min	max				
2310-23150604	46-72	23-63	23.5	27.5	45	60
2310-23150784	59-95	23-83	33	37	65	78
2310-23151004	77-124	23-99	35	39	77	100

- Vor dem Kauf bitte die Backeneigenschaft angeben. (Verzahnt oder Glatt)
- Gehärtet
- Schwarz beschichtet

- You should specify the jaw feature before make purchase.(Serrated or Straight)
- Hardened
- Black Coating

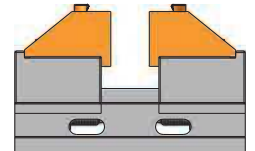
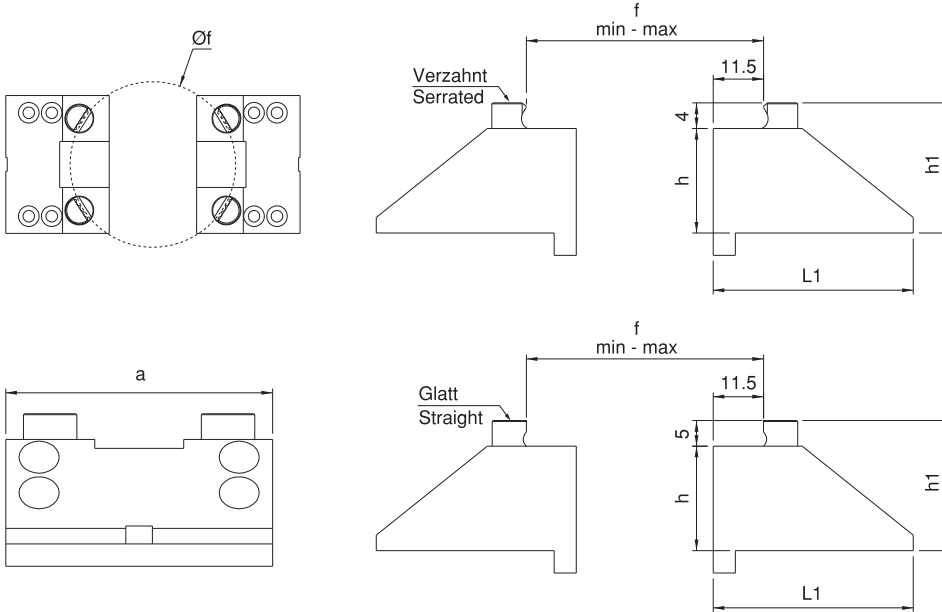

Passend für Produktnr. 2310 und 2315

Referenz-Nr. Order No.	f		h	h1	g	L1	a
	min	max					
2310-23150605	10-50	20-60	7	23.5	9.5	45	60
2310-23150785	10-70	20-80	10	33	16	65	78
2310-23151005	10-86	20-96	10	35	18	77	100
2310-23151255	10-104	20-114	10	38	21	87	125
2310-23151575	10-160	20-170	10	46	29	104	157

- Gehärtet
- Schwarz beschichtet

- Hardened
- Nickel Coating

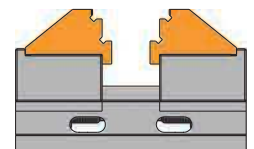
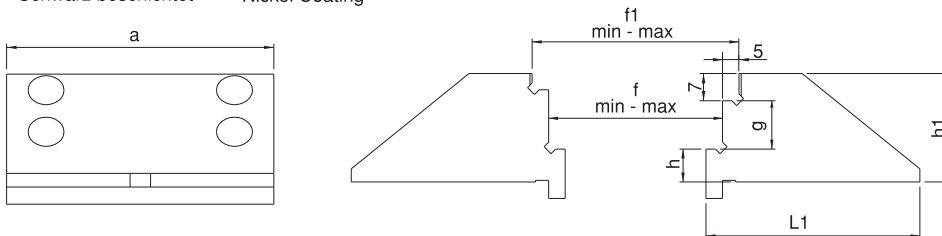

Passend für Produktnr. 2310 und 2315

Referenz-Nr. Order No.	a	b	c
2310-23150606	60	23.5	45
2310-23150786	78	33	65
2310-23151006	100	35	77
2310-23151256	125	38	87
2310-23151576	157	46	104

### Weiche Backe Soft Jaw

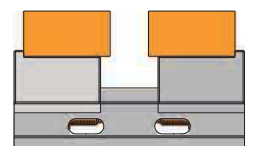
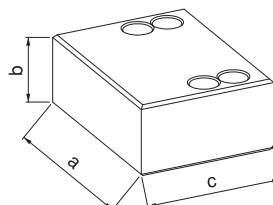

Passend für Produktnr. 2310 und 2315

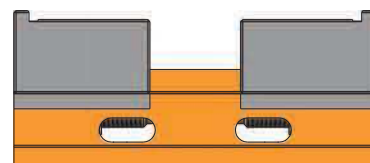

Referenz-Nr. Order No.
2310-2315-060AG
2310-2315078AG
2310-2315100AG
2310-2315125AG
2310-2315157AG

**Grundkörper  
Sub-body**

Referenz-Nr. Order No.
2310-2315060GÇ
2310-2315078GÇ
2310-2315100GÇ
2310-2315125GÇ
2310-2315157GÇ

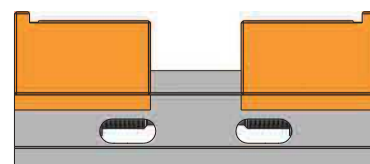
**Bewegliche Backe  
Portable Jaw**

Referenz-Nr. Order No.
2310-2315060M
2310-2315078M
2310-2315100M
2310-2315125M
2310-2315157M

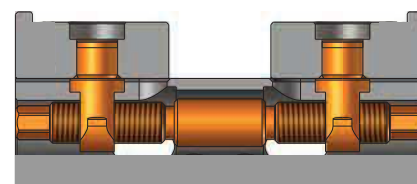
**Spindel  
Pin**

Referenz-Nr. Order No.	b	Spannkraft Clamping Force kgf	 (kg)
2320-160200	0-200	4500	60

**2320**

- Verwendung: Fräsen CNC und mechanisch, Schleifen und sonstige Industriemaschinen
- Aktivflächen komplett feingeschliffe und feingehärtet

**2320**

- Area of Using: CNC and mechanical milling machines, drilling machines, various industrial machines
- Entire moving surface is sensitively grinded and hardened.

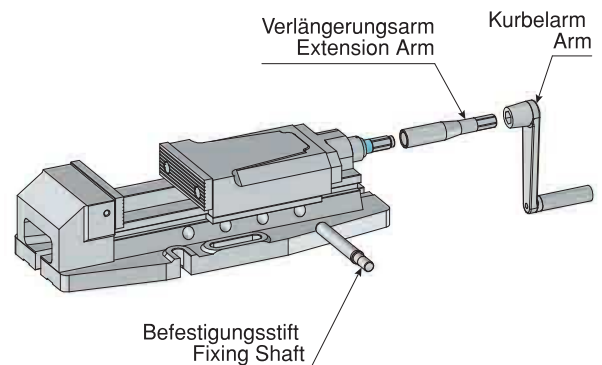
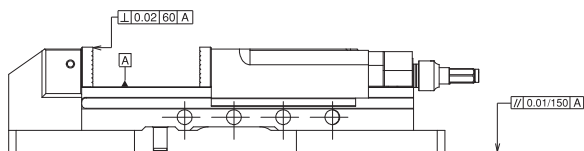
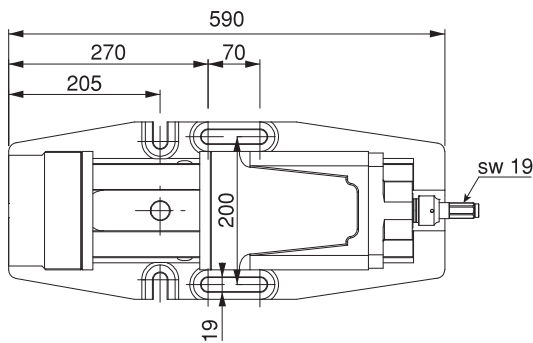
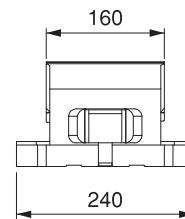
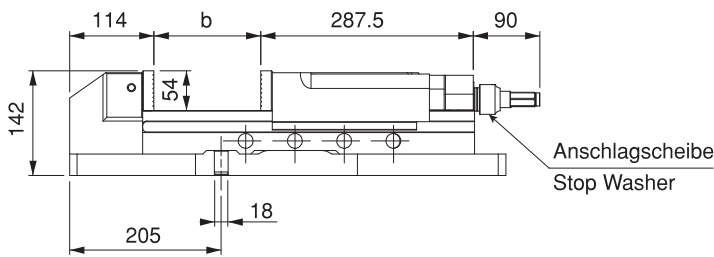
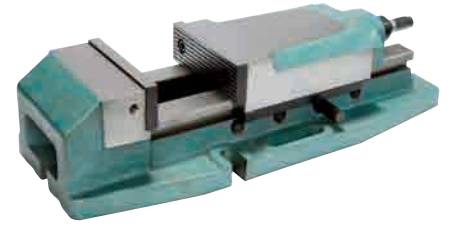

Referenz-Nr. Order No.	a	b	c	L	d	e	f	h	i	n	s	Spannkraft clamping force kgf	Drehmoment Allowable Screw Torque (N-m)	 (kg)
2330-127160	127	0-160	60	422	99	78	160	115	125	55	200	4500	170	28
2330-157200	157	0-200	60	462	99	78	160	115	150	55	200	4500	170	46
2330-157300	157	0-300	60	562	99	78	160	115	150	55	250	4500	170	51
2330-197300	197	0-300	60	562	99	78	160	115	150	55	250	4500	170	66
2330-197400	197	0-400	60	662	99	78	160	115	150	55	350	4500	170	73
2330-197500	197	0-500	60	762	99	78	160	115	150	55	250/250	4500	170	80



### 2330

- gehärtet und feingeschliffen Aufgrund Federsystem wird das Werkstück nach unten gespannt  
Aktivflächen komplett fein geschliffen
- Verwendung: Fräsen CNC und mechanisch, Schleifen und sonstige Industriemaschinen
- Aktivflächen komplett feingeschliffen und feingehärtet

### 2330

- Mechanical Steel Vice is hardened and it has excellent way of using because of being sensitively grinded.  
It's usage characteristic fixes the material to be machined and at the same time it pulls the material to the base of the vice because of having springed system of modular jaws taking place in the moving jaws. Entire moving surface is sensitively grinded. With it's wedged fixing characteristic, moving jaw distance can be adjusted rapidly and can be used with convenience.
- Area of Using: CNC and mechanical milling machines, grinding and drilling machines, various industrial machines
- Entire moving surface is sensitively grinded and hardened.

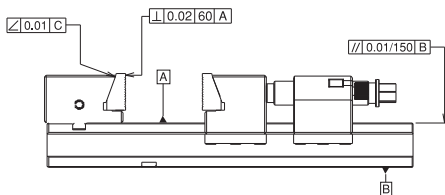
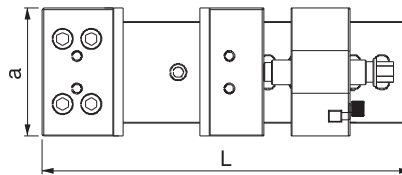
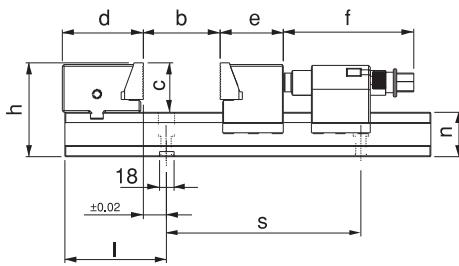



## Mittlerer Teil zum Spannen von zwei Werkstücken

Medium Part to Connect Two Work Piece

Referenz-Nr. Order No.	b1	 (kg)
2330-127	50	3.1
2330-157	50	3.8
2330-197	50	4.7

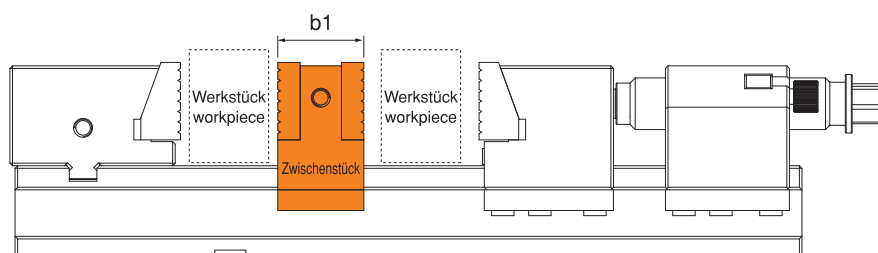
**Hinweis:** Um mehrere Werkstücke spannen zu können, werden Zwischenstücke benötigt.  
**Notes:** To be able to clamp several workpieces, intermediate pieces are required.



Referenz-Nr. Order No.	a	L	L1	b1	b	c	h	i	n	Ød	Spannkraft clamping force kgf	Drehmoment Allowable Screw Torque (N-m)	 (kg)
2345-127	127	202	260	53	0-58	60	115	163.5	55	12.5	4500	170	28





**2345**

- bestehend aus 2 beweglichen Teilen
- Werkstück wird nach unten gespannt
- Aktivflächen komplett feingeschliffen und feingehärtet

**2345**

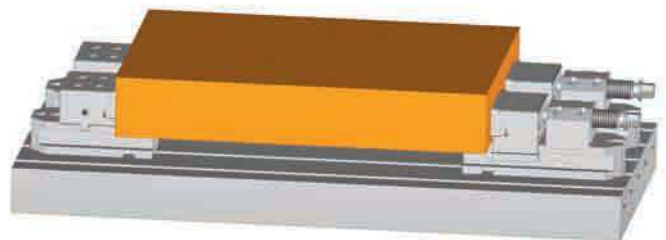
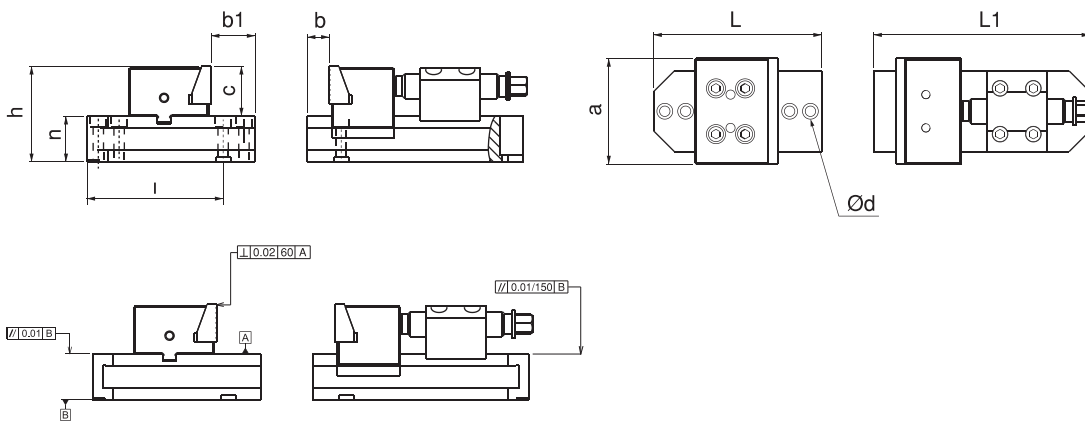
- Because of sliding clamping jaws it clamps the workpieces in opposite direction and down. The vice consists of two parts and it is parallel which provides clamping big tools, threading and similar processes easy.
- Entire moving surface is sensitively grinded and hardened.



Referenz-Nr. Order No.	a	b	c	d	e	f	
2333-127	127	45	7	-	5	-	760
2333-157	157	45	7	-	5	-	935
2333-197	197	45	7	-	5	-	1180

**2333**  
• Gehärtet

**2333**  
• Hardened

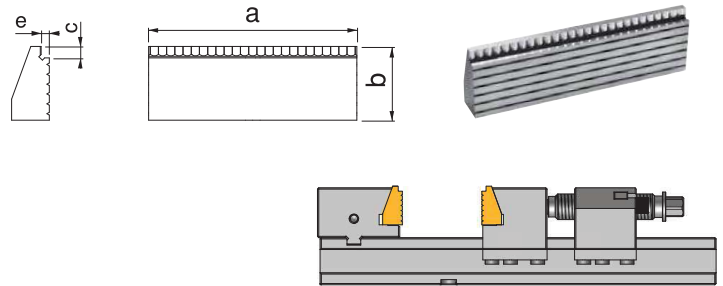

Referenz-Nr. Order No.	a	b	c	d	e	f	
2334-127	127	45	-	-	-	-	765
2334-157	157	45	-	-	-	-	960
2334-197	197	45	-	-	-	-	1185

**2334**  
• Gehärtet

**2334**  
• Hardened

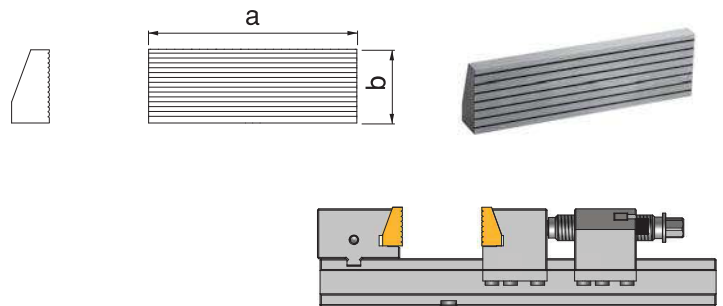

Referenz-Nr. Order No.	a	b	c	d	e	f	
2335-127	127	45	7	-	5	-	760
2335-157	157	45	7	-	5	-	935
2335-197	197	45	7	-	5	-	1180

**2335**  
• Gehärtet

**2335**  
• Hardened

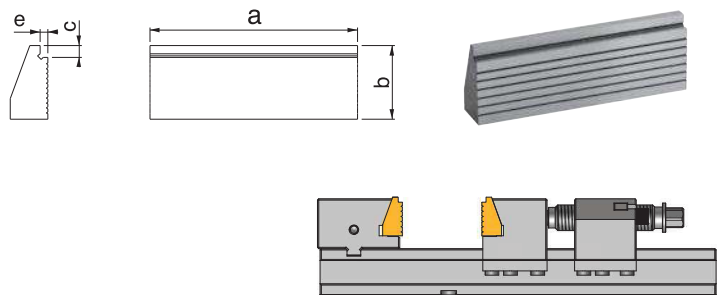

Referenz-Nr. Order No.	a	b	c	d	e	f	
2340-127	127	45	7	34	5	5	950
2340-157	157	45	7	34	5	5	1010
2340-197	197	45	7	34	5	5	1290

**2340**  
• Gehärtet

**2340**  
• Hardened

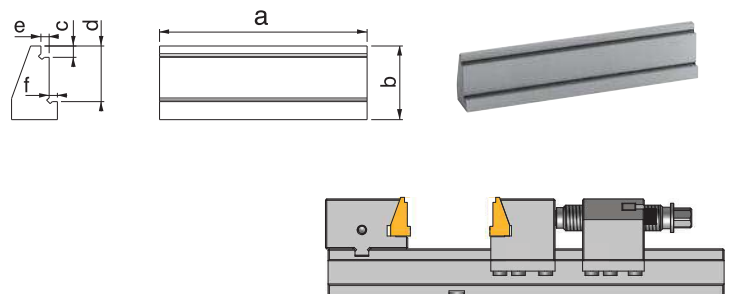

Referenz-Nr. Order No.	a	b	c	d	e	f	
2336-127	127	45	7	34	5	5	950
2336-157	157	45	7	34	5	5	1010
2336-197	197	45	7	34	5	5	1290

**2336**  
• Gehärtet

**2336**  
• Hardened

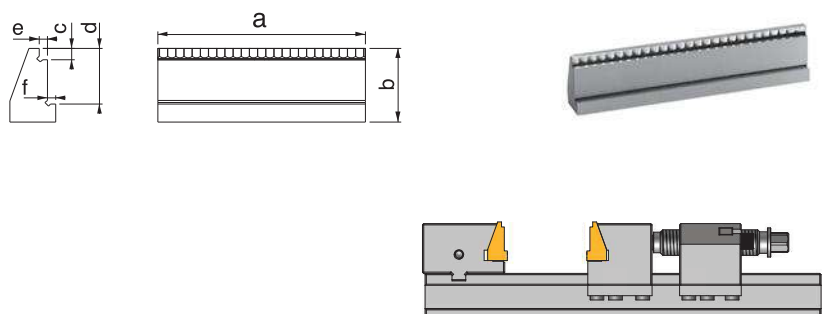



Referenz-Nr. Order No.
2330-127160AG
2330-157200AG
2330-157300AG
2330-197300AG
2330-197400AG
2330-197500AG

**2330  
Grundkörper  
Sub-body**

**Hinweis:** Um mehrere Werkstücke spannen zu können, werden Zwischenstücke benötigt.  
**Notes:** To be able to clamp several workpieces, intermediate pieces are required.

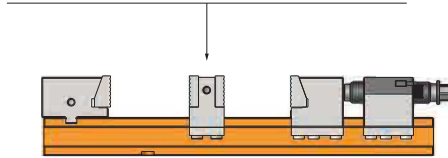

Referenz-Nr. Order No.
2330-127SÇ
2330-157SÇ
2330-197SÇ

**2330  
Fixe Backe  
Fixed Jaw**

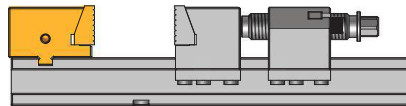

Referenz-Nr. Order No.
2330-127GÇ
2330-157GÇ
2330-197GÇ

**2330  
Bewegliche Backe  
Portable Jaw**

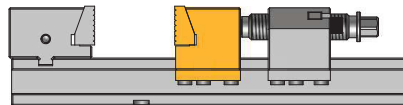

Referenz-Nr. Order No.
2330-127GS
2330-157GS
2330-197GS

**2330  
Bewegliche Mutter  
Portable nut**

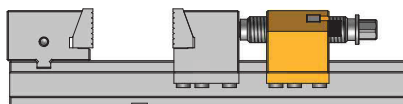

Referenz-Nr. Order No.
2330-127SK
2330-157SK
2330-197SK

**2330  
Anschlag  
Wedge of Stop**

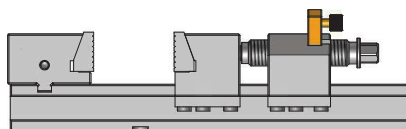

Referenz-Nr. Order No.
2330-127157197M

**2330  
Spindel  
Pin**

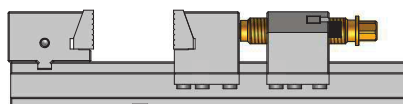

Referenz-Nr.  
Order No.  
2345-127SAG

**2345**  
**Grundkörper**  
**Fixed Sub-body**

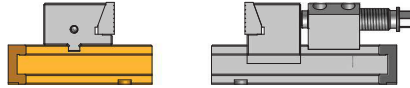

Referenz-Nr.  
Order No.  
2345-127GAG

**2345**  
**Beweglicher Grundkörper**  
**Portable Sub-body**



Referenz-Nr.  
Order No.  
2345-127SÇ

**2345**  
**Fixe Backe**  
**Fixed Jaw**



Referenz-Nr.  
Order No.  
2345-127GÇ

**2345**  
**Bewegliche Backe**  
**Portable Jaw**

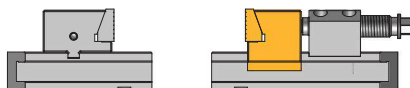

Referenz-Nr.  
Order No.  
2345-127SS

**2345**  
**Bewegliche Mutter**  
**Fixed Nut**



Referenz-Nr.  
Order No.  
2330-127157197M

**2330**  
**Spindel**  
**Pin**



Referenz-Nr. Order No.	a	b	c	k	L	d	e	h	i	n ±0.01	Spannkraft clamping force kgf	Bewegungsstanz Moving Distance Torque	(kg)
2350-160E	160	160	58	310	530	130	145	160	190	105	2000	4	62



### 2350

- 6 bar
- Spannkraft 2000 kg, verstellbar
- Verwendung: Fräsen CNC und mechanisch und sonstige Industriemaschinen
- Aktivflächen komplett feingeschliffen und feingehärtet

### 2350

- It works with 6 Bar Air. It provides speed in clamping-opening processes because of it's pneumatic structure.
- It fixes the workpiece with it's 2000 kgf clamping force. Clamping force can be adjusted with it arbitrary bar adjustment button.
- Area of Using: CNC and mechanical milling machines, drilling machines, various industrial machines
- Entire moving surface is sensitively grinded and hardened.

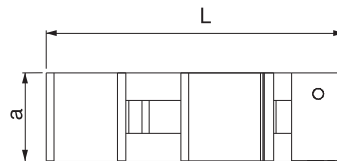
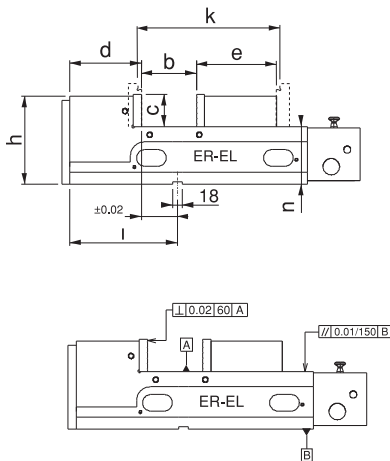

• Ersatzbacken sind nicht enthalten

• "k" measurement is reached by the spare jaws. The spare jaws are not included in the set.

Referenz-Nr. Order No.	a	a1	b	c	k	L	d	e	h	i	n ±0.01	Spannkraft clamping force kgf	Bewegungsstanz Moving Distance Torque	(kg)
2370-051	130	188	60	58	135	327	64	209	160	-	105	1100	4	37
2370-052	130	185	140	63	225	400	69	300	160	173	105	2200	4	44
2370-053	160	201	200	63	300	485	93	353	166	170	105	3300	4	63
2370-054	200	240	250	63	360	530	93	410	166	185	105	4100	4	81

# Pneumatischer Schraubstock

## Pneumatic Vice



### 2370

- 6 bar
- Spannkraft 1100 - 4100 kg, einstellbar
- Verwendung: Fräsen CNC und mechanisch und sonstige Industriemaschinen
- Aktivflächen komplett feingeschliffen und feingehärtet

### 2370

- It works with 6 Bar Air. It provides speed in clamping-opening processes because of it's pneumatic structure.
- It fixes the workpiece with it's 1100 kgf and 4100 kgf clamping force. Clamping force can be adjusted with it arbitrary bar adjustment button.
- Area of Using: CNC and mechanical milling machines, drilling machines, various industrial machines
- Entire moving surface is sensitively grinded and hardened.

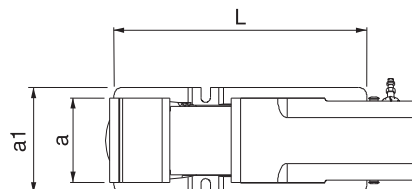
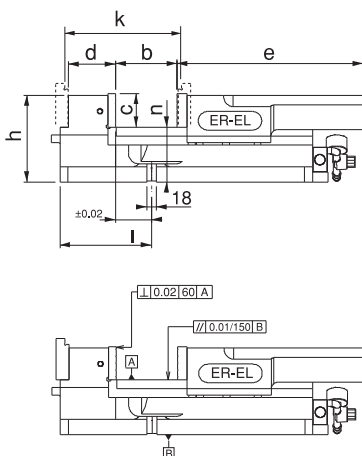

• Ersatzbacken sind nicht enthalten

• "k" measurement is reached by the spare jaws. The spare jaws are not included in the set.

### 2370-051 Detail

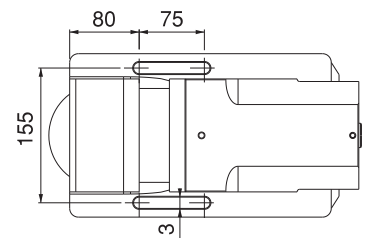

Referenz-Nr. Order No.	b	b1	b2	L	h	s	sw	Spannmenge coupling piece	Spannkraft Clamping force kgf	(kg)
2375-092	92	61	224	430	119	400	19	2	2000	44
2375-192	192	61	324	530	119	500	19	2	2000	48.7
2375-342	342	61	474	680	124	650	19	2	2000	52.5
2375-442	442	61	575	780	124	750	19	2	2000	57



### 2375

- feingeschliffen, mehrfach verwendbar
- Spannen von 1 oder mehreren Werkstücken mit einer Bewegung
- Aktivflächen komplett feingeschliffen und feingehärtet

### 2375

- It is fine ground. As figures below it is multifunctional. It is designed for clamping 1 or more than one workpieces with only 1 tool motion.
- Entire moving surface is sensitively grinded and hardened.

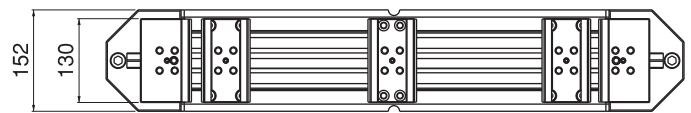
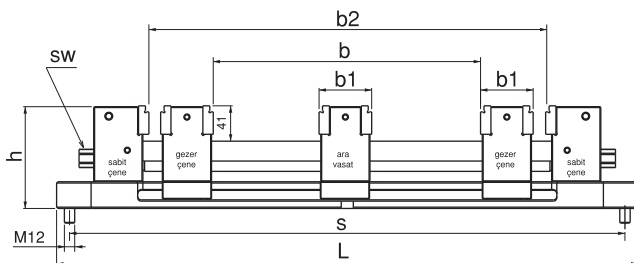

Referenz-Nr. Order No.	Spannmengen / Volume Workholding				
	1 Werkstück 1 Workpiece	2 Werkstück 2 Workpiece	3 Werkstück 3 Workpiece	4 Werkstück 4 Workpiece	5 Werkstück 5 Workpiece
2375-092	92	15	-	-	-
2375-192	192	66	23	-	-
2375-342	342	140	73	39.5	-
2375-442	442	190	106.5	64.5	39

### Eigenschaft: Alle Anwendungen mit einer Bewegung spannen / All applications feature a single motion-Tightening

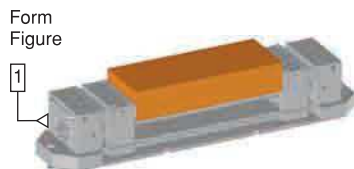

Spannen 1 Werkstück  
Figure clamping 1 piece



Spannen empfindlicher  
Teile auf Parallelen  
Figure clamping thin workpiece  
on motion parallels

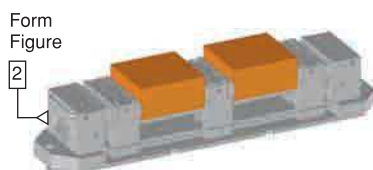

Spannen 2 Werkstücke  
Figure clamping 2 peaces



Mehrfachspannen  
Figure multiple clamping



Konstante Backen,  
vom Zentrum nach außen spannen  
Figure based on fixed jaw clamping  
from centre in outward



Spannen mit Weichbacken  
Figure clamping with soft legs

# Schraubstock Anwendung

*Vise Applications*





Referenz-Nr. Order No.	d	d1	h	h1	L	(kg)
2385-130	48	32	91	60	151	3.05



### 2385

- Präzision 0,01 Bearbeitung Durchmesser 9-130 mm und Tiefe 170 mm

### 2385

- It works with 0.01 sensitivity in diameter 9-130 mm and 145 mm depth. Because of replaceable function kater and cartouche it is perfect in using.

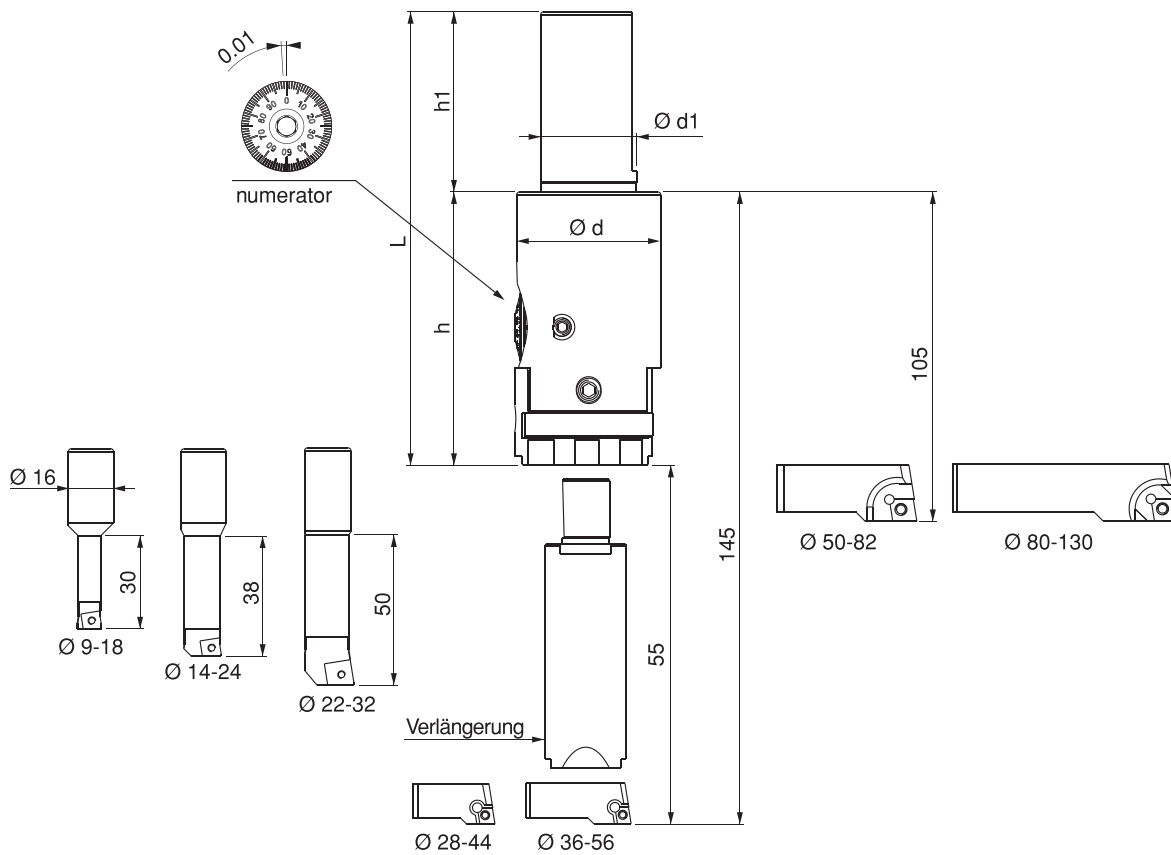

Hinweis :  
ab 52 mm Durchmesser  
kann mit dem  
Grundkörper 105 mm  
Tiefe und mit Verlängerung  
eine Tiefe von 145 mm  
erreicht werden

Referenz-Nr. Order No.	Type	Einsatz-Type Type of Inserts	Rotation	Progress	ap
2386-00918	09-18 Einsatz	CCMT 06	2700 d/dk.	F 75	0.1 - 0.5 mm
2386-01424	14-24 Einsatz	CCMT 06	2500 d/dk.	F 75	0.1 - 0.5 mm
2386-02232	22-32 Einsatz	CCMT 09	2000 d/dk.	F 50	0.1 - 1 mm
2386-02844	28-44 Kartusche	CCMT 06	1800 d/dk.	F 60	0.1 - 1 mm
2386-03656	36-56 Kartusche	CCMT 06	1500 d/dk.	F 65	0.1 - 1.5 mm
2386-05082	50-82 Kartusche	CCMT 09	1500 d/dk.	F 70	0.1 - 2 mm
2386-80130	80-130 Kartusche	CCMT 09	360 d/dk.	F 75	2 mm
2386-00055	Verlängerung	-	400 d/dk.	F 75	1.5 mm

Note; from diameter 52: It reaches 105 mm depth with its slot and 145 mm depth with its extended kater

Referenz-Nr. Order No.	J x M	k	h	h1	e	L	L1	L2	
2390-010	ISO30-M12	83	99	35	18	85	128	26	6030
2390-015	ISO40-M16								6555
2390-020	ISO50-M24								9110
2390-025	BT40 -M16								6900
2390-030	BT50 - M24								9840
2390-035	SK40- M16								6750
2390-040	SK50- M24					8970			
2390-045	MK4 - M16					6180			
2390-050	MK4 Keil / wedge					6880			
2390-055	MK5 - M20					7785			
2390-060	MK5 Keil / wedge					7450			

### 2390

- Präzision 0,01 Bearbeitung 18-210 mm  
beinhaltet 4 Locheinsätze und 1 Nutenräumer in Holzkiste  
wechselbare Einsätze: ISO 30-40; BT 40-50; SK40-50; MK4-5

### 2390

- Product has 0.02 machining sensitivity and it can implement processes from 18mm to 210mm.  
It's modular system structure provides convenience in using.  
It provides the possibility of using in CNC and Mechanical benches by changing the holder.  
The product takes place in a wooden box with it's 4 hole bar, 1 T-Slot scraper.  
Changeable Holders:  
Possibility to be used with ISO30-40-50 BT 40-50 SK40-50 MK4-5.

Referenz-Nr. Order No.	L	L1	e	Kanten Schneid-Typ Cutting Edge type	
2395-1	85	-	18	DCMT	112
2395-2	95	-	18	DCMT	130
2395-3	132	-	18	DCMT	200
2395-4	-	128	18	-	360

min	Ø	max	c1	Umdrehung / Min Revolution per minute
18		95	50	400-450
18		95	63	400-450
20		100	100	170-220

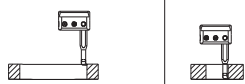

- Bei Montage der Einsätze ist Bearbeitung 18-100 mm Durchmesser und 0-100 mm Tiefe möglich
- It is possible to have enlargement from 18mm to 100mm by attaching bars to the bottom holes taking place in the slide of the product and it can go down to depth up to 0-100mm.

min	Ø	max	c2	Umdrehung / Min Revolution per minute
95		210	55	90-170
95		210	65	90-170



- Bei Montage der Zwischeneinsätze ist Bearbeitung Durchmesser 95-210 mm und Tiefe 0-65 mm möglich
- By applying intermediary means to the side hole of the product's slide, it is possible to have enlargement from 95mm to 210mm and it can go down to depth up to 0-65mm as seen in the figure.



Es ist modular aufgebaut.  
Befestigung erfolgt durch im Uhrzeigersinn in den Prozess zu schrauben.

It is modular. Fixing process is done screwing towards clockwise

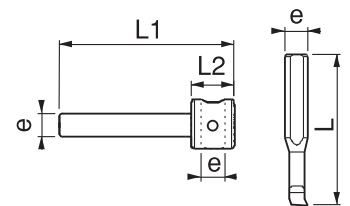
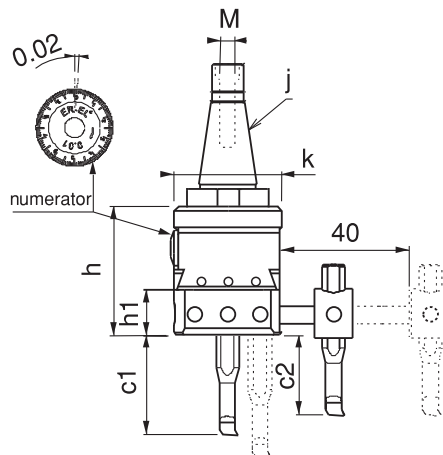
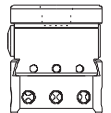
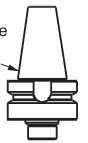

Referenz-Nr. Order No.	ISO	d	d1	L	L1	m	
2410-3016	ISO 30	16	48	125	17	M12	665
2410-3022	ISO 30	22	48	125	19	M12	760
2410-3027	ISO 30	27	48	125	21	M12	790
2410-3032	ISO 30	32	63.5	125	22	M12	1020
2410-4016	ISO 40	16	63.5	153	17	M16	1170
2410-4027	ISO 40	27	63.5	153	19	M16	1360
2410-4032	ISO 40	32	63.5	153	24	M16	1605
2410-4040	ISO 40	40	73.5	153	27	M16	1795
2410-5016	ISO 50	16	98	195	17	M24	3250
2410-5022	ISO 50	22	98	195	19	M24	3350
2410-5027	ISO 50	27	98	195	21	M24	3400
2410-5032	ISO 50	32	98	195	24	M24	3590
2410-5040	ISO 50	40	98	195	27	M24	3750

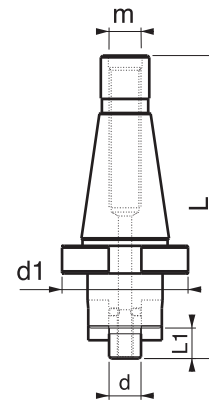

#### 2410 ISO 30-40-50

- Gehärtet
- Fein geschliffen

#### 2410 ISO 30-40-50

- Hardened
- Sensitive Grinding

Referenz-Nr. Order No.	MK	d	d1	L	L1	m	
2415-0416	MK 4	16	40	168	17	M16	945
2415-0422	MK 4	22	48	168	19	M16	1010
2415-0427	MK 4	27	53	168	21	M16	1135
2415-0432	MK 4	32	63.5	168	24	M16	1255
2415-0516	MK 5	16	63.5	208	17	M20	2145
2415-0522	MK 5	22	63.5	208	19	M20	2375
2415-0527	MK 5	27	63.5	208	21	M20	2360
2415-0532	MK 5	32	63.5	208	24	M20	2500
2415-0540	MK 5	40	73.5	208	27	M20	2700

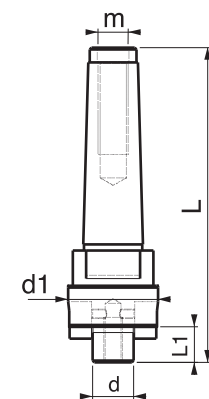

#### 2415 MK4-MK5

- Gehärtet
- Fein geschliffen

#### 2415 MK4-MK5

- Hardened
- Sensitive Grinding

Referenz-Nr. Order No.	d	h	d1	p	e		Kanten Schneid-Typ Cutting Edge type	
2420-0403	40	44	16	8.5	16	3	TPKN	230
2420-0503	50	44	22	10.5	16	3	TPKN	310
2420-0633	63	44	22	10.5	16	3	TPKN	410
2420-0634	63	44	22	10.5	16	4	TPKN	480
2420-0804	80	52	32	14.5	22	4	TPKN	800
2420-1005	100	52	32	14.5	22	5	TPKN	1320

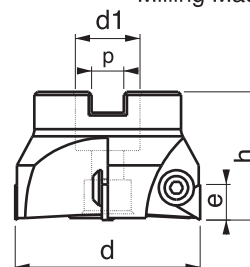

#### 2420

- Gehärtet
- Schwarz beschichtet

#### 2420

- Hardened
- Black Coating

Referenz-Nr. Order No.	d	Gewinde Thread	Allen
2420-06	40-50-63	M6x0.75	4
2420-08	80-100	M8x1	5



#### 2420

- Gehärtet
- Schwarz beschichtet

#### 2420

- Hardened
- Black Coating

# Montage und unterschiedliche Anwendungen

*Mounting and Various Applications*

## Mehrfachspanner eine Richtung

One Direction Clamping of Multi Jawed Wrench Tooling

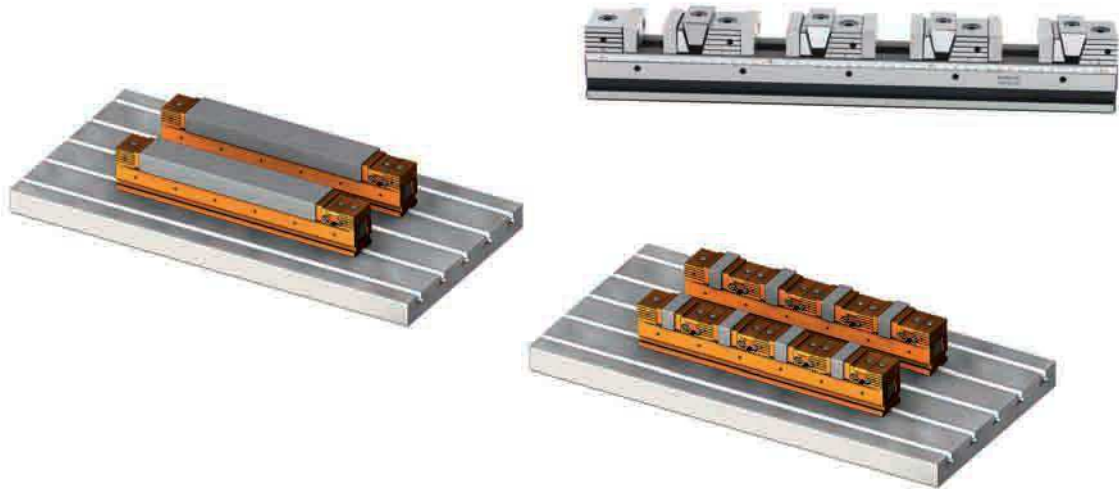

## Mehrfachspanner beide Richtungen

Two Direction Clamping of Multi Jawed Wrench Tooling

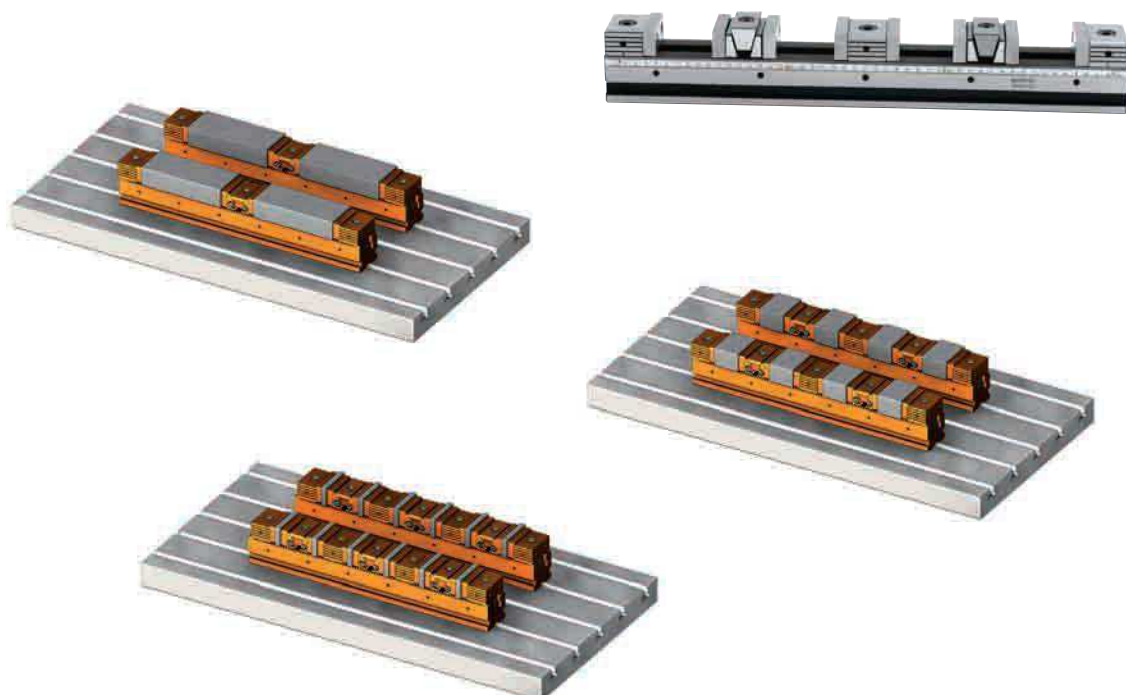

Referenz-Nr. Order No.	L	n	h1	h2	h	o	e	f	b	c	k	i	p H7	Spannmenge Coupling Piece	Spannkraft clamping force kgf	Drehmoment Allowable Screw Torque (N-m)	(kg)
2430-055300	300	55	50	32	72	12.5	36	65	100	50	100	100	18	2	1750	25	9
2430-055500	500	55	50	32	72	12.5	36	65	100	50	100	300	18	4			15
2430-075400	400	75	65	37	102	12.5	48	77	100	50	100	200	18	2	2000	35	20
2430-075600	600	75	65	37	102	12.5	48	77	100	50	100	400	18	4			33
2430-100400	400	100	65	37	102	12.5	48	80	100	50	100	200	18	2	2500	50	27
2430-100600	600	100	65	37	102	12.5	48	80	100	50	100	400	18	3			41



### 2430

- Spannen mehrer Werkstücke möglich
- Formanpassung möglich
- Feinbeschichtung
- Backen müssen separat bestellt werden.

### 2430

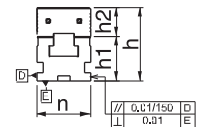
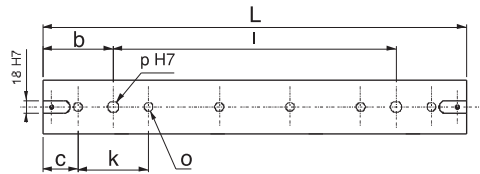
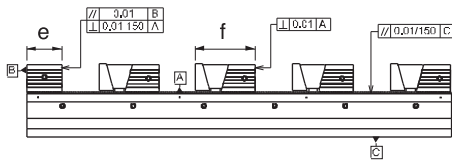
- It provides the attachments of more than one workpieces to the product. Jaws are modular and can be adjusted to the desired measurement.
- Form of the workpiece can be applied on the soft legs connected to the groups.
- Sensitive Grinding
- You need to purchase jaws separate.

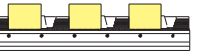
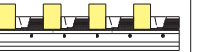
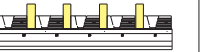

Referenz-Nr. Order No.	Spannmengen / Numbers of Portable Jaw with Workpiece Couplings				
	1 Werkstück 1 Workpiece	2 Werkstück 2 Workpiece	3 Werkstück 3 Workpiece	4 Werkstück 4 Workpiece	5 Werkstück 5 Workpiece
2430-055300					
2430-055300	196mm	65mm	22mm	-	-
2430-055500	394mm	165mm	88mm	50mm	26mm
2430-075400	268mm	95mm	38mm	-	-
2430-075600	472mm	197mm	106mm	60mm	32mm
2430-100400	265mm	93mm	35mm	-	-
2430-100600	469mm	195mm	103mm	57mm	30mm

**Hinweis:** Bei den Werkstückmaßen sind die weichen Backen nicht inkludiert. **Note:** It does not include binding units of measure soft feet in business.





Referenz-Nr. Order No.	L	n	h1	h2	h	o	e	f	b	c	k	i	p H7	Spannkraft Clamping Force Kgf	Drehmoment Allowable Screw Torque (N-m)
2435-055300	300	55	50	32	82	12.5	32	37	100	50	100	100	18	1750	25
2435-055500	500	55	50	32	82	12.5	32	37	100	50	100	300	18		
2435-075400	400	75	65	37	102	12.5	37	57	100	50	100	200	18	2000	35
2435-075600	600	75	65	37	102	12.5	37	57	100	50	100	400	18		
2435-100400	400	100	65	37	102	12.5	37	57	100	50	100	200	18	2500	50
2435-100600	600	100	65	37	102	12.5	37	57	100	50	100	400	18		

### 2435

- Spannt doppelseitig
- Backen müssen separat bestellt werden.

### 2435

- Double Opening
- You need to purchase jaws separate.

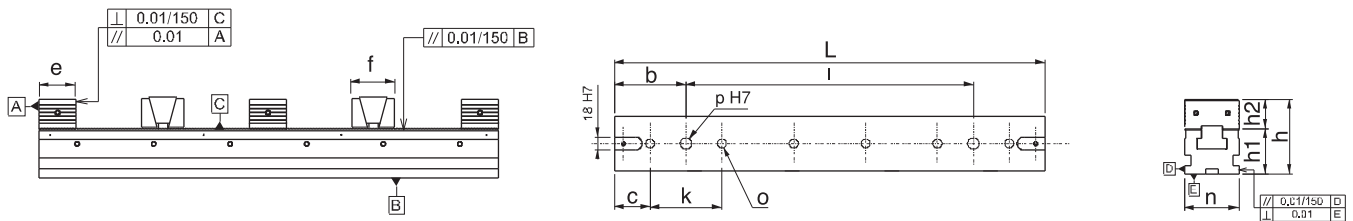

Referenz-Nr. Order No.	Spannmengen / Numbers of Double Opening Jaw with Workpiece Couplings		
	2 Werkstück 2 Workpiece	3 Werkstück 3 Workpiece	4 Werkstück 4 Workpiece
2435-055300	75mm	37mm	16mm
2435-055500	173mm	103mm	66mm
2435-075400	107mm	55mm	28mm
2435-075600	209mm	123mm	79mm
2435-100400	104mm	53mm	26mm
2435-100600	206mm	121mm	77mm
	5 Werkstück 5 Workpiece	6 Werkstück 6 Workpiece	7 Werkstück 7 Workpiece
2435-055300	-	-	-
2435-055500	45mm	30mm	20mm
2435-075400	13mm	-	-
2435-075600	54mm	45mm	24mm
2435-100400	12mm	-	-
2435-100600	52mm	34mm	22mm

**Hinweis:** Bei den Werkstückmaßen sind die weichen Backen nicht inkludiert.

**Note:** It does not include binding units of measure soft feet in business.



Referenz-Nr. Order No.	a	b	c
2430-24350551	55	14	34
2430-24350751	75	14	39
2430-24351001	100	14	39

- Gehärtet
- Vernickelt
- Hardened
- Nickel Coating

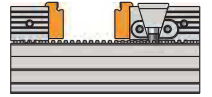
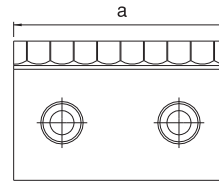
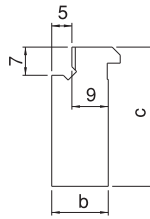

Referenz-Nr. Order No.	a	b	c
2430-24350552	53	14	34
2430-24350752	73	14	39
2430-24351002	98	14	39

- Gehärtet
- Vernickelt
- Hardened
- Nickel Coating

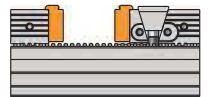
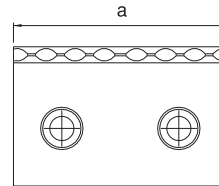
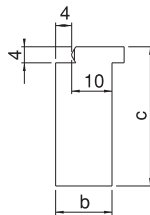

Referenz-Nr. Order No.	a	b	c	d
2430-24350553	53	22	34	17
2430-24350753	73	25	39	20
2430-24351003	98	25	39	20

- Gehärtet
- Vernickelt
- Hardened
- Nickel Coating

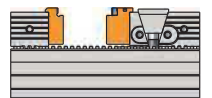
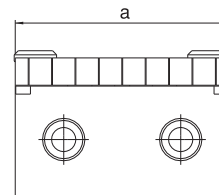
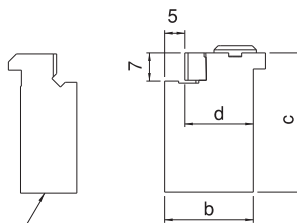

2430-24350551  
2430-24350751  
2430-24351001

Referenz-Nr. Order No.	a	b	c
2430-24350554	53	19	34
2430-24350754	73	19	39
2430-24351004	98	19	39

- Gehärtet
- Vernickelt
- Hardened
- Nickel Coating

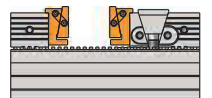
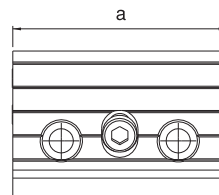
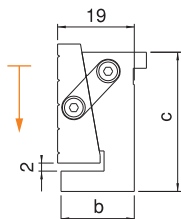

Referenz-Nr. Order No.	a	b	c
2430-24350555	53	14	34
2430-24350755	73	14	39
2430-24351005	98	14	39

- Weiche Backen für Mehrfachspanner**  
**Serial Vice Soft Jaw**

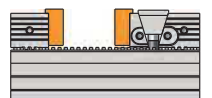
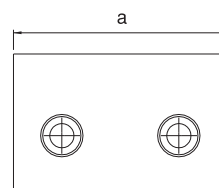
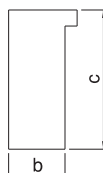

Referenz-Nr. Order No.	a	b	c
2430-2435055300AG	55	300	50
2430-2435055500AG	55	500	50
2430-2435075400AG	75	400	65
2430-2435075600AG	75	600	65
2430-2435100400AG	100	400	65
2430-2435100600AG	100	600	65

**Mehrfachspanner Grundkörper**  
Serial Vice Sub-Body

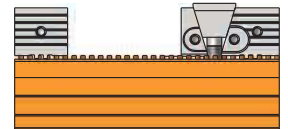
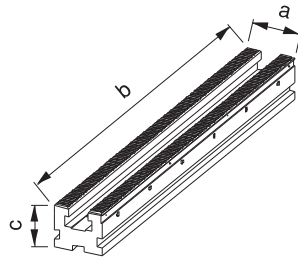

Referenz-Nr. Order No.	a	b	c
2430-2435055GÇ	54	65	32
2430-2435075GÇ	74	77	37
2430-2435100GÇ	99	80	37

**Mehrfachspanner bewegliche Backe**  
Serial Vice Portable Jaw

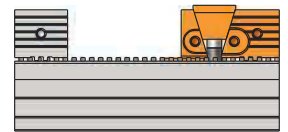
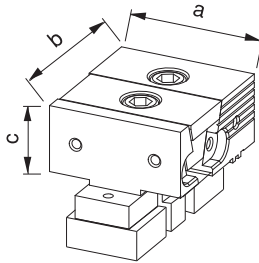

Referenz-Nr. Order No.	a	b	c
2430-2435055DA	54	36	32
2430-2435075DA	74	48	37
2430-2435100DA	99	48	37

**Mehrfachspanner feste Backe**  
Serial Vice Resting

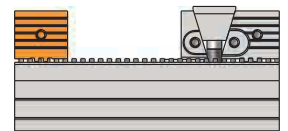
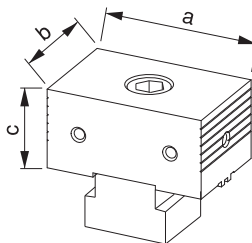

Referenz-Nr. Order No.	a	b	c
2430-2435055ÇA	54	36	32
2430-2435075ÇA	74	48	37
2430-2435100ÇA	99	48	37

**Keilspanner**  
Serial Vice Double Opening

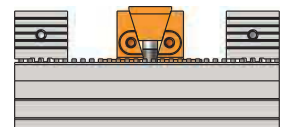
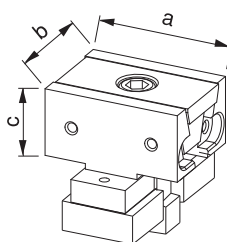

# Das modulare Mehrfachspannsystem

*Serial Vice*

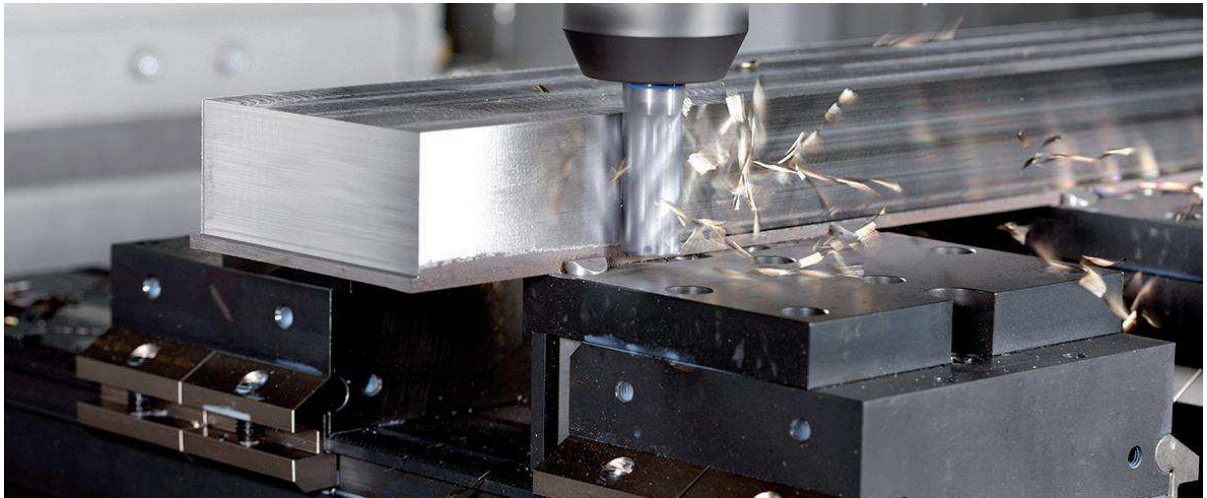

Referenz-Nr. Order No.	a	b	c	d
2440-SL080400	35	400	80	0-289
2440-SL080500	35	500	80	0-389
2440-SL080600	35	600	80	0-489

2440

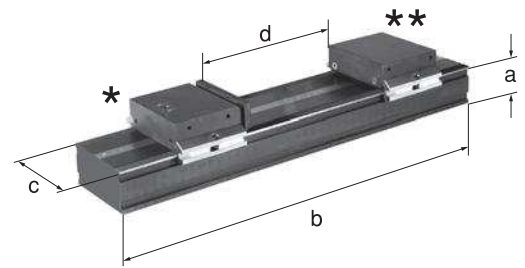

**bewegliche Backen / Portable Jaw Types**



**Stütze / Stopper Types**



**Das modulare Mehrfachspannsystem**

Referenz-Nr. Order No.	a	b	c	d
2440-SL120300	60	300	120	0-90
2440-SL120600	60	600	120	0-390
2440-SL120800	60	800	120	0-590

2440

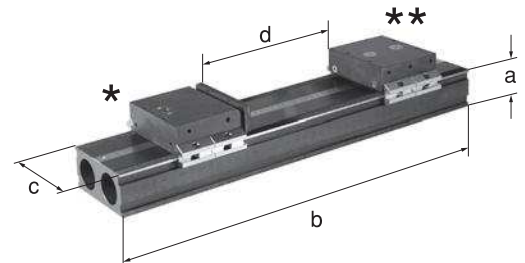

**bewegliche Backen / Portable Jaw Types**



**Stütze / Stopper Types**



**Werkstückanschlag fest**

Referenz-Nr. Order No.
2440-SL80120

2440





Referenz-Nr. Order No.	L	n	n1	h	h1	h2	o	e	f	a	b	c	k	i	p H7	Spannmenge Coupling Piece	Stroke	Spannkraft Clamping Force Kgf
2443-055300	300	125	55	148	105	43	12.5	38	81.5	100	50	100	100	200	18	1	8	750
2443-055500	500	125	55	148	105	43	12.5	38	81.5	100	100	150	200	300	18	2	8	750
2443-075400	400	175	75	158	115	43	12.5	48	88	150	50	100	200	300	18	2	8	1100
2443-075600	600	175	75	158	115	43	12.5	48	88	150	100	150	300	400	18	-	8	1100
2443-100400	400	175	100	158	115	43	12.5	48	88	150	50	100	200	300	18	2	8	1100
2443-100600	600	175	100	158	115	43	12.5	48	88	150	100	150	300	400	18	-	8	1100

### 2443

- Bitte geben Sie vor dem Kauf die Anzahl der zu spannenden Werkstücke an.
- Backen müssen separat bestellt werden.

### 2443

- Please, you specify about number of clamping before you make purchase.
- You need to purchase jaws separate.

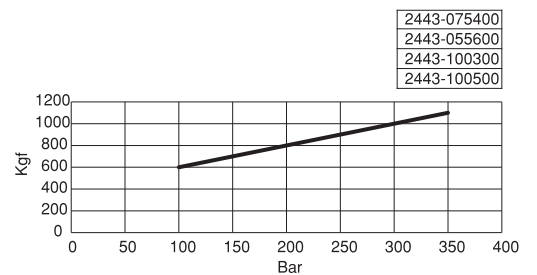
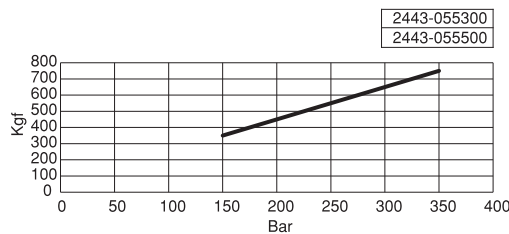
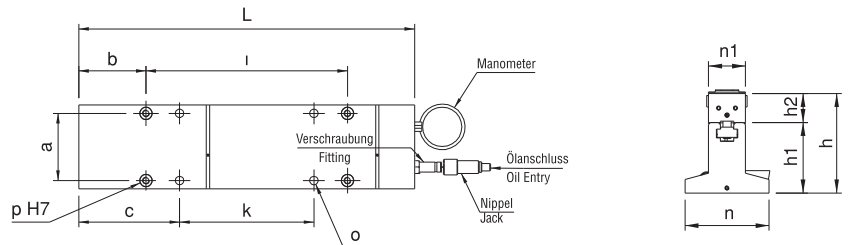
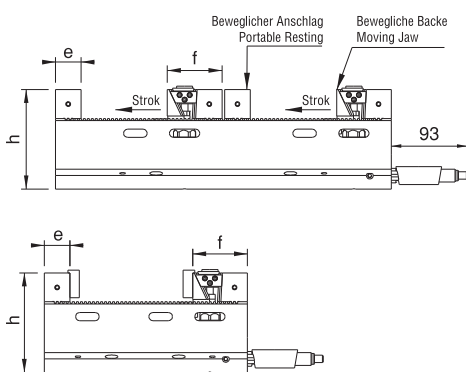
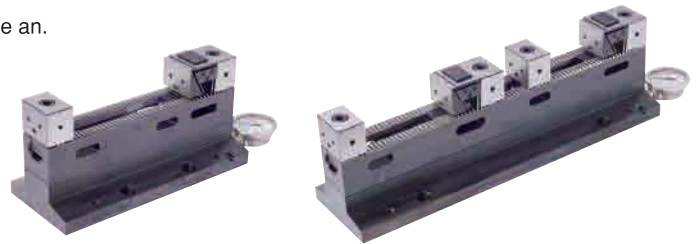

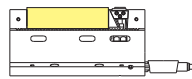
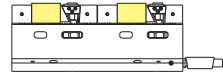
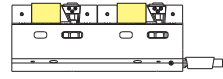
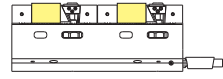
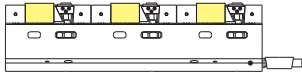
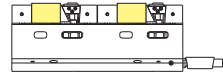
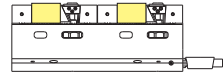
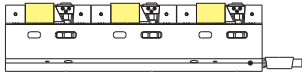
Referenz-Nr. Order No.	Spannmengen / Numbers of Portable Jaw with Workpiece Couplings		
	1 Werkstück 1 Workpiece	2 Werkstück 2 Workpiece	3 Werkstück 3 Workpiece
2443-055300	 182 mm	-	-
2443-055500	-	 128 mm	-
2443-075400	-	 68 mm	-
2443-075600	-	 170 mm	 68 mm
2443-100400	-	 68 mm	-
2443-100600	-	 170 mm	 68 mm

**Hinweis:** Bei den Werkstückmaßen sind die weichen Backen nicht inkludiert.

**Note:** It does not include binding units of measure soft feet in business.





Referenz-Nr. Order No.	L	n	n1	h	h1	h2	o	e	f	a	b	c	k	i	p H7	Spannmenge Coupling Piece	Stroke	Spannkraft Clamping Force Kgf
2445-055300	300	125	55	148	105	43	12.5	38	51.5	100	50	100	100	200	18	2	8x2	750
2445-055500	500	125	55	148	105	43	12.5	38	51.5	100	100	150	200	400	18	4	8x2	750
2445-075400	400	175	75	158	115	43	12.5	48	51.5	150	50	100	200	300	18	2	8x2	1100
2445-075600	600	175	75	158	115	43	12.5	48	51.5	150	100	150	300	500	18	4	8x2	1100
2445-100400	400	175	100	158	115	43	12.5	48	51.5	150	50	100	200	300	18	2	8x2	1100
2445-100600	600	175	100	158	115	43	12.5	48	51.5	150	100	150	300	500	18	4	8x2	1100

### 2445

• Backen müssen separat bestellt werden.

### 2445

• You need to purchase jaws separate.

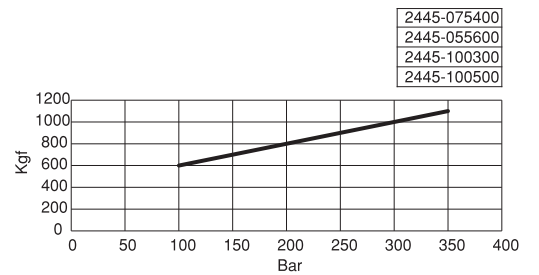
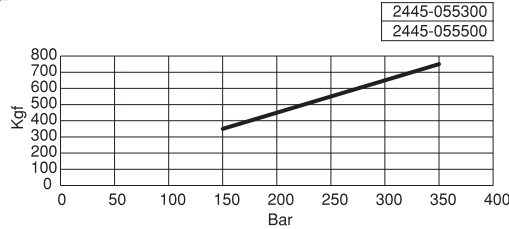
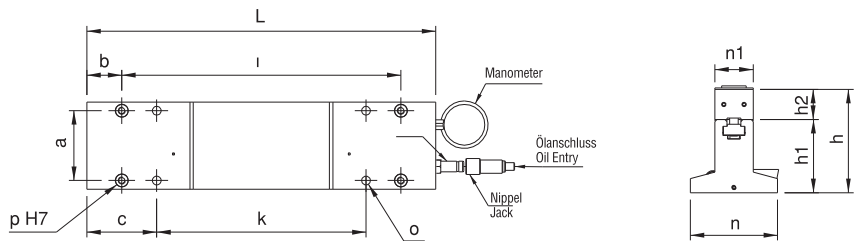
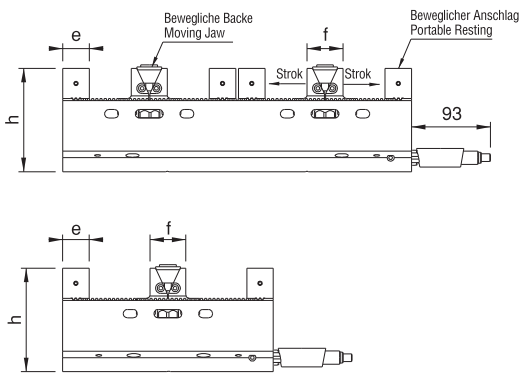

Referenz-Nr. Order No.	Spannmengen Numbers of Double Opening Jaw with Workpiece Couplings	
	2 Werkstück 2 Workpiece	4 Werkstück 4 Workpiece
2445-055300	87 mm	-
2445-055500	-	60 mm
2445-075400	125 mm	-
2445-075600	-	75 mm
2445-100400	125 mm	-
2445-100600	-	75 mm

**Hinweis:** Bei den Werkstückmaßen sind die weichen Backen nicht inkludiert.

**Note:** It does not include binding units of measure soft feet in business.



Referenz-Nr. Order No.	a	b	c
2443-24450551	55	14	38
2443-24450751	75	14	38
2443-24451001	100	14	38

- Gehärtet • Hardened
- Vernickelt • Nickel Coating

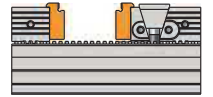
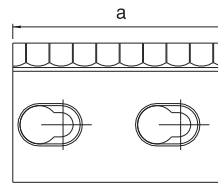
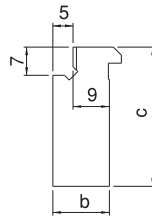

Referenz-Nr. Order No.	a	b	c
2443-24450552	55	14	38
2443-24450752	75	14	38
2443-24451002	100	14	38

- Gehärtet • Hardened
- Vernickelt • Nickel Coating

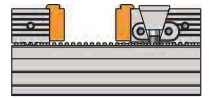
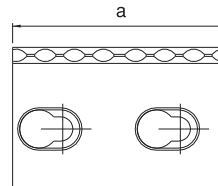
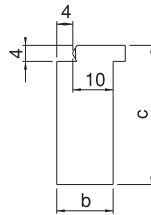

Referenz-Nr. Order No.	a	b	c	d
2443-24450553	55	22	38	17
2443-24450753	75	25	38	20
2443-24451003	100	25	38	20

- Gehärtet • Hardened
- Vernickelt • Nickel Coating

2443-24450551  
2443-24450751  
2443-24451001

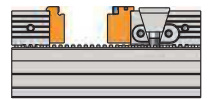
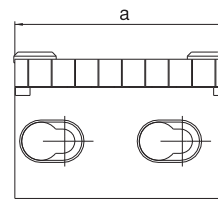
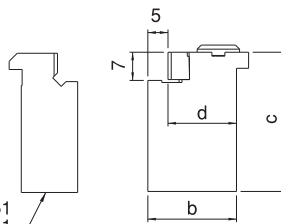

Referenz-Nr. Order No.	a	b	c
2443-24450554	55	19	38
2443-24450754	75	19	38
2443-24451004	100	19	38

- Gehärtet • Hardened
- Vernickelt • Nickel Coating

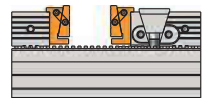
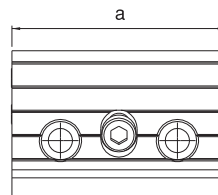
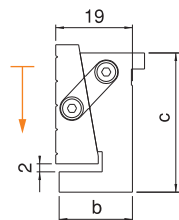

Referenz-Nr. Order No.	a	b	c
2443-24450555	55	14	38
2443-24450755	75	14	38
2443-24451005	100	14	38

### Weiche Backe Soft Jaw

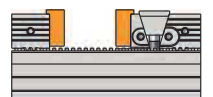
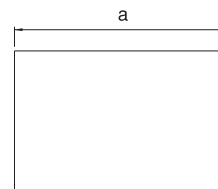
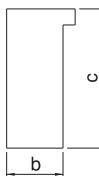

Referenz-Nr. Order No.	a	b	c
2443-24450556	55	14	38
2443-24450756	75	14	38
2443-24451006	100	14	38

### Weiche Backe Soft Jaw

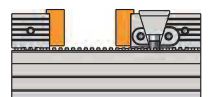
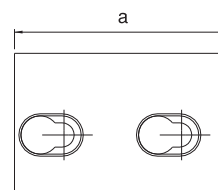
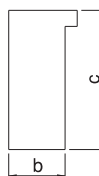

Referenz-Nr. Order No.	a	b	c	e
2443-055300AG	55	300	105	125
2443-055500AG	55	500	105	125
2443-075400AG	75	400	115	175
2443-075600AG	75	600	115	175
2443-100400AG	100	400	115	175
2443-100600AG	100	600	115	175

**Hydraulischer Grundkörper**  
**Hydraulic Sub-body**

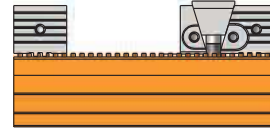
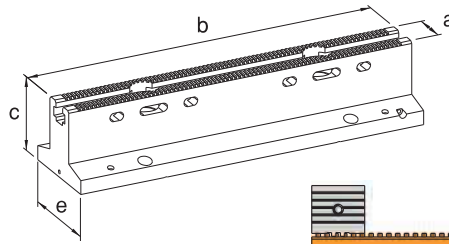

Referenz-Nr. Order No.	a	b	c
2443-055HÇ	55	81.5	43
2443-075HÇ	75	88	43
2443-100HÇ	100	88	43

**Bewegliche Backe**  
**Moving Jaw**

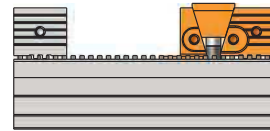
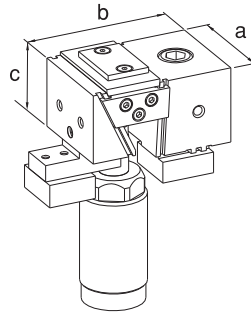

Referenz-Nr. Order No.	a	b	c
2443-055MHÇ	55	81.5	43
2443-075MHÇ	75	88	43
2443-100MHÇ	100	88	43

**Magnetische bewegliche Backe**  
**Moving Jaw**

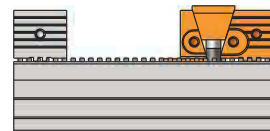
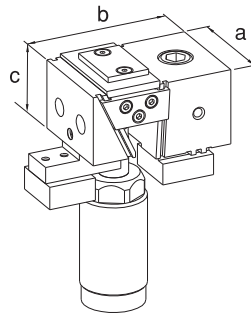

Referenz-Nr. Order No.	a	b	c
2443-2445055GD	55	38	43
2443-2445075GD	75	48	43
2443-2445100GD	100	48	43

**Beweglicher Anschlag**  
**Portable Resting**

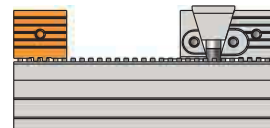
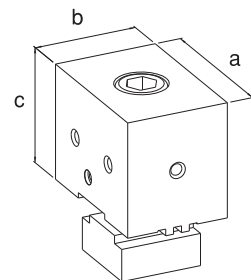

Referenz-Nr. Order No.	a	b	c
2443-2445055MGD	55	38	43
2443-2445075MGD	75	48	43
2443-2445100MGD	100	48	43

**Magnetischer beweglicher Anschlag**  
**Magnetic Portable Resting**

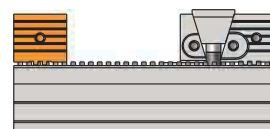
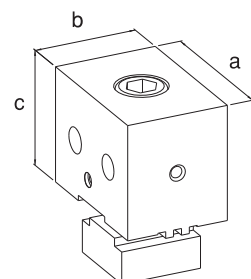

Referenz-Nr. Order No.	a	b	c	e
2445-055300AG	55	300	105	125
2445-055500AG	55	500	105	125
2445-075400AG	75	400	115	175
2445-075600AG	75	600	115	175
2445-100400AG	100	400	115	175
2445-100600AG	100	600	115	175

**Hydraulischer Grundkörper**  
**Hydraulic Sub-body**

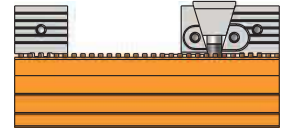
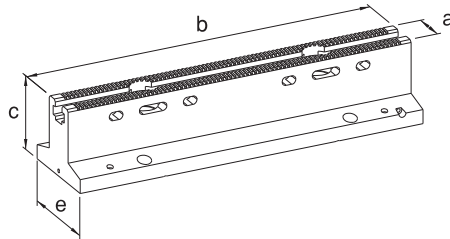

Referenz-Nr. Order No.	a	b	c
2445-055HÇ	55	51.5	43
2445-075HÇ	75	51.5	43
2445-100HÇ	100	51.5	43

**Bewegliche Backe**  
**Moving Jaw**

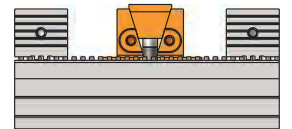
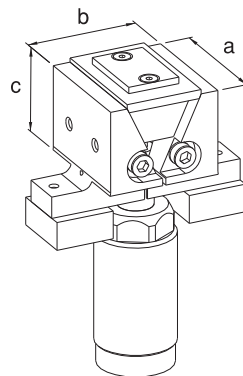

Referenz-Nr. Order No.	a	b	c
2445-055MHÇ	55	51.5	43
2445-075MHÇ	75	51.5	43
2445-100MHÇ	100	51.5	43

**Magnetische bewegliche Backe**  
**Moving Jaw**

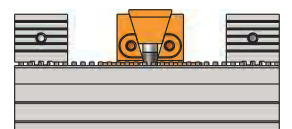
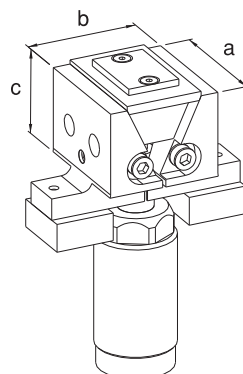

# Hydraulisches Zubehör

*Hydraulic Equipment*

