

Referans Nr.	a	m	h		s	s1	e1	d	SW		L	e	b	c	Sıkma Kuvveti Clamping Force Kgf	Nm	g
			min	max													
1160-222 T	22	M20	20	80	17-92	41.5	175	M24	12	24	178	55	74	24	5500	200	9030
1160-224 T	24	M20	20	80	17-92	41.5	175	M24	12	24	178	55	74	24	5500	200	9120
1160-228 T	28	M24	20	80	17-92	41.5	175	M24	12	24	178	55	74	24	5500	200	9180
1160-236 T	36	M24	20	80	17-92	41.5	175	M24	12	24	178	55	74	24	5500	200	9600
1160-222 LT	22	M20	20	80	25-148	41.5	175	M24	12	24	256	55	74	24	5500	280	12110
1160-224 LT	24	M20	20	80	25-148	41.5	175	M24	12	24	256	55	74	24	5500	280	12210
1160-228 LT	28	M24	20	80	25-148	41.5	175	M24	12	24	256	55	74	24	5500	280	12270
1160-236 LT	36	M24	20	80	25-148	41.5	175	M24	12	24	256	55	74	24	5500	280	12310
1165-222 T	22	M20	30	80	34-92	41.5	194	M24	12	24	205	55	85	24	10000	270	11820
1165-224 T	24	M20	30	80	34-92	41.5	194	M24	12	24	205	55	85	24	10000	270	11900
1165-228 T	28	M24	30	80	34-92	41.5	194	M24	12	24	205	55	85	24	10000	270	11960
1165-236 T	36	M24	30	80	34-92	41.5	194	M24	12	24	205	55	85	24	10000	270	12000

Ürün Nr. 1160-(T) Kızaklı Kombine Bağlama Pabucu

- (a) 22-36 T-Kanalda M20-M24 imbus civata DIN 508 T-Pabuçla kullanılır.
- Parça yükseklik sıkma aralığı 20-80mm.
- İleri-geri hareket mesafesi 75mm'dir. Sıkma Kuvveti 5500 kgf.

Ürün Nr. 1160-(LT) Kızaklı Kombine Bağlama Pabucu

- (a) 22-36 T-Kanalda M20-M24 imbus civata DIN 508 T-Pabuçla kullanılır.
- Parça yükseklik sıkma aralığı 20-80mm.
- İleri-geri hareket mesafesi 123mm'dir. Sıkma Kuvveti 5500 kgf.

Ürün Nr. 1165-(T) Kızaklı Kombine Bağlama Pabucu

- (a) 22-36 T-Kanalda M20-M24 imbus civata DIN 508 T-Pabuçla kullanılır.
- Parça yükseklik sıkma aralığı 30-80mm.
- İleri-geri hareket mesafesi 58mm'dir. Sıkma Kuvveti 10000 kgf.

Product Nr. 1160-(T) Combined Sliding Clamp

- (a) 22-36 is used in T-Slot and M20-M24 imbus bolt is used with DIN 508 T-Nut.
- Height clamping gap of the piece is 20-80mm.
- Back and forth movement distance is 75mm. Clamping force is 5500 kgf.

Product Nr. 1160-(LT) Combined Sliding Clamp

- (a) 22-36 is used in T-Slot and M20-M24 imbus bolt is used with DIN 508 T-Nut.
- Height clamping gap of the piece is 20-80mm.
- Back and forth movement distance is 123mm. Clamping force is 5500 kgf.

Product Nr. 1165-(T) Combined Sliding Clamp

- (a) 22-36 is used in T-Slot and M20-M24 imbus bolt is used with DIN 508 T-Nut.
- Height clamping gap of the piece is 30-80mm.
- Back and forth movement distance is 58mm. Clamping force is 10000 kgf.

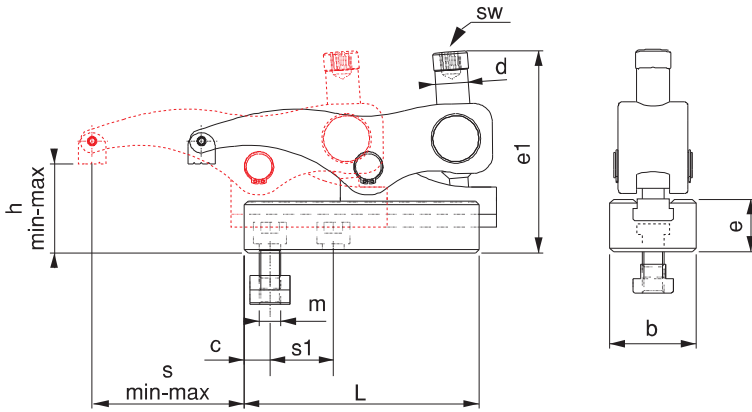

UYGULAMA;

- 1- Alt kızıağı iş parçasına uygun şekle getir sabitle
- 2- Üst gövdeyi kızıağa sür, istenilen pozisyona getir
- 3- Pabuç imbus civatasıyla iş parçasını sabitle
- 4- Parça işlenmek için hazır

APPLICATION;

- 1- Slide cradle is brought to suitable form with the work piece and then it is fixed
- 2- Upper body is driven to the slide and it is brought to desired position
- 3- Work piece is fixed with the imbus bolt of the clamp
- 4- Then the work piece becomes ready to be machined.

Kullanım Alanı

Enjeksiyon makineleri presler, freze tezgahları, matkap tezgahları ve çeşitli sanayi makineleri

Area of Use
Injection Machines, Presses, Milling Machines, Drilling Machines and various Industrial Machines

