

Referans Nr.	Toplam Tork Total Stroke (mm)	Sıkma Torku Lock Stroke (mm)	Ekstra Tork Extra Stroke (mm)	Max. Basınç Max. operating pressure kg/cm	Min. Basınç Min. operating pressure kg/cm	Sıkma Kuvveti Clamping Force (at 70 kg/cm ²)	Çalışma Isısı Operating Temperature	 (kg)
1052-VT25S	23.5	20.5	3	70	20	280kg	0 - 70°C	0.60
1052-VT32S	26	23	3	70	20	448kg	0 - 70°C	0.92
1052-VT40S	29.5	26.5	3	70	20	700kg	0 - 70°C	1.86
1052-VT50S	35	32	3	70	20	1092kg	0 - 70°C	2.34
1052-VT63S*	41	38	3	70	20	1736kg	0 - 70°C	3.90



Ürün Nr. 1052 Hidrolik Üstten Bağlama

- 1052-VT63S kodlu ürün manifoldlu ve yağ giriş, yağ dönüşlüdür.

Product Nr. 1052 Hydraulic Above Clamp

- 1052-VT63S coded products manifold and oil flow, oil is reflexive.

Borulu ve Manifoldlu With Pipe and the Manifold

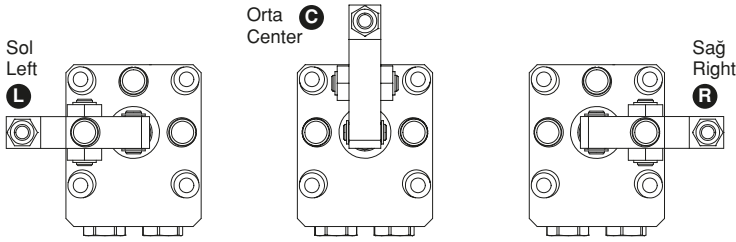

Referans Nr.	A	B	C	E	F	G
1052-VT25S	40	M5x0.8	48	30	11	3
1052-VT32S	47	M6	55	33.5	12	3
1052-VT40S	55	M6	65	39.5	15	5
1052-VT50S	63	M8	75	45	16	5
1052-VT63S	75	M10	90	52.5	18.5	5

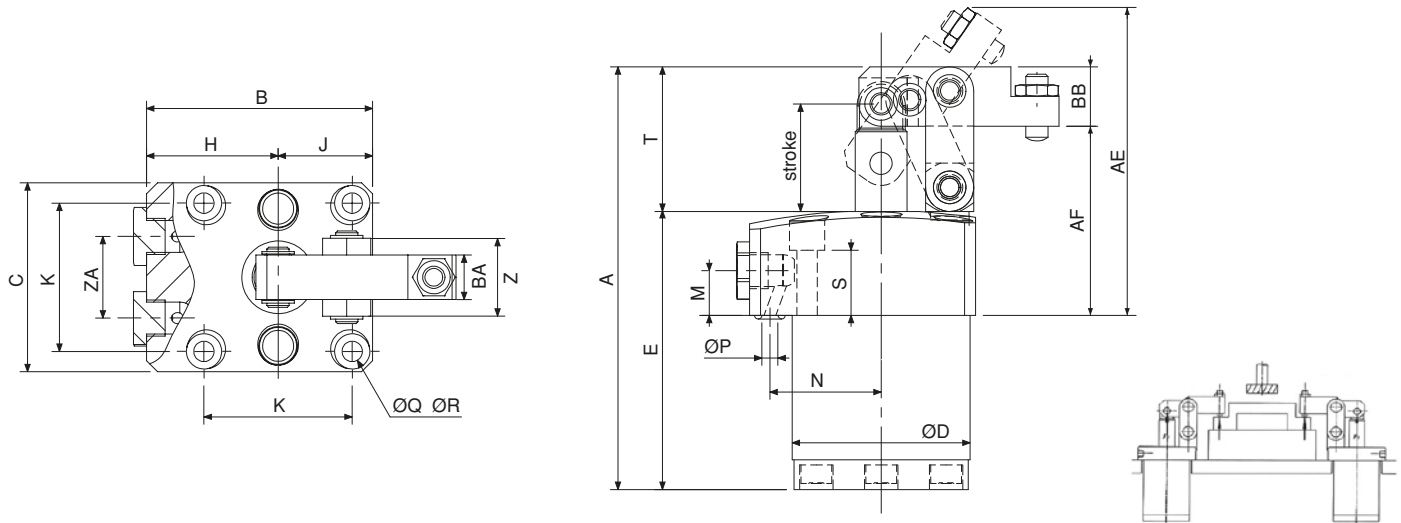
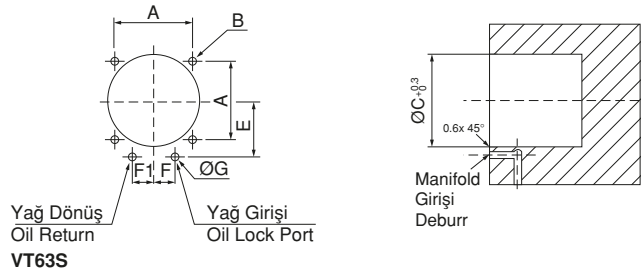

Referans Nr.	A	B	C	D	E	H	J	K	M	N	S	T	Z	part	ZA	Bağlama Pabucu Clamping Arm				ØQ	ØR
																AE	AF	BA	BB		
1052-VT25S	114	61	51	48	75	35.5	25.5	40	12	30	17.5	35	21	G1/8	22	92.4	51	12	16	9.5	5.5
1052-VT32S	132.5	69	60	55	87	39	30	47	12	33.5	15	37.5	28	G1/8	24	101.9	53.5	16	20	11	6.8
1052-VT40S	147	81	70	65	93	46	35	55	13	39.5	15.5	45	37	G1/4	30	111.4	59	19	25	11	6.8
1052-VT50S	175	94.5	85	75	108	52	42.5	63	16	45	19.5	55	40	G1/4	32	130.8	72	22	32	14	9
1052-VT63S	207	109.5	100	90	128	59.5	50	75	16	52.5	19	64.5	49	G3/8	37	146.5	81	25	38	17.5	11