

Referans Nr.	A (mm)	B (mm)	C (mm)	D (mm)	E (mm)	F (mm)	G (mm)	H (mm)	J (mm)	K (mm)	M (mm)	N (mm)	P (mm)	Q (mm)	R (mm)	T (mm)	Z (mm)	A1 (mm)	L1 (mm)	N1 (mm)	(kg)
1051-VS035	129	61	51	48	80	52	28	35.5	25.5	40	12	30	3	9.5	5.5	16	22	65.5	42	M6	0.84
1051-VS042	146	69	60	55	87	59	28	39	30	47	12	33.5	3	11	6.5	18.5	24	77	50	M8	1.25
1051-VS050	153	81	70	65	93	63	30	46	35	55	13	39.5	5	11	6.5	20	30	91.5	56.5	M10	1.86
1051-VS060	179	92	80	75	108	71	37	52	40	63	16	45	5	14	8.5	23.5	32	105	65	M12	2.86
1051-VS074	192	107	95	90	114	74	40	59.5	47.5	75	16	52.5	5	17.5	10.5	25	37	127	75	M16	4.75

Referans Nr.	Silindir Alan cm <sup>2</sup> Cylinder Area cm <sup>2</sup>	Toplam Strok Total Stroke	Sıkma Strok Clamp Stroke	Dönme Strok Swivel Stroke	Silindir Hacmi cm <sup>3</sup> /Sıkma Cylinder Volume cm <sup>3</sup> /Clamp	Silindir Hacmi cm <sup>3</sup> /Boşta Cylinder Volume cm <sup>3</sup> /Release	Maximum Çalışma Basıncı 70 kg/cm <sup>2</sup> Clamping Force at 70 kg/cm <sup>2</sup>	Min./Max. Çalışma Basıncı kg /cm <sup>2</sup> Min./Max. Operating Pressure kg /cm <sup>2</sup>	Çalışma Sıcaklığı Operating Temperature	90° Dönme Açılı Toleransı 90° Swing Angle Tolerance	Sıkma Salıncak Pozisyon Tekrarı Clamp-Swing Position Repeat Tolerance
1051-VS035	5.8	22	8	14	12.8	21.2	405	5 - 70	0-70°	90±2°	0.5°
1051-VS042	8.9	25	10	15	22.4	34.6	625	5 - 70	0-70°	90±2°	0.5°
1051-VS050	12.6	26	10	16	32.7	51.0	880	5 - 70	0-70°	90±2°	0.5°
1051-VS060	18.4	29	12	17	53.3	82.0	1285	5 - 70	0-70°	90±2°	0.5°
1051-VS074	27.1	30	12	18	81.3	129.0	1896	5 - 70	0-70°	90±2°	0.5°

### Ürün Nr. 1051 Hidrolik Dönmeli Bağlama

### Product Nr. 1051 Hydraulic Rotary Linking

### Borulu ve Manifodlu With Pipe and the Manifold

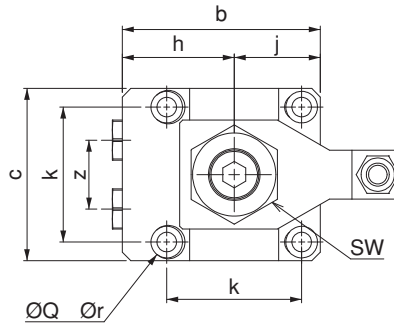
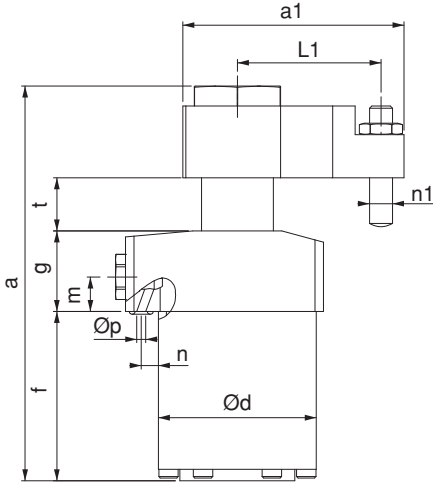

Referans Nr.	A	B	C	E	F	G
1051-VS035	40	M5	48	30	22	3
1051-VS042	47	M6	55	33.5	24	3
1051-VS050	55	M6	65	39.5	30	5
1051-VS060	63	M8	75	45	32	5
1051-VS074	75	M10	90	52.5	37	5

