

Hydraulik-Komponenten

Hydraulic Components



Anwendung

Der hydraulische Schwenkspanner ist die beste Auswahl, wenn Werkstücke frei zugänglich eingelegt werden müssen und höhere Spannkraften in Spanneinrichtungen benötigt sind.

Funktion

Der Zylinder hat Zieh-Eigenschaft. Der Gesamthub entspricht dem Dreh- und Ziehhub.

Type

Der Zylinder übt Druck nach unten aus. Er bewegt sich im Uhrzeigersinn und umgekehrt. Standardwinkel ist 90°, optional 0°-45° und 60°.

Material

Der Grundkörper ist aus Aluminiumlegierung.



Application

When machining a workpiece by means of a machine tool, a hydraulic swing clamping cylinder will be your best choice if the placing and taking of the workpiece are not allowed to be interfered by the clammer and need a larger clamping force.

Function

This cylinder belongs to a pull cylinder of which the total stroke is equal to the sum of a swing stroke and a clamping stroke, and is usually used within the clamping stroke.

Type

This swing cylinder belongs to a double-acting type which is operated mainly in a downward pressing manner, including clockwise swing and counterclockwise swing; standard angle is 90°, and optional angles include 0°, 45°, 60°; clamping means includes single arm or double arms; the mounting manner includes threaded type and lower flange type for manifold mounting with O-ring seal.

Material

This material of the main body is aluminum alloy.



Bestellbeispiel / Ordering example

Referenz-Nr. Order No.

NHS

Basis-Nr.
Base No.

T

Type

Flansch
Flange

T: verzahnt
T: Threaded

D

Arm Type

D: Doppelarm
D: Double Arm

Leer : Einzelbewegung
Blank: Single Arm

L –

Drehrichtung
Swivel Direction

L: links
L: Left

R: rechts
R: Right

40

Kolben / Piston Ø

25
32
40
50
63

x 90° –

Winkel / Angle

0°
45°
60°
90°
180°

Schematische Übersicht theoretischer Spannkraften unter unterschiedlichem Hydraulik-Druck

Schematic view showing a theoretical clamping force under different hydraulic pressure:

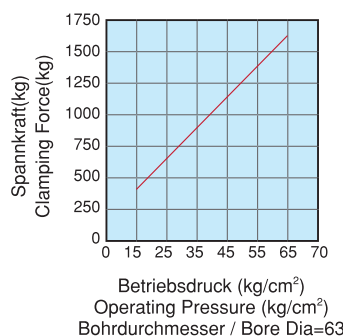
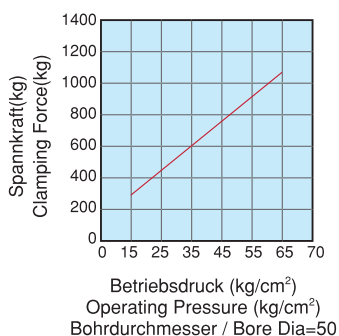
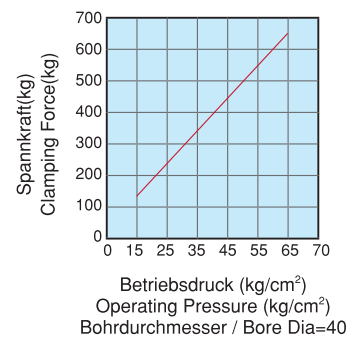
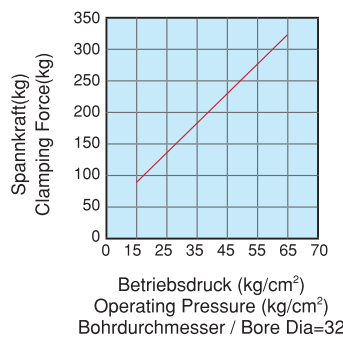
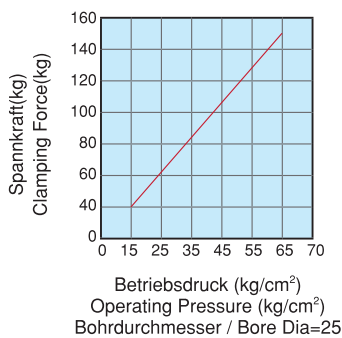

Referenz-Nr. Order No.	Spann-Type Mounting Type	Spannarm Clamping Arm	Max. Druck Max. Pressure	Normaldruck Normal Pres.	Bewegungs-Type Acting Type	Drehwinkel Swivel Angle	Drehhub Swivel Stroke (mm)	Spannhub Clamp. Str. (mm)	Bohrdurchmesser Diameter Ø (mm)	Kolbenstange Piston Rod Ø	Spannkraft Force (25kg/cm ²)	A (mm) Lösen Unclamp	B (mm)	C (mm)	D (mm)	G (mm)	H (mm)	L1 Spannen / Clamp L2 Lösen / Unclamp	N (mm)	P (mm)	Q (mm)	R (mm)	S (mm)	O-Ring Manifold O-Ring	M (mm)	F (mm)	Gewicht Weight (kg)				
1043-NHS025	Bottom Flange	1-Arm / Single Arm	70 kg/cm ²	20-45 kg/cm ²	doppelseitige Bewegung / Double Acting	90° (0° 45°, 60°, 180°) ± 2°	12	14	25	18	59	100	70	23	□	25.4	50	10	1/8 PF	M10 x1.5	40	50	∅ 6.5	∅ 45	S4	18	15	0.8			
1043-NHS032							14	15	32	20	125	111	76	25	□	25.4	55	10	□	55	10	1/8 PF	M10 x1.5	44	55	∅ 6.5	∅ 50	S4	24	17	1.0
1043-NHS040							14	15	40	20	200	113.6	80	27	□	25.4	55	10	□	55	10	1/8 PF	M10 x1.5	48	62	∅ 8.5	∅ 54	S4	26	20	1.1
1043-NHS050							14	15	50	20	400	114.5	80	27	□	25.4	55	10	□	55	10	1/8 PF	M10 x1.5	57	74	∅ 8.5	∅ 65	S4	30	25	1.4
1043-NHS063							14	15	63	25	600	118	85	32	□	32	75	11	□	75	11	1/8 PF	M12 x1.75	70	88	∅ 10.5	∅ 80	S4	40	30	2.3

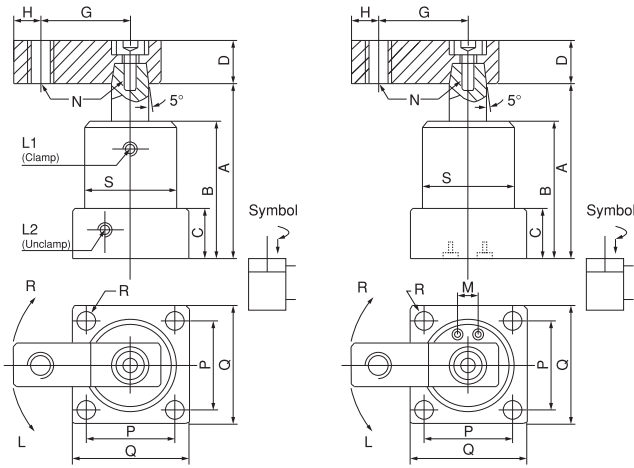

1043

NHS – Flanschversion, 1-Arm
Mit Rohr oder Verteiler

NHS – Flange Version, Single Arm
With Pipe or Manifold

- Bei Bestellung bitte Bewegungs-Type und Drehwinkel angeben.
- Before buying please, movement indicate the type and rotation angle.



Hydraulischer Schwenkspanner

Hydraulic Swing Clamp

Referenz-Nr. Order No.	Spann-Type Mounting Type	Spannarm Clamping Arm	Max. Druck Max. Pressure	Normaldruck Normal Pres.	Bewegungs-Type Acting Type	Drehwinkel Swivel Angle	Drehhub Swivel Stroke (mm)	Spannhub Clamp. Str. (mm)	Bohrdurchmesser Diameter Ø (mm)	Kolbenstange Piston Rod Ø	Spannkraft/Clamp Force (25kg/cm ²)	A (mm) Lösen Unclamp	B (mm)	C (mm)	D (mm)	G (mm)	H (mm)	L1 Spannen / Clamp L2 Lösen / Unclamp	N (mm)	P (mm)	Q (mm)	R (mm)	S (mm)	O-Ring Manifold O-Ring	M (mm)	F (mm)	Gewicht Weight (kg)
1045-NHSD025	Bottom Flange	2-Arm / Single Arm	70 kg/cm ²	20-45 kg/cm ²	doppelseitige Bewegung / Double Acting	90° (0° 45°, 60°, 180°) ± 2°	12	14	25	18	59	100	70	23	□	19	100	1/8 PF	∅ 8	40	50	∅ 6.5	∅ 45	S4	18	15	0.9
1045-NHSD032							14	15	32	20	125	111	76	25	□	22	120	1/8 PF	∅ 8	44	55	∅ 6.5	∅ 50	S4	24	17	1.1
1045-NHSD040							14	15	40	20	200	113.6	80	27	□	22	120	1/8 PF	∅ 8	48	62	∅ 8.5	∅ 54	S4	26	20	1.2
1045-NHSD050							14	15	50	20	400	114.5	80	27	□	22	120	1/8 PF	∅ 8	57	74	∅ 8.5	∅ 65	S4	30	25	1.5
1045-NHSD063							14	15	63	25	600	118	85	32	□	25.4	140	1/8 PF	∅ 10	70	88	∅ 10.5	∅ 80	S4	40	30	2.5

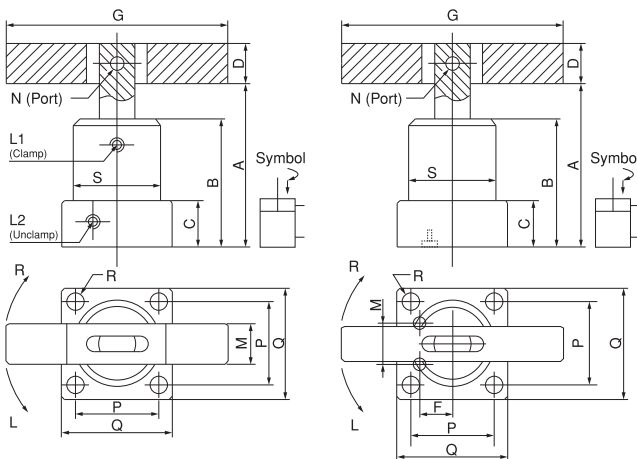

1045

NHSD – Flanschversion, Doppelarm
Mit Rohr oder Verteiler

NHSD – Flange Version, Double Arm
With Pipe or Manifold

- Bei Bestellung bitte Bewegungs-Type und Drehwinkel angeben.
- Before buying please, movement indicate the type and rotation angle.



Referenz-Nr. Order No.	Spann-Type Mounting Type	Spannarm Clamping Arm	Max. Druck Max. Pressure	Normaldruck Normal Pres.	Bewegungs-Type Acting Type	Drehwinkel Swivel Angle	Drehhub Swivel Stroke (mm)	Spannhub Clamp Str. (mm)	Bohrdurchmesser/ Bore Diameter Ø (mm)	Kolbenstange Piston Rod Ø	Spannkraft/Clamp Force (25kg/cm ²)	A (mm) Lösen Unclamp	B (mm)	C (mm)	D (mm)	G (mm)	H (mm)	I (mm)	L1 Spannen / Clamp L2 Lösen / Unclamp	N (mm)	S (mm)	T (mm) Konturmutter 2 St. T (mm) 2 pcs/set	Y (mm)	Gewicht Weight (kg)
1047-NHTS025	verzahnter Körper / Threaded Body	1-Arm / Single Arm	70 kg/cm ²	20-45 kg/cm ²	doppelseitige Bewegung / Double Acting	90° (0° 45°, 60°, 180°) ± 2°	12	14	25	18	59	100	70	35	□ 25.4	50	10	9	1/8 PF	M10 x1.5	M45 x1.5	∅ 65	10	0.8
1047-NHTS032							14	15	32	20	125	111	76	45	□ 25.4	55	10	9	1/8 PF	M10 x1.5	M50 x1.5	∅ 70	11	1.1
1047-NHTS040							14	15	40	20	200	113.6	80	45	□ 25.4	55	10	9	1/8 PF	M10 x1.5	M55 x1.5	∅ 75	11	1.25
1047-NHTS050							14	14	50	20	400	120	87	50	□ 25.4	55	10	9	1/8 PF	M10 x1.5	M65 x1.5	∅ 85	12	1.7

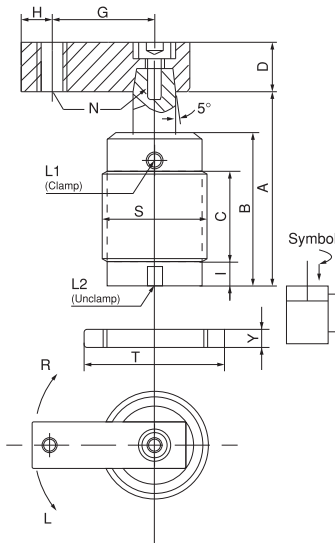

1047

NHTS – Verzahnte Version, 1-Arm
Mit Rohr

NHTS – Threaded Version, Single Arm
With Pipe

- Bei Bestellung bitte Bewegungs-Type und Drehwinkel angeben.
- Before buying please, movement indicate the type and rotation angle.



Hydraulischer Schwenkspanner

Hydraulic Swing Clamp

Referenz-Nr. Order No.	Spann-Type Mounting Type	Spannarm Clamping Arm	Max. Druck Max. Pressure	Normaldruck Normal Pres.	Bewegungs-Type Acting Type	Drehwinkel Swivel Angle	Drehhub Swivel Stroke (mm)	Spannhub Clamp Str. (mm)	Bohrdurchmesser/ Bore Diameter Ø (mm)	Kolbenstange Piston Rod Ø	Spannkraft/Clamp Force (25kg/cm ²)	A (mm) Lösen Unclamp	B (mm)	C (mm)	D (mm)	G (mm)	I (mm)	L1 Spannen / Clamp L2 Lösen / Unclamp	N (mm)	S (mm)	T (mm) Konturmutter 2 St. T (mm) 2 pcs/set	Y (mm)	Gewicht Weight (kg)
1050-NHTSD-25	verzahnter Körper / Threaded Body	2-Arm / Double Arm	70 kg/cm ²	20-45 kg/cm ²	doppelseitige Bewegung / Double Acting	90° (0° 45°, 60°, 180°) ± 2°	12	14	25	18	59	100	70	35	□ 19	100	9	1/8 PT	∅ 8	M45 x1.5	∅ 65	10	0.9
1050-NHTSD-32							14	15	32	20	125	111	76	45	□ 22	120	10	1/8 PT	∅ 8	M50 x1.5	∅ 70	11	1.2
1050-NHTSD-40							14	15	40	20	200	113.6	80	45	□ 22	120	10	1/8 PT	∅ 8	M55 x1.5	∅ 75	11	1.4
1050-NHTSD-50							14	14	50	20	400	120	87	50	□ 22	120	10	1/8 PT	∅ 8	M65 x1.5	∅ 85	12	1.85

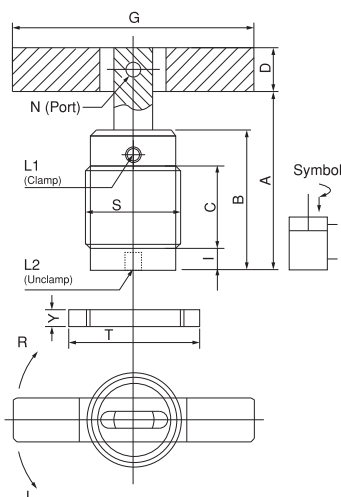

1050

NHTSD – Verzahnte Version, Doppelarm
Mit Rohr

NHTSD – Threaded Version, Double Arm
With Pipe

- Bei Bestellung bitte Bewegungs-Type und Drehwinkel angeben.
- Before buying please, movement indicate the type and rotation angle.



Referenz-Nr. Order No.	A (mm)	B (mm)	C (mm)	D (mm)	E (mm)	F (mm)	G (mm)	H (mm)	J (mm)	K (mm)	M (mm)	N (mm)	P (mm)	Q (mm)	R (mm)	T (mm)	Z (mm)	A1 (mm)	L1 (mm)	N1 (mm)	
1051-VS035	129	61	51	48	80	52	28	35.5	25.5	40	12	30	3	9.5	5.5	16	22	65.5	42	M6	0.84
1051-VS042	146	69	60	55	87	59	28	39	30	47	12	33.5	3	11	6.5	18.5	24	77	50	M8	1.25
1051-VS050	153	81	70	65	93	63	30	46	35	55	13	39.5	5	11	6.5	20	30	91.5	56.5	M10	1.86
1051-VS060	179	92	80	75	108	71	37	52	40	63	16	45	5	14	8.5	23.5	32	105	65	M12	2.86
1051-VS074	192	107	95	90	114	74	40	59.5	47.5	75	16	52.5	5	17.5	10.5	25	37	127	75	M16	4.75

Referenz-Nr. Order No.	Zylinderfläche cm ² Cylinder Area cm ²	Gesamthub Total Stroke	Spannhub Clamp Stroke	Drehhub Swivel Stroke	Ölvolumen cm ³ / Spannen Cylinder Volume cm ³ /Clamp	Ölvolumen cm ³ / Entspannen Cylinder Volume cm ³ /Release	Spannkraft 70 kg/cm ² Clamping Force at 70 kg/cm ²	Min./Max. Betriebsdruck kg/cm ² Min./Max. Operating Pressure kg/cm ²	Arbeitstemperatur Operating Temperature	90° Drehwinkel Toleranz 90° Swing Angle Tolerance	Wiederholgenauigkeit Clamp-Swing Position Repeat Tolerance
1051-VS035	5.8	22	8	14	12.8	21.2	405	5 - 70	0-70°	90±2°	0.5°
1051-VS042	8.9	25	10	15	22.4	34.6	625	5 - 70	0-70°	90±2°	0.5°
1051-VS050	12.6	26	10	16	32.7	51.0	880	5 - 70	0-70°	90±2°	0.5°
1051-VS060	18.4	29	12	17	53.3	82.0	1285	5 - 70	0-70°	90±2°	0.5°
1051-VS074	27.1	30	12	18	81.3	129.0	1896	5 - 70	0-70°	90±2°	0.5°

1051

Mit Rohr und Verteiler With Pipe and Manifold

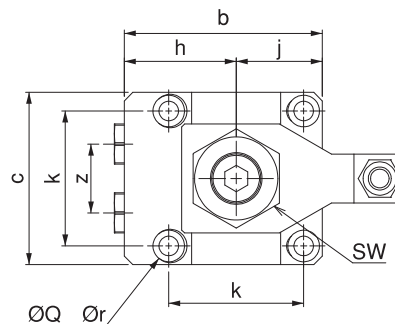
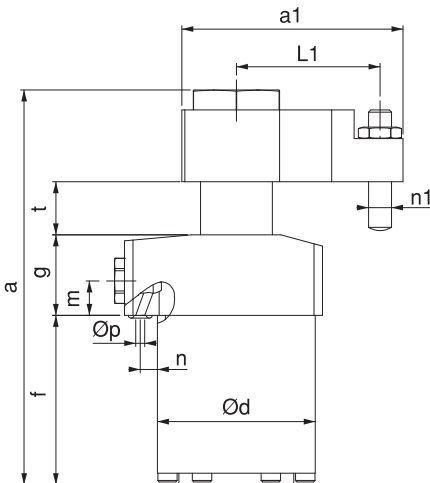

Referenz-Nr. Order No.	A	B	C	E	F	G
1051-VS035	40	M5	48	30	22	3
1051-VS042	47	M6	55	33.5	24	3
1051-VS050	55	M6	65	39.5	30	5
1051-VS060	63	M8	75	45	32	5
1051-VS074	75	M10	90	52.5	37	5

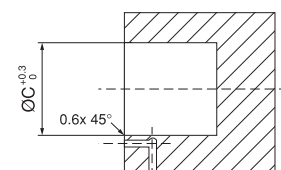
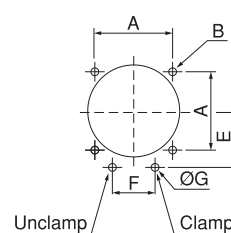

Referenz-Nr. Order No.	Gesamthub Total Stroke (mm)	Spannhub Lock Stroke (mm)	Extrahub Extra Stroke (mm)	Max. Druck Max. operating pressure kg/cm	Min. Druck Min. operating pressure kg/cm	Spannkraft Clamping Force (at 70 kg/cm ²)	Arbeitstemperatur Operating Temperature	 (kg)
1052-VT25S	23.5	20.5	3	70	20	280kg	0 - 70°C	0.60
1052-VT32S	26	23	3	70	20	448kg	0 - 70°C	0.92
1052-VT40S	29.5	26.5	3	70	20	700kg	0 - 70°C	1.86
1052-VT50S	35	32	3	70	20	1092kg	0 - 70°C	2.34
1052-VT63S	41	38	3	70	20	1736kg	0 - 70°C	3.90



1052

• 1052-VT63S codierte Produkte sind mit Verteiler und Ölfluss, das Öl ist regenerierend.

1052

• 1052-VT63S coded products manifold and oil flow, oil is reflexive.

Mit Rohr und Verteiler
With Pipe and Manifold

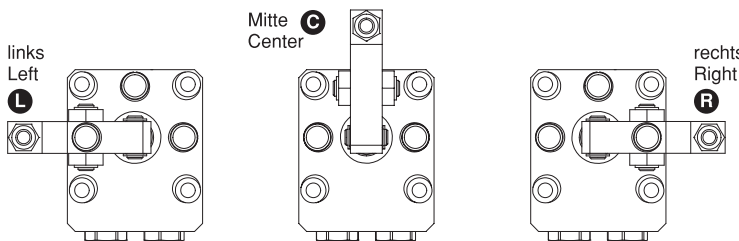

Referenz-Nr. Order No.	A	B	C	E	F	G
1052-VT25S	40	M5x0.8	48	30	11	3
1052-VT32S	47	M6	55	33.5	12	3
1052-VT40S	55	M6	65	39.5	15	5
1052-VT50S	63	M8	75	45	16	5
1052-VT63S	75	M10	90	52.5	18.5	5

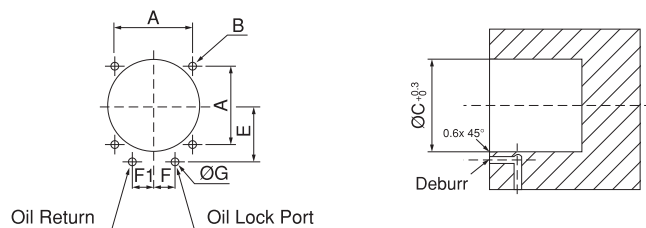

VT63S

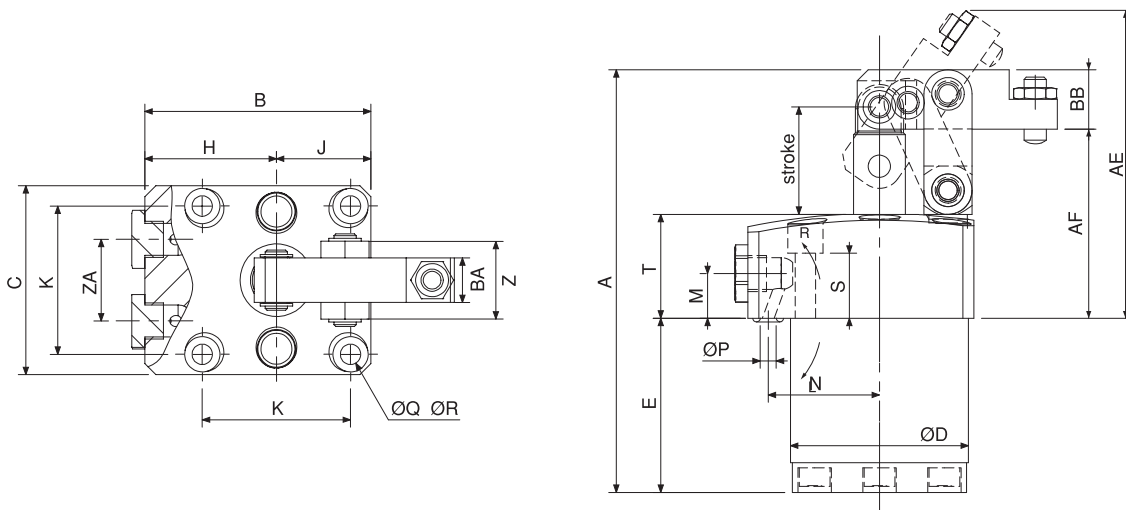

Referenz-Nr. Order No.	A	B	C	D	E	H	J	K	M	N	S	T	Z	part	ZA	Spanneisen Clamping Arm				ØQ	ØR
																AE	AF	BA	BB		
1052-VT25S	114	61	51	48	75	35.5	25.5	40	12	30	17.5	35	21	G1/8	22	92.4	51	12	16	9.5	5.5
1052-VT32S	132.5	69	60	55	87	39	30	47	12	33.5	15	37.5	28	G1/8	24	101.9	53.5	16	20	11	6.8
1052-VT40S	147	81	70	65	93	46	35	55	13	39.5	15.5	45	37	G1/4	30	111.4	59	19	25	11	6.8
1052-VT50S	175	94.5	85	75	108	52	42.5	63	16	45	19.5	55	40	G1/4	32	130.8	72	22	32	14	9
1052-VT63S	207	109.5	100	90	128	59.5	50	75	16	52.5	19	64.5	49	G3/8	37	146.5	81	25	38	17.5	11

Beschreibung

Dieser Einschraubzylinder wird in den ausgefahrenen Zustand gebracht und übt innerhalb eines Hubs eine Spannkraft auf ein Werkstück aus, um das Werkstück zu sichern. Die Montageweise dieses Einschraubzylinders ist in der folgenden Zeichnung dargestellt, die die empfohlenen Abmessungen der Geräte veranschaulicht, und diese Montage erfordert eine Teflondichtung, um Ölleckagen zu vermeiden.

Description

This threaded-body clamping cylinder is applied to a condition of knocking-out, and applies a clamping force on a workpiece within a stroke in order to secure the workpiece. The mounting manner for this threaded-body clamping cylinder is shown as the following drawing illustrating suggested dimensions of devices, and this mounting needs a Teflon packing in order to avoid oil leakage.



Bestellbeispiel / Ordering example

Nr. 1053 TC Basis Nr. Base No. 12 Kolben Ø 12 A Serie / Series

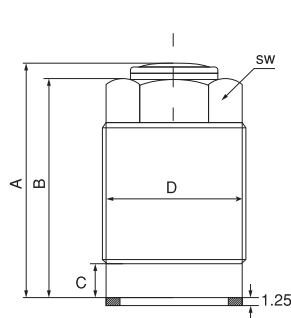

A Type

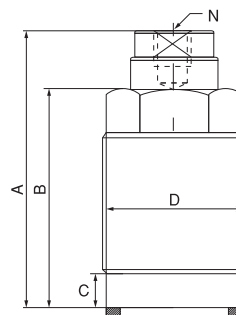

B Type

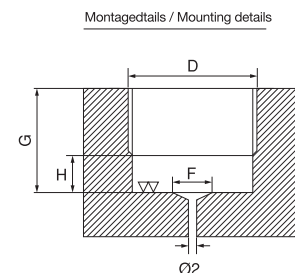

Spanndiagramm
Mounting Diagram

Referenz-Nr. Order No.	Arbeits-Öldruck Operating Oil Pressure	Bewegungs-Type Acting Type	Hub Stroke S(mm)	Kolbenstange Piston RodØ(mm)	Spannkraft/Clamp Force (200kg/cm ²)	A (mm)	B (mm)	C (mm)	D (mm)	F (mm)	G (mm)	H (mm)	N (mm)	sw	Gewicht Weight (kg)
1053-TC12A	20-350 kg/cm ²	einfachwirkend / Single Acting	10	12	200 (kg)	38	36	7	M22 x1.5	12	16	6	-	17	0.07
1053-TC16A			12	16	400 (kg)	46.5	44.5	8	M26 x1.5	16	20	7	-	22	0.14
1053-TC-20A			15	20	620 (kg)	56	54	8	M30 x1.5	20	24	7	-	24	0.22
1053-TC25A			16	25	980 (kg)	57	55	11	M38 x1.5	25	28	10	-	32	0.37
1053-TC12B			10	12	200 (kg)	45	36	7	M22 x1.5	12	16	6	M6x1	17	0.08
1053-TC16B			12	16	400 (kg)	52	44.5	8	M26 x1.5	16	20	7	M6x1	22	0.15
1053-TC20B			15	20	620 (kg)	64.5	54	8	M30 x1.5	20	24	7	M8x1.25	24	0.24
1053-TC25B			16	25	980 (kg)	67	55	11	M38 x1.5	25	28	10	M8x1.25	32	0.4

Referenz-Nr. Order No.	Hub Stroke (mm)		Zylinderkraft(kN) / Cylinder Force(kN)				Zylinderdurchmesser (mm) Cyl. inner dia. (mm)	Stängerdurchmesser (mm) Rod dia. (mm)	Wirkungsfläche (cm ²) Effec. area(cm ²)	Max. Ölflussfläche (l/min) Max. oil flow rate(l/min)	Zylinderkapazität (cm ³) Cylinder cap.(cm ³)		Rückkehr Federkraft (N) Return spring force (N)	Spannkraft Clamp Force (20kg/cm ²)
			Hydraulikdruck Hydraulic Press. 3.5 MPa	Hydraulikdruck Hydraulic Press. 7 MPa	Hydraulikdruck Hydraulic Press. 25 MPa	Hydraulikdruck Hydraulic Press. 35 MPa								
1055-CMD02	5	10	0.3	0.5	2.1	2.9	16	10	0.84	0.25	0.5	0.9	30~56	245
1055-CMD04	5	10	0.4	0.9	3.4	4.8	18	10	1.37	0.41	0.7	1.4	43~77	351
1055-CMD06	10	20	0.7	1.5	5.6	7.9	22	12	2.29	0.69	2.3	4.6	65~120	533
1055-CMD10	10	20	1.2	2.5	9.3	13	28	16	3.76	1.13	3.8	7.5	100~193	828
1055-CMD20	10	20	2	4.3	15.8	22.2	36	20	6.40	1.92	6.4	12.8	170~267	1400

1055

Bestellbeispiel
Ordering example

Nr. 1055

CMD

02

Serie / Series

16

Kolben Ø
Piston Ø

5

Hub / Stroke



Technische Daten / Technical Dimensions

	Hub (mm) Stroke (mm)		B	C	D		E	F	G		hex Weite (hex width across flats) sw	M1 (Körper mit Gewinde) (tip section thread)	M2 (Einschraub) (threaded body)	P	Q	R	S	T	U (Hydr. Verbindung) (hydraulic connection port)	V	W	X	Y	O-Ring Z	O-Ring ZZ	
	5	10			51	65			7.5	27																11
CMD02	5	10	10	20.3	51	65	10	15	7.5	27	36	M6×1 depth 11	M22 ×1.5	6.5	20.5	13	32.5	41.5	5.5	3	5	7	4	3	P6	AS568-017
CMD04	5	10	10	23.3	51	65	10	15	8	26.5	35.5	M6×1 depth 11	M25 ×1.5	6.5	23.5	14	32	41	5.5	3	5	7.5	4	3	P6	AS568-019
CMD06	10	20	12	28.3	69	96	16	26	9.5	35.5	52.5	M8×1.25 depth 18	M30 ×1.5	8	28.5	15	42.5	59.5	7	3	5	9.5	4	3	P6	AS568-022
CMD10	10	20	16	34.3	73	101	17	27	11.5	35.5	53.5	M10×1.5 depth 20	M36 ×1.5	9	34.5	17	43.5	61.5	8	4	5	12	4	3	P6	AS568-026
CMD20	10	20	20	46.3	80	109	19	29	13.5	35.5	54.5	M12×1.75 depth 22	M48 ×1.5	12	46.5	20	46.5	65.5	11	6	7	15	4	3	P8	AS568-031

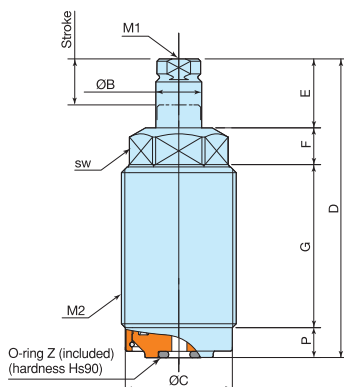

Montagedetails / Mounting details

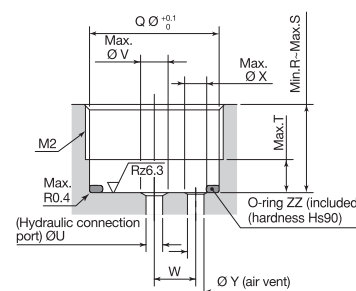

Referenz-Nr. Order No.	Stützkraft bei 70kg/cm ² Support Force	Hub Stroke	Max. Druck Max. Pressure	Normaldruck Normal Pressure	Anlegekraft Contact force	A	B	C	D	E	F	G	H	I	J	K	M	N	O	P	Q	R	S	CA	CB	CC	Gewicht Weight (kg)	
1056-WST26BL	200 kg	6	105 kg/cm ²	25 - 70 kg/cm ²	0.67	66	48	6.5	9	5	4	24	9	10	-	-	-	M6 x9D	-	24	26	10	M26 x1	M26 x1	20-30	2	0.20	
1056-WST30BL	300 kg	8			0.96	73	53	9.5	9	7	4	4	27	8	10	-	-	-	M6 x9D	-	28	30	10	M30 x1.5	M26 x1.5	20-50	9	0.25
1056-WST36BL	360 kg	8			2.12	69	50	9.5	8	7	4	4	32	11	10	-	-	-	M8 x11D	-	34.2	36	13	M36 x1.5	M26 x1.5	20-48	8	0.35
1056-WSU40BL	360 kg	8			1.82	67	31	25	14.5	7	4	-	-	11	12	22.5	31.5	5.5	M10 x8	26	34	45	13	Ø40	Ø40	-	-	0.60
1056-WSU48BL	720 kg	10			2.16	75	39	23	13.5	9	4	-	-	12	11	25.5	35.5	5.5	M10 x8	30	40	51	14	Ø48	Ø48	-	-	0.80
1056-WSU55BL	840 kg	12			1.33	85	45	23	11.5	11	6	-	-	15	14	30.5	39	6.8	M10 x10	33.5	47	60	18	Ø55	Ø55	-	-	1.40
1056-WSU65BL	1200 kg	14			1.05	101	56	27	14.5	12	6	-	-	17	14	35	46	6.8	M10 x10	40.5	55	70	20	Ø55	Ø55	-	-	2.20

1056

Niederdruck-Abstützelement

- der Betriebsdruck ist 25-70 kg/cm², mit Kopfflansch und einschraubbar
- Die Einlassöffnung ist kleiner, um die Geschwindigkeit des Kolbens zu verringern.

Wichtiger Hinweis zur Benutzung von Abstützelementen

- Reinheit des Hydrauliköls: Die inneren Teile des Abstützelements sind sehr präzise, deshalb ist die Reinheit des Öls ein sehr wichtiges Thema, das den Lebenszyklus beeinflussen kann. Eine schlechte Qualität des Öls wird zu geringerer Stützkraft führen. Normalerweise wird das Abstützelement wieder gut funktionieren, nachdem wir das Hydrauliköl gereinigt haben. In wenigen Bedingungen müssen wir das Abstützelement demontieren und die inneren Teile reinigen und die Öldichtung ersetzen.
- Reinigen Sie den Zylinderkörper: Die Metallverunreinigungen können während der Bearbeitung in das Innere gelangen, bitte reinigen Sie sie nach jeder Bearbeitung mit einer Luftpistole.
- Vermeiden Sie bitte folgendes oder der Abstützbolzen wird deformiert und der Kolben arbeitet nicht oder verliert die Stützkraft.

A: exzentrische Kraft auf den Kolben ausüben.

B: Last aufbringen, die die geschätzte Stützkraft übersteigt.

C: Den Kolben zu drehen, wenn in Stützposition



Work Support Low Pressure

- The operating range is 25-70 kg/cm², the mounting type includes thread body and upper flange, and we have piping mounting and manifold mounting in upper flange type.
- Inlet orifice is smaller, so it can reduce the speed of plunger when it is rising, it can reduce the impact onto workpiece, and reduce the tolerance which is caused by instant shock.

The important issue when you use work support

- The purity of hydraulic oil: the inner parts installed in work support are very precise, so the purity of hydraulic oil becomes a very important issue which can affect the life cycle of work support, bad quality of oil will cause to lose its supporting force. In usual, the work support will work well again after we clean the hydraulic oil, for few conditions, we need to disassemble the work support and clean the inner parts, even we need to replace oil seal.
- Clean the cylinder body: the metal impurity is possible going into the collet during the action, please make sure to clean by using an air gun after each machining.
- Please avoid the following condition, otherwise the collet will be deformed, and plunger will not work, or will lose supporting force.

A: Apply eccentric force onto plunger.

B: Apply an load which exceeds the estimated supporting force.

C: To turn the plunger when it is locked at supporting position

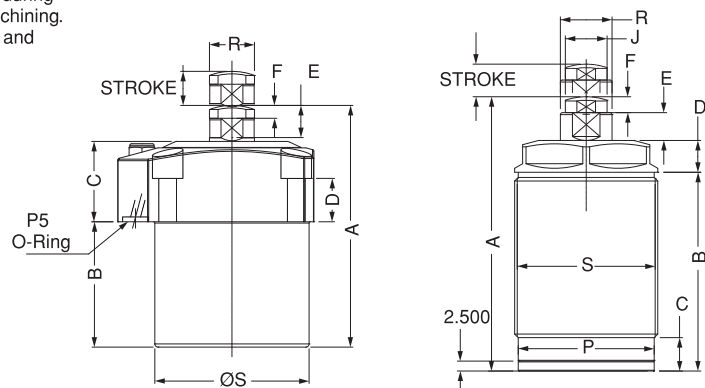
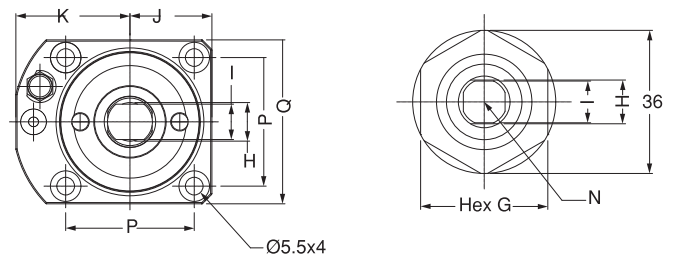

Montagedetails Mounting details

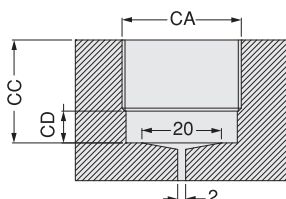

Referenz-Nr. Order No.	erweiterte Methode advanced method	Stützkraft bei 20 Mpa Supporting Force	Hub Stroke	Max. Druck Max. Pressure	Min. Druck Min. Pressure	Normaldruck Normal Pressure	Betriebstemperatur Operating Temperature	Anlegekraft / kg Contact force	A	B	C	C1	D	D1	D2	E	F	H1	H2	K	L	Q	U1	U2	O (O-ring)	Port	Gewicht Weight (kg)		
1056-WS16A	Spring	600 kgf	8	35 Mpa	5 Mpa	21 Mpa	0° ~ +70°	-	85.1	75.4	64.5	23.9	M35 x1.5	38.1	60.5	16	12.4	11.2	7.6	M10 x1.5	4.5	-	41.1	23.9	-	-	0.60		
1056-WS16B	Hidrolik Hydraulic	600 kgf	8					2.35	99.3	89.7	78.7	27.4	M35 x1.5	38.1	60.5	16	12.4	14.2	17.8	M10 x1.5	4.5	-	41.1	23.9	-	-	-	-	0.60
1056-WS30A	Spring	800 kgf	13					-	105	92	83	25	M60 x1.5	64	64	25	19	12.5	-	M10 x1.5	-	-	52	52	P7	G1/8	1.80		
1056-WS25B	Hidrolik Hydraulic	800 kgf	10.4					6.25	102.1	91.7	77.5	26.5	M50 x1.5	64	64	25	19	14	17.5	M16 x2	6	24.5	50	50	P7	G1/8	1.80		
1056-WS38A	Spring	1200 kgf	10.4					-	96.5	86.1	74.9	24.9	M68 x1.5	69.9	82.6	39	25.4	12.2	10.2	M20 x2.5	6.1	27.4	55.4	55.4	P10	G1/8	2.20		
1056-WS38B	Hidrolik Hydraulic	1200 kgf	10.4					8.86	102.1	91.7	78	26.4	M68 x1.5	69.9	82.6	38	25.4	13.7	13.2	M20 x2.5	6.1	27.4	55.4	55.4	P10	G1/8	2.20		

1056

Beschreibung

Das Abstützelement wird eingesetzt, um das Durchbiegen und Vibrieren der Werkstücke zu vermeiden.

Typen

Typ A: Ausfahren mit Federkraft; Eine Feder wird verwendet, um die Kontaktkraft zu steuern, wenn sich die Ausstoßstange bis in die höchste Ausstoßposition erstreckt und das Werkstück berührt.

Typ B: Ausfahren mit Öldruck; Wenn der Stützbolzen in tiefster Position ist, wird sie mittels Öldruck betätigt und beim Füllen mit Öl abgestossen und verwendet eine Feder, um die Kontaktkraft mit dem Werkstück zu steuern.

1056

Description

Hydraulic work support is used for avoiding deformation and decreasing vibration during machining.

Types

A type: knocking-out with a spring; the spring is used to control a contact force when the knocking out rod (piston rod) extends to a highest knocking-out position and contacts the workpiece.

B type: Knocking-out with oil pressure; when the knocking-out rod is at lowest position, it is operated by means of oil pressure and is knocked out when being filled with oil and uses a spring to control the contact force with the workpiece.

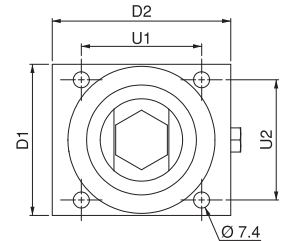
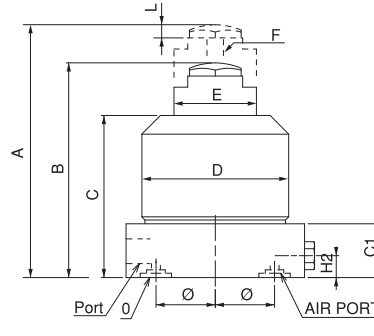
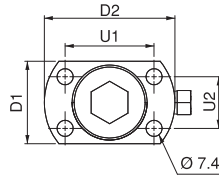
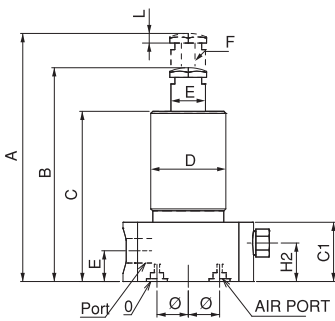

Referans Nr.	Betriebsdruck Operating Oil Pressure	Wirkungsart Acting Type	Hub Stroke	Kolbenstange Piston Rod Ø(mm)	Stützkraft 200kg/cm ² Supporting Force	Anlegekraft / kg Contact force	A	B	C	D	E	F	Gewicht Weight (kg)
1056-SP16A	100-350 kg/cm ²	Feder Spring	8	16	210 kg	-	79	54	8	M30 x1.5	11	8	0.30
1056-SP16B	100-350 kg/cm ²	Hydraulik Hydraulic	8	16	210 kg	2.35	72	54	8	M30 x1.5	11	8	0.30

1056

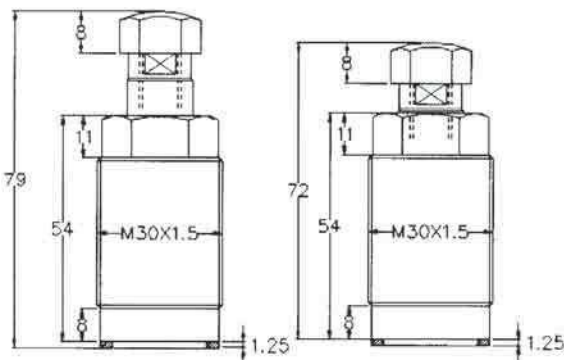

Montagedetails / Mounting details

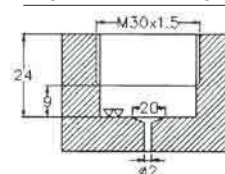

Hydraulisches Abstützelement

Hydraulic Work Support



Referenz-Nr. Order No.	Temperatur bis zu Temp. up to	Zylinder Piston Ø (mm)	Kolbenstange Piston Rod Ø (mm)	Zug bei 100 bar Force to pull at 100 bar (kgf)	Zug bei 500 bar Force to pull at 500 bar (kgf)	Federrückstellung Spring return force, min. (N)	Ölvolumen pro 10 mm Hub Oil volume per 10 mm stroke (cm ³)	a (mm)	b (mm)	c (mm)	f (mm)	g (mm)	h (mm)	k (mm)	m (mm)	n (mm)	o	p	r (mm)	s (mm)	t (mm)	SW (mm)	Hub Stroke ± 1 (mm)	l ± 1 (mm)	Gewicht Weight (kg)
1057-010016	100 °C	16	10	110	600	40	1.22	60	35	22	30	6.5	30	17.5	16.5	11	M6x12	G1/4	-	40	22	8	8	78	0.8
1057-015016	150 °C																								
1057-010025	100 °C	25	16	270	1430	140	2.90	65	45	27	50	8.5	33	22.5	18	11	M10x15	G1/4	-	50	30	13	8	91	1.2
1057-015025	150 °C																								
1057-010032	100 °C	32	20	460	2420	195	4.90	75	55	35	55	10.5	38	27.5	22	11	M12x15	G1/4	-	55	35	17	10	110	1.8
1057-015032	150 °C																								
1057-010040	100 °C	40	25	730	3790	270	7.65	85	63	35	63	10.5	40	31.5	24	11	M16x25	G1/4	4	63	40	-	10	114	2.6
1057-015040	150 °C																								
1057-010050	100 °C	50	32	1100	5730	440	11.60	100	75	35	76	13	44	37.5	27	13	M20x25	G1/4	4	76	45	-	12	125	3.8
1057-015050	150 °C																								
1057-010063	100 °C	63	40	1790	9230	430	18.60	125	95	44	95	17	50	47.5	26	17	M27x40	G1/2	4	95	65	-	12	146	6.7
1057-015063	150 °C																								
1057-010080	100 °C	80	50	2920	15180	760	30.63	160	120	46	120	21	60	60	34	21	M30x40	G1/2	5	120	80	-	12	193	12.8
1057-015080	150 °C																								
1057-100100	100 °C	100	63	4560	23500	1200	47.36	200	150	55	158	25	64	75	35	25	M42x60	G1/2	6	158	108	-	12	185	24
1057-150100	150 °C																								

1057

- Toleranzen für Längen- und Winkelmaße nach DIN 7168-m
- Tolerances for length and angle dimensions as per DIN 7168-m

wichtige Hinweise

Wenn die Möglichkeit besteht, dass aggressive Schneid- und Kühlmittel durch den Sintermetallluftfilter in das Zylinderinnere eindringen, muss ein Entlüftungsschlauch verbunden und in einer geschützten Position angeordnet sein.

Important notes

If there is a possibility that aggressive cutting lubricants and coolants penetrate through the sintered metal air filter into the cylinder's interior, a vent hose has to be connected and be placed in a protected position.

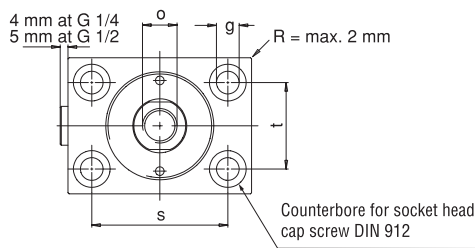

Die Zylinder müssen vorn getragen werden, um zu funktionieren. Druck über 250 bar

Cylinders must be supported at the front for operating pressures exceeding 250 bar

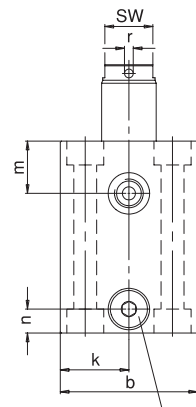
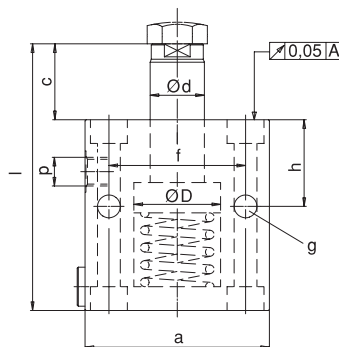
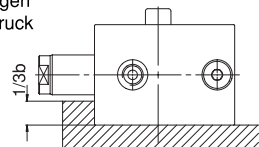

Entlüftung mit Stopfen mit Sintermetall-Luftfilter
Bleeding by plug with sintered metal air filter

Anwendung

Der pneumatische Schwenkspanner ist die beste Auswahl, wenn Werkstücke frei zugänglich eingelegt werden müssen und höhere Spannkraften in Spanneinrichtungen benötigt sind.

Funktion

Der Zylinder hat Zieh-Eigenschaft. Der Gesamthub entspricht dem Dreh- und Ziehhub.

Type

Der Zylinder übt Druck nach unten aus. Er bewegt sich im Uhrzeigersinn und umgekehrt. Standardwinkel ist 90°, optional 0°-45° und 60°.

Material

Der Grundkörper ist aus Aluminiumlegierung.



Application

When machining a workpiece by means of a machine tool, a pneumatic swing clamping cylinder will be your best choice if the placing and taking of the workpiece are not allowed to be interfered by the clammer and need a larger clamping force.

Function

This cylinder belongs to a pull cylinder of which the total stroke is equal to the sum of a swing stroke and a clamping stroke, and is usually used within the clamping stroke.

Type

This swing cylinder belongs to a double-acting type which is operated mainly in a downward pressing manner, including clockwise swing and counterclockwise swing; standard angle is 90°, and optional angles include 0°, 45°, 60°; clamping means includes single arm or double arms; the mounting manner includes threaded type and lower flange type for manifold mounting with O-ring seal.

Material

This material of the main body is aluminum alloy.



Bestellbeispiel / Ordering example

Referans Nr.	NAS Temel No. Base No.	T Type Flansch Flange T: verzahnt T: Threaded	D Arm Type D: Doppelarm D: Double Arm Leer : Einzelbewegung Blank: Single Arm	L – Drehrichtung Swivel Direction L: links L: Left R: rechts R: Right	40 Kolben / Piston Ø 25 32 40 50 63	x 90° – Winkel / Angle 0° 45° 60° 90° 180°
--------------	------------------------------	--	--	---	---	--

Schematische Übersicht theoretischer Spannkraften unter unterschiedlichem pneumatischen Druck Schematic view showing a theoretical clamping force under different pneumatic pressure:

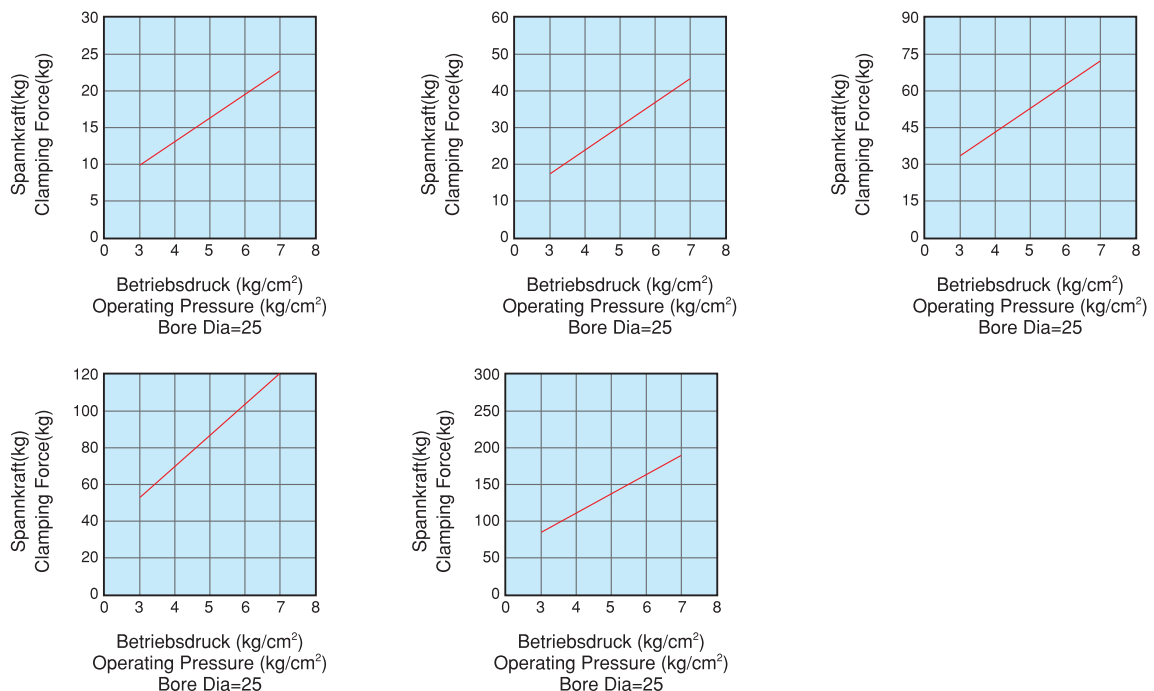

Referenz-Nr. Order No.	Spann-Type Mounting Type	Spannarm Clamping Arm	Max. Druck Max. Pressure	Normaldruck Normal Pres.	Bewegungs-Type Acting Type	Drehwinkel Swivel Angle	Drehhub Swivel Stroke (mm)	Spannhub Clamp. Str. (mm)	Bohrdurchmesser Diameter Ø (mm)	Kolbenstange Piston Rod Ø	Spannkraft Force (25kg/cm ²)	A (mm) Lösen Unclamp	B (mm)	C (mm)	D (mm)	G (mm)	H (mm)	L1 Spannen / Clamp L2 Lösen / Unclamp	I (mm)	P (mm)	Q (mm)	R (mm)	S (mm)	M (mm)	F (mm)	Gewicht Weight (kg)
1058-NAS025	Bottom Flange	1-Arm / Single Arm	7 kg/cm ²	4-6 kg/cm ²	doppelseitige Bewegung / Double Acting	90° (0° 45°, 60°, 180°) ± 2°	12	14	25	14	16	95.5	65.5	23	□ 16	30	8	M5	M6	30	40	∅ 4.5	∅ 35	18	12.5	0.40
1058-NAS032							12	14	32	16	30	102.5	71	23	□ 19	50	9	1/8 PF	M8	44	54	∅ 6.5	∅ 50	22	17	0.70
1058-NAS040							12	15	40	16	50	106	75	26	□ 19	50	9	1/8 PF	M8	48	58	∅ 6.5	∅ 55	26	19.5	0.85
1058-NAS050							14	15	50	20	85	113	80	26	□ 25.4	70	10	1/8 PF	M10	55	68	∅ 8.5	∅ 65	30	24	1.30
1058-NAS063							14	15	63	20	140	119	86	30	□ 25.4	70	10	1/8 PF	M10	64	80	∅ 8.5	∅ 70	40	20	1.80

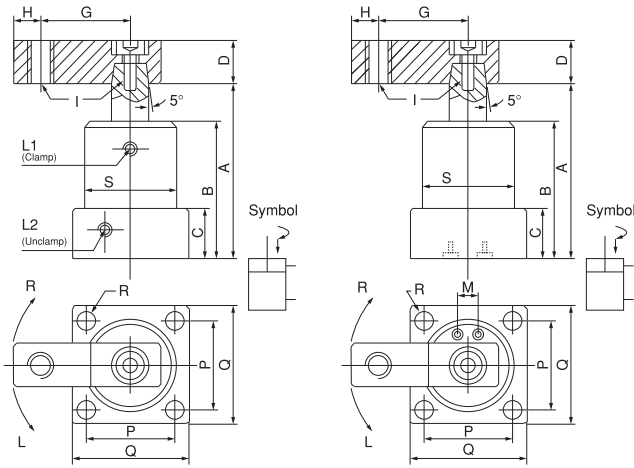

1058

NAS – Flanschversion, 1-Arm
Mit Rohr oder Verteiler

NAS – Flange Version, Single Arm
With Pipe or the Manifold

- Bei Bestellung bitte Bewegungs-Type und Drehwinkel angeben.
- Before buying please, movement indicate the type and rotation angle.



Pneumatischer Schwenkspanner

Pneumatic Swing Clamp

Referenz-Nr. Order No.	Spann-Type Mounting Type	Spannarm Clamping Arm	Max. Druck Max. Pressure	Normaldruck Normal Pres.	Bewegungs-Type Acting Type	Drehwinkel Swivel Angle	Drehhub Swivel Stroke (mm)	Spannhub Clamp. Str. (mm)	Bohrdurchmesser Diameter Ø (mm)	Kolbenstange Piston Rod Ø	Spannkraft Force (25kg/cm ²)	A (mm) Lösen Unclamp	B (mm)	C (mm)	D (mm)	G (mm)	H (mm)	L1 Spannen / Clamp L2 Lösen / Unclamp	N (mm)	P (mm)	Q (mm)	R (mm)	S (mm)	M (mm)	F (mm)	Gewicht Weight (kg)
1058-NASD032	Bottom Flange	2-Arm / Double Arm	7 kg/cm ²	4-6 kg/cm ²	doppelseitige Bewegung / Double Acting	90° (0° 45°, 60°, 180°) ± 2°	12	14	32	16	30	102.5	71	23	□ 19	100	1/8 PF	∅ 8	44	54	∅ 6.5	∅ 50	22	17	0.80	
1058-NASD040							12	15	40	16	50	106	75	26	□ 19	100	1/8 PF	∅ 8	48	58	∅ 6.5	∅ 55	26	19.5	0.95	
1058-NASD050							14	15	50	20	85	113	80	26	□ 22	120	1/8 PF	∅ 8	55	68	∅ 8.5	∅ 65	30	24	1.40	
1058-NASD063							14	15	63	25	140	119	86	30	□ 22	120	1/8 PF	∅ 8	64	80	∅ 8.5	∅ 75	40	29	1.90	

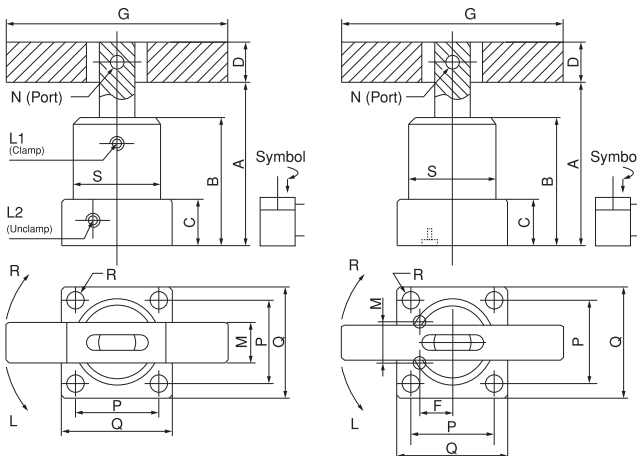

1058

NASD – Flanschversion, Doppelarm
Mit Rohr oder Verteiler

NASD – Flange Version, Double Arms
With Pipe or the Manifold

- Bei Bestellung bitte Bewegungs-Type und Drehwinkel angeben.
- Before buying please, movement indicate the type and rotation angle.



Referenz-Nr. Order No.	Spann-Type Mounting Type	Spannarm Clamping Arm	Max. Druck Max. Pressure	Normaldruck Normal Pres.	Bewegungs-Type Acting Type	Drehwinkel Swivel Angle	Drehhub Swivel Stroke (mm)	Spannhub Clamp. Str. (mm)	Bohrdurchmesser/ Bore Diameter Ø (mm)	Kolbenstange Piston Rod Ø	Spannkraft/Clamp Force (25kg/cm ²)	A (mm) Lösen Unclamp	B (mm)	C (mm)	D (mm)	G (mm)	H (mm)	I (mm)	L1 Spannen / Clamp L2 Lösen / Unclamp	N (mm)	S (mm)	T (mm) Keilmutter 2 St. T (mm) 2 pcs/set	Y (mm)	Gewicht Weight (kg)
1058-NATS025	verzählter Körper / Threaded Body	1-Arm / Single Arm	7 kg/cm ²	4-6 kg/cm ²	doppelseitige Bewegung / Double Acting	90° ± 2°	14	14	25	14	16	104	70	35	□ 16	50	6	10	M5	M6 x1	M40 x1.5	Ø 58	9	0.80
1058-NATS032							14	16	32	16	30	113	79	40	□ 19	60	9	13	1/8 PF	M8 x1.25	M50 x1.5	Ø 70	11	1.10
1058-NATS040							14	15	40	16	50	116	83	45	□ 19	70	9	13	1/8 PF	M8 x1.25	M55 x1.5	Ø 75	11	1.25
1058-NATS050							14	14	50	20	80	120	87	50	□ 25	80	10	13	1/8 PF	M12 x1.5	M65 x1.5	Ø 85	12	1.70
1058-NATS063							15	15	63	20	140	127	92	56	□ 25	90	10	13	1/8 PF	M12 x1.5	M80 x1.5	Ø 105	15	2.20

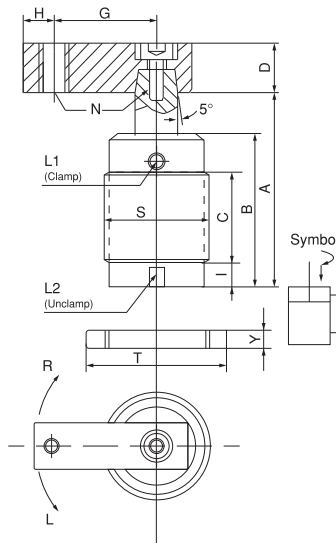

1058

NATS – Verzahnte Version, 1-Arm
Mit Rohr

NATS – Threaded Version, Single Arm
With Pipe

- Bei Bestellung bitte Bewegungs-Type und Drehwinkel angeben.
- Before buying please, movement indicate the type and rotation angle.



Pneumatischer Schwenkspanner

Pneumatic Swing Clamp

Referenz-Nr. Order No.	Spann-Type Mounting Type	Spannarm Clamping Arm	Max. Druck Max. Pressure	Normaldruck Normal Pres.	Bewegungs-Type Acting Type	Drehwinkel Swivel Angle	Drehhub Swivel Stroke (mm)	Spannhub Clamp. Str. (mm)	Bohrdurchmesser/ Bore Diameter Ø (mm)	Kolbenstange Piston Rod Ø	Spannkraft/Clamp Force (25kg/cm ²)	A (mm) Lösen Unclamp	B (mm)	C (mm)	D (mm)	G (mm)	I (mm)	L1 Spannen / Clamp L2 Lösen / Unclamp	N (mm)	S (mm)	T (mm) Keilmutter 2 St. T (mm) 2 pcs/set	Y (mm)	Gewicht Weight (kg)
1058-NATSD032	verzählter Körper / Threaded Body	2-Arm / Double Arm	7 kg/cm ²	4-6 kg/cm ²	doppelseitige Bewegung / Double Acting	90° (0° 45°, 60°, 180°) ± 2°	14	16	32	16	30	113	79	40	□ 19	100	13	1/8 PT	Ø 8	M50 x1.5	Ø 70	11	1.10
1058-NATSD040							14	15	40	16	50	116	83	45	□ 19	100	13	1/8 PT	Ø 8	M55 x1.5	Ø 75	11	1.30
1058-NATSD050							14	14	50	20	85	120	77	50	□ 22	120	13	1/8 PT	Ø 8	M65 x1.5	Ø 85	12	1.80

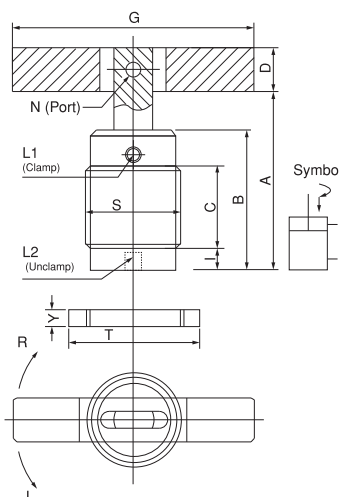

1058

NATSD – Verzahnte Version, Doppelarm
Mit Rohr

NATSD – Threaded Version, Double Arms
With Pipe

- Bei Bestellung bitte Bewegungs-Type und Drehwinkel angeben.
- Before buying please, movement indicate the type and rotation angle.



Referenz-Nr. Order No.	Betriebsdruck Operating Pressure	Arbeitstemperatur Operating Temperature	Spann-Typ Mounting Type	Hub Stroke (mm)	Bohrdurchmesser Diameter Ø (mm)	Kolbenstange Piston Rod Ø (mm)	Spannkraft Clamp. Force (7kg/cm ²)	A	B	C	D	E	F	G	H	I	J	K	L	M	O	N	P	Q	R	R1	S	L1 Spannen / Clamp	L2 Lösen / Unclamp	Gewicht Weight (kg)
1058-PLCU25	4-10 kgf/cm ²	-10° ~ +80°	Kopfflansch & Einschraubzylinder Upper Flange & Threaded Body	22	Ø 25	Ø 14	27	128.5	86.5	25	61.5	50	17	16	M40 x1.5	60	50	37	18	23	23	7	35	25	5.5	9	M6 x1	M5 x0.8	0.60	
1058-PLCU32				28	Ø 32	Ø 16	40	149.5	97.5	25	72.5	57	20	18	M50 x1.5	70	60	45	22	30	23	8	40	30	6.5	11	M8 x1.25	G 1/8	1.00	
1058-PLCU40				30	Ø 40	Ø 16	66	157.5	97.5	25	72.5	60	25	20	M55 x1.5	75	65	50	24	32	26	10	42.5	32.5	6.5	11	M8 x1.25	G 1/8	1.20	
1058-PLCU50				30	Ø 50	Ø 20	105	174	104	25	79	65	30	22	M65 x1.5	88	75	58	27.5	36	32	14	50.5	37.5	8.5	14	M12 x1.75	G 1/8	2.00	
1058-PLCU63				30	Ø 63	Ø 20	166	179	105	25	80	69	30	22	M80 x1.5	108	90	70	32	42	35	14	63	45	8.5	14	M12 x1.75	G 1/8	2.70	

1058



Mit Rohr / With Pipe

