

BAĞLAMA PABUÇLARI

CLAMPING COMPONENTS



Referans Nr.		L	Nr.1330		e1	e2	b1	Nr.1610	h	Nr.1490 D x F	 (g)
			a1	b2							
1170-1010080	10	80	15	30	15	30	11	M10x10x80	10-35	M10x42	370
1170-1212100	12	100	20	40	21	40	14.5	M12x12x100	12-40	M12x50	740
1170-1212125	12	125	20	40	21	50	14.5	M12x12x160	12-85	M12x95	940
1170-1214100	14	100	20	40	21	40	14.5	M12x14x100	12-40	M12x50	705
1170-1214125	14	125	20	40	21	50	14.5	M12x14x160	12-85	M12x95	965
1170-1616125	16	125	25	50	26	45	18.5	M16x16x125	15-50	M16x62	1115
1170-1616160	16	160	25	50	26	65	18.5	M16x16x160	15-85	M16x97	1870
1170-1618125	18	125	25	50	26	45	18.5	M16x18x125	15-50	M16x62	1540
1170-1618160	18	160	25	50	26	65	18.5	M16x18x160	15-85	M16x97	1900
1170-2020160	20	160	30	60	30	60	22.5	M20x20x160	15-45	M20x62	1675
1170-2020200	20	200	30	60	30	80	22.5	M20x20x200	15-80	M20x97	3295
1170-2022160	22	160	30	60	30	60	22.5	M20x22x160	15-45	M20x62	2730
1170-2022200	22	200	30	60	30	80	22.5	M20x22x200	15-80	M20x97	3340
1170-2424160	24	160	30	70	35	60	26.5	M24x24x160	16-60	M24x81	3465
1170-2424200	24	200	30	70	35	80	26.5	M24x24x200	16-95	M24x116	4660
1170-2428160	28	160	30	70	35	60	26.5	M24x28x160	16-60	M24x81	5560
1170-2428200	28	200	30	70	35	80	26.5	M24x28x200	16-95	M24x116	4755

Ürün Nr. 1170 Ayarlanabilir Destek Civatalı Kombine Bağlama Pabuç

• Ürün DIN 650 T-Kanala uyumludur.

Product Nr. 1170 Combined Coupling Clamp with Adjustable Support Bolt

• Product is suitable to DIN 650 T-Slot

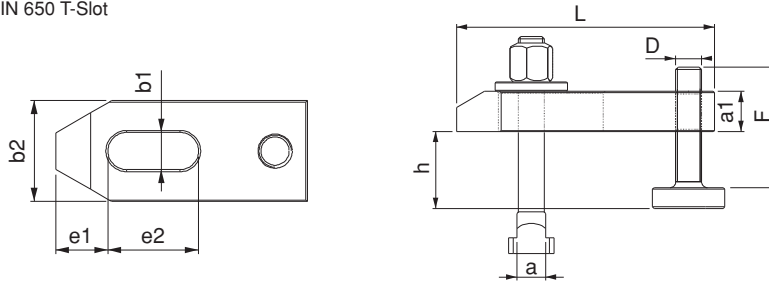

Referans Nr.		L	Nr.1450		e1	e2	b1	Nr.1610	h	Nr.1490 D x F	 (g)
			a1	b2							
1190-1010100	10	100	15	30	32	32	11	M10x10x80	26-50	M10x42	405
1190-1212125	12	125	20	40	40	40	14.5	M12x12x100	33-60	M12x50	870
1190-1214125	14	125	20	40	40	40	14.5	M12x14x100	37-60	M12x50	890
1190-1616160	16	160	25	50	49	50	18.5	M16x16x125	41-75	M16x62	1785
1190-1618160	18	160	25	50	49	50	18.5	M16x18x125	41-75	M16x62	1810
1190-2020200	20	200	30	60	55	70	22.5	M20x20x160	46-75	M20x62	3105
1190-2022200	22	200	30	60	55	70	22.5	M20x22x160	46-75	M20x62	3155
1190-2424200	24	200	35	70	72	60	26	M24x24x200	52-95	M24x81	4695
1190-2428200	28	200	35	70	72	60	26	M24x28x200	52-95	M24x81	4790

Ürün Nr. 1190 Ayarlanabilir Destek Civatalı Kombine Bağlama Z-Pabuç

• Kısıtlı yükseklik mesafelerinden kazanma amaçlı kullanılır.



• Ürün DIN 650 T-Kanala uyumludur.

Product Nr. 1190 Combined Coupling Z-Clamp with Adjustable Support Bolt

• This is used to gain from restricted height distances

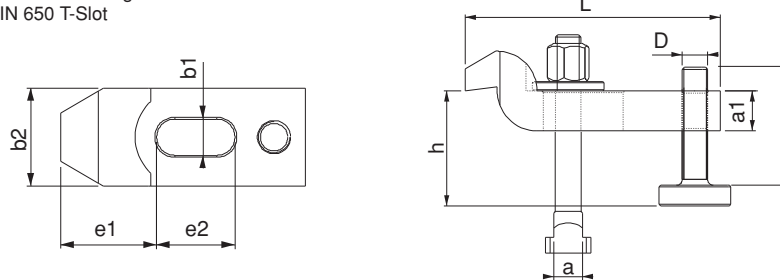
• Product is suitable to DIN 650 T-Slot



Referans Nr.		a1	a2	a3	b2xL	b3	e1	e2	h2	k	b1	m	h1	kgf	
1195-44115	10-12-14	27	12.5	12	44x115	30	25	30	21	11	13	M12	0-55	3000	506
1195-55150	12-14-16-18	36	18	17	55x150	41	35	36	23	12	17	M16	0-70	4000	1382
1195-63187	16-18-20-22	42	25	20	63x187	30	44	44	32.5	14	21	M20	0-80	6000	2241
1195-70235	20-22-24-28	51	36.5	24	70x235	30	60	47	34	17	25	M20	0-100	7500	3550

Ürün Nr. 1195 Çift Taraflı Bağlama Pabucu

- Malzeme: Dövme Çelik
- Sertleştirilmiş
- Siyah Kaplama

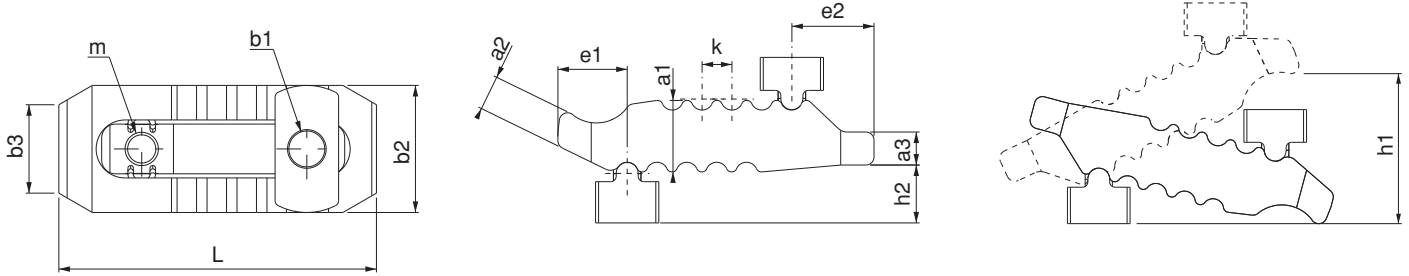

Product Nr. 1195 Coupling Clamps Double Sided

- Material: Forged Steel
- Hardened
- Black coating

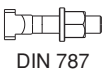

Kombine Çift Taraflı Bağlama Pabucu

Combined Coupling Clamps Double Sided

Referans Nr.	b1	b2xL	e1	h1	k	m			Sıkma Kuvveti Clamping Force kgf	
1195-1010100	13	44x115	25	0-55	11	M12	10	M10x10x100	2500	613
1195-1212125	13	44x115	25	0-55	11	M12	12	M12x12x125	3000	686
1195-1214125	13	44x115	25	0-55	11	M12	14	M12x14x125	3000	705
1195-1212160	17	55x150	35	0-70	12	M16	12	M12x12x160	3500	1591
1195-1214160	17	55x150	35	0-70	12	M16	14	M12x14x160	3500	1610
1195-1616160	17	55x150	35	0-70	12	M16	16	M16x16x160	4000	1798
1195-1618160	17	55x150	35	0-70	12	M16	18	M16x18x160	4000	1818
1195-1616200	21	63x187	44	0-80	14	M20	16	M16x16x200	5500	2715
1195-1618200	21	63x187	44	0-80	14	M20	18	M16x18x200	5500	3018
1195-2020200	21	63x187	44	0-80	14	M20	20	M20x20x200	6000	3018
1195-2022200	21	63x187	44	0-80	14	M20	22	M20x22x200	6000	3060
1195-2020250	25	70x235	60	0-100	17	M20	20	M20x20x250	7000	4368
1195-2022250	25	70x235	60	0-100	17	M20	22	M20x22x250	7000	4410
1195-2424250	25	70x235	60	0-100	17	M20	24	M24x24x250	7500	4895
1195-2428250	25	70x235	60	0-100	17	M20	28	M24x28x250	7500	4966

Ürün Nr. 1195 Kombine Çift Taraflı Bağlama Pabucu

- Ürün DIN 650 T-Kanala uyumludur.

Product Nr. 1195 Combined Coupling Clamps Double Sided

- Product is suitable to DIN 650 T-Slot

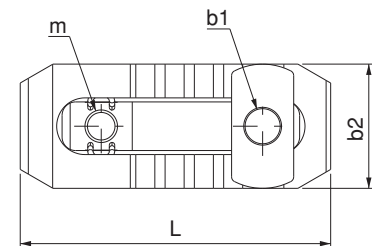
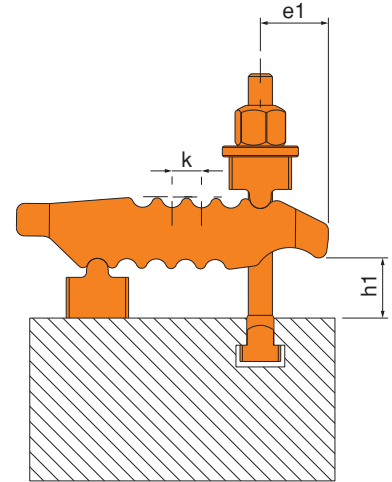

Referans Nr	B1	D x F	 DIN 787	h1
1195-10101005013	13	M12x50	M10x10x100	15-31
1195-12121605013	13	M12x50	M12x12x160	15-97
1195-12141605013	13	M12x50	M12x14x160	15-97
1195-12122006217	17	M16x62	M12x12x200	18-126
1195-12142006217	17	M16x62	M12x14x200	18-126
1195-16162006217	17	M16x62	M16x16x200	18-126
1195-16182006217	17	M16x62	M16x18x200	18-126
1195-12122009717	17	M16x97	M12x12x200	18-120
1195-12142009717	17	M16x97	M12x14x200	18-120
1195-16162509717	17	M16x97	M16x16x250	39-161
1195-16182509717	17	M16x97	M16x18x250	39-161
1195-16162506221	21	M20x62	M16x16x250	18-129
1195-16182506221	21	M20x62	M16x18x250	18-129
1195-20202506221	21	M20x62	M20x20x250	18-129
1195-20222506221	21	M20x62	M20x22x250	18-129
1195-16162509721	21	M20x97	M16x16x250	18-151
1195-16182509721	21	M20x97	M16x18x250	18-151
1195-20203159721	21	M20x97	M20x20x315	42-184
1195-20223159721	21	M20x97	M20x22x315	42-184
1195-20203156225	25	M20x62	M20x20x315	21-147
1195-20223156225	25	M20x62	M20x22x315	21-147
1195-24243156225	25	M20x62	M24x24x315	21-147
1195-24283156225	25	M20x62	M24x28x315	21-147
1195-20203159725	25	M20x97	M20x20x315	21-182
1195-20223159725	25	M20x97	M20x22x315	21-182
1195-24243159725	25	M20x97	M24x24x315	21-182
1195-24283159725	25	M20x97	M24x28x315	21-182

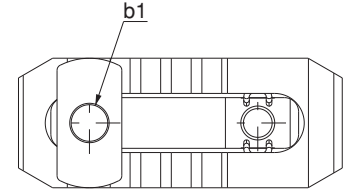
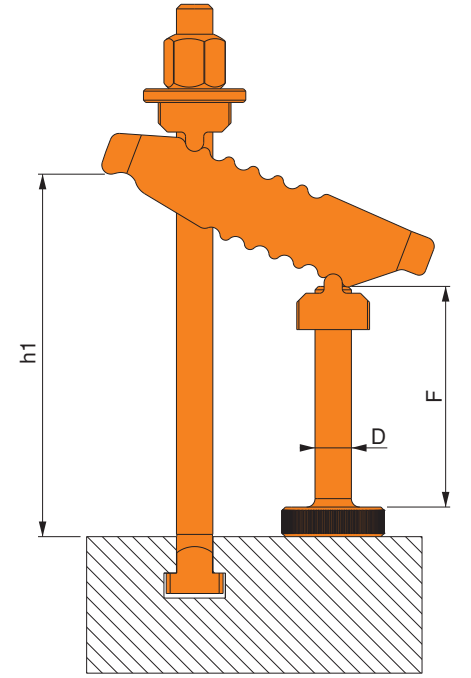



Ürün Nr. 1195 Kombine Çift Taraflı Bağlama Pabucu

- Ürün DIN 650 T-Kanala uyumludur.

Product Nr. 1195 Combined Coupling Clamps Double Sided

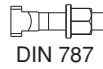
- Product is suitable to DIN 650 T-Slot

Referans Nr.			b1	b2xL	d	e1	e2	h	
1200-50140	-	-	17	50x140	60	30	55	75	900
1200-60175	-	-	21	60x175	80	40	70	85	1600
1200-12125	12	M12x12x125	17	50x140	60	30	55	0-50	1070
1200-14125	14	M12x14x125	17	50x140	60	30	55	0-55	1080
1200-16160	16	M16x16x160	17	50x140	60	30	55	0-75	1270
1200-18160	18	M16x18x160	17	50x140	60	30	55	0-75	1280
1200-20200	20	M20x20x200	21	60x175	80	40	70	0-85	2300
1200-22200	22	M20x22x200	21	60x175	80	40	70	0-85	2370



Ürün Nr. 1200 S-Bağlama Pabucu

- Malzeme: Dövme Çelik
- Sertleştirilmiş
- Çinko Kaplama

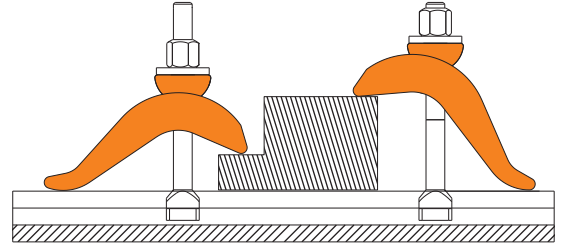
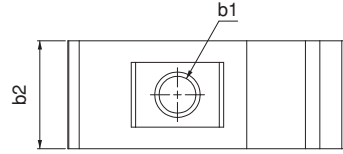
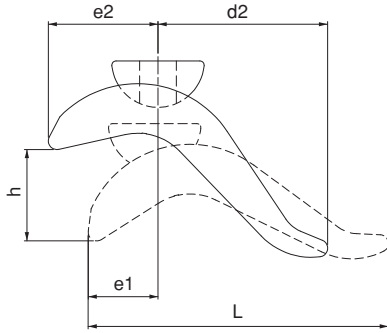

Product Nr. 1200 S-Connecting Lugs

- Material: Forged Steel
- Hardened
- Zinc Coating

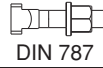

Kademeli Bağlama Pabucu

Stepped Coupling Clamp

Referans Nr.	b1			m	h	b x L	c	d	e1	k x3	
1205-017	17	16-18	-	93	15-50	65x165	39	128	30	17	2.10
1205-021	21	20-22	-	111	20-65	75x189	43	146	33	19	3.20
1205-025	25	24-28	-	126	20-75	85x213	49	164	39	21	4.50
1205-031	31	36	-	143.5	20-85	95x238	56	182	46	23	6.30
1205-016	17	16	M16x16x125	93	15-50	65x165	39	128	30	17	2.50
1205-018	17	18	M16x18x125	93	15-50	65x165	39	128	30	17	2.50
1205-020	21	20	M20x20x160	111	20-65	75x189	43	146	33	19	3.90
1205-022	21	22	M20x22x160	111	20-65	75x189	43	146	33	19	3.90
1205-024	25	24	M24x24x200	126	20-75	85x213	49	164	39	21	5.70
1205-028	25	28	M24x28x200	126	20-75	85x213	49	164	39	21	5.70
1205-036	31	36	M30x36x250	143.5	20-85	95x238	56	182	46	23	8.80



Ürün Nr. 1205 Kademeli Bağlama Pabucu

- Destek kullanmadan 15-85mm arası kullanım imkanı sağlar
- Malzeme: Dövme Çelik
- Sertleştirilmiş
- Çinko Kaplama

Product Nr. 1205 Stepped Coupling Clamp

- It provides using between 15-85 mm without supporting.
- Material: Forged Steel
- Hardened
- Zinc Coating

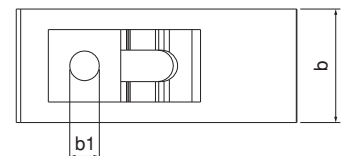
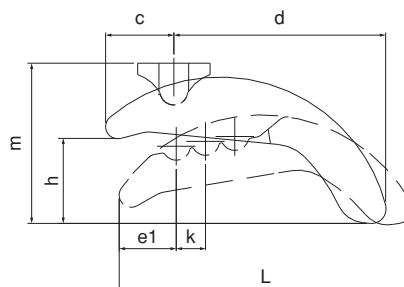

Referans Nr.	b1	a	DIN 787	m	h	b x L	c	d	e1	k x4	(g)
1210-013	13	12-14	-	52	0-40	40x90	28	48	23	14	340
1210-017	18	16-18	-	80	0-60	58x130	38	74	29	18	990
1210-021	22	20-22	-	98	0-75	68x140	46	80	32	20	1450
1210-025	26	24-28	-	110	0-90	78x175	52	100	39	24	2360
1210-012	13	12	M12x12x100	52	0-40	40x90	28	48	23	14	400
1210-014	13	14	M12x14x100	52	0-40	40x90	28	48	23	14	420
1210-016	18	16	M16x16x160	80	0-60	58x130	38	74	29	18	1140
1210-018	18	18	M16x18x160	80	0-60	58x130	38	74	29	18	1145
1210-020	22	20	M20x20x200	98	0-75	68x140	46	80	32	20	1560

Ürün Nr. 1210 Kademeli Bağlama Pabucu

- Destek kullanmadan 0-75mm arası kullanım imkanı sağlar
- Malzeme: Dövme Çelik
- Sertleştirilmiş
- Çinko Kaplama

Product Nr. 1210 Stepped Coupling Clamp

- It provides using between 0-75 mm without supporting.
- Material: Forged Steel
- Hardened
- Zinc Coating

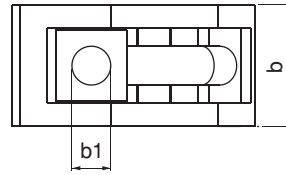
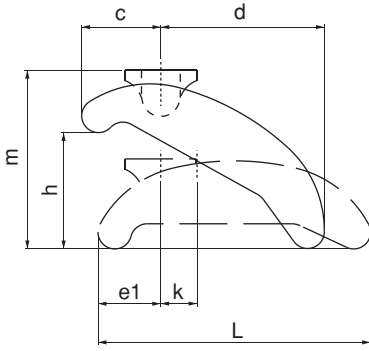

Referans Nr.	a	h min - max	f	c	L	b	(g)
1230-01	14-16-18-20-22	40 - 80	5	16	110	38	1200
1230-02		70 - 125	10	16	110	38	1490
1230-03		120 - 175	10	18	110	38	2700
1230-04		170 - 225	10	23	110	38	4260



Ürün Nr. 1230 Basamaklı Kombine Pabuç

- Pabuçun çift taraflı kullanım özelliği; basamaklı yükselticisi ile kısıtlı alanlarda kullanım avantajı sağlar.
- DIN 650 T-Kanala uyumludur.
- Pabuç malzeme: Sertleştirilmiş
- Civata 10.9 kalite
- Gövde statik boyalı diğer parçalar siyah kaplama

Product Nr. 1230 Stepped Combined Clamp

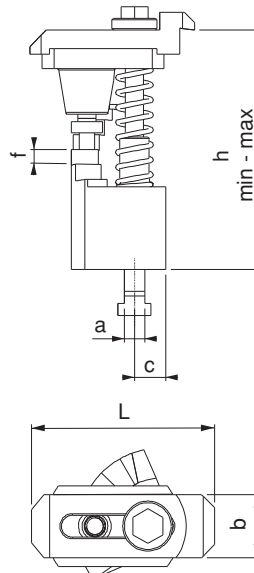
- Double-sided usage of the clamp provides using advantage in restricted areas
- Product is suitable to DIN 650 T-Slot
- Clamp Material: Hardened
- Bolt Quality: 10.9
- Body is statically painted and the other parts are black coated



Referans Nr.		h min-max	f	c	L	b	m	sw	Sıkma Kuvveti Clamping Force Kgf	Nm	 (g)
1250 - 02	14-16-18-20-22	80-137	3	17	110	38	M12	19	2250	85	2015
1250 - 03		125-224	3	17	110	38	M12	19	2250	85	2910
1250 - 04		160-300	3	17	110	38	M12	19	2250	85	3665



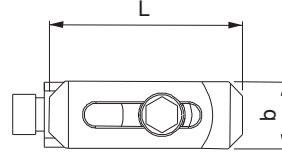

Ürün Nr. 1250 Kombine Bağlama Pabuç

- Pabucun çift taraflı kullanım özelliği; kendi içinde bulunan kademeli yükseltici desteği ile kısıtlı alanlarda kullanım kolaylığı sağlar.
- DIN 650 T-Kanala uyumludur.
- Pabuç Malzeme: Sertleştirilmiş
- Civata 10.9 kalite
- Siyah kaplama

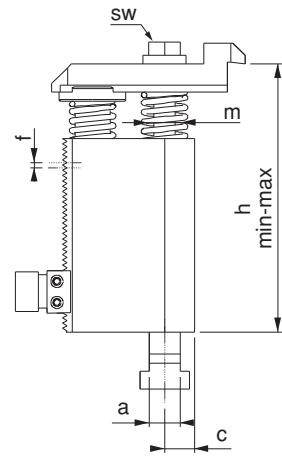
Product Nr. 1250 Combined Coupling Clamp

- Double-sided usage of the clamp and it's stepped lifter's support provides using advantage in restricted areas
- It is suitable to DIN 650 T-Slot
- Clamp Hardness: Hardened
- Bolt Quality: 10.9
- Black coating



Referans Nr.		h min-max	 DIN 787	b1	e	z	L	b	 (g)
1270-1012	12	0-45	M10x12x125	11	48	61	109	40	660
1270-1214	14	0-45	M12x14x125	13	48	61	109	40	705
1270-1416	16	0-55	M14x16x125	15	57	72	129	50	1190
1270-1618	18	0-55	M16x18x125	17	57	72	129	50	1265

Desteksiz Askı Pabuç

Unsupported Suspension Clamp

Ürün Nr. 1270 Desteksiz Askı Pabuç

- Destek kullanmadan 0-55 mm arası kullanım imkanı sağlar.
- Malzeme: Dövme çelik
- Pabuç Malzeme: Sertleştirilmiş
- Civata 12.9 kalite
- Çinko Kaplama

Product Nr. 1270 Unsupported Suspension Clamp

- Product provides using between 0-55 mm without using support
- Material: Forged Steel
- Clamp Hardness: Hardened
- Bolt Quality: 12.9
- Zinc Coating

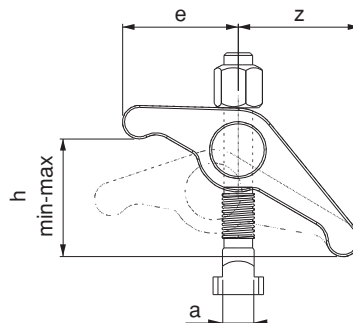
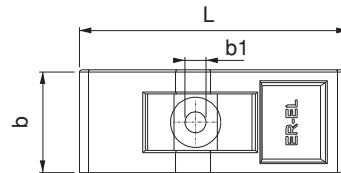

Referans Nr.	a	b	c	d	e	m	sw	m1	İmbus	sıkma kuvveti clamping force Kgf	Tork Değeri Allowable Screw Torque (N-m)	(g)
1275-3012	30	28	16	40	23	M12	30	M8	M10	750	20	300
1275-5012	50	32	20	45	40	M12	36	M12	M12	1000	30	500
1275-5016	50	32	20	45	40	M16	36	M12	M12	1000	30	510
1275-6016	60	40	25	45	45	M16	41	M16	M16	1250	45	750



Ürün Nr. 1275 Kombine Burçlu Pabuç

- Kısıtlı alanlarda çalışma özelliği
- Sertleştirilmiş
- Siyah kaplama

Product Nr. 1275 Combined Clamp With Bush

- Function working in restricted areas
- Hardened
- Black coated

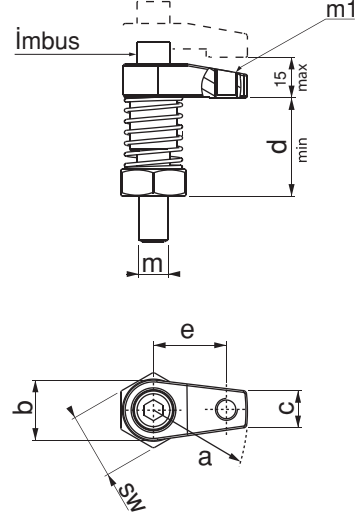
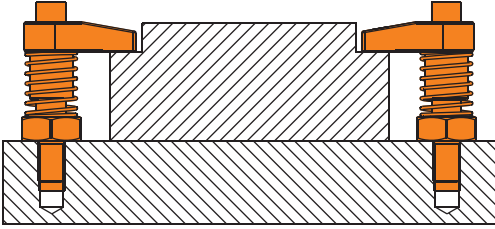

Kombine Burçlu Pabuç

Referans Nr.	a	Ø b h7	c	d	e	f	g	m	m1	j	sıkma kuvveti clamping force Kgf	(g)
1280-3010	30	22	58	80	28	16	30	M10	M8	23	750	220
1280-5012	50	26	70	90	32	20	40	M12	M12	40	1100	400
1280-6016	60	32	74	95	40	25	40	M16	M16	45	1250	610



Ürün Nr. 1280 Kombine Burçlu Pabuç

- Kısıtlı alanlarda çalışma özelliği
plaka üstüne uygulama seçeneği
- Sertleştirilmiş
- Siyah kaplama

Product Nr. 1280 Combined Clamp With Bush

- Function working in restricted areas and
variety application at plate
- Hardened
- Black coated

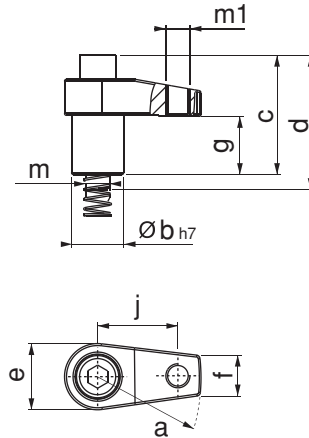

Referans Nr.	a (F7)	b	c	m
1280-3010	22	30	20	M10
1280-5012	26	40	25	M12
1280-6016	32	40	25	M16

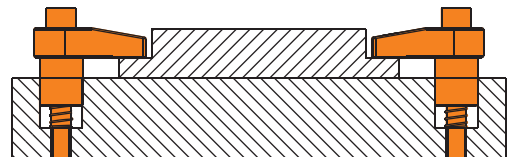
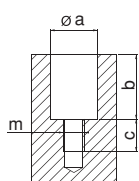

Referans Nr.	a	b	m	d	sw	 (g)
1282-0825	25	12	M8	8	14	10
1282-1030	30	17	M10	10	17	30
1282-1235	35	22	M12	12	22	60
1282-1642	42	26	M14	14	27	125



Ürün Nr. 1282 Oynar Başlı Baskı Pabucu

- Dereceli temiz yüzeyler için
- Nr.1275 ve 1280 ürünlerle uyumludur.
- Sertleştirilmiş
- Siyah kaplama

Product Nr. 1282 Moving Head Press Clamp

- Graded clean surfaces.
- It is applicable with Nr. 1275 and 1280
- Hardened
- Black coated

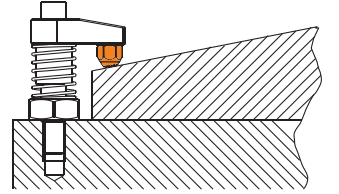
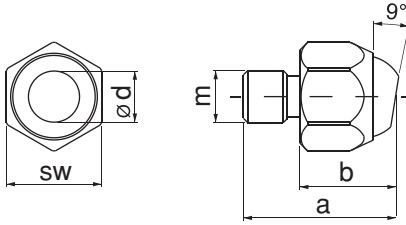

Oynar Başlı Baskı Pabucu (Uzun)

Pivoting Head Pad Printing (Long)

Referans Nr.	D1	D2	L	L1	SW	 (g)
1282-25D	M8	8	36.6	25	13	26
1282-30D	M10	10	45.7	30	17	42
1282-35D	M12	12	50.7	35	17	53
1282-40D	M16	14	60.7	40	24	117
1282-50D	M20	14	77.3	50	30	240



Ürün Nr. 1282 Oynar Başlı Baskı Pabucu (Uzun)

- Dereceli temiz yüzeyler için
- Nr.1275 ve 1280 ürünlerle uyumludur.
- Sertleştirilmiş
- Siyah kaplama

Product Nr. 1282 Moving Head Press Clamp (Long)

- Graded clean surfaces.
- It is applicable with Nr. 1275 and 1280
- Hardened
- Black coated

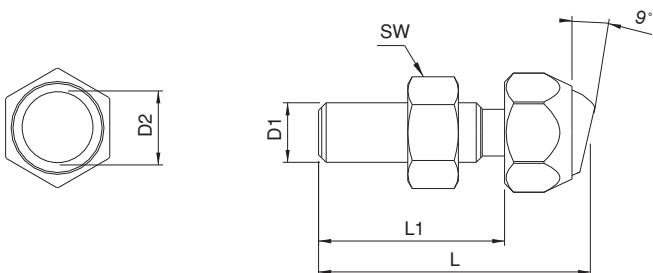

Referans Nr.	a	b	m	d	sw	(g)
1283-0825	25	12	M8	8	14	10
1283-1030	30	17	M10	10	17	30
1283-1235	35	22	M12	12	22	60
1283-1642	42	26	M14	14	27	120



Ürün Nr. 1283 Oynar Başlı Baskı Pabucu

- Dereceli ve bozuk yüzeyler için baskı yüzeyi tırtıllı olarak tasarlanmıştır.
- Sertleştirilmiş
- Siyah kaplama

Product Nr. 1283 Moving Head Press Clamp

- Its clamping surface is designed with bead graded bad surfaces.
- Hardened
- Black coated

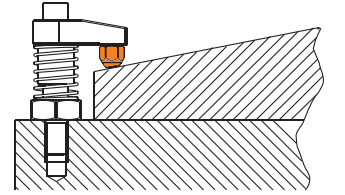
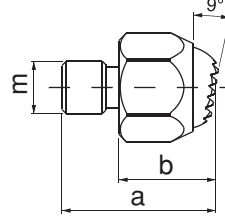
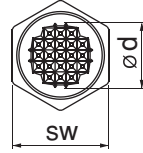

Oynar Başlı Baskı Pabucu (Uzun)

Referans Nr.	D1	D2	L	L1	SW	(g)
1283-25T	M8	8	36.6	25	13	26
1283-30T	M10	10	45.7	30	17	42
1283-35T	M12	12	50.7	35	17	53
1283-40T	M16	14	60.7	40	24	117
1283-50T	M20	14	77.3	50	30	240



Ürün Nr. 1283 Oynar Başlı Baskı Pabucu (Uzun)

- Dereceli ve bozuk yüzeyler için baskı yüzeyi tırtıllı olarak tasarlanmıştır.
- Nr.1275 ve 1280 ürünlerle uyumludur.
- Sertleştirilmiş
- Siyah kaplama

Product Nr. 1283 Moving Head Press Clamp (Long)

- Its clamping surface is designed with bead graded bad surfaces.
- It is applicable with Nr. 1275 and 1280
- Hardened
- Black coated

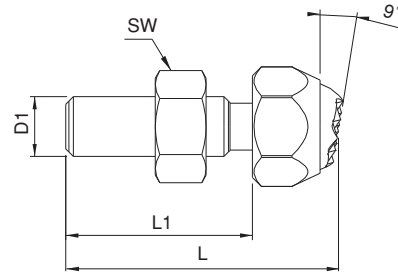

Yükseltme Kovanı

Referans Nr.	a	b F7	c	d	e	f	m	h	(g)
1285-12080	80	26	36	40	110	M12	M12	40	600
1285-12100	100	26	36	40	130	M12	M12	40	795
1285-16080	80	32	46	50	110	M16	M16	40	945
1285-16100	100	32	46	50	130	M16	M16	40	1230





Ürün Nr. 1285 Yükseltme Kovanı

- Nr.1280 ürün ile yüksek parça bağlamalarda kullanılır
- Sertleştirilmiş
- Siyah kaplama

Product Nr. 1285 Support to The Hive

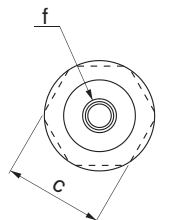
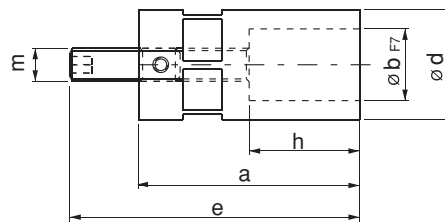
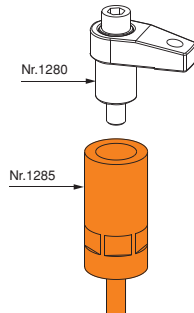
- It is used together with Nr. 1280 for clamping high pieces.
- Hardened
- Black coated



Referans Nr.	a ($\begin{smallmatrix} 0 \\ -0.13 \end{smallmatrix}$)	b	 (g)
1287-CT9120	12	7.8	13

Ürün Nr. 1287 Baskı Pabucu

- Sertleştirilmiş
- Siyah kaplama

Product Nr. 1287 Pressure Pad

- Hardened
- Black coating

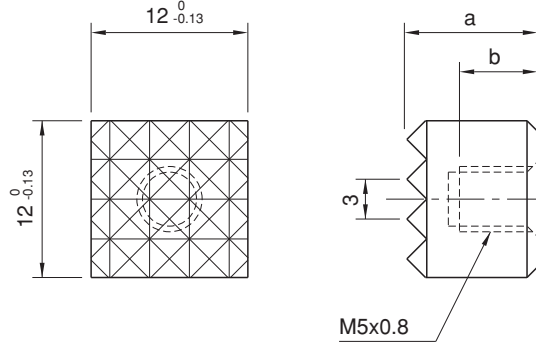

Referans Nr.	a ($\begin{smallmatrix} 0 \\ -0.13 \end{smallmatrix}$)	b ($\begin{smallmatrix} 0 \\ -0.13 \end{smallmatrix}$)	d	p	 (g)
1287-HS9102	10	12	M5x0.8	2.3	7.5
1287-HS9122	12	12	M5x0.8	3	11
1287-HS9160	16	12	M6x1	3	17
1287-HS9202	20	12	M5x0.8	3	33.5
1287-HS9252	25	12	M6x1	3	53

Ürün Nr. 1287 Baskı Pabucu

- Sertleştirilmiş
- Siyah kaplama

Product Nr. 1287 Pressure Pad

- Hardened
- Black coating

Baskı Pabucu

Pressure Pad

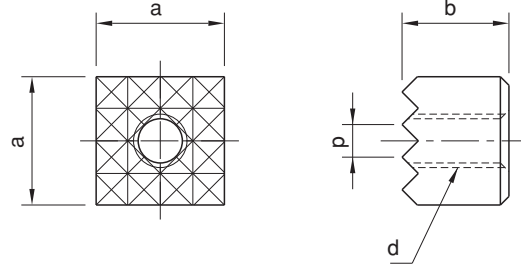

Referans Nr.	a ($\begin{smallmatrix} 0 \\ -0.13 \end{smallmatrix}$)	b ($\begin{smallmatrix} 0 \\ -0.13 \end{smallmatrix}$)	c	d	 (g)
1287-HS9122C	12	12	6.5	M4	10
1287-HS9160C	16	12	4.5	M4	16
1287-HS9202C	20	12	5.5	M5	31
1287-HS9252C	25	12	4.5	M6	49

Ürün Nr. 1287 Baskı Pabucu

- Sertleştirilmiş
- Siyah kaplama

Product Nr. 1287 Pressure Pad

- Hardened
- Black coating

Baskı Pabucu

Pressure Pad

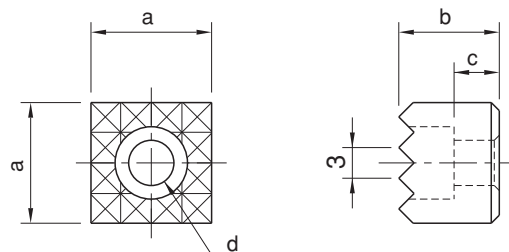

Referans Nr.	a ($\begin{smallmatrix} 0 \\ -0.13 \end{smallmatrix}$)	b ($\begin{smallmatrix} 0 \\ -0.13 \end{smallmatrix}$)	c	d	f	g	p	 (g)
1288-CT102	10	12	6	7.9	M5x0.8	8	2.3	6
1288-CT122	12	12	6	9.5	M5x0.8	8	3	9
1288-CT162	16	12	6	12.7	M6x1	7.8	3	17
1288-CT202	20	12	6	15.9	M6x1	7.8	3	28
1288-CT252	25	12	6	19.1	M6x1	7.8	3	43

Ürün Nr. 1288 Baskı Pabucu

- Sertleştirilmiş
- Siyah kaplama

Product Nr. 1288 Pressure Pad

- Hardened
- Black coating

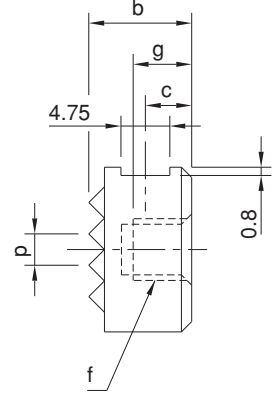
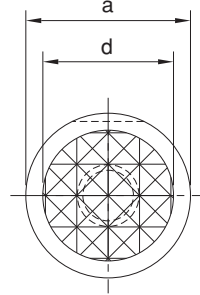
Baskı Pabucu

Referans Nr.	a ($\begin{smallmatrix} 0 \\ -0.13 \end{smallmatrix}$)	b ($\begin{smallmatrix} 0 \\ -0.13 \end{smallmatrix}$)	d	e	p	 (g)
1288-HS102	10	12	M5x0.8	6	2.3	6
1288-HS122	12	12	M5x0.8	6	3	9
1288-HS162	16	12	M6x1	6	3	15
1288-HS202	20	12	M6x1	6	3	25
1288-HS252	25	12	M6x1	6	3	40

Ürün Nr. 1288 Baskı Pabucu

- Sertleştirilmiş
- Siyah kaplama

Product Nr. 1288 Pressure Pad

- Hardened
- Black coating

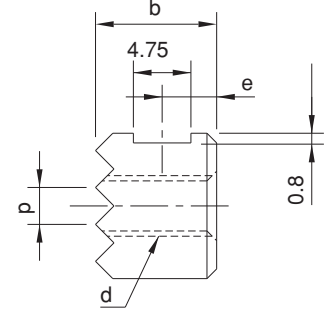
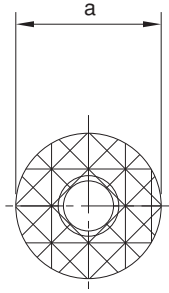
Baskı Pabucu

Referans Nr.	a ($\begin{smallmatrix} 0 \\ -0.13 \end{smallmatrix}$)	b ($\begin{smallmatrix} 0 \\ -0.13 \end{smallmatrix}$)	c	d	 (g)
1288-HS122C	12	12	6.5	M4	8
1288-HS162C	16	12	6.5	M4	15
1288-HS202C	20	12	6.5	M5	23
1288-HS252C	25	12	6.5	M6	38

Ürün Nr. 1288 Baskı Pabucu

- Sertleştirilmiş
- Siyah kaplama

Product Nr. 1288 Pressure Pad

- Hardened
- Black coating

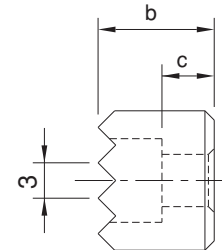
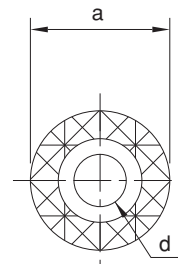

Referans Nr.	L	b1	metrik		a	b2	b3	e1	e2	g
			metrik	whitworth						
1290-06050	50	6.6	M6	1/4	10	20	8	10	20	50
1290-06080	80								30	95
1290-08060	60	9	M8	5/16	12	25	10	13	22	100
1290-08100	100								45	170
1290-10080	80	11	M10	3/8	15	30	12	15	30	190
1290-10100	100								45	225
1290-12100	100	14.5	M12-M14	1/2	20	40	14	21	45	435
1290-12125	125								55	580
1290-16125	125	18.5	M16-M18	5/8	25	50	18	26	55	855
1290-16160	160								65	1175

Ürün Nr. 1290 Merdiven Diş Bağlama Pabucu

- Nr. 1310 Merdiven destek ile kullanılır
- Sertleştirilmiş
- Siyah Kaplama

Product Nr. 1290 Serrated Thread Clamp

- Product is used with Nr. 1310 Serrated Support
- Hardened
- Black Coating

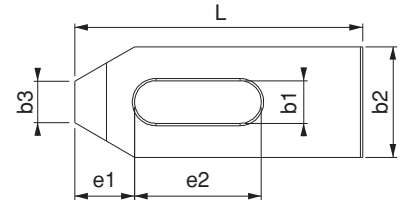
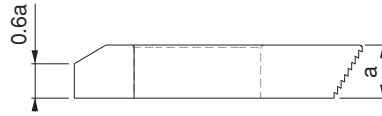

Referans Nr.	h-H	a	b	c	min-max	g
1310-01	37-85	57	35	60	0-40	505
1310-02	48-112	73	45	76	0-60	825
1310-03	58-139	90	55	93	0-75	1250
1310-04	66-165	108	64	111	0-90	685

Ürün Nr. 1310 Merdiven Diş Destek

- Nr. 1290 Merdiven diş pabucu ile kullanılır
- Siyah Kaplama

Product Nr. 1310 Serrated Thread Support

- Product is used with Nr. 1290 Serrated Thread Clamp
- Black Coating

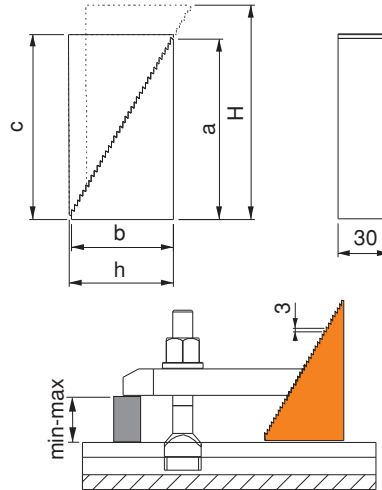

Merdiven Diş Destek

Serrated Thread Support



Referans Nr.	b1	L1	metrik		a	b2	b3	L2	L3	g
			metrik	whitworth						
1320-08100	9	100	M8	5/16	15	30	16	32	18	240
1320-10125	11	125	M10	3/8	20	30	20	38	24	380
1320-12160	14.5	160	M12-M14	1/2	25	40	24	47	30	800
1320-12200	14.5	200	M12-M14	1/2	25	40	24	47	30	950
1320-16200	18.5	200	M16-M18	5/8	30	50	28	57	36	1500
1320-16250	18.5	250	M16-M18	5/8	30	50	28	57	36	1850
1320-20250	22.5	250	M20-M22	3/4	40	60	35	68	45	2900
1320-20315	22.5	315	M20-M22	3/4	40	60	35	68	45	3600
1320-24250	26	250	M24	1	40	70	43	83	56	3400
1320-24315	26	315	M24	1	40	70	43	83	56	4300
1320-30315	33	315	M30	1 1/4	50	80	50	88	56	6000
1320-30400	33	400	M30	1 1/4	50	80	50	88	56	7300

Ürün Nr. 1320 Çatal Pabuç

- Sertleştirilmiş
- Siyah Kaplama

Product Nr. 1320 Bifurcated Clamp

- Hardened
- Black Coating

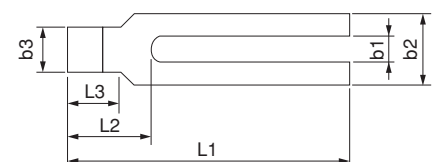

Çatal Pabuç

Bifurcated Clamp



Referans Nr.	L	b1	metrik		a	b2	b3	e1	e2	d	(g)
			metrik	whitworth							
1330-06050	50	6,6	M6	1/4	10	20	8	10	20	M8	50
1330-08060	60	9	M8	5/16	12	25	10	13	22	M8	105
1330-10080	80	11	M10	3/8	15	30	12	15	30	M10	210
1330-12100	100	14,5	M12-M14	1/2	20	40	14	21	40	M12	465
1330-12125	125							21	50		590
1330-16125	125	18,5	M16-M18	5/8	25	50	18	26	45	M16	930
1330-16160	160							26	65		1200
1330-20160	160	22,5	M20-M22	3/4	30	60	22	30	60	M20	1710
1330-20200	200								80		2170
1330-20250	250								100		3885
1330-24160	160	26	M24	1	30	70	26	35	60	M24	1965
1330-24200	200								80		2920
1330-24250	250								100		3720
1330-24315	315								100		6435
1330-30250	250								33		M30
1330-30315	315	130	7665								
1330-36400	400	150	14490								

Ürün Nr. 1330 Destek Delikli Düz Pabuç

- Sertleştirilmiş
- Siyah Kaplama

Product Nr. 1330 Straight Clamp with Support Hole

- Hardened
- Black Coating

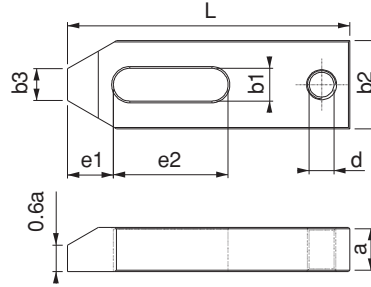

Referans Nr.	L	b1	metrik		a	b2	b3	e1	e2	(g)	
			metrik	whitworth							
1350-06050	50	6,6	M6	1/4	10	20	8	10	20	60	
1350-08060	60	9	M8	5/16	12	25	10	13	22	110	
1350-10080	80	11	M10	3/8	15	30	12	15	30	185	
1350-12100	100	14,5	M12-M14	1/2	20	40	14	21	40	480	
1350-12125	125							21	50		610
1350-16125	125	18,5	M16-M18	5/8	25	50	18	26	45	980	
1350-16160	160							26	65		1240
1350-20160	160	22,5	M20-M22	3/4	30	60	22	30	60	1795	
1350-20200	200								80		2255
1350-24200	200								26		M24
1350-24250	250	100	3875								
1350-30250	250	33	M30	1 1/4	40	80	34	45		100	
1350-30315	315							130	7885		
1350-36400	400							150	14450		

DIN 6314

Ürün Nr. 1350 Düz Pabuç

- Sertleştirilmiş
- Siyah Kaplama

Product Nr. 1350 Straight Clamp

- Hardened
- Black Coating

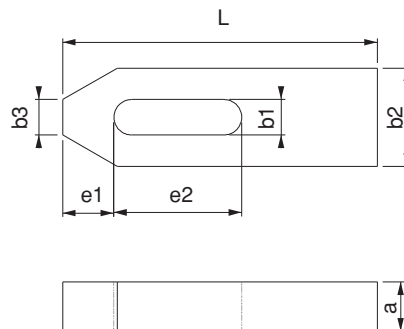

Düz Pabuç

Straight Clamp



Referans Nr.	L	b1	metrik		a	b2	a1xa2	b3	e1	e2	d	(g)
			metrik	whitworth								
1370-10080	80	11	M10	3/8	15	30	5x8	12	15	30	M10	180
1370-12100	100	14.5	M12-14	1/2	20	40	8x10	14	21	40	M12	410
1370-12125	125											590
1370-16125	125	18.5	M16-18	5/8	25	50	10x12.5	18	26	45	M16	910
1370-16160	160											1180
1370-20160	160	22.5	M20-22	3/4	30	60	12x15	22	30	60	M20	1575
1370-20200	200											2150
1370-24160	160	26	M24	1	30	70	12x15	26	35	60	M24	1800
1370-24200	200											2875
1370-24250	250											3500

Ürün Nr. 1370 Kademeli Destek Delikli Düz Pabuç

- Kısıtlı alanlarda yükseklikten kazanma amaçlı kullanılır.
- Sertleştirilmiş
- Siyah Kaplama

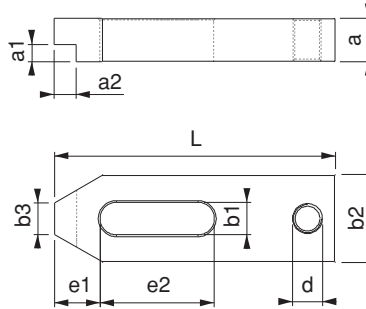
Product Nr. 1370 Straight Clamp with Stepped Support Hole

- This product is used in restricted areas with the purpose of gaining height
- Hardened
- Black Coating



Referans Nr.	L	b1	metrik		a	b2	b3	b4	(g)
			metrik	whitworth					
1390-06060	60	6.6	M6	1/4	12	19	6.2	3	65
1390-08080	80	9	M8	5/16	15	25	8	4	140
1390-10100	100	11	M10	3/8	20	30	9.5	5	240
1390-12125	125	14.5	M12-M14	1/2	25	38	12	6	700
1390-12160	160								915
1390-12200	200	18.5	M16-M18	5/8	27	48	15	8	1235
1390-16160	160								945
1390-16200	200								1215
1390-16250	250	22.5	M20-M22	3/4	37	52	20	10	2000
1390-20200	200								1650
1390-20250	250								2765
1390-20315	315								3510
1390-20500	500	26	M24	1	37	66	20	10	7200
1390-24200	200								2260
1390-24250	250								2740
1390-24315	315								3515
1390-24500	500								7100
1390-30250	250	33	M30	11/4	47	73	20	12	3500
1390-30315	315								4190
1390-30400	400								5735
1390-30600	600								8455
1390-301000	1000	40	M36	11/2	57	100	30	12	28000
1390-36400	400								10800
1390-36600	600								16500
1390-42600	600	43	M42	11/2	77	123	40	12	28800

DIN 6315B
Ürün Nr. 1390 Çatal Pabuç

- Kademeli yüzeylerde şekilli iş parçalarının bağlanmasında pabucun yapısı itibarı ile kolaylık sağlar
- Sertleştirilmiş
- Siyah Kaplama

Product Nr. 1390 Bifurcated Clamp

- Due to the structure of the clamp, this product provides convenience for the couplings of formed work pieces on graded surfaces
- Hardened
- Black Coating

Çatal Pabuç

Bifurcated Clamp

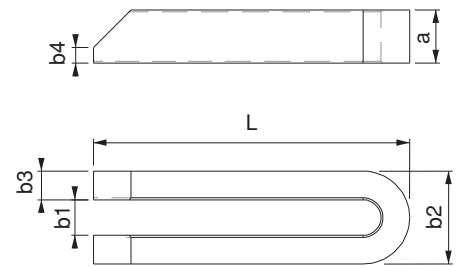

Referans Nr.	L	b1	metrik		a	b2	a1xa2	e1	e2	h	(g)
			metrik	whitworth							
1387-12070	70	13	M12	1/2	21.5	40	8x6	11	40	14	255
1387-16070	70	17	M16	5/8	29.5	40	10x7	11	40	22	290



Ürün Nr. 1387 Plaka Sıkma Pabucu

- Yükselticisiz çalışma özellięi avantajı sağlar
- Sertleştirilmiş
- Siyah Kaplama

Product Nr. 1387 Plate Sliding Clamp

- Provides the advantage of working without support.
- Hardened
- Black coated

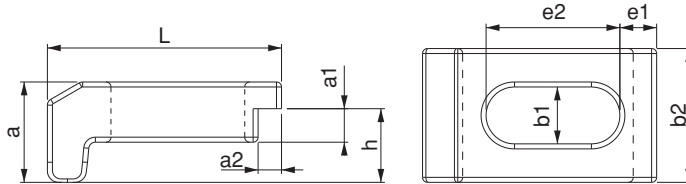

Kademeli Destek Delikli Çatal Pabuç

Bifurcated Clamp with Stepped Support Hole

Referans Nr.	L	b1	metrik		a	e2	a1xa2	b2	d	(g)
			metrik	whitworth						
1400-10100	100	11	M10	3/8	20	70	10x10	30	M10	260
1400-12125	125	14.5	M12-14	1/2	25	90	12x12	40	M12	565
1400-16160	160	18.5	M16-18	5/8	30	110	15x15	50	M16	1235
1400-20200	200	22.5	M20-22	3/4	40	135	20x20	60	M20	2460



Ürün Nr. 1400 Kademeli Destek Delikli Çatal Pabuç

- Sertleştirilmiş
- Siyah Kaplama

Kademeli ve kısıtlı alanlarda kullanım avantajı sağlar.

It provides usage advantage in gradual and limited areas.

Product Nr. 1400 Bifurcated Clamp with stepped support Hole

- Hardened
- Black Coating

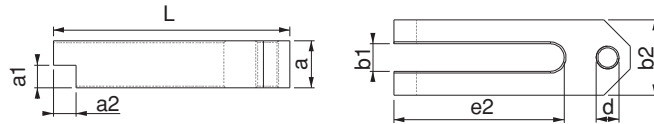

Destek Delikli Çatal Pabuç

Bifurcated Clamp with Support Hole

Referans Nr.	L	b1	metrik		a	e1	e2	b2	d	(g)
			metrik	whitworth						
1410-10100	100	11	M10	3/8	20	5	70	30	M10	260
1410-12125	125	14.5	M12-14	1/2	25	6	90	40	M12	560
1410-16160	160	18.5	M16-18	5/8	30	8	110	50	M16	1230
1410-20200	200	22.5	M20-22	3/4	40	10	135	60	M20	1490



Ürün Nr. 1410 Destek Delikli Çatal Pabuç

- Sertleştirilmiş
- Siyah Kaplama

Kademeli parçalarda ileri sıkmalarda hareket ve kullanım avantajı sağlar.

It provides usage advantage for gradual parts during forward tightenings.

Product Nr. 1410 Bifurcated clamp with support hole

- Hardened
- Black Coating

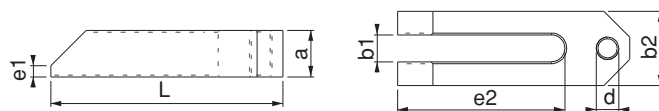

Referans Nr.	L	b1	metrik		a	a2	b2	b3	c	e1	e2	d	
			metrik	whitworth									
1450-06060	60	6.6	M6	1/4	10	20	20	10	8	20	20	M8	80
1450-08080	80	9	M8	5/16	12	24	25	12	9	25	25	M8	170
1450-10100	100	11	M10	3/8	15	30	30	15	12	32	32	M10	245
1450-12125	125	14.5	M12-M14	1/2	19	40	38	20	16	40	40	M12	600
1450-16125	125	18.5	M16-M18	5/8	24	50	48	25	20	49	40	M16	925
1450-16160	160									50	50		1205
1450-20160	160	22.5	M20-M22	3/4	29	58	58	30	24	55	55	M20	1705
1450-20200	200									70	70		2145
1450-24160	160									53	55		2110
1450-24200	200	26	M24	1	33	70	70	35	28	72	60	M24	3070
1450-24250	250									72	80		3710
1450-30250	250	33	M30	1 1/4	38	80	77	40	40	91	80	M24	4635
1450-30315	315				48	100				100	100		7050

DIN 6316

Ürün Nr. 1450 Destek Delikli Z-Bağlama Pabucu

- Yükseklikten kazanma ve somun geçişlerinde avantaj sağlar
- Sertleştirilmiş
- Siyah Kaplama

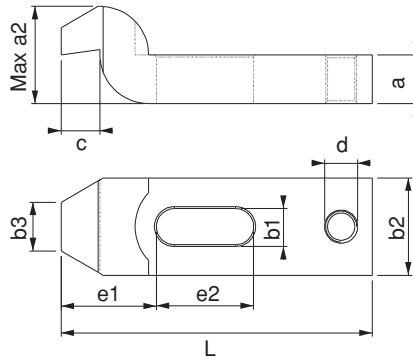

Product Nr. 1450 Z-Type Cranked Clamp with Support Hole

- This product provides advantage to gain from the height and in the passings of the bolt
- Hardened
- Black Coating



Silindir Başlı Çatal Pabuç

Forked Clamp with Pin Head

Referans Nr.	L1	b1	metrik		a	b2	Ød	L2	L3	
			metrik	whitworth						
1470-08100	100	9	M8	5/6	15	30	12	30	18	180
1470-10125	125	11	M10	3/8	20	30	16	36	24	290
1470-12160	160	14.5	M12-M14	1/2	25	40	20	45	30	715
1470-12200	200									815
1470-16200	200	18.5	M16-M18	5/8	30	50	24	55	36	1210
1470-16250	250									1550
1470-20250	250	22.5	M20-M22	3/4	40	60	30	65	45	2680
1470-20315	315									3435
1470-24250	250	26	M24	1	40	70	38	80	56	3060
1470-24315	315									4120
1470-30315	315	34	M30	1 1/4	50	80	45	85	56	5600
1470-30400	400									7135

DIN 6315C

Ürün Nr. 1470 Silindir Başlı Çatal Pabuç

- Muhtelif iş parçalarının delikli yüzeylerine girerek iş parçasını sabitler
- Sertleştirilmiş
- Siyah Kaplama

Product Nr. 1470 Forked Clamp with Pin Head

- This product fixes the work pieces by entering in the holed surfaces of various work pieces
- Hardened
- Black Coating

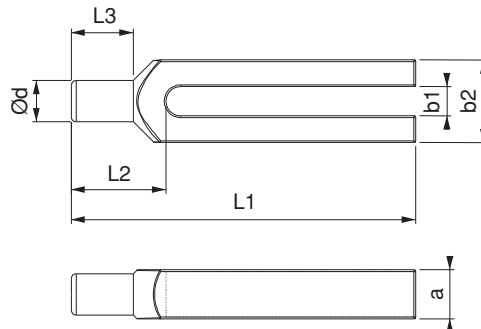

Referans Nr.		H1 - H2 (mm)	Sıkma Kuvveti Clamping Force Kgf	
1472-02530	14-16-18-20-22	25 - 30	1000	1000
1472-03035		30 - 35	1000	1150
1472-03540		35 - 40	1000	1225
1472-04045		40 - 45	1000	1245
1472-04550		45 - 50	1000	1275

Ürün Nr. 1472 Üstten Bağlama

- Sertleştirilmiş
- Siyah Kaplama

Product Nr. 1472 Above Clamping

- Hardened
- Black Coating

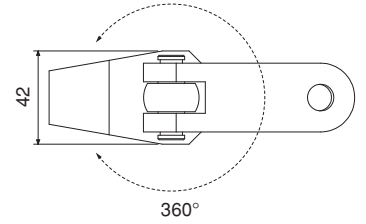
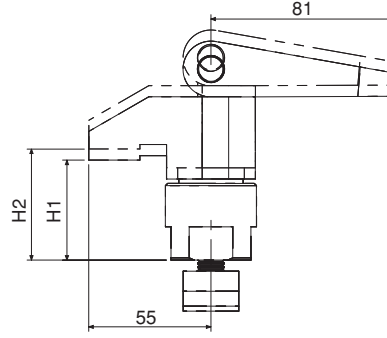
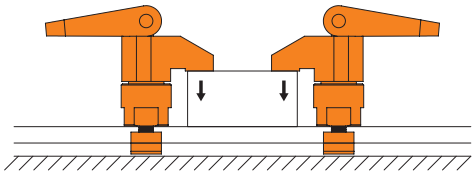

Sıkıştırma Pimi

Spring Locating Pins

Referans Nr.	P(N)	D	H (0 -1)	D1	H1	A Haraket Travel	d (+0.1 0)	
1473-06001	76	10	11	6	10.7	1	10	4
1473-08001	102	12	13	8	13.9	1.3	12	8
1473-10001	204	16	17	10	16.7	1.6	16	16
1473-06002	76	10	11	6	10.7	1	10	4
1473-08002	102	12	13	8	13.9	1.3	12	8
1473-10002	204	16	17	10	16.7	1.6	16	16



Ürün Nr. 1473 Sıkıştırma Pimi

Product Nr. 1473 Spring Locating Pins

Özellikler

- Geçici bir iş bağlama profili için idealdir.

Not

- Pimin hareket etmesi için gerekli olan minimum "P" değeri
- Parça : 90 °C'ye kadar

Features

- Ideal for temporary clamping of low-profile workpieces.

Note

- The stated value "P" denotes the minimum force needed to move the pin.
- Heat resistance : 90 °C

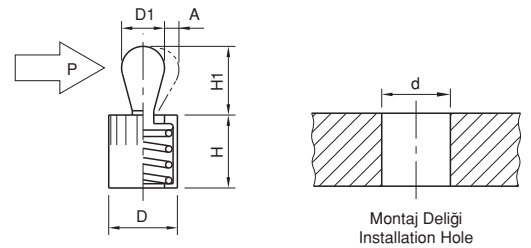

Kullanım Şekli / How To Use

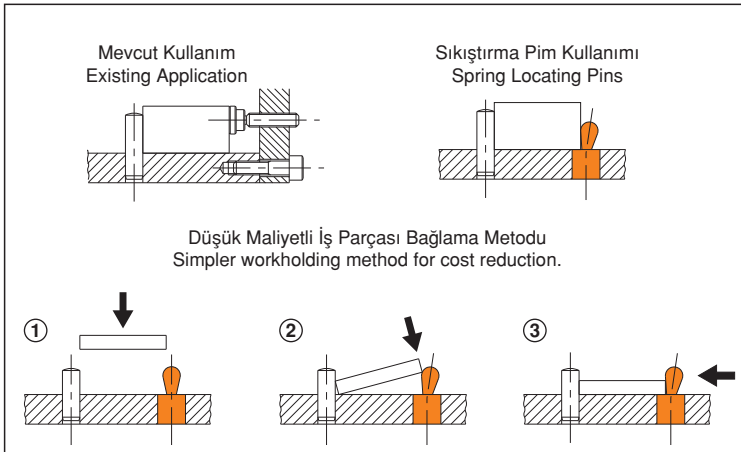

Çeşitli Uygulamalar / Application Examples

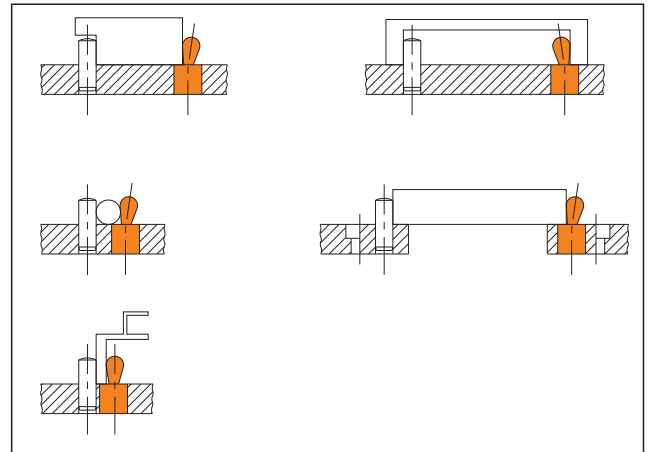

Referans Nr.	S	d (F7)	H2	D1	H (±0.01)	D	M	Dp	R
1474-06000	2	12	10	28	50	65	M8	40	160
1474-08000	2.5	16	12	34	63	80	M10	50	180

Referans Nr.	D2	H1	İzin Verilen Yük (N) Allowable Operating Load (N)	Sıkma Kuvveti Clamping Force Kgf	Önerilen Kalınlık Toleransı Recommended Workpiece Thickness Tolerance	(kg)
1474-06000	26	36	600	600	±0.5	1.2
1474-08000	28	45	600	800	±0.8	2.2

Ürün Nr. 1474 Tek Dokunuş Pimli Bağlama

- Siyah Kaplama

Product Nr. 1474 Pull Clamps

- Black coated

Not

- Pimler ve çektirme civataları ayrıca sipariş edilir.

Note

- Clamping Pins or Screws must be ordered separately.

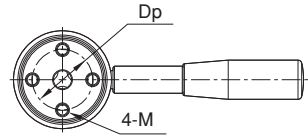
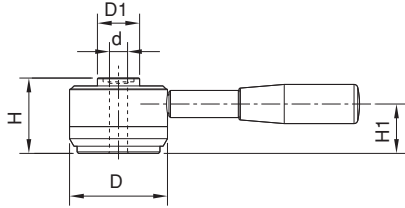

Kol, üç ayrı noktadan bağlanabilir. Bağlama pozisyonu 3 opsiyonlu.

The handle can be removed by loosening the locking screw. To keep the handle mounted permanently, make sure that the locking screw is fully tightened. 3 options of handle mounting position.

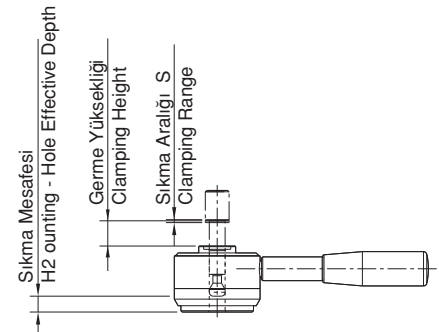
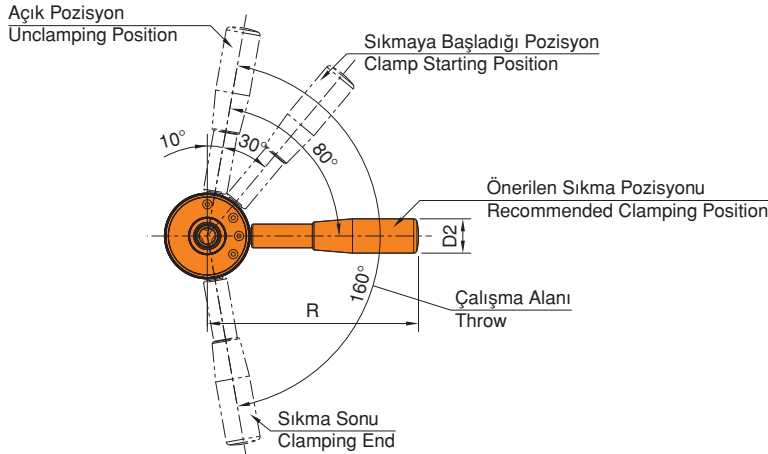
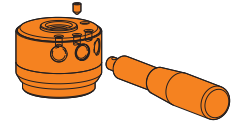

Referans Nr.	D2 (f7)	D1 (f7)	L (By 0.1mm)	D	L2	L1	L3	D3	M	M1	(g)
1475-00012	12	12	0<L<100	18	23	38	21.5	6.5	M8	M8	70 ~ 160
1475-00016	16	16	0<L<100	24	23	38	21.5	6.5	M8	M8	175 ~ 265

Ürün Nr. 1475 Tek Dokunuş Bağlama Pimi

- Pim**
- Sertlik: İndüksiyon
 - Taşlama

- Kafa**
- Siyah Kaplama

Product Nr. 1475 Clamping Pins

- Shank**
- Hardness: Induction
 - Precision ground

- Head**
- Black coated



- Not**
- Talebe göre üretim.

- Note**
- Custom Clamping Pins are available on request.

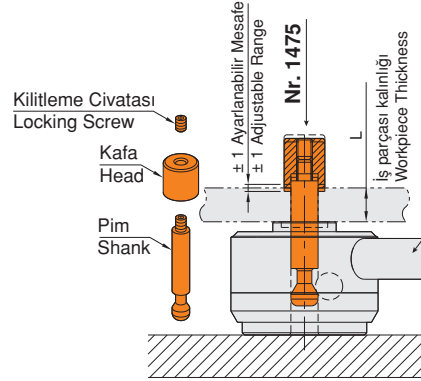
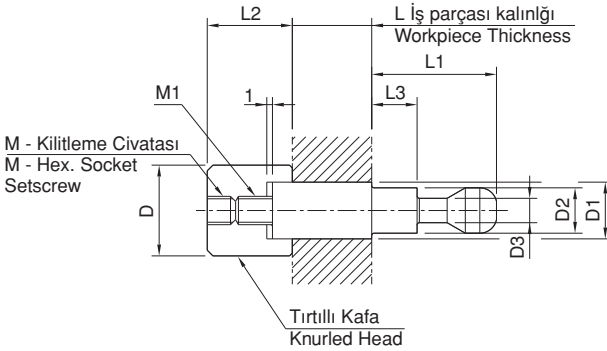

Kullanım Şekli / How To Use

Nr. 1474

L İş parçası kalınlığında ± 1 mm ayarlanabilir.
L dimension is adjustable by ± 1 mm to fit actual workpiece thickness.

Tek Dokunuş Bağlama Civatası

Clamping Screws

Referans Nr.	D1	M	L1	L	D	L2	L3	D2	W	L4	(g)
1476-00012	12	M12	13	38	20	21.5	2	6.5	10	4	40
1476-00016	12	M16	17	38	20	21.5	2	6.5	10	4	55

Ürün Nr. 1476 Tek Dokunuş Bağlama Civatası

- Siyah Kaplama

Product Nr. 1476 Clamping Screws

- Black coated



- Not**
- Özel bağlama vidalar (farklı vida boyları) istek üzerine üretim yapılır.

- Note**
- Custom Clamping Screws (different screw thread sizes) are available on request.

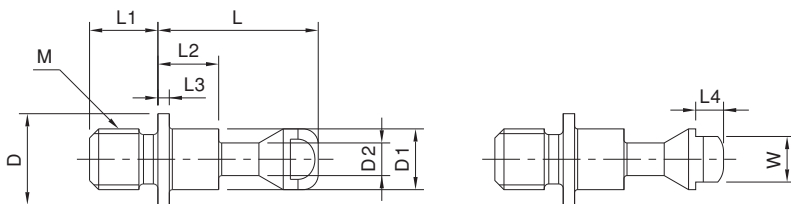

Çektirme civataları önerilen aralık toleransında olmalı
Recommended Spacing Tolerance in Use of Clamping Screws

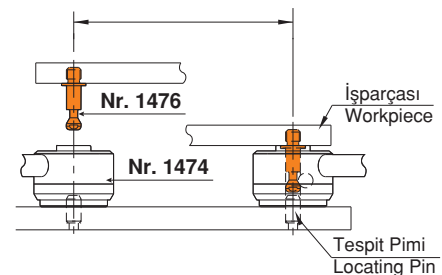

Referans Nr.	Sıkma Kuvveti Clamping Force Kgf	Tork N-m	(kg)
1477-00012	1200	40	2.3

Ürün Nr. 1477 Pimli Bağlama

Product Nr. 1477 Power-tool Actuated Block Pull Clamps

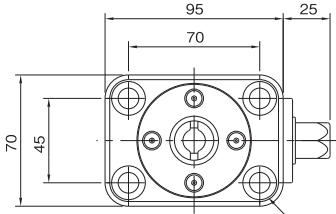

Sabitleme Civata Yeri For M10 Cap Screws

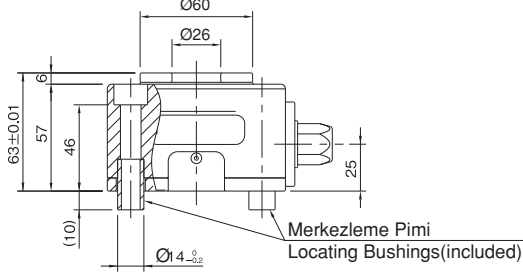

Merkezlleme Pimi Locating Bushings(included)

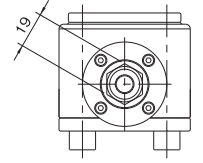

1. 5 Eksen İşleme için İdeal Kullanım
İş parçasının bütün açık yüzeylerini işleme olanağı sağlar.

1. Ideal for 5-Axis Machining
Block Pull Clamps mount under a workpiece making its surfaces to be machined fully open for the cutting tool. This allows completing multiple machining processes at a time.

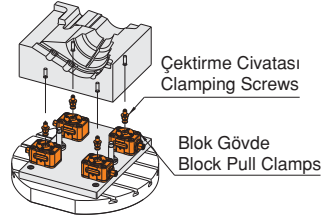

2. Daha iyi İşlenebilirlik
Blok çekme ile daha kolay iş bağlama ve klasik yöntemden daha kullanışlıdır.

2. Better Workability
Block Pull Clamps allow fastening a workpiece easily, unlike the conventional method of fastening with hexagon head screws from below.

3. Uzun Anahtar Ünite Kullanımı
Birden fazla farklı parçaları işleme olanağı sağlar.

3. Actuated Remote-Control Units
If used in conjunction with Power-Tool Actuated Remote-Control Units, Block Pull Clamps can be installed at the best possible position under the workpiece.

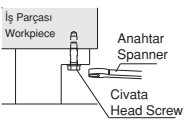

Mevcut Uygulama Conventional Method



Çektirme Civatası ile Uygulama Application with pull stud

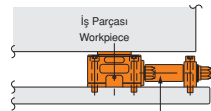

Uzun Anahtar Aktuatörü Ünitesi Power-Tool Actuated Remote-Control Unit

Kullanım Şekli / How To Use

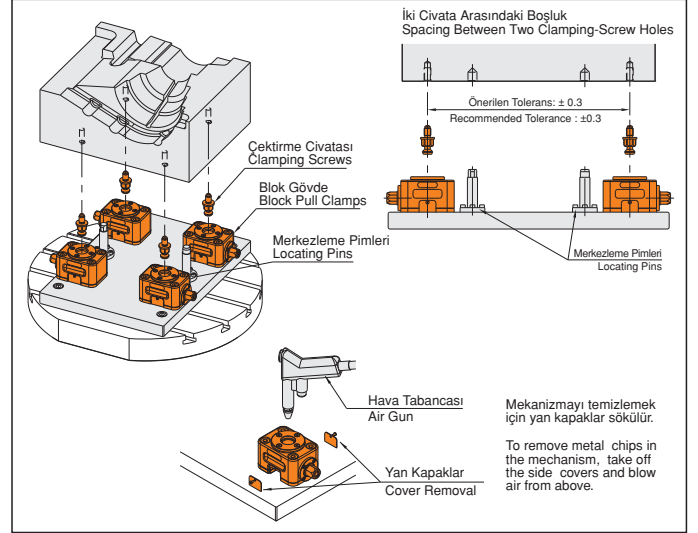

Bağlama Civatası

Clamping Screws

Referans Nr.	M	L	(g)
1478-00012	M12x	21	75
1478-00016	M16	28	98

Ürün Nr. 1478 Bağlama Civatası

- Sertleştirilmiş
- Siyah Kaplama

Product Nr. 1478 Clamping Screws

- Hardened
- Black coated

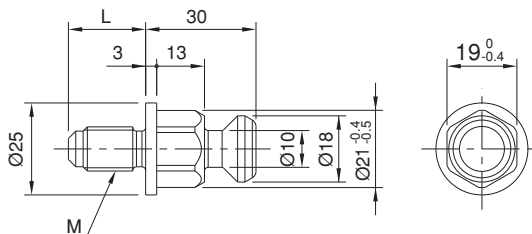

Referans Nr.	Sıkma Yüksekliği Clamping Height				Sıkma Torku Clamping Stroke	L2	L3	L1	L4	W	L	H4	B	Dp
	Finiş Yüzey Temas Finished Surface Contact		Kaba Yüzey Temas Rough Surface Contact											
	Min.	Max.	Min.	Max.										
1479-0618	21.8 (21.8-24.8)	23.8 (23.8-26.8)	21.4 (21.4-24.4)	23.4 (23.4-26.4)	3	22	6	26	11.5	36	18	6	4.3	27
1479-0823	30.3 (30.3-34.3)	32.3 (32.3-36.3)	31.2 (31.2-35.2)	33.2 (33.2-37.2)	4	30	8	35	15.3	45	23	8	5.3	34
1479-1030	30.5 (30.5-34.5)	37 (37-41)	31.5 (31.5-35.5)	38 (38-42)	4	37	8	45	20.7	65	30	12	8.4	48
1479-1240	34.5 (34.5-39.5)	44 (44-49)	37 (37-42)	46.5 (46.5-51.5)	5	45	8	55	25.4	85	40	15	10.5	64

Referans Nr.	H	D	W1	W2	H2	H1	M1	H3	W3	M	Sıkma Kuvveti Clamping Force Kgf	İzin Verilen Tork Allowable Screw Torque (N-m)	 (g)
1479-0618	56.5	18	8	4.3	10	29	M4	22.8	10	M6	230	6	94
1479-0823	73.5	23	10	5.3	14	39	M5	28.5	13	M8	360	10.5	210
1479-1030	91	30	16	8.4	18	48	M8	45.5	17	M10	600	30	515
1479-1240	114	40	20	10.4	22	58	M10	57	19	M12	750	45	1100

Ürün Nr. 1479 Dönmeli Üstten Bağlama

Gövde

- Sertleştirilmiş
- Siyah Kaplama

Sıkma Mili

- Siyah Kaplama

Product Nr. 1479 Swing Clamps For Torque Control

Body

- Hardened
- Black coated

Clamping Spindle

- Black coated

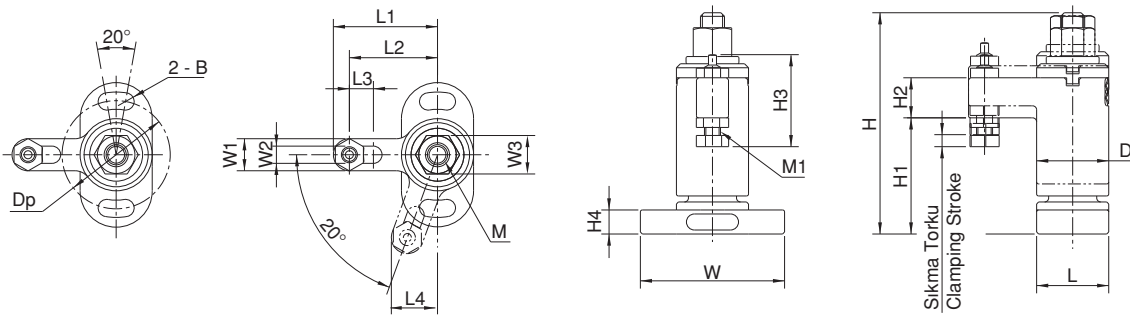

Not

- Bağlama işlemini tork anahtarları ile yapın.

Note

- Do not use a power tool (impact wrench etc.) to turn the flange nut, for damage prevention.

Kullanım Şekli / How To Use

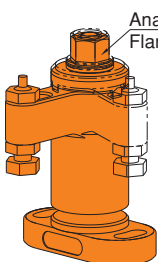

Anahtar Yeri
Flange Nut

Ürün pozisyon aldıktan sonra bağlama işlemi yapın

Turning the flange nut allows the clamp arm to swing into position for clamping.

Kaba Yüzey Temas
Rough Surface Contact

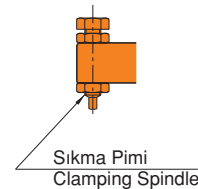

Sıkma Pimi
Clamping Spindle

Finiş Yüzey Temas
Finished Surface Contact

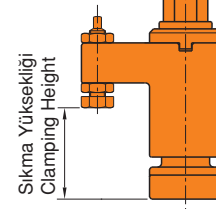

Sıkma Yüksekliği
Clamping Height

Referans Nr.	H1	S	S1	M	L2	L1	W	L	H4	d	P	H	D	W1	H2	W2	H3
1480-00012	80	10	11	M12	55	66	90	50	15	11	70	139	50	22	30	19	29
1480-00016	95	10	15	M16	65	79	100	60	20	13	80	165	60	28	35	24	35

Referans Nr.	Sıkma Kuvveti Clamping Force Kgf	Tork Değeri Allowable Screw Torque (N - m)	Sıkıştırma Yönü Clamping Direction	 (kg)
1480-00012	600	28	Saat Yönünde Clockwise	1.6
1480-00016	1000	55	Saat Yönünde Clockwise	2.9



Ürün Nr. 1480 Dönmeli Üstten Bağlama

Gövde

- Sertleştirilmiş
- Siyah Kaplama

Sıkma Pabucu

- Sertleştirilmiş
- Siyah Kaplama

Product Nr. 1480 Swing Clamps

Body

- Hardened
- Black coated

Clamping Arm

- Hardened
- Black coated

Özellikler

- Hızlı bağlama için üründe sıkma anahtarına tepkili mekanizma vardır.
- Kısa bir harekette bağlama işlemi yapar.

Features

- The clamp arm swings in swift response to the turning speed of an impact wrench, for quick clamping.
- A short clamp-arm travel allows quick clamping.

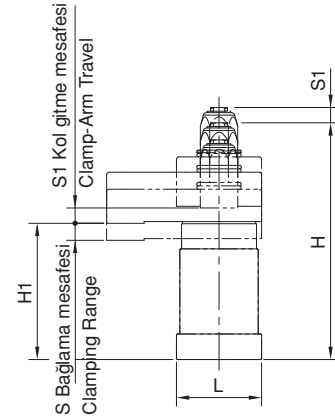
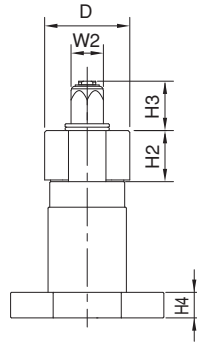
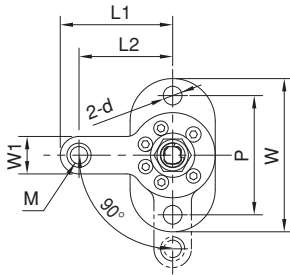

Not

- Bağlama işlemini kesinlikle tork anahtarı ile teknik tabloda verilen tork değerine uygun sıkma işlemi yapınız.

Note

- Do not use applying higher torque than allowable for a long period of time, to avoid damage. Using a torque-settable impact wrench is recommended.

Kullanım Şekli / How To Use

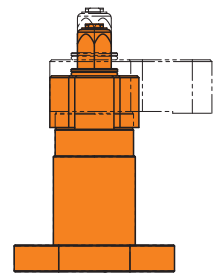
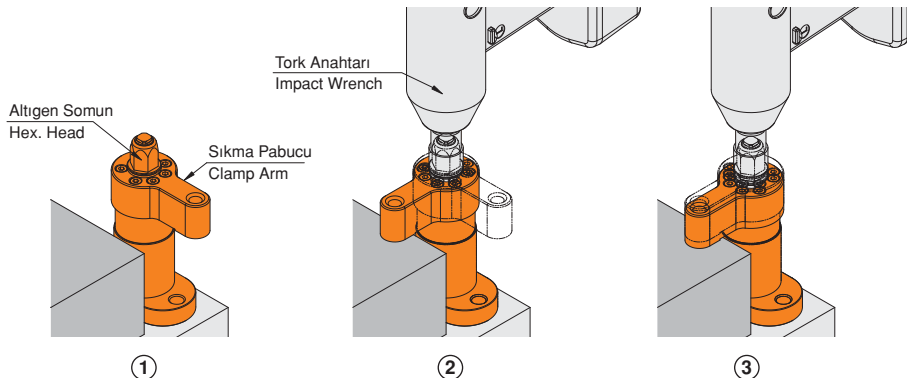

Robot hareketleri için spiral dönmeli bağlama
For robotized production lines, use Spiral-Acting Swing Clamps.

Referans Nr.	Sıkma Yüksekliği Clamping Height				Sıkma Torqu Clamping Stroke	İnme Torqu Advance Stroke	L2	L3	L1	L4	W	L	H5	B
	Finiş Yüzey Temas Finished Surface Contact		Kaba Yüzey Temas Rough Surface Contact											
	Min.	Max.	Min.	Max.										
1481-0150R	31.3	33.3	32.2	34.2	1.4	1.1	30	8	35	15.3	45	23	8	5.3
1481-0150L	(30.6-32)	(32.6-34)	(31.5-32.9)	(33.5-34.9)										
1481-0200R	32.5	39	33.5	40	1.5	1.4	37	8	45	20.7	65	30	12	8.4
1481-0200L	(31.7-33.2)	(38.2-39.7)	(32.7-34.2)	(39.2-40.7)										
1481-0300R	36.5	46	39	48.5	1.9	1.7	45	8	55	25.4	85	40	15	10.5
1481-0300L	(33.5-37.4)	(45-46.9)	(38-39.9)	(47.5-49.4)										

Referans Nr.	Dp	H	D	W1	W2	H3	H2	M	H4	R	A	H1	İzin Verilen Çalışma Yüğü Allowable Operating Load (N)	Sıkma Kuvveti Clamping Force Kgf	
1481-0150R	34	66	23	10	5.3	14	40	M5	28.5	63	20	61.3	150	180	250
1481-0150L															
1481-0200R	48	82	30	16	8.4	18	50	M8	45.5	80	26	76.5	200	220	570
1481-0200L															
1481-0300R	64	100	40	20	10.4	22	60	M10	57	100	33	93	300	350	1200
1481-0300L															

Ürün Nr. 1481 Tek Dokunuş Dönmeli Üstten Bağlama Gövde

- Sertleştirilmiş
- Siyah Kaplama

Sıkma Mili

- Siyah Kaplama

Product Nr. 1481 Swing Clamps

- Hardened
- Black coated

Clamping Spindle

- Black coated

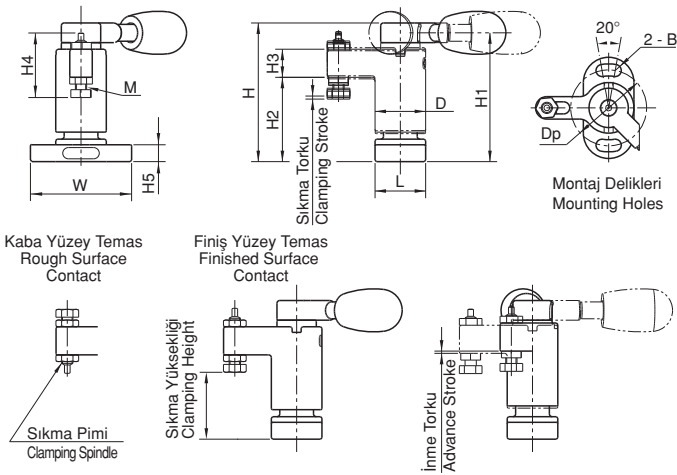

Kullanım Şekli / How To Use

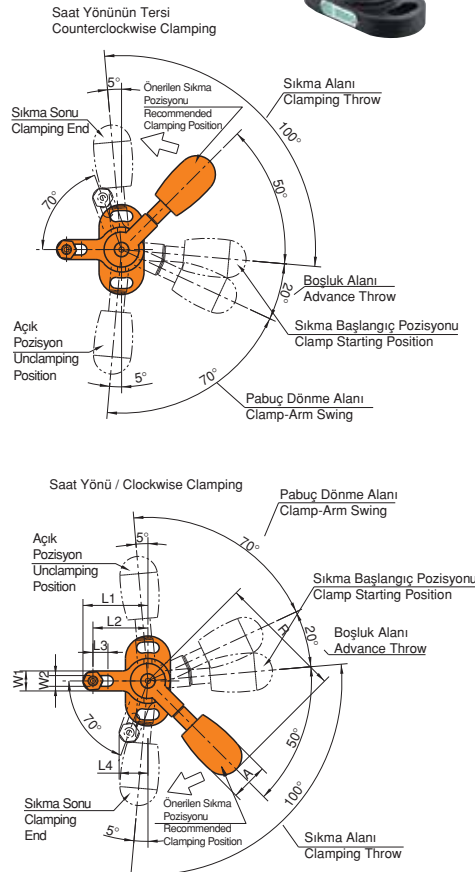
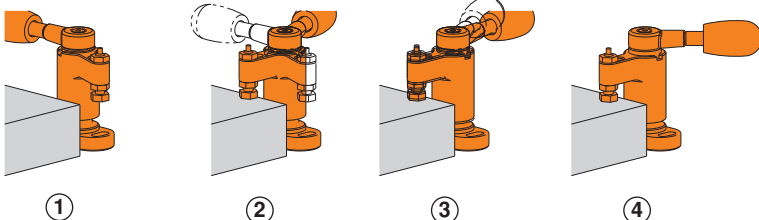

Referans Nr.	Sıkma Yüksekliği Clamping Height				Sıkma Torqu Clamping Stroke	İnme Torqu Advance Stroke	L2	L3	L1	L4	W	L	H5	B
	Finiş Yüzey Temas Finished Surface Contact		Kaba Yüzey Temas Rough Surface Contact											
	Min.	Max.	Min.	Max.										
1482-0150R	31.3	33.3	32.2	34.2	1	1.5	30	8	35	15.3	45	23	8	5.3
1482-0150L	(30.8-31.8)	(32.8-33.8)	(31.7-32.7)	(33.7-34.7)										
1482-0200R	32.5	39	33.5	40	1.2	1.8	37	8	45	20.7	65	30	12	8.4
1482-0200L	(31.9-33.1)	(38.4-39.6)	(32.9-34.1)	(39.4-40.6)										
1482-0300R	36.5	46	39	48.5	1.5	2.3	45	8	55	25.4	85	40	15	10.5
1482-0300L	(35.7-37.2)	(45.2-46.7)	(38.2-39.7)	(47.7-39.2)										

Referans Nr.	Dp	H	D	W1	W2	H3	H2	M	H4	R	A	H1	İzin Verilen Çalışma Yüğü Allowable Operating Load (N)	Sıkma Kuvveti Clamping Force Kgf	
1482-0150R	34	131	23	10	5.3	14	40	M5	28.5	63	19	68	150	150	272
1482-0150L															
1482-0200R	48	167	30	16	8.4	18	50	M8	45.5	80	24	87	200	210	625
1482-0200L															
1482-0300R	64	207	40	20	10.4	22	60	M10	57	100	30	107	300	280	1340
1482-0300L															

Ürün Nr. 1482 Tek Dokunuş Dönmeli Üstten Bağlama

Gövde

- Sertleştirilmiş
- Siyah Kaplama

Sıkma Mili

- Siyah Kaplama

Product Nr. 1482 Swing Clamps With Cam Handle

Body

- Hardened
- Black coated

Clamping Spindle

- Black coated

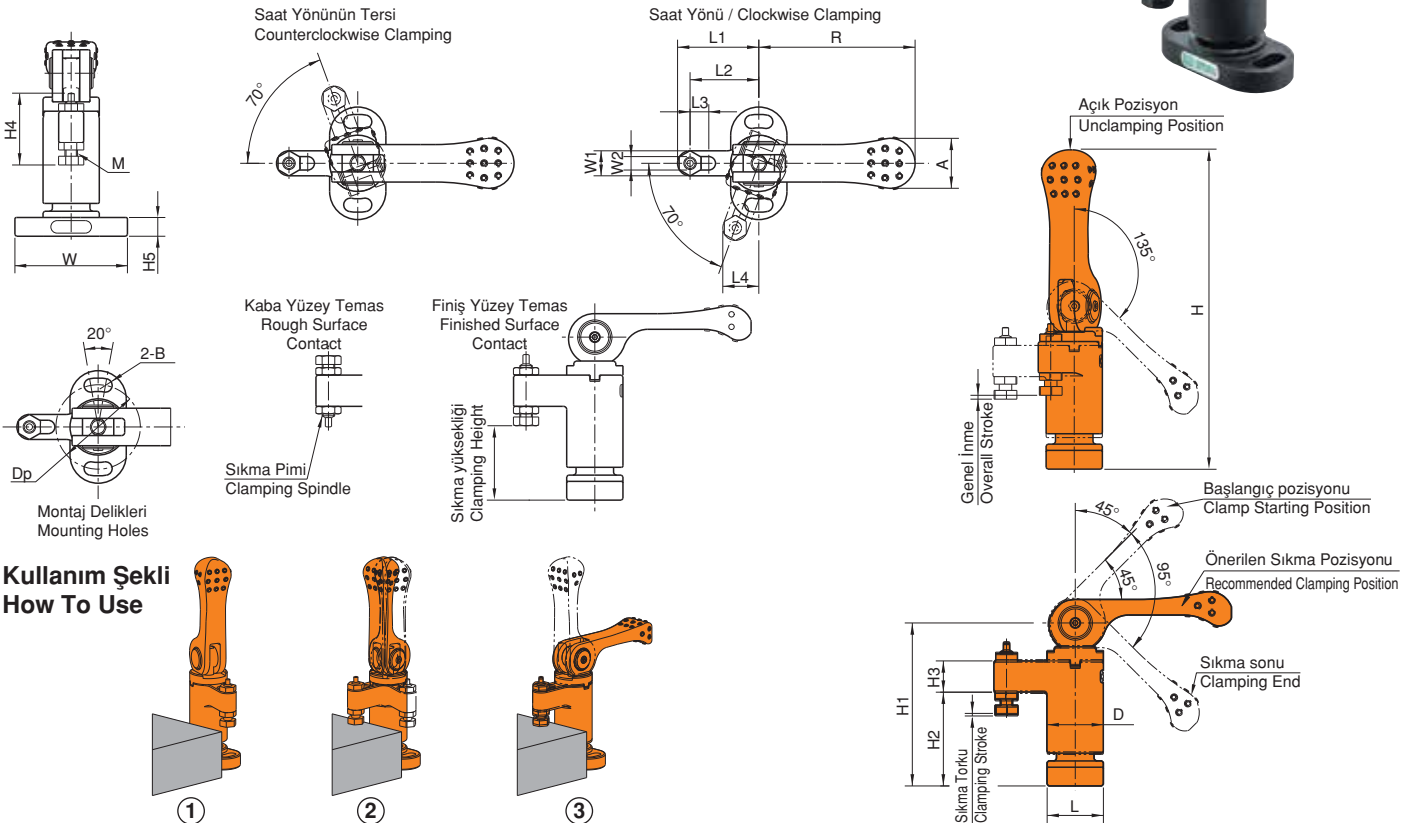

Referans Nr.	Sıkma Yüksekliği Clamping Height				Sıkma Torku Clamping Stroke	L2	L5	W	L	H4	d	P	H	L1	L3	W1
	Finiş Yüzey Temas Finished Surface Contact		Kaba Yüzey Temas Rough Surface Contact													
	Min.	Max.	Min.	Max.												
1483-03240	32 (32-29.5)	40 (40-37.5)	35 (35-32.5)	43 (43-40.5)	2.5	20	11	42	18	8	5.5	32	81	25.5	25	26
1483-03748	37 (37-33.5)	48 (48-44.5)	42 (42-38.5)	53 (53-49.5)	3.5	25	14	52	22	10	6.6	40	100	32	31	32

Referans Nr.	W2	H2	H1	M	H3	R	H5	L4	Ayarlanabilir Kol Adjustable Handles	İzin Verilen Yük (N) Allowable Operating Load (N)	Sıkma Kuvveti Clamping Force Kgf	Sıkma Mekanizması Clamping Mechanism	 (g)
1483-03240	22	10	45	M6	24	40	47	16	FKF8-BR	170	240	Vida Screw	242
1483-03748	28	12	55	M8	30.5	65	63	20	FKF8-BR	210	420	Vida Screw	490

Ürün Nr. 1483 Tek Dokunuş Üstten Bağlama

Gövde

- Sertleştirilmiş
- Siyah Kaplama

Sıkma Mili

- Siyah Kaplama

Product Nr. 1483 One-Touch Above Clamping

Body

- Hardened
- Black coated

Clamping Spindle

- Black coated

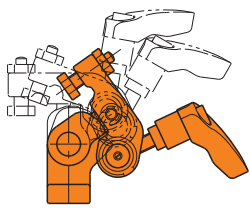
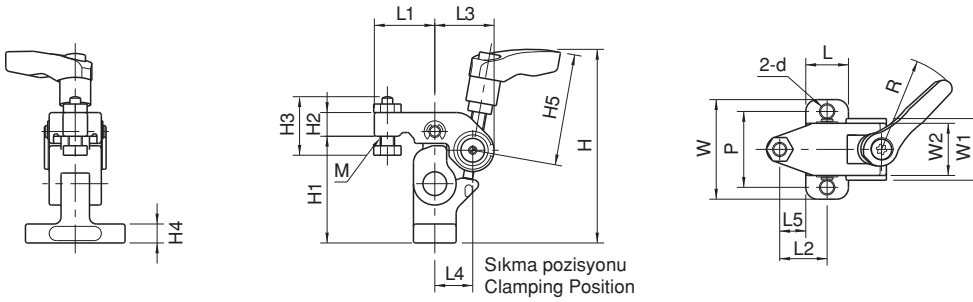

Açık Pozisyon
Unclamped

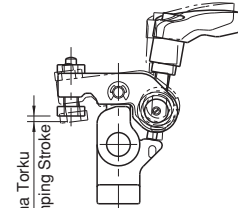
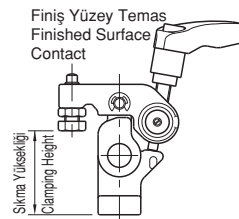
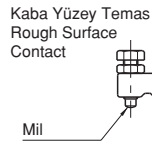

Kullanım Şekli / How To Use

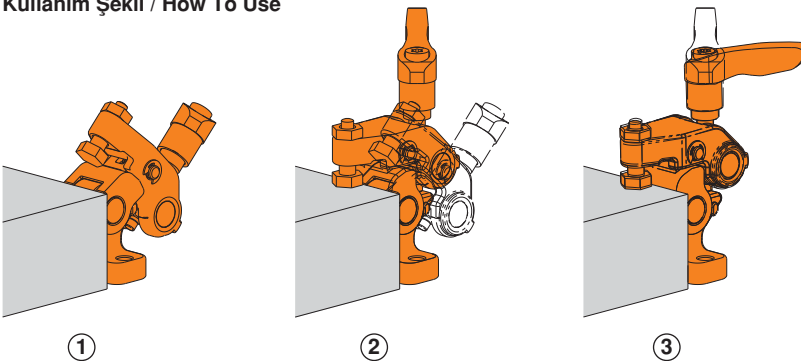

Referans Nr.	A	B	C	D	E	F	G (g6)	H	J (h6)	K	L	M	N	P (±0.02)	Q	R
1484-06501	65	57	10	47	39	70	28	12	6	5	19	M6	42	26	32	25
1484-09001	90	72	15	57	46	95	42	14	8	7	23	M8	60	36	38	28

Referans Nr.	T	U	V	W	Z	Sıkma Kuvveti Clamping Force Kgf	Tork Değeri Allowable Screw Torque (N - m)	(kg)
1484-06501	15	18	4	M4	M8	400	60	1.1
1484-09001	17	22	6	M5	M10	600	100	2.6

Ürün Nr. 1484 Dış Çap Bağlama

Product Nr. 1484 Outer Diameter Clamp

Teknik Özellikler

- Parça tekrarlama hassasiyeti: ±0.03
- Yumuşak ayak tekrarlama hassasiyeti : ±0.02

Not

- İş parçası olmadan kilit civatasını sıkmayın.
- Çeneye izin verildiğinden daha derin işlemeyin.

İçindekiler

- 1 adet kilitleme pulu
- 1 adet elmas pim
- 1 imbus civata

Technical Data

- Part locating repeatability: ±0.03
- Jaw locating repeatability: ±0.02

Notes

- Never tighten the locking screw without a part mounted, to avoid damage and deformation
- Do not machine the jaw deeper than allowed.

Included

- 1 of locking ring
- 1 of diamond pin
- 1 of socket-head cap screw

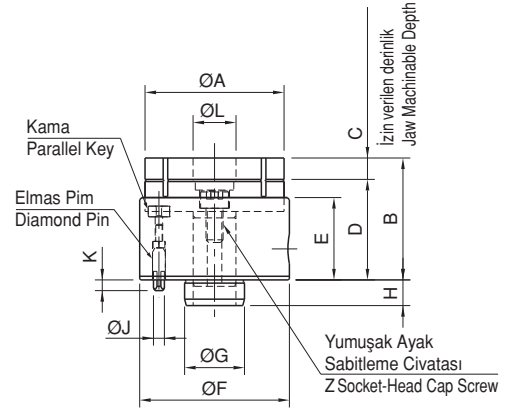
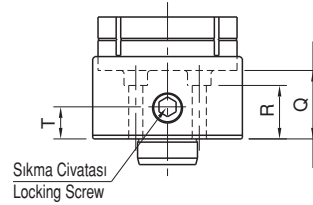
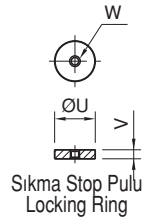
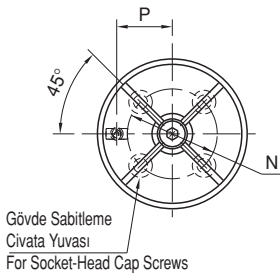

Yumuşak Ayak Jaws

Referans Nr.	A	B	C	D	E	F	G	H	J	K	(g)
1485-06501	65	25	10	15	19	28	18	4	M4	M10	170
1485-09001	90	34	15	19	23	39	22	6	M5	M12	470

Ürün Nr. 1485 Yumuşak Ayak

- Malzeme: A7075

Product Nr. 1485 Jaws

- Material: A7075

Özellik / Feature

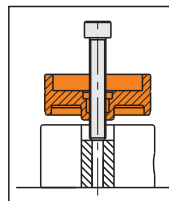
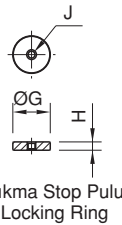
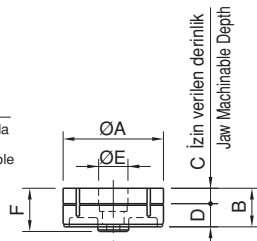
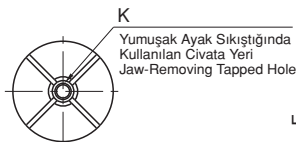
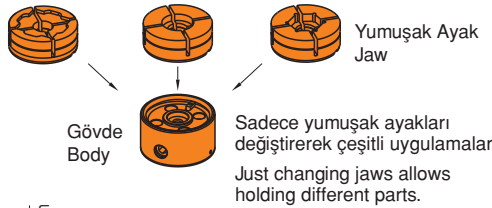

Çene Çıkarma Şekli / How To Remove Jaw

Eğer yumuşak ayak el ile çıkartılamıyorsa civata kullanınız.

When it is hard to remove the jaw by hand, screw a bolt into the jaw-removing tapped hole to push it against the body, for easier removal.

Referans Nr.	d	h (±0.01)	d1 (g6)	h1	M	h2	dp	p (±0.02)	w	h3	M1	İzin Verilen Vida Torku Allowable Screw Torque (N·m)	(kg)
1486-CP125.06501	65	25	28	12	M6	27	42	22	8	12	M8x1.25	15	0.8
1486-CP125.09001	90	30	42	14	M8	30	60	30	8	14	M10x1.5	25	1.7
1486-CP125.12001	120	35	55	18	M10	33	80	43	10	16	M10x1.5	40	3.5
1486-CP125.16001	160	40	63	24	M12	36	110	60	10	18	M12x1.75	40	7.1

Uygun Çene / Proper Jaws					
Dış Form Tutamağı İçin / For External Form Holding			İç Form Tutamağı İçin / For Internal Form Holding		
Referans Nr.	Sıkma Kuvveti Clamping Force (kN)	Sıkma Torku Clamping Torque	Referans Nr.	Sıkma Kuvveti Clamping Force (kN)	Sıkma Torku Clamping Torque
1486-CP126.06501	4.5	Ø 0.3	1486-CP127.06501	4.5	Ø 0.3
1486-CP126.09001	7		1486-CP127.09001	7	
1486-CP126.12001	10		1486-CP127.12001	10	
1486-CP126.16001	12		1486-CP127.16001	10	



Ürün Nr. 1486 İç ve Dış Çap Bağlama

- Nikel Kaplama
- Parça Tekrarlanabilirlik ±0.03
- Yumuşak Ayak Tekrarlanabilirlik ±0.03

Product Nr. 1486 Inner and Outer Diameter Clamp

- Nickel Coating
- Part locating repeatability: ±0.03
- Jaw locating repeatability: ±0.03

Not: Yumuşak Ayak Ayrı Sipariş Verilir.

Note: Jaws must be ordered separately.

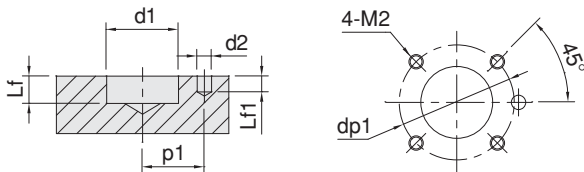
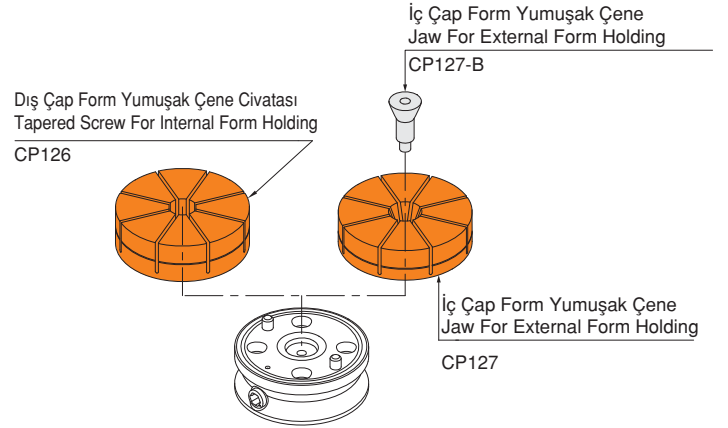
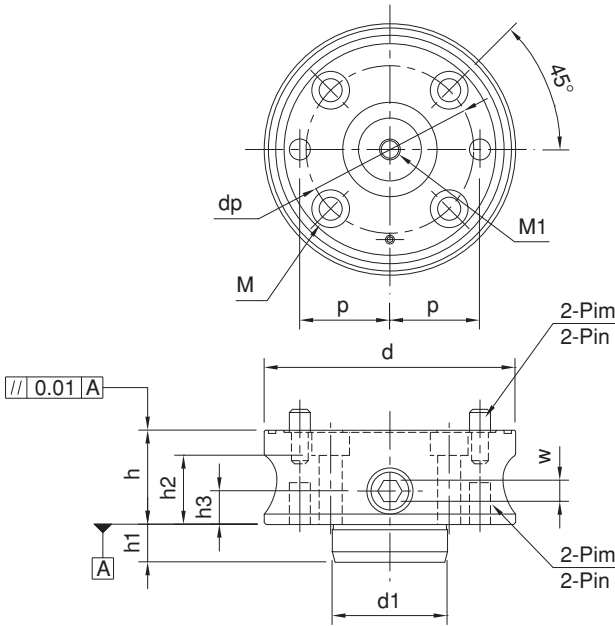

Referans Nr.	d1 (H7)	Lf	d2 (G7)	Lf1	p1 (±0.02)	M2	dp1
1486-CP125.06501	28	13	6	6	22	M 6x1	42
1486-CP125.09001	42	15	8	8	30	M 8x1.25	60
1486-CP125.12001	55	19	10	11	43	M10x1.5	80
1486-CP125.16001	63	25	12	13	60	M12x1.75	110

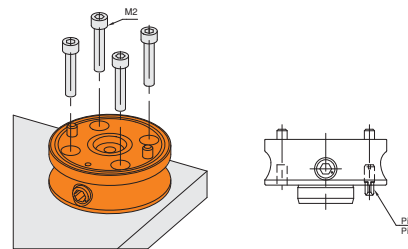

Pim Ölçüleri / Pin Dimensions

Referans Nr.	Çap Diameter
1486-CP125.06501	Ø 6h6
1486-CP125.09001	Ø 8h6
1486-CP125.12001	Ø 10h6
1486-CP125.16001	Ø 12h6

Referans Nr.	D	d	h1	h2	M	h	M	d1	t	(g)
1486-CP126.06501	65	21	25	10	M8x20	29	M5	20	4	200
1486-CP126.09001	90	25	35	15	M10x20	40	M6	24	5	500
1486-CP126.12001	120	25	40	20	M10x25	46	M6	24	5	1100
1486-CP126.16001	160	29	45	25	M12x25	52	M8	28	6	2200

Ürün Nr. 1486 Dış Çap Form Yumuşak Çene

- Malzeme: Alüminyum A7075
- Mavi kaplama
- Sıkma Torku 0.15mm

Product Nr. 1486 Outer Diameter Soft Jaw

- Material: Aluminum A7075
- Blue coating
- Clamping Torque 0.15mm

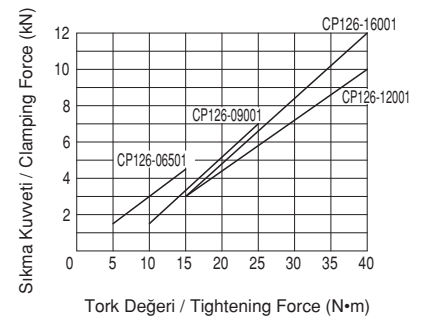
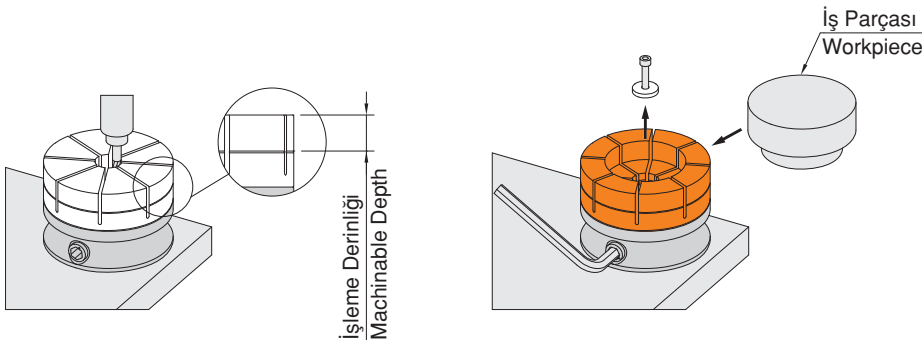
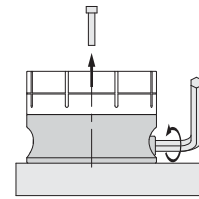
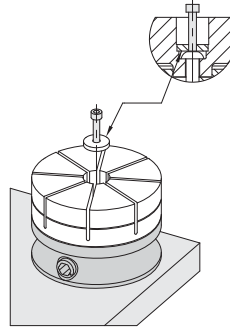
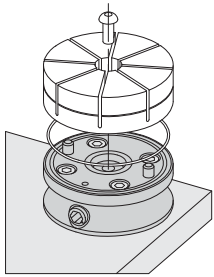
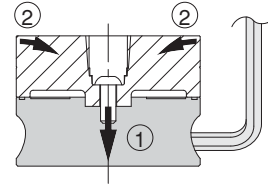
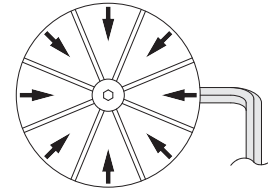
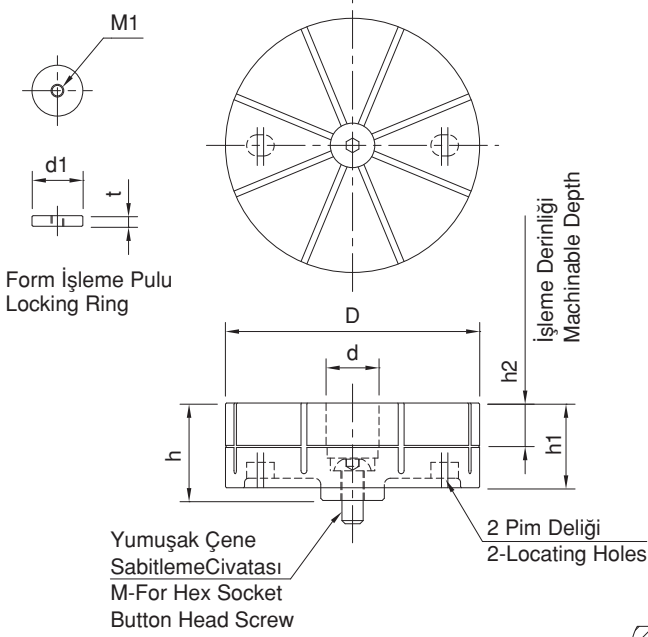

Referans Nr.	D	h1	h2	h	(g)
1486-CP127.06501	65	25	10	28.5	200
1486-CP127.09001	90	30	15	34.5	400
1486-CP127.12001	120	35	20	40.5	900
1486-CP127.16001	160	40	25	46.5	1900



Ürün Nr. 1486 İç Çap Form Yumuşak Çene

- Malzeme: Alüminyum A7075
- Gümüş kaplama
- Sıkma Torku 0.15mm

Product Nr. 1486 Inner Diameter Soft Jaw

- Material: Aluminum A7075
- Silver coating
- Clamping Torque 0.15mm

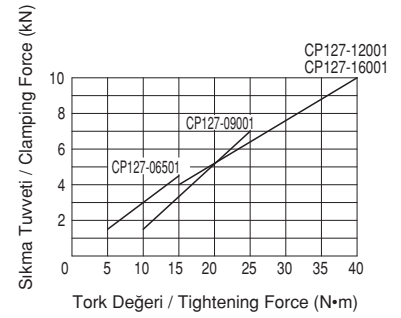
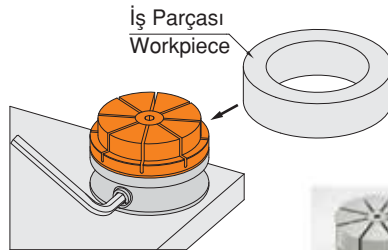
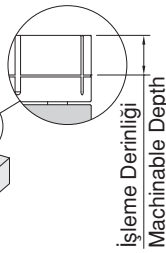
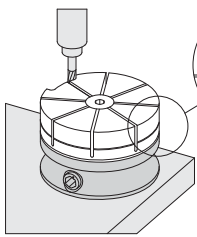
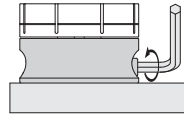
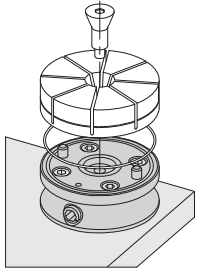
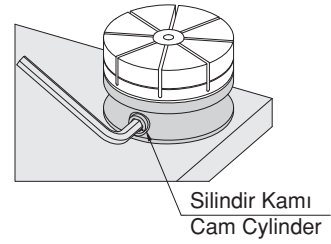
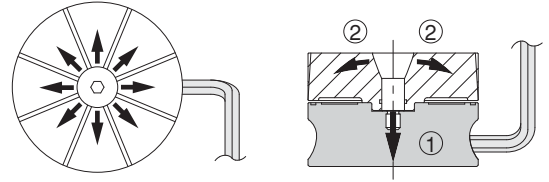
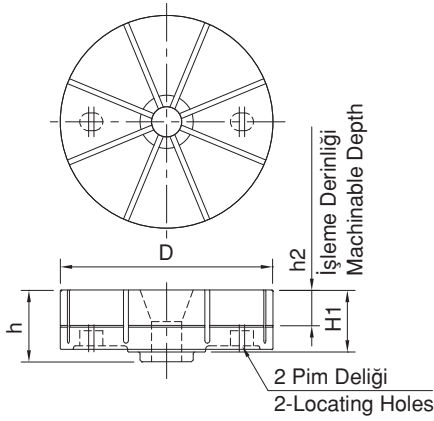

Referans Nr.	D	L	M	L1	d1	w	(g)
1486-CP127.06501B	22.5	29	M8	10	13.2	6	50
1486-CP127.09001B	27	35	M10	11	16	8	80
1486-CP127.12001B	29	41	M10	13	16	8	100
1486-CP127.16001B	33	47	M12	14	18	10	150

Ürün Nr. 1486 İç Çap Form Yumuşak Çene Civatası

- Gümüş kaplama

Product Nr. 1486 Inner Diameter Soft Jaw Bolt

- Silver coating

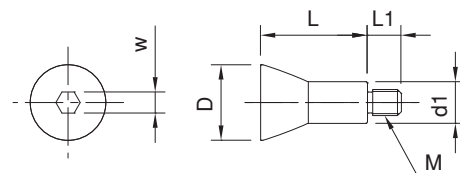

Referans Nr.	D		H	H1	R	H2		L1	Uygun Civatalar Proper Cap Screws	Sıkma Kuvveti Clamping Force Kgf	 (g)
	min.	max.				min.	max.				
1487-04001	19.5	24	9	2.5	R9.5	8	2.6	9.4	M4	200	20
1487-06001	23.5	29	13	4	R11.5	11.5	5	13	M6	500	45
1487-08001	28.5	36	17	5.5	R14	15	6	19	M8	900	90

Ürün Nr. 1487 Delik İçi Bağlama

- Sertleştirilmiş
- Siyah Kaplama

Product Nr. 1487 I.D. Holding Clamps

- Hardened
- Black coated

Özellik

- Bu pabuçlar iş parçasını iç çaptan sıkma işlemi yapar.
- Kamanın konik yapısından dolayı güçlü bir bağlama yapar.
- Uzun strok özelliği ile dökülmüş deliklerde ve kaba deliklerde kullanım olanağı sağlar.

Feature

- These clamps hold the inside diameter of the workpiece.
- The wedge construction allows powerfully clamping the workpiece.
- Long clamping stroke is ideal for holding as-cast or roughly-finished holes.

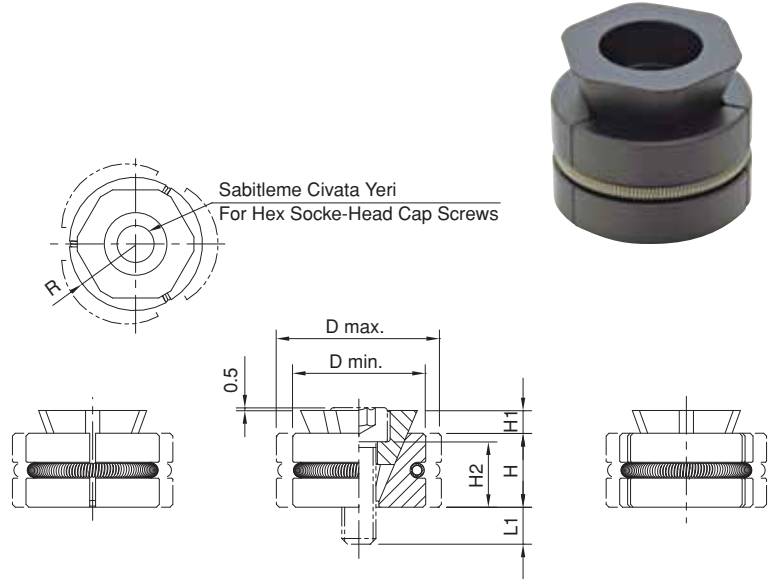

Kullanım Şekli / How To Use

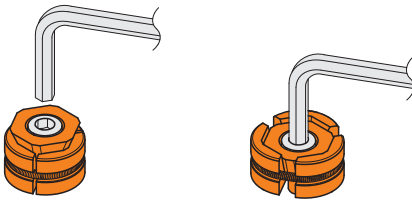

Açık Konum
Unclamping Mode

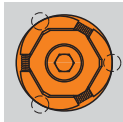

Kapalı Konum
Clamping Mode

İş parçasını sıkma anında çizgi halinde temas eder. Finit delikler için tavsiye edilmez. Delik içinde deforme olabilir.

The clamp makes a line contact with the workpiece at the clamping mode. This contact can mar the surface of the workpiece depending on its materials, and using these clamps for accurately finished holes is not recommended.

Not

- Doğru bir merkezleme işlemi aşağıdaki görsel gibidir.

Notes

- For accurate locating, use these clamps with a locator as shown below.

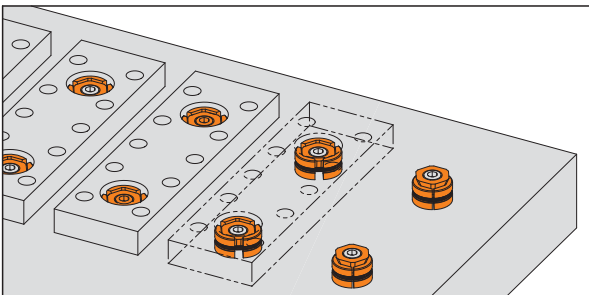
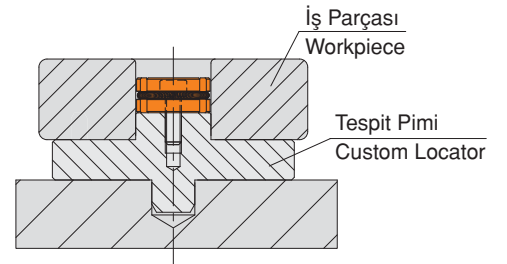

2'li bağlama uygulama örneğidir.

Example of application where two I.D. Holding Clamps are used.

Referans Nr.	d		h		h1	M	L1	W	Sıkma Kuvveti Clamping Force kgf	Tork Değeri Allowable Screw Torque (N - m)	 (g)
	min.	max.	d min.	d max.							
1487-04001A	8	10.3	5.5	4.6	0.9	M4x12	7.3	2.5	900	2.1	3
1487-05001A	10	12.3	6.4	5.6	1.1	M5x15	9.1	3.	1500	4.3	5
1487-06001A	12	16.3	8.6	7	1.3	M6x18	11.2	4.	2100	7.3	9
1487-08001A	16	22	11.5	9.4	1.6	M8x25	16.2	5	4000	18	22
1487-04001B	8	10.3	5.5	4.6	5.1	M4x12	7.1	3	1500	2.7	4
1487-05001B	10	12.3	6.4	5.6	6.2	M5x15	9	4	2500	5.4	7
1487-06001B	12	16.3	8.6	7	7.9	M6x18	10.6	5	5000	9.1	11
1487-08001B	16	22	11.5	9.4	10.4	M8x25	15.4	6	9000	25	28



Ürün Nr. 1487 Delik İçi Bağlama

- Sertleştirilmiş
- Siyah Kaplama

Product Nr. 1487 I.D. Holding Clamps

- Hardened
- Black Coated

Özellik

- Bu bağlamalar / clampers iş parçasının iç çapından tutar.
- İş parçasını Kama Konstrüksiyon güçlü sıkmasını sağlar.
- Uzun sıkma stroku döküm veya kabaca bitmiş delikleri tutmak için idealdir.

Features

- These clamps hold the inside diameter of the workpiece.
- The wedge construction allows powerfully clamping in the workpiece.
- Long clamping stroke is ideal for holding as-cast or roughly-finished holes.

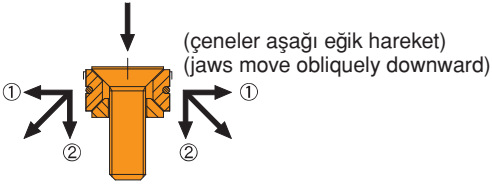

- ① İş parçasına karşı yatay basınç
Horizontal pressure against workpiece
- ② İş parçasının yükselmesini engelleyen dikey basınç.
Vertical pressure preventing workpiece lift

Kullanım Şekli / How To Use

Not

- Pabuç iş parçasını sıkma modundayken bağlantı hattına temas eder. Kendi meteryallerine bağlı iş parçası yüzeyini işaretleyebilirsiniz ama bitmiş / finish delikler için bu pabuçların kullanılması tavsiye edilmez.

Notes

- The clamp makes a line contact with the workpiece at the clamping mode. This contact can mark the surface of the workpiece depending on its materials and using these clamps for accurately finished holes is not recommended.

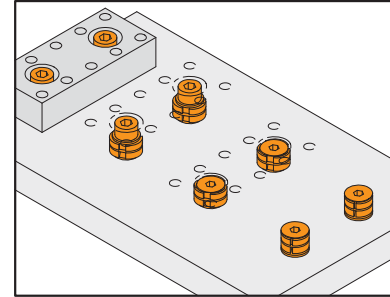
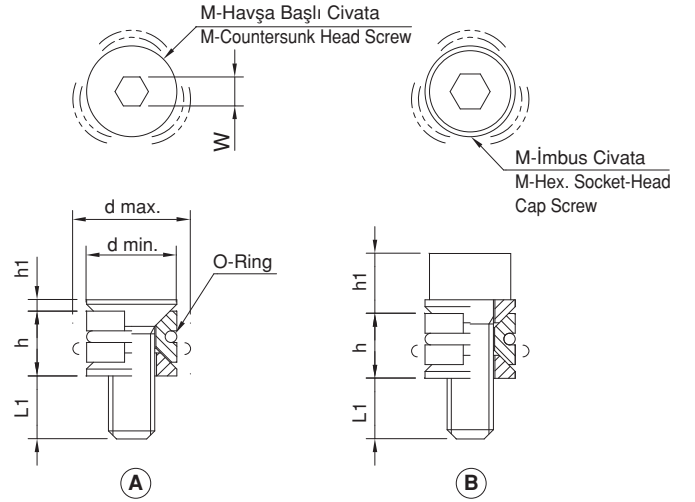
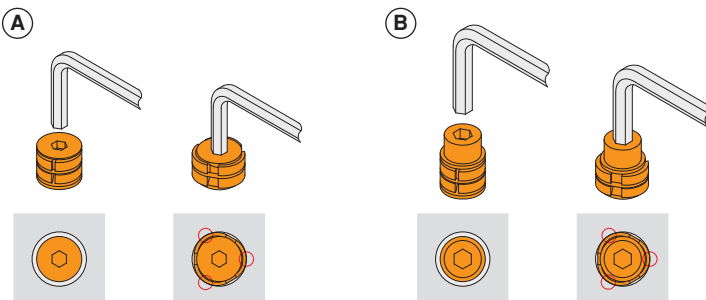

Delik içi bağlamaların kullanıldığı iki kompakt uygulamalardan örnek.

Example of applications where two compact ID holding clamps are used.

Not

- Aşağıda gösterildiği gibi doğru yer tespiti için, bir konum belirleyici ile bu pabuçları kullanın.

Notes

- For accurate locating, use these clamps with a locator as shown below.

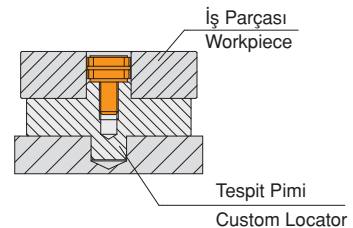

Referans Nr.	Ayarlanabilir İş parçası çapları Adaptable Workpiece Dia.	d1	d2	h2	h1	d (⁰ / _{-0.05})	h	M	L	w	M1	L1	dp	Sıkma Kuvveti Clamping Force Kgf	Tork Değeri Allowable Screw Torque (N - m)	İzin Verilen Boşluk Recommended Range of Expansion of Dia	İzin Verilen Açılma Çapı Allowable Expansion of Dia	(g)
1488-00004	Ø7.1-Ø12.4	12.4	7.1	15	16	29.72	21.8	M4	7.2	3	M3	6	21	420	5	0.07	0.13	45
1488-00006	Ø12.2-Ø14.2	14.2	12.2	15	19	31.5	24.9	M6	11.2	5	M3	6	23.1	440	17	0.08	0.23	60
1488-00008	Ø13.5-Ø20	20	13.5	15	19	37.5	24.9	M8	13.2	6	M3	6	29	1100	34	0.08	0.30	95
1488-00010	Ø18-Ø27	27	18	17.5	22.2	50	28.6	M10	16.3	8	M4	7	39.4	2000	60	0.08	0.35	190
1488-00012	Ø23-Ø35.3	35.3	23	20.6	25.4	56	31.8	M12	20.3	10	M4	7	45.5	2600	150	0.08	0.35	300
1488-0016A	Ø29.3-Ø42	42	29.3	27	31.8	69.5	39.6	M16	21.4	14	M5	13	55.9	4400	280	0.08	0.35	570
1488-0016B	Ø29.3-Ø51.5	51.5	29.3	27	31.8	75.5	39.6	M16	21.4	14	M5	13	63.9	4400	280	0.08	0.35	750
1488-0016C	Ø29.3-Ø77.7	77.7	29.3	32.3	37.6	107.5	45.5	M16	19.3	14	M6	14	92.6	4400	280	0.15-0.4	0.60	1800
1488-0016D	Ø29.3-Ø103	103	29.3	32.3	37.6	132.9	45.5	M16	19.3	14	M6	14	118.1	4400	280	0.15-0.4	0.60	2900
1488-0016E	Ø29.3-Ø175	175	29.3	32.3	37.6	132.9	45.5	M16	19.3	14	M6	14	118.1	4400	280	0.15-0.4	0.80	6500
1488-0016F	Ø29.3-Ø250.2	250.2	29.3	32.3	37.6	152.4	45.5	M16	19.3	14	M6	14	133.4	2600	170	0.15-0.4	0.80	4800

Ürün Nr. 1488 Delik İçi Bağlama

Gövde

- Siyah Kaplama

Civata

- Sertleştirilmiş

Özellik

- Delik çapından tutma işlemi yapar
- Mükemmel kullanımıyla birden fazla sıkma seçeneği sağlar
- Sağ tarafta görüldüğü gibi hidrolik çekme ile de kullanım olanağı sağlar.
- İş parçasına göre ayarlama olanağı sağlar

Not

- İşlenmiş olan parçaların köşeleri minimum 0.5 köşe olmalı. Radüs olabildiğince büyük olmalı
- İş parçasının deliği radüse denk gelirse burç kullanın
- İsteğe bağlı dış çap ölçü değişikliği yapabiliriz.

Product Nr. 1488 I.D. Holding Clamps

Body

- Black coated

Tapered Screw

- Hardened

Features

- Can hold workpieces on an inside diameter.
- Perfect for multiple-parts holding arrangement.
- Using hydraulic pull cylinders to clamp instead of using hex wrenches allows automation.
- Can be machinable to suit your workpieces.

Notes

- The minimum radius of corners at the machined part should be 0.5mm for clamping small workpieces. To prevent stress concentration on these corners, make the radius as large as possible.
- If the radius will interfere with the bottom of the workpiece bore, we suggest a ring or rest-pads be fixed to the flange.

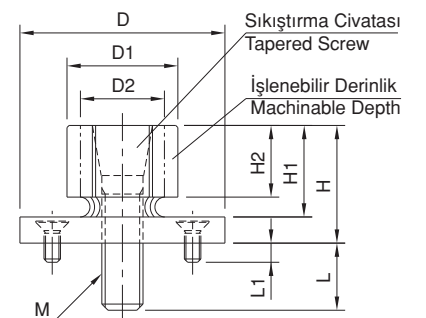
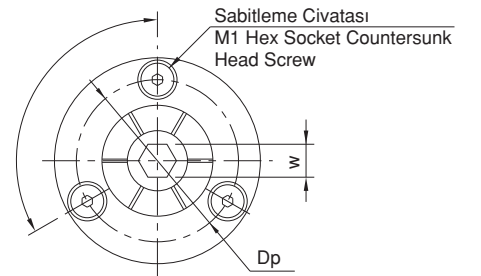
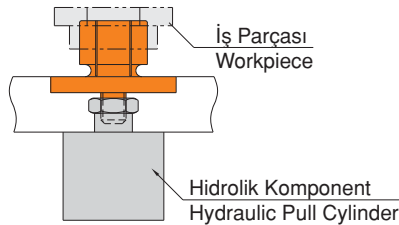
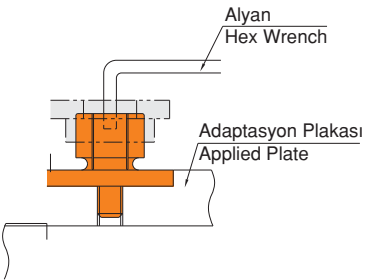

Referans Nr.	Sıkma Kuvveti Clamping Force (N)	Kaldırma Kuvveti Lifting Force (N)	(g)
1489-0840R.06	600	100	220
1489-0840R.06N	700	-	215

0840R.06

0840R.06N



Ürün Nr. 1489 Tek Dokunuş Bağlama
• Siyah Kaplama

Product Nr. 1489 Single Touch Clamp
• Black coating

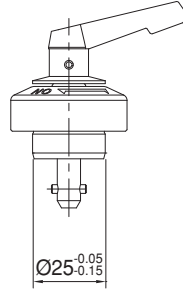
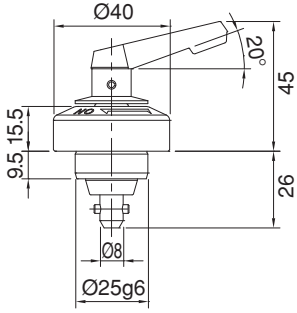
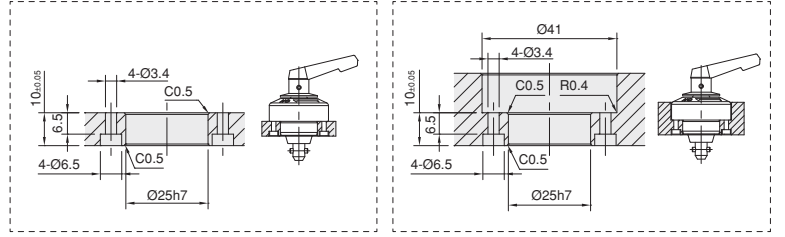
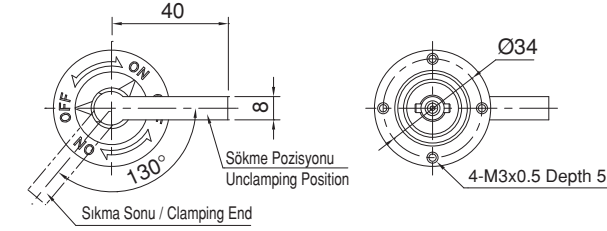

0840R.06

0840R.06N

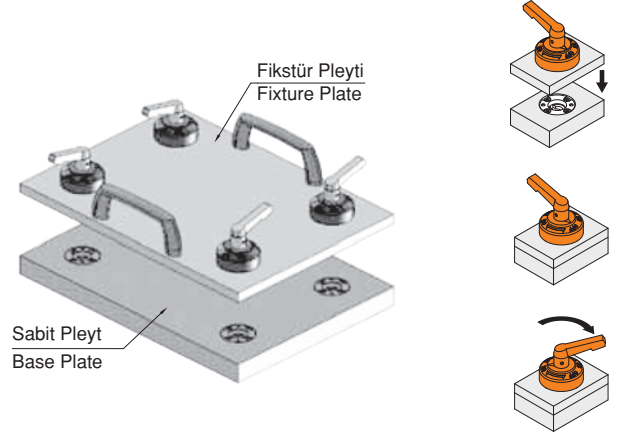

Referans Nr.	(g)
1489-0840R	32

Ürün Nr. 1489 Tek Dokunuş Bağlama Burcu
• Siyah Kaplama

Product Nr. 1489 Single Touch Clamping Bush
• Black coating

Tek Dokunuş Bağlama Burcu

Single Touch Clamping Bush

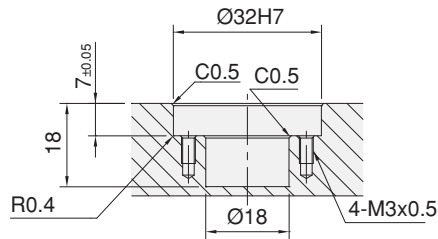
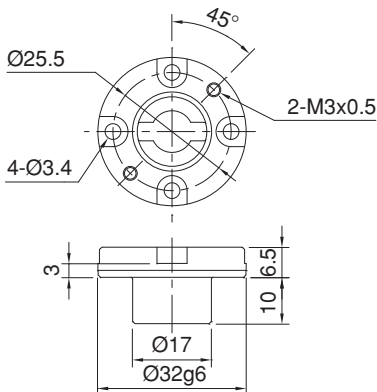

Tolerans / Tolerance ±0.02

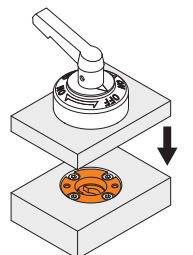
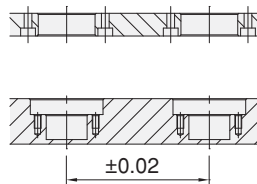

Referans Nr.	D (g6)	H	D1	H1	M	H2	M1	Dp	Kaldırma Kuvveti Lifting Force (N)	(g)
1489-16032K	32	6.5	20	7	M3	3	M3x0.5	25.5	110	60
1489-25050K	50	10	32	9	M4	5	M4x0.7	42	180	160
1489-38070K	70	15	48	14	M5	9	M5x0.8	60	400	508
1489-56095K	95	22	70	21	M6	15	M6x1.0	84	690	1451



Ürün Nr. 1489 Konumlama Burcu (Kapalı)

- Kaldırma kuvveti hareketli konik burcu yukarı itmek için yay kuvvetini kullanır.(N)
- Vidalar doğru sırayla sıkılmadığında tekrarlanabilirlik 0.01 aşabilir.
- Toplam yük, maksimum yük kapasitesini aşıyorsa, tekrarlanabilirlik 0.01 aşabilir.

Product Nr. 1489 Flex Locator Bushings (Blind)

- The lifting force is the power of the inner spring of the body to push up the movable tapered bushing.(N)
- If the screws are not tightened in the correct order, the locating repeatability may exceed 0.01
- If the total load exceeds the maximum loading capacity, the locating repeatability may exceed 0.01

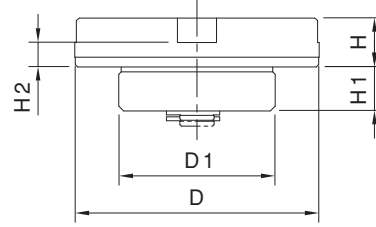
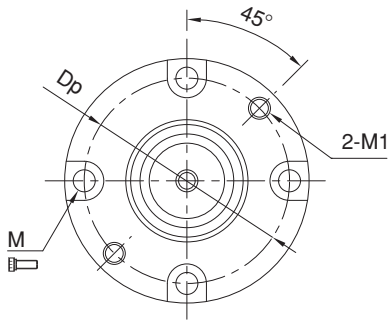

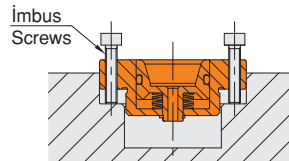
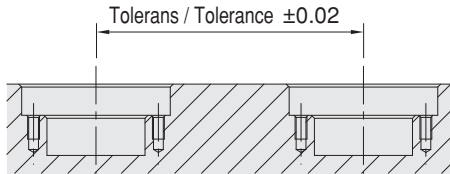
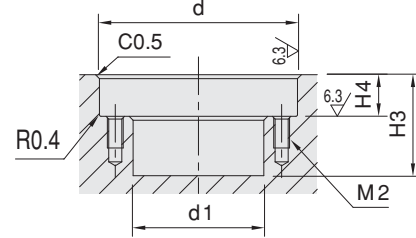

Montaj Detayı / Mounting Details

Referans Nr.	d (H7)	H4 (±0.05)	d1	H3	M
1489-16032	32	7	21	18	M3x0.5
1489-25050	50	10.5	33	24	M4x0.7
1489-38070	70	15.5	49	35	M5x0.8
1489-56095	95	22.5	71	51	M6x1.0

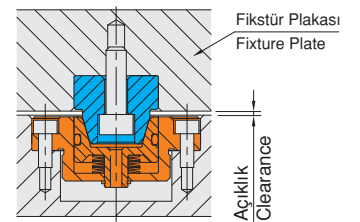
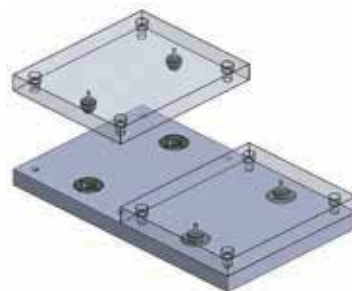
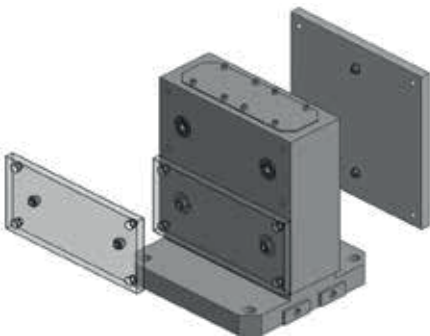

Uygulama Örneği / Application Example



Referans Nr.	D (g6)	H2	H	M	H1	d	
1489-16032	16	5.5	11.5	M5x0.80	6	8	18
1489-25050	25	10	20	M8x1.25	11.5	11	49
1489-38070	38	15	29.5	M10x1.50	18	14	176
1489-56095	56	22	43.5	M16x2.00	28.5	20	569



Ürün Nr. 1489 Konumlama Pimi

Product Nr. 1489 Flex Locator Pins

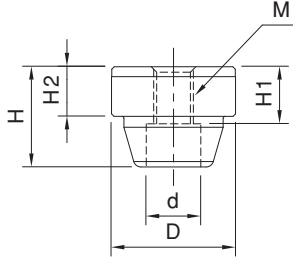

Montaj Detayı / Mounting Details

Referans Nr.	d1 (H7)	H3 (±0.05)	M1
1489-16032	16	6	M4x0.7
1489-25050	25	10.5	M6x1.00
1489-38070	38	15.5	M8x1.25
1489-56095	56	22.5	M12x1.75

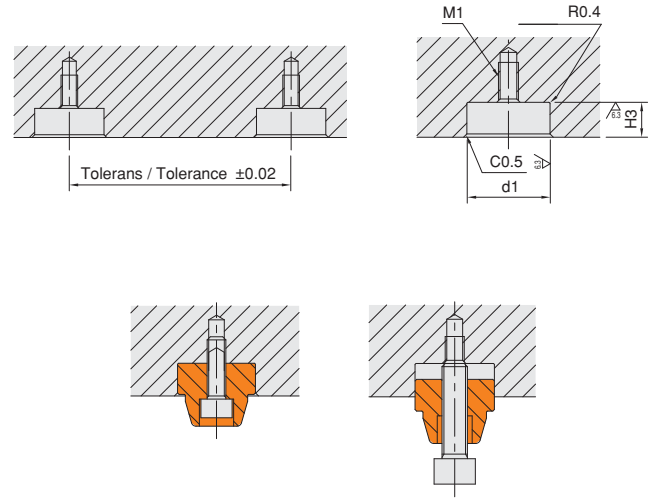

Referans Nr.	D	H	M	W	
1489-16032P	12	4	M3x0.5	2	3
1489-38070P	19	6	M4x0.7	2.5	5
1489-25050P	29	7	M5x0.8	3	14
1489-56095P	44	8	M6x1.0	4	35

Ürün Nr. 1489 Konumlama Pimi Kapağı

Product Nr. 1489 Flex Locator Protecting Covers

Konumlama Pimi Kapağı

Flex Locator Protecting Covers

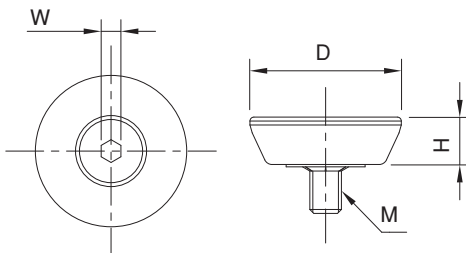

Montaj Detayı / Mounting Details

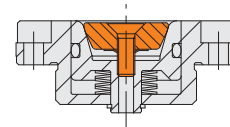



Referans Nr.	D	H	H1	M	Kaldırma Kuvveti Lifting Force (N)	(g)
1489-12025A	25 ^{+0.028} _{+0.018}	16	8	M8x1.25	540	46
1489-15032A	32 ^{+0.031} _{+0.021}	20	9	M10x1.50	600	92
1489-20045A	45 ^{+0.031} _{+0.021}	26	11	M14x1.50	780	230

Ürün Nr. 1489 Konumlama Burcu (Açık)

- Kaldırma kuvveti hareketli konik burcu yukarı itmek için yay kuvvetini kullanır.(N)
- Vidalar doğru sırayla sıkılmadığında tekrarlanabilirlik 0.01 aşabilir.
- Toplam yük, maksimum yük kapasitesini aşıyorsa, tekrarlanabilirlik 0.01 aşabilir.

Product Nr. 1489 Flex Locator Bushings (Through)

- The lifting force is the power of the inner spring of the body to push up the movable tapered bushing.(N)
- If the screws are not tightened in the correct order, the locating repeatability may exceed 0.01
- If the total load exceeds the maximum loading capacity, the locating repeatability may exceed 0.01

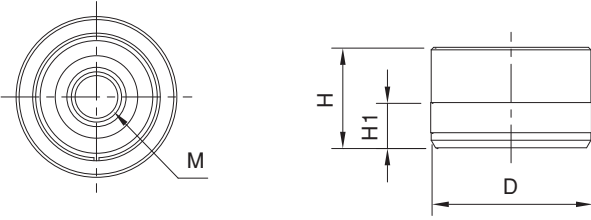

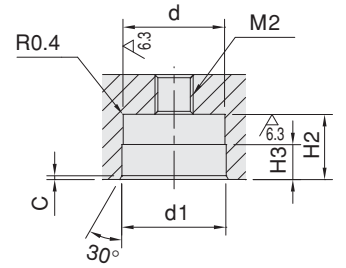
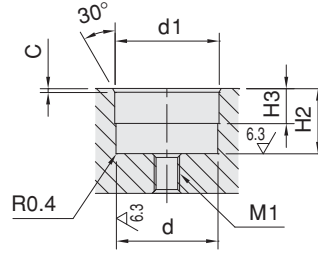
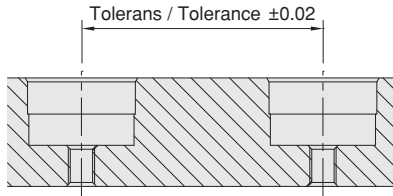
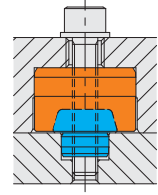
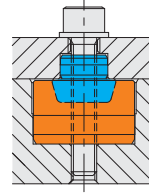

Montaj Detayı / Mounting Details

Referans Nr.	d (H6)	H2 (±0.05)	d1	H3	M1	M2
1489-12025	25	16.5	25.2	8	M6x1.00	M10x1.50
1489-15032	32	20.5	32.2	11	M8x1.25	M12x1.75
1489-20045	45	26.5	45.2	15	M12x1.75	M16x2.00

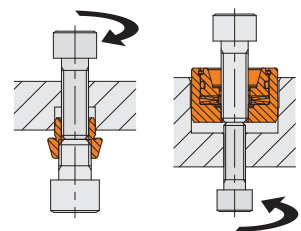
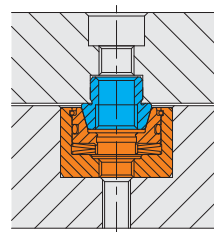
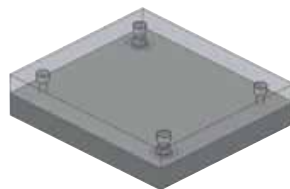
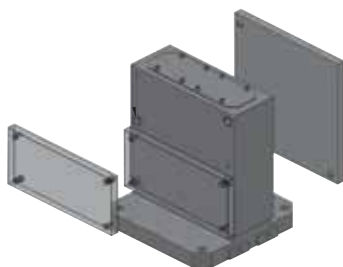

Uygulama Örneği / Application Example



Referans Nr.	D1 (p6)	H1	D	H	M	d	
1489-12025	12	4.5	15	10	M10x1.50	8.5	6
1489-15032	15	7.5	20	15	M12x1.75	10.2	16
1489-20045	20	10	30	20	M16x2.00	14	47



Ürün Nr. 1489 Konumlama Pimi

Product Nr. 1489 Flex Locator Pins

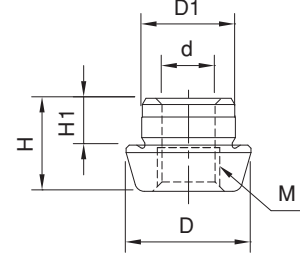

Montaj Detayı / Mounting Details

Referans Nr.	d (H6)	H2	M1	M2
1489-12025	12	5.5	M8x1.25	M6x1.00
1489-15032	15	8.5	M10x1.50	M8x1.25
1489-20045	20	11	M14x1.50	M12x1.75

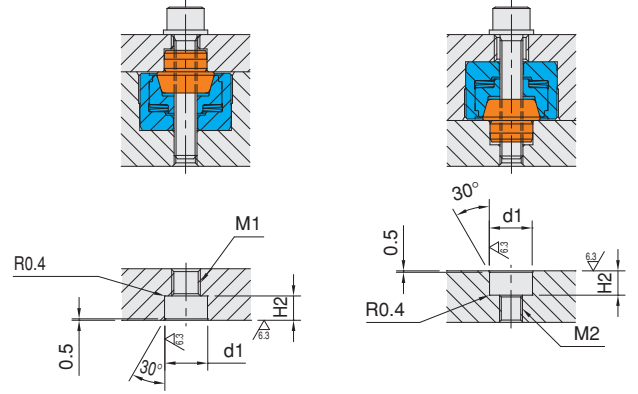
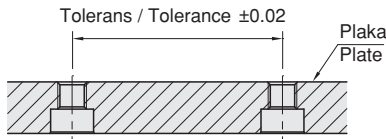

Referans Nr.	D	H	D1	M	
1489-12025P	15	10	9	M4x0.7	2
1489-15032P	19	13	11	M5x0.8	5
1489-20045P	29	18	16	M6x1.0	17

Ürün Nr. 1489 Konumlama Pimi Kapağı

Product Nr. 1489 Flex Locator Protecting Covers

Konumlama Pimi Kapağı

Flex Locator Protecting Covers

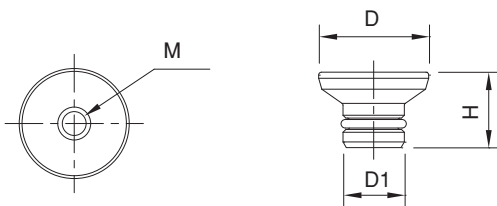

Montaj Detayı / Mounting Details

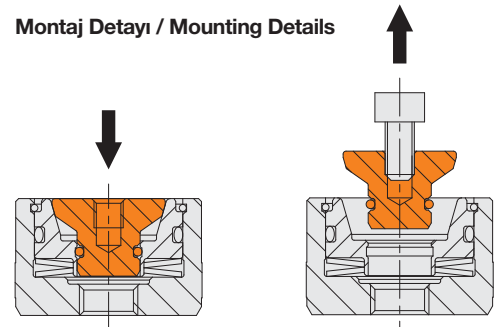

Referans Nr.	d1 g6	h3	d2	h1	D	h	d3 (h8)	h2	d	Lf	d4	dp	M	Hava Basıncı Air Pressure (MPa)	Sıkma Kuvveti Clamping Force (N)	(g)
1489-18L4S	24	8	23.4	29.5	40	8	12	11	4.5	3.5	8	32	-	0.5	250	154
1489-26L4S	32	8.5	31.4	31.7	51	9.5	16	16	5.5	4	9.5	41	-	0.5	350	289
1489-18L4SG	24	8	23.4	29.5	40	8	12	11	4.5	3.5	8	32	M4x0.7	0.5	250	136
1489-26L4SG	32	8.5	31.4	31.7	51	9.5	16	16	5.5	4	9.5	41	M5x0.8	0.5	350	252

Ürün Nr. 1489 Pnömatik Bağlama

- Nikel Kaplama
- Tekrarlama Hassasiyeti $\pm 10\mu\text{m}$

Product Nr. 1489 Pneumatic Clamp

- Nickel Coating
- Repeat Accuracy $\pm 10\mu\text{m}$

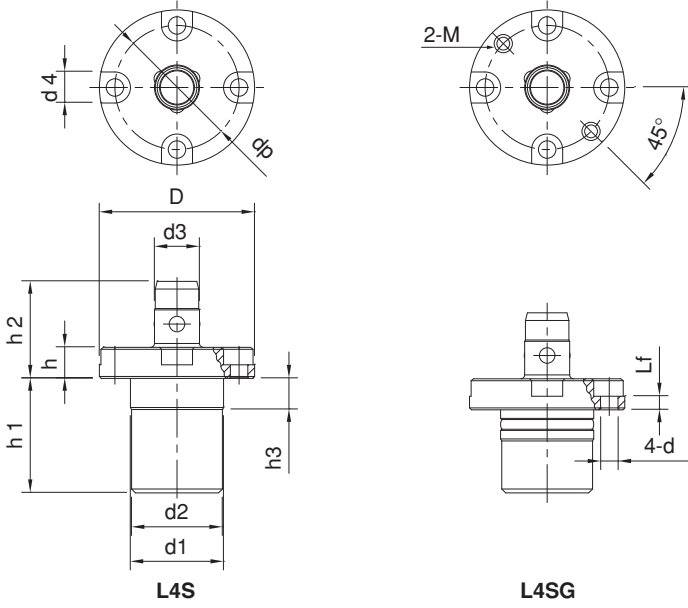

L4S

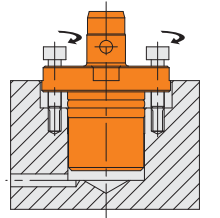
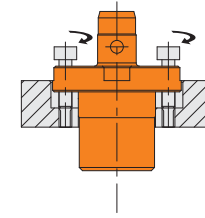

L4SG

Pnömatik Bağlama Burç

Referans Nr.	D1 g6	h2	d2	h1	D	h	d e7	d1	Lf	d3	M	dp	(g)
1489-18BU	20	7.5	19.6	10.5	36	8	12.1	4.5	3.5	8	M4x0.7	28	57
1489-26BU	25	7	24.6	11	44	9.5	16.1	5.5	4	9.5	M5x0.8	34	97

Ürün Nr. 1489 Pnömatik Bağlama Burç

- Nikel Kaplama
- Tekrarlama Hassasiyeti $\pm 10\mu\text{m}$

Product Nr. 1489 Pneumatic Clamping Bush

- Nickel Coating
- Repeat Accuracy $\pm 10\mu\text{m}$

